

Chapter C

AIR CONDITIONING

SECTION PAGE

PART 1

HEATING, DEMISTING AND VENTILATION SYSTEM

C1	Overhaul	C1
C2	Fault Diagnosis	C13

PART 2

REFRIGERATION SYSTEM

C3	Special Information and Precautions	C17
C4	Servicing	C19
C5	Compressor	C21
C6	Suction Throttling Valve and Expansion Valve	C31
C7	Evaporator, Condenser, Receiver /Drier Unit and 'Fast-Idle' Solenoid	C37
C8	Electrical Actuators and Flaps	C41
C9	Rear Refrigeration Unit	C43
C10	Fault Diagnosis	C55
C11	Workshop Tools	C57

Chapter C

PART 1

HEATING, DEMISTING AND VENTILATION SYSTEM

Section C1 OVERHAUL

Underwing ducting—To remove (see Fig. C1)

1. On early cars, the underwing ducting is fitted to both sides of the car, on late cars it is fitted to the driver's side only. In the operations that follow, the procedure is given for the removal of the ducting from both sides of the car.
2. Apply the hand brake and chock the rear wheels of the car.
3. Using the lever specially provided in the tool kit, carefully remove the embellishers from the front wheels.
4. Slacken the front wheel nuts; note that from the driver's seat, the nuts on the right-hand side of the car have right-hand threads and conversely, the nuts on the left-hand side of the car have left-hand threads.
5. Position a jack underneath the front lower triangle levers pivot points. Jack up the car so that the front wheels are clear of the ground. As a precaution against the jack failing, support the front of the car on two sets of wooden blocks placed underneath the extremities of the lower triangle levers adjacent to the ball joints.
6. Remove the wheel securing nuts and remove the front wheels.
7. Remove the caps and screws securing the undersheets to the under-side of each front wing; remove the undersheets. The caps are fitted to the threaded end of the screws which protrude through the body into the engine compartment.
8. Slacken the worm drive clips securing the large air transfer tube between the carburetter and the air silencer/cleaner.
9. Remove the two clamp bracket screws securing the tube at a point midway between the ends of the tube; remove the tube.
10. Withdraw the air silencer/cleaner intake tower from the air silencer/cleaner.
11. Remove the centre knurled screw securing the end cover and cleaner components to the air silencer/cleaner box. For further information on the air silencer/cleaner, refer to Chapter K—Section K3.
12. Remove the six setscrews securing the air silencer/cleaner, then remove the air silencer/cleaner from underneath the wing.
13. Remove the long ram air transfer tubes which are fitted beneath each front wing. Each transfer tube is secured in position by two worm drive clips and two clips with a nut and bolt fixing.
14. Remove the three setscrews securing the inlet scoop which is secured underneath each wing at the front of the car; remove the two scoops.
15. Using a wedge shaped tool, lift back the trim surrounding the ram air outlet ducts; the trim is secured in position by small tacks.
16. With the help of an assistant, support the outlet ducting situated underneath each wing then, remove the four screws securing each circular outlet duct to the side scuttle wall; remove the ducting.

Chapter C

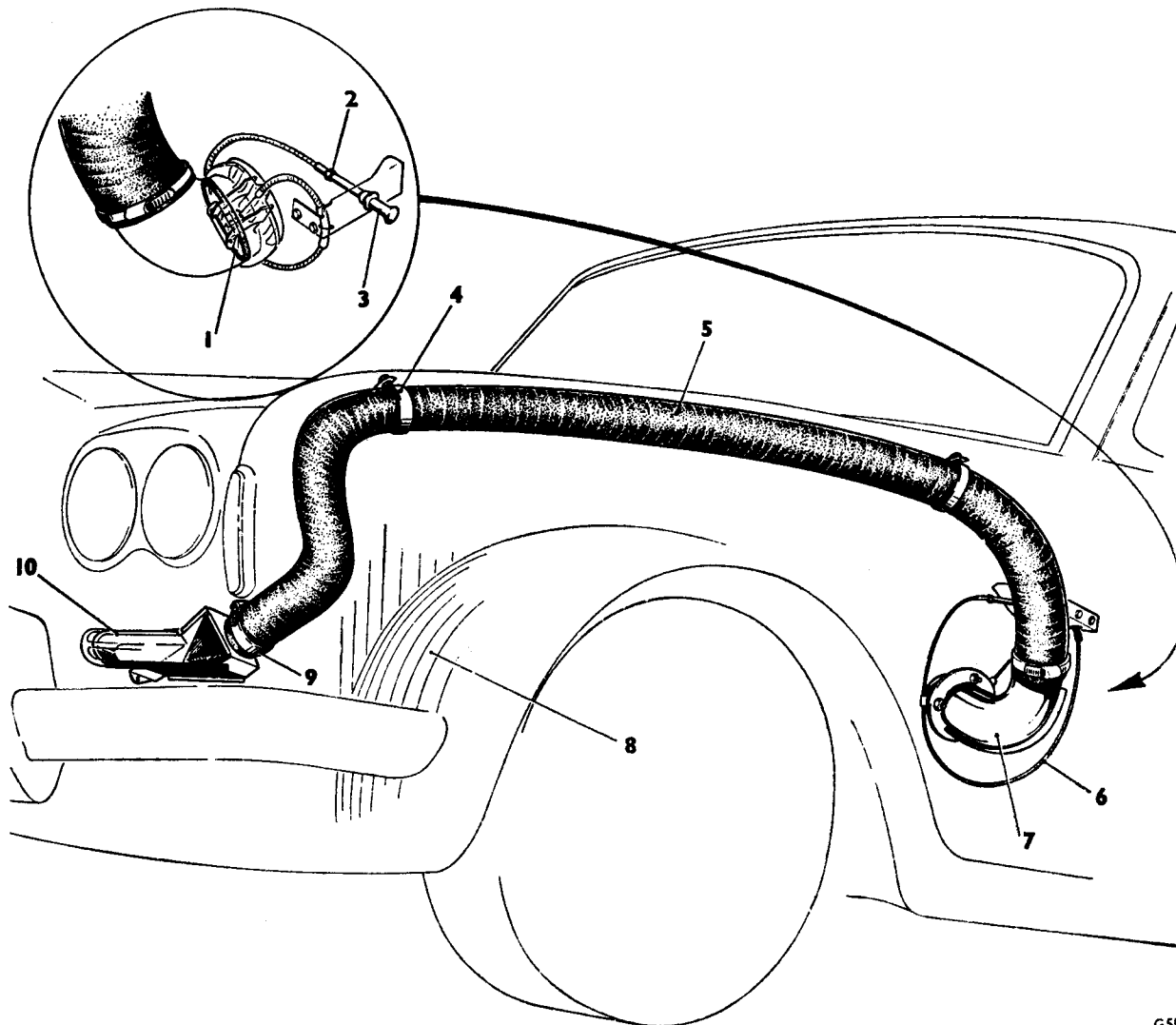

G512

FIG. C1 RAM AIR DUCTING

- | | | | | |
|-------------------------|-----------------------|------------------------|---------------------|--------------------------|
| 1 Flap valve | 3 Control knob | 5 Transfer tube | 7 Duct | 9 Worm drive clip |
| 2 Cable adjuster | 4 Clip | 6 Cable | 8 Undersheet | 10 Intake duct |

17. Remove the setscrews securing the circular outlet fixing brackets to the side scuttle then remove the brackets together with the outlet assemblies from the car.

Underwing ducting—To inspect

1. Examine the condition of the underwing ducting, particularly the long transfer tubes and the flap seal fitted to the outlet duct.

Underwing ducting—To fit

Fit the underwing ducting by reversing the procedure given for removal, noting the following point.

1. The circular outlet duct flap should be set so that it makes a perfect seal when the control knob is

pushed fully forward, i.e. the closed position; adjustment is possible by a conventional type of threaded adjuster interposed in the cable length.

Heater matrix—To remove

1. Drain the coolant from the radiator and heater matrix into a clean container as follows.

2. Remove the filler cap from the radiator header tank and open the three drain taps positioned one at the bottom of the radiator, and one at each side of the crankcase. On late cars, the crankcase drain taps are superseded by drain plugs.

3. To assist draining the heater matrix, switch on the ignition but do not start the engine, then turn clockwise either the 'UPPER' or 'LOWER' system heating switch.

4. Disconnect the battery leads.

5. Scribe the profile of the bonnet catch mounting brackets onto their adjacent cadmium plated catch parts (see Fig. C2).

6. Remove the bonnet catch springs.

7. Remove the screws securing the catch to the mounting bracket then move the catch to one side; it is not necessary to disconnect the operating cable from the bonnet catch.

8. Detach the strap securing the ducting between each blower motor and the heater box.

9. Peel back the rubber sleeve connecting the ducting to the heater box then remove the ducting.

10. Remove the three nuts and washers securing the wiper motor mounting bracket to the body, also unscrew the union nut securing the wiper drive cable into position; move the motor to one side to facilitate removal of the adjacent blower motor.

11. Disconnect the leads to each blower motor.

12. Remove the three 2 B.A. nuts securing each blower motor to its housing.

13. Remove the three nuts inside each blower motor housing and remove the housing from the bulkhead.

14. Remove the self-tapping screws securing the upper flap actuator cover plate to the heater box.

15. Release the lock-nuts then disconnect the upper flap control rods from the actuator levers. To facilitate re-assembly, retain the washers, spring and nuts with their respective control rods.

16. Disconnect the electrical connectors from each of the upper flap actuators.

17. Remove the ten nuts and washers and the four small self-tapping screws securing the heater box into position. The self-tapping screws are situated at the two outer bottom sides of the heater box and are partially hidden, but can be removed by using a long screwdriver.

18. Slacken the worm drive clips then disconnect the rubber pipes from the heater matrix. Withdraw the heater box and heater matrix from the bulkhead aperture (see Fig. C3).

19. Remove the setscrews securing the heater matrix to the heater box.

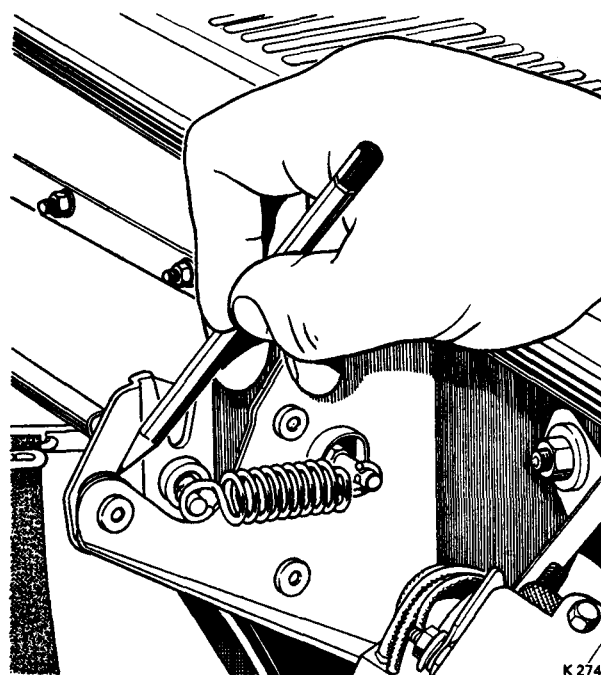

FIG. C2 SCRIBING A LINE ON THE BONNET CATCH MECHANISM TO FACILITATE ASSEMBLY

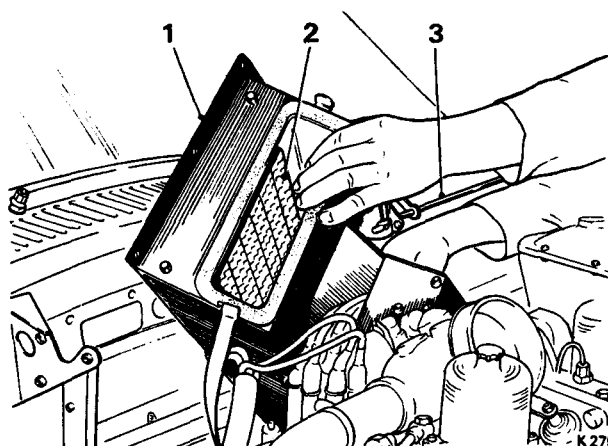

FIG. C3 REMOVING THE HEATER BOX AND MATRIX

- 1 Heater box
- 2 Heater matrix
- 3 Bonnet catch mechanism

Heater matrix—To fit

Fit the heater box by reversing the procedure described for its removal, noting the following points.

1. Check the condition of the various seals and ensure that they are fitting perfectly to their respective faces.

Chapter C

2. To renew a seal, remove the old seal and remove the old 'Bostik' from the face with 'Bostik' cleaner 6001. Allow approximately one hour for the cleaner to dry then apply a liberal amount of 'Bostik' adhesive 1261 (or its equivalent) to the surface of the new seal and its mating surface then fit the new seal into position. After approximately half-an-hour when the 'Bostik' has had time to dry, check that the seal is secure. Examine the heater matrix for signs of leakage.

3. If the heater matrix has been repaired or, if a leak under pressure is suspected, blank off the outlet connection and connect an air supply to the inlet connection. Immerse the matrix in water and test at an air pressure of 30 lb./sq. in. (2,11 kg./sq. cm.).

4. Examine the upper flap control rods to ensure that they are not bent.

5. Examine the rubber hoses for signs of deterioration and renew if necessary.

6. Care should be taken when fitting the heater box to ensure that the upper flap control rods are not bent.

7. Seal the joint between the control box and the demister duct with 2 in. (5,08 cm.) wide 'Gosheros' tape or its equivalent.

8. Set the upper temperature flap and upper quantity flap actuators as described under the appropriate headings.

Control box—To remove

1. Remove the heater box matrix (see Heater matrix—To remove).

2. Disconnect the lower temperature flap control rod at its lower connection (see Fig. C11). On late cars, remove the connecting pin.

3. Withdraw the control box through the bulkhead aperture.

Control box flaps—To set

(see Fig. C4)

1. Before attempting to set the flaps, check the condition of the seals and renew them if necessary (see Heater matrix—To fit, Operation 3).

2. Hold the flaps firmly in the positions shown in Figure C4, i.e. temperature flaps in the hot position and the upper quantity flap in the closed position.

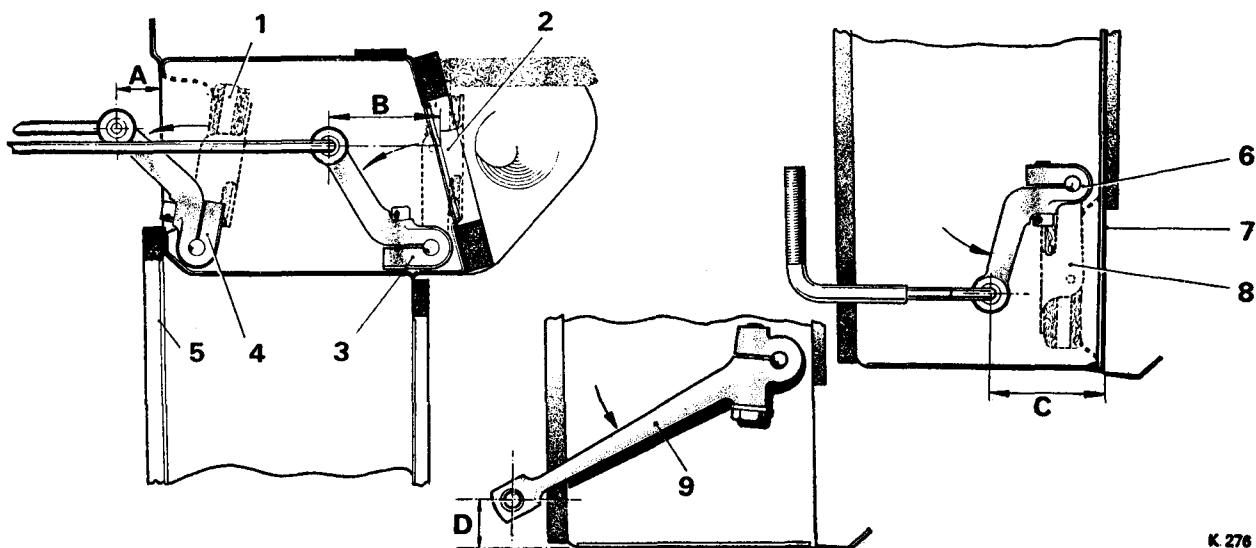

K 276

FIG. C4 CONTROL BOX SETTINGS

- | | |
|--|---|
| 1 Upper temperature flap | 5 Control box (forward face) |
| 2 Upper quantity flap | 6 Lower temperature flap lever (early type) |
| 3 Upper quantity flap lever | 7 Control box (forward face) |
| 4 Upper temperature flap lever | 8 Lower temperature flap |
| 9 Lower temperature flap lever (late type) | |

A $\frac{7}{8}$ in. (11,11 mm.)

B $\frac{1}{4}$ in. (22,22 mm.)

C $1\frac{1}{8}$ in. (3,02 cm.)

D $\frac{1}{2}$ in. (15,87 mm.)

3. Check the position of the levers to the dimensions given in the illustration and adjust if necessary.

Note The control box temperature flap lever should be set to either dimension C or dimension D depending whether the early type or late type of lever arrangement is fitted. Dimension C is early and dimension D is late.

4. Examine the joints of the control box, any holes should be sealed with 'Prestik' or other similar sealing compound.

Control box—To fit

1. Using a rubber lubricant on the seals inside the bulkhead aperture (e.g. 'Hellerine' grade M) fit the control box into the aperture, locating it on the studs.
2. Using a sealing compound such as 'Glasticon' or its equivalent, seal the lower joint between the control box and the bulkhead (see Fig. C5).

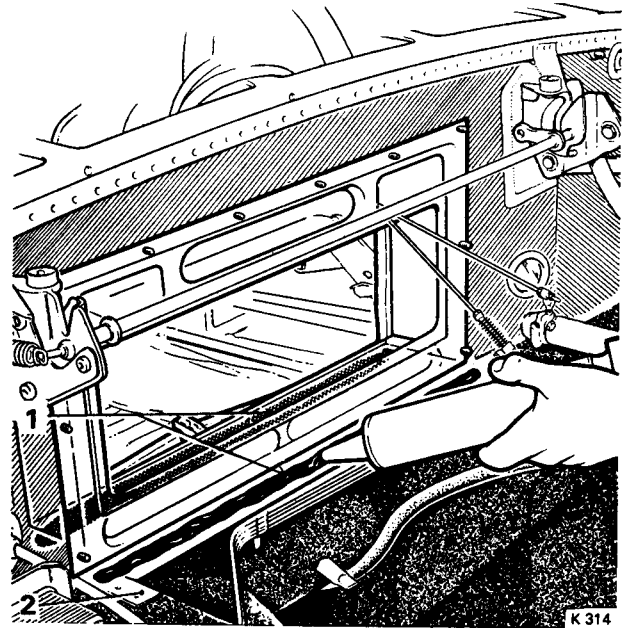

FIG. C5 CONTROL BOX FITTED INTO BULKHEAD APERTURE

- 1 Sealing compound
- 2 Rubber sealing strips

Upper flap actuators—To remove

1. Disconnect the battery.
2. Disconnect the electrical leads from the actuator terminals.
3. Remove the self-tapping screws securing the upper flap actuators cover plate to the heater box.
4. Release the lock-nuts then disconnect the upper flap control rods from the actuator levers. To facilitate re-assembly, retain the washers, spring and nuts with their respective control rods.
5. Unscrew (approximately three turns) the screws securing each actuator to the heater box, then push the special nylon inserts out of the locations in the heater box and remove the actuators; retain the two felt washers.

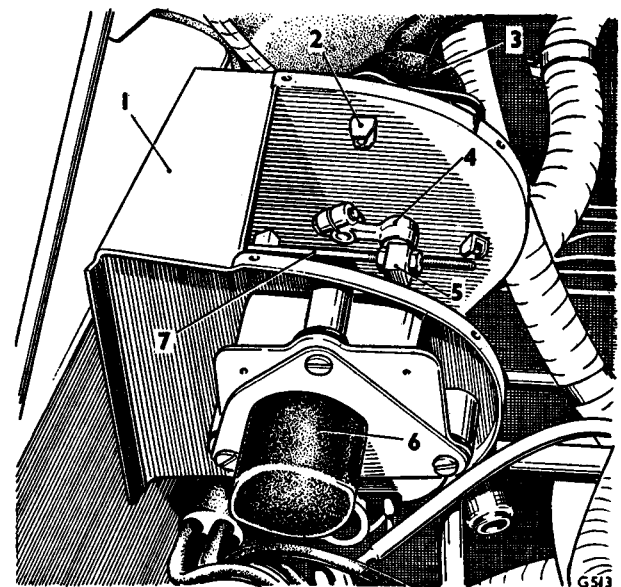

FIG. C6 UPPER QUANTITY FLAP ACTUATOR SETTING

- 1 Heater box
- 2 Nylon insert
- 3 Quantity flap actuator
- 4 Lever
- 5 Swivel pin
- 6 Temperature flap actuator
- 7 Control rod

Upper flap actuators—To fit

Fit the upper flap actuators by reversing the procedure described for their removal bearing in mind that they should be set as follows.

Chapter C

Upper quantity flap—To set

(see Fig. C6)

1. Secure the actuator to the heater box and connect the electrical wiring.
2. Switch on the ignition and select the closed position on the upper quantity flap control knob. Allow the spindle to rotate to the closed position.
3. Fit and tighten the actuator lever onto the spindle in the position shown in Figure C6.
4. Fit the control rod through the hole in the swivel pin.
5. Pull the control rod forward so that the quantity flap is felt to reach its seating (i.e. closed position); refer to Figure C4.
6. With the flap held firmly in its closed position, tighten the nuts at either side of the swivel pin to secure the control rod in position.
7. Select the three open positions in turn and check that the actuator lever stops at 45°, 90° and 180° from the closed position. Ensure that the sealing is adequate by switching on the blower motors with the flap in the closed position and checking for air leaks.

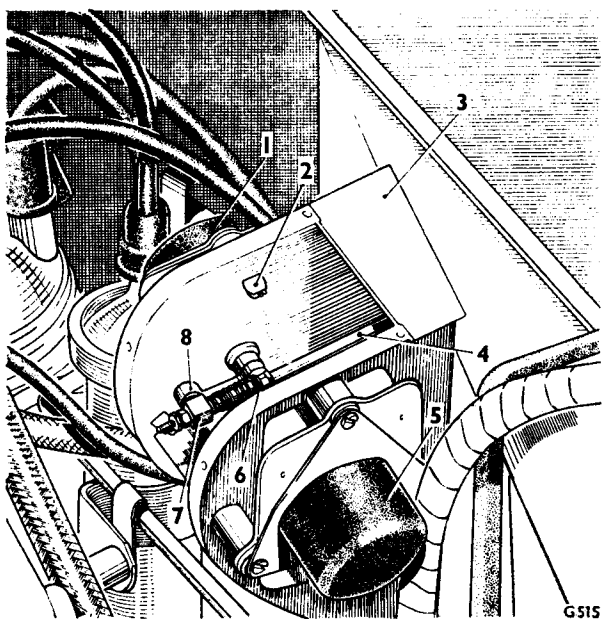

FIG. C7 UPPER TEMPERATURE FLAP ACTUATOR SETTING

- 1 Upper temperature flap actuator
- 2 Nylon insert
- 3 Heater box
- 4 Control box
- 5 Upper quantity flap
- 6 Spring
- 7 Swivel pin
- 8 Lever

8. Check that the actuator will move from the open position to closed and back to open without stalling. If the actuator stalls when approaching the closed position the flap is set too tightly and should be moved slightly toward the open position.

9. Fit the upper flap actuator cover to the heater box then fit the two clips over the lower flange of the box; secure the cover with four screws.

Upper temperature flap—To set

(see Fig. C7)

1. Secure the actuator to the heater box and connect the electrical wiring.
2. Switch on the ignition and select the hottest position on the upper temperature flap control knob. Allow the spindle to rotate to the hot position.
3. Fit and tighten the actuator lever onto the spindle in the position shown in Figure C7.
4. Fit the control rod through the hole in the swivel pin.
5. Pull the control rod forward so that the temperature flap is felt to reach its seating (i.e. hot position); refer to Figure C4.
6. With the flap held firmly in its hot position, adjust the nut adjacent to the swivel pin so that the control rod is holding the flap against its seat; tighten the lock-nut.
7. Select in turn, the four hot positions on the control knob and check that the lever stops at 45°, 90°, 135° and 180°.
8. Check that the actuator will move from the cold position to the hot without stalling. If the actuator stalls when approaching the hot position, the flap is set too tightly and should be moved slightly toward the cold position.
9. Fit the upper flap actuator cover to the heater box then fit the two clips over the lower flange of the box; secure the cover with four screws.

Lower quantity flap actuator—To remove

(see Fig. C8)

1. Switch on the ignition.
2. Push the lower quantity flap switch control to the closed position (i.e. fully in). This is done to facilitate assembly should the same actuator be refitted.
3. Disconnect the battery.
- 4(a) **Right-hand drive cars only.**
Remove the glove compartment from underneath the fascia.

The glove compartment is held into position by three screws; two inside the compartment (one head

is covered by a plastic plug), the head of the third screw is situated underneath the bottom left-hand corner of the compartment.

4(b) Left-hand drive cars only.

Unscrew the knurled screw holding the fuse box then lower the fuse box. The knurled screw is situated adjacent to the hand brake handle.

5. Disconnect the control rod from the lower flap lever 9 (see Fig. C9).

6. Remove the three setscrews securing the mounting bracket supporting the actuator.

7. Lower the mounting bracket until the electrical leads can be disconnected then disconnect the leads.

8. Lower and remove the actuator together with the control rod.

9. If the actuator requires renewal, remove the lever together with the control rod from the actuator.

Lower quantity actuator flap—To fit and set
(see Fig. C9)

1. Connect the negative lead of a 12 volt battery to the negative tag of the actuator (i.e. the tag adjacent to the number 1 tag).

2. Connect the positive lead of the battery to the number 5 tag and allow the actuator spindle to rotate to the closed position.

3. Fit and tighten the actuator lever onto the spindle in the position shown in Figure C9.

4. Fit the control rod to the lever.

5. Fit the actuator to its mounting bracket.

6. Fit the electrical leads to the actuator.

7. Fit the mounting bracket together with the actuator into position (see Fig. C8).

8. Pull downward, the flap lever 9 until the flap is felt to rest firmly on its seat i.e. closed position.

9. Adjust the length of the control rod and fit it to the flap lever; tighten the lock-nuts. The inset (see Fig. C9) shows the latest control rod.

10. Connect the battery.

11. Switch on the ignition but do not start the engine.

12. Select the three open positions in turn and check that the actuator lever stops at 45°, 90° and 180° from the closed position.

13. Fit the remaining components by reversing the procedure described for their removal.

Lower temperature flap actuator—
To remove
(see Fig. C10)

1. Turn the lower temperature flap switch to the hot position (i.e. fully clockwise). This is done to facilitate assembly should the same actuator be refitted.

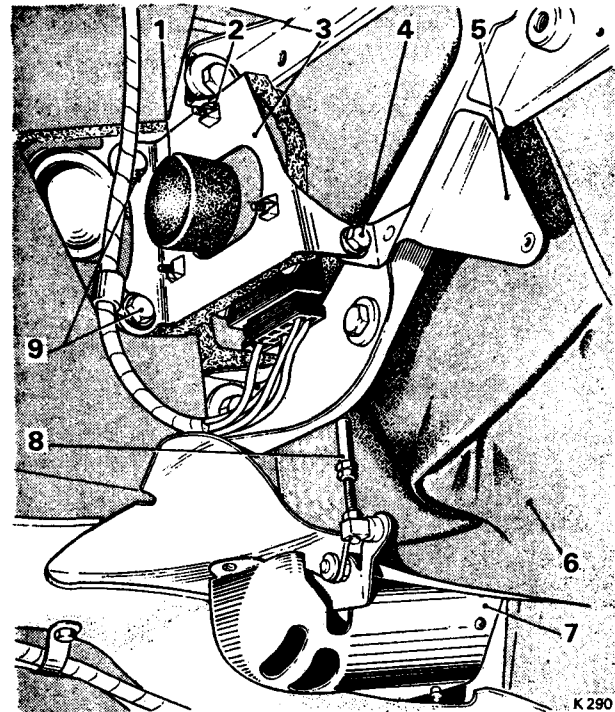

FIG. C8 POSITION OF LOWER QUANTITY FLAP ACTUATOR

- 1 Electrical actuator
- 2 Nylon insert
- 3 Actuator mounting bracket
- 4 Setscrew—Actuator mounting bracket
- 5 Instrument board mounting bracket
- 6 Evaporator box
- 7 Air deflector—Lower system
- 8 Control rod
- 9 Setscrews—Actuator mounting bracket

2. Disconnect the battery.

3. Disconnect the upper control rod from its lower control rod 8 or lever 1 (whichever is fitted); refer to Figure C11.

4(a) Right-hand drive cars.

Unscrew the knurled screw securing the fuse box into position; the knurled screw is situated adjacent to the hand brake handle.

4(b) Left-hand drive cars.

Remove the glove compartment from underneath the fascia.

The glove compartment is held into position by three screws; two inside the compartment (one head is covered by a plastic plug) the head of the third screw is situated underneath the bottom left-hand corner of the compartment.

5. Remove the three setscrews securing the actuator mounting bracket into position.

6. Lower the mounting bracket until the electrical leads can be disconnected then disconnect the leads.

Chapter C

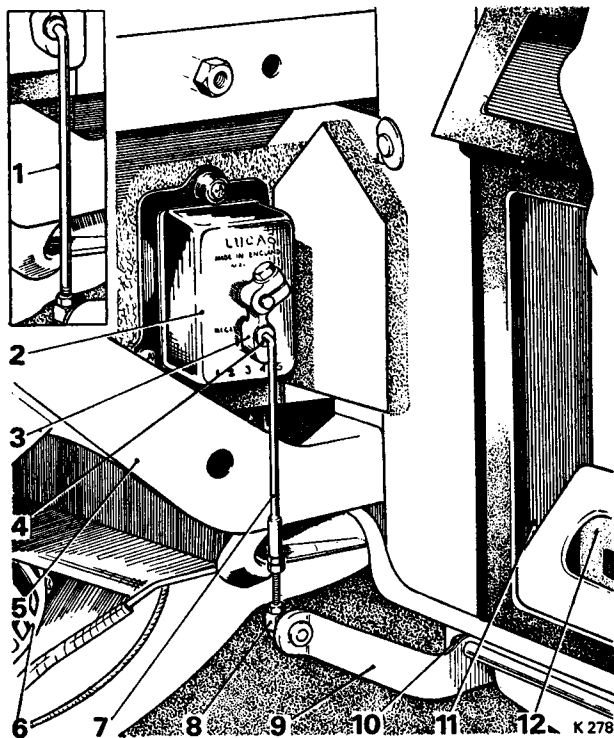

FIG. C9 LOWER QUANTITY FLAP ACTUATOR SETTING

- 1 Control rod (late type)
- 2 Electrical actuator
- 3 Lever
- 4 Bush
- 5 Instrument board mounting bracket
- 6 Outlet duct—Ram air
- 7 Control rod
- 8 Swivel pin
- 9 Lever—Lower quantity flap
- 10 Bush
- 11 Control box
- 12 Lower temperature flap

7. Lower and remove the actuator together with the control rod.

8. If the actuator requires renewal, remove the lever together with the control rod from the actuator.

**Lower temperature flap actuator—
To fit and set
(see Fig. C11)**

1. Connect the negative lead of a 12 volt battery to the negative tag of the actuator (i.e. the tag adjacent to number 1 tag).
2. Connect the positive lead of the battery to the number 5 tag and allow the actuator spindle to rotate; this will give the hot position.

3. Fit and tighten the actuator onto the spindle noting that the inset (see Fig. C12) shows the linkage arrangement for late cars.

4. Fit the control rod to the lever.

5. Fit the actuator to its mounting bracket.

6. Fit the electrical leads to the actuator.

7. Fit the mounting bracket together with the actuator into position (see Fig. C10).

8. Push the lower control rod or lever (whichever is fitted) downward until the flap can be felt to be seating firmly.

9. Adjust the length of the control rod, then with the flap held firmly on its seat, fit the lower control rod 8 or lever 1 to the upper control rod ; tighten the lock-nuts.

10. Connect the battery.

11. Switch on the ignition.

12. Select in turn the four hot positions on the control knob and check that the lever stops at 45°, 90°, 135° and 180°.

13. Check that the actuator will move from the cold position to the hot position without stalling. If the actuator stalls when approaching the hot position, the flap is set too tightly and should be moved slightly toward the cold position.

14. Switch off the ignition.

15. Fit the remaining components by reversing the procedure described for their removal.

**Lower quantity flap—To remove
(see Fig. C12)**

1. Operate the control switch to move the flap to the open position, i.e. maximum air.

2. Remove the small screws securing the two deflectors; the deflectors are situated at each end of the quantity flap. Remove the deflectors.

3. Remove the special spring which is fitted to the right-hand end of the flap (as viewed from the driver's seat).

4. Remove the two retaining washers which are fitted to each pin located at either end of the quantity flap.

5. Withdraw the flap from the bulkhead, noting that it is more convenient to remove it from the side adjacent to the front passenger seat.

Lower quantity flap—To fit

Fit the flap by reversing the procedure described for its removal noting the following point.

1. If the original seal is in poor condition, it should be removed and a new one fitted in its place (see Heater matrix—To fit—Operation 2).

Coolant tap and actuator—To remove*(see Fig. C13)*

1. Disconnect the battery.
2. Disconnect the 'Lucar' connector from the coolant tap actuator.
3. Remove the heater matrix and cylinder head hoses from the coolant tap by slackening the worm drive clips.
4. Remove the small grub screw securing the operating rod to the coolant tap lever; push the lever toward the open position (i.e. towards the engine) then withdraw the rod.
5. Slacken the pinch bolt securing the lever to the coolant tap actuator spindle; remove the lever.
6. Remove the three screws securing the coolant tap actuator to the mounting bracket; remove the actuator together with the felt washer.
7. Remove the two small nuts and bolts securing the tap to its mounting bracket; remove the tap.

Coolant tap and actuator—To fit and set

Fit the coolant tap and actuator by reversing the procedure described for its removal then set them as follows.

1. Fit the actuator to its mounting bracket.
2. Connect the electrical leads to the actuator.
3. Switch on the ignition.
4. Turn the upper and lower temperature control knobs to the closed position to allow the coolant tap actuator spindle to rotate to its closed position.
5. Fit the actuator lever onto the spindle in the position shown in Figure C13; tighten the lever onto the spindle.
6. Move the tap lever to the closed position simultaneously fitting the operating rod to the lever; the closed position is shown in Figure C13.
7. Turn the temperature control knobs to the open and closed positions and check that the coolant tap responds accordingly.

Fresh air duct flaps—To remove*(see Fig. C14)*

1. Remove the glove compartment from underneath the fascia.

The glove compartment is held in position by three screws; two inside the compartment (one head is covered by a plastic plug) the head of the third screw is situated underneath the bottom left-hand corner of the compartment.

2. Remove the trim pad surrounding the hand brake handle.

Cars prior to car number SRX 6001.

3. Remove the trim panel surrounding the radio (see Chapter M) and the two under fascia trim pads adjacent to the radio.

Cars after and including car number SRX 6001.

4. Remove the two side trim pads from the centre console and the two under fascia trim pads adjacent to the console.

All cars.

5. Remove the trim pad surrounding the steering column.
6. Remove the grub screw from each fresh air duct control knob and remove the knob; note that this grub screw is spring-loaded.

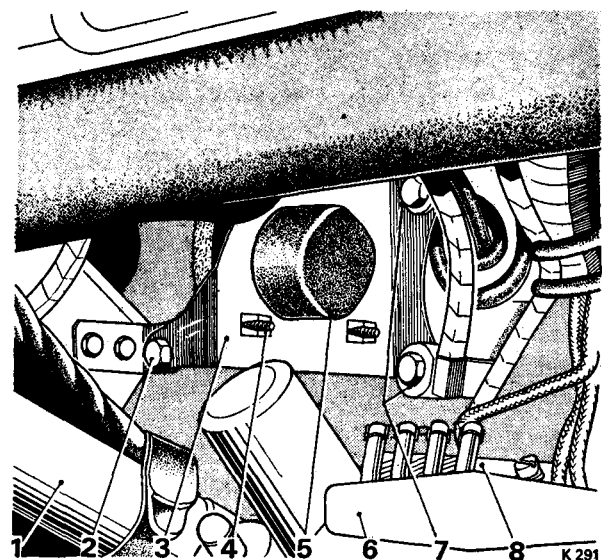

FIG. C10 POSITION OF LOWER TEMPERATURE FLAP ACTUATOR

- 1 Steering column
- 2 Setscrew—Actuator mounting bracket
- 3 Actuator mounting bracket
- 4 Nylon insert
- 5 Actuator
- 6 Handbrake handle
- 7 Setscrews—Actuator mounting bracket
- 8 Fusebox

Chapter C

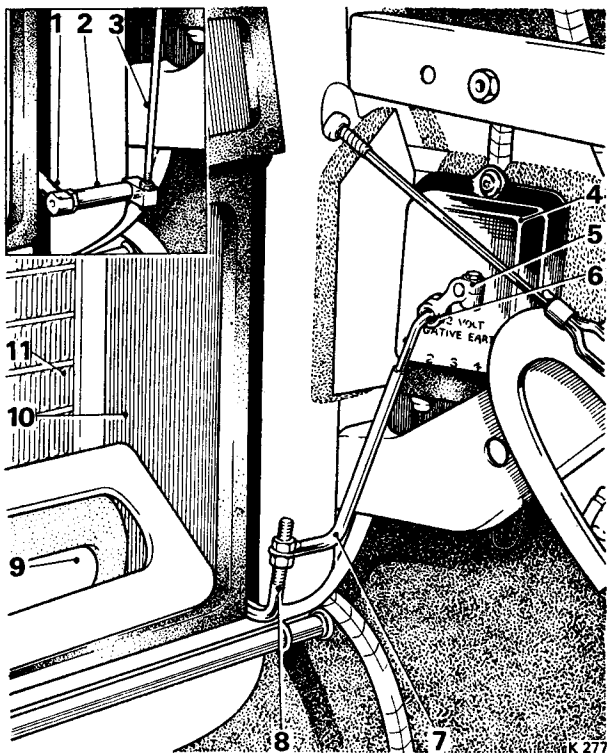

FIG. C11 LOWER TEMPERATURE FLAP ACTUATOR SETTING

- | | |
|---------------|--------------------------|
| 1 Lever | 7 Upper control rod |
| 2 Extension | 8 Lower control rod |
| 3 Control rod | 9 Lower temperature flap |
| 4 Actuator | 10 Control box |
| 5 Lever | 11 Heater matrix |
| 6 Bush | |

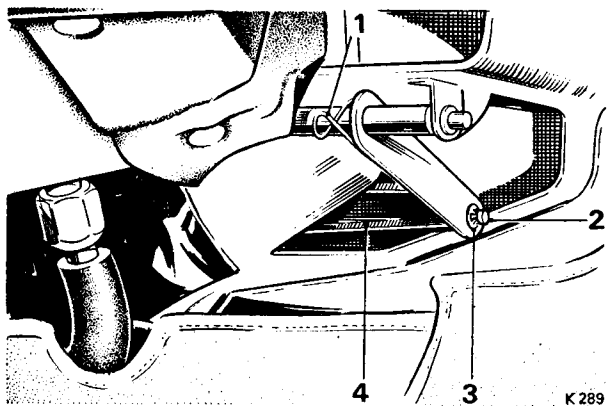

FIG. C12 POSITION OF LOWER QUANTITY FLAPS (Deflector removed)

- | | |
|----------|--------------------|
| 1 Spring | 3 Retaining washer |
| 2 Pin | 4 Flap |

7. Remove the chrome headed screws and two setscrews securing the fascia to the instrument panel; the heads of the setscrews are situated inside the fascia compartment.

8. Remove the screws securing the top roll to the instrument panel. The screws are situated underneath the protruding edge of the top roll also at each end of the top roll.

9. The remaining Operations describe the method of removing the left-hand (as viewed from the driver's seat) fresh air flap; the method for removing the right-hand flap is basically the same.

Cars after and including car serial number 6001.

10. Remove the 3 spring loaded screws securing the chrome plated deflectors to the instrument panel; remove the deflectors.

11. Move the operating mechanism so that the flap is in the fully open position.

12. Carefully remove the retaining washer from the swivel pin; remove the pin together with the two flat washers (see Fig. C14).

13. Slacken the two small grub screws securing the flap to the operating spindle.

14. Place an inspection lamp underneath the instrument panel so that the lower end of the operating spindle can be seen.

15. Carefully remove the retaining ring from the lower end of the spindle.

16. Using a long thin bar, locate the end of the spindle and push the spindle upward until it is felt to clear the holes in the two flap bosses. An assistant will be required at this stage to withdraw the spindle from the duct and through the space between the instrument panel and the windscreen. Remove the flap.

Cars prior to car number SRX 6001.

17. The procedure for removing the flap on these cars is basically the same as described in Operations 10 to 16 inclusive. One difference is that the operating linkage is attached to the lower end of the spindle instead of the top end. This necessitates removal of the spindle from below the instrument panel instead of from above.

One other difference is that the two flat washers mentioned in Operation 12 are not fitted.

Fresh air flap—To fit

Fit the fresh air flap by reversing the procedure described for its removal noting the following points.

1. Fit new retaining washers.
2. When fitting a retaining washer to the lower spindle connection, a long thin tube will be required.
3. Ensure that the retaining washers locate in their groove.
4. Ensure that when the flap is in the open position, the grub screws in the two bosses are toward the radio.
5. Adjust the 3 spring loaded screws so that equal tension is applied to the chrome deflectors and the deflectors swivel smoothly.
6. Adjust the control linkage so that when the control knob is fully withdrawn, the flap is in the open position.
7. Check that the flaps are sealing satisfactorily when the blower motors are switched on and the other flaps are in their closed position.

**Heating and demisting switches—
To remove and fit**

1. Refer to Chapter M.

Blower motor switch—To remove and fit

1. Refer to Chapter M.

Air intake filter—To remove

1. The air intake filter is situated just forward of the car windscreen, to remove the foam filter proceed as follows.
2. Remove the five setscrews securing the grille to the car body.
3. Lift the grille clear of the car body so that the windscreen washer tube can be detached from its jet connection; remove the grille together with the filter.
4. Remove the filter from the grille and remove any surplus 'Bostik' using 'Bostik' cleaner 6001.

Air intake filter—To fit

Fit the filter by reversing the procedure described for its removal noting the following point.

1. The new foam filter should be stuck to the intake grille using 'Bostik 1261'.

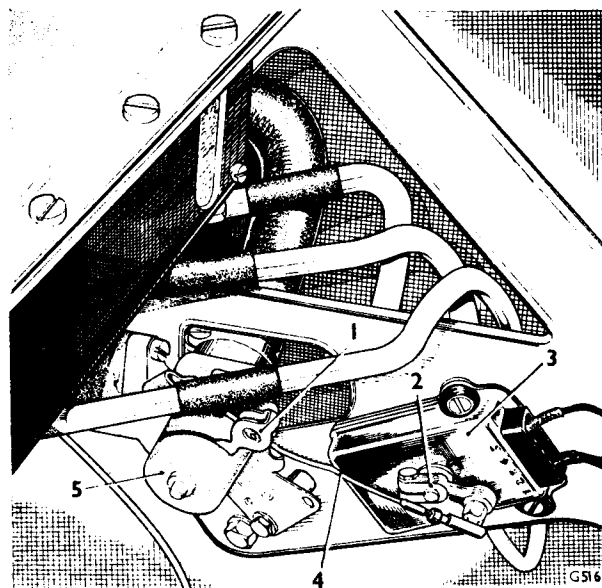
**FIG. C13 COOLANT TAP ACTUATOR SETTING**

- 1 Lever (closed position)
- 2 Lever
- 3 Actuator
- 4 Operating rod
- 5 Water tap

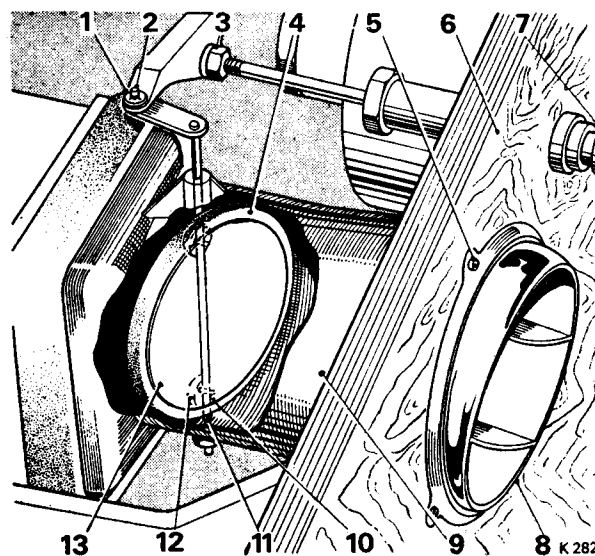
**FIG. C14 VIEW OF FRESH AIR OUTLET DUCT**

- | | |
|---------------------------------|----------------------|
| 1 Retaining washer | 7 Control knob |
| 2 Swivel pin | 8 Deflector |
| 3 Control linkage adjusting nut | 9 Duct |
| 4 Seal | 10 Grub screw |
| 5 Spring-loaded screw | 11 Operating spindle |
| 6 Instrument panel | 12 Boss |
| | 13 Flap |

Section C2

FAULT DIAGNOSIS

SYMPTOM	POSSIBLE CAUSE	ACTION
1. Ambient air only (all switch positions on both upper and lower systems)	1. (a) Faulty coolant tap (b) Faulty coolant tap relay (c) Faulty coolant tap actuator (d) Break in circuit (e) Obstruction in heater matrix (f) Temperature flaps remaining in cold position	1. (a) Fit new coolant tap (see Section C1) (b) Fit new relay (see Chapter M) (c) Fit new coolant tap actuator (see Section C1) (d) Check for circuit continuity including earth connections (see wiring diagram in Chapter M) (e) Flush matrix to clear blockage or fit new matrix (see Section C1) (f) Dismantle flaps and linkage, lubricate and reset and check actuator for correct operation (see Section C1)
2. Ambient air only, upper system	2. (a) Faulty switch (b) Break in upper system circuit (c) Temperature flap remains in cold position (d) Faulty temperature flap actuator	2. (a) Fit new switch (see Chapter M) (b) Check circuit for continuity including earth connections (see wiring diagram in Chapter M) (c) Dismantle flap and linkage, lubricate and reset (see Section C1) (d) Fit new temperature flap actuator (see Section C1)
3. Ambient air only, lower system	3. (a) Faulty switch (b) Break in lower system circuit (c) Temperature flap remains in cold position (d) Faulty temperature flap actuator	3. (a) Fit new switch (see Chapter M) (b) Check for circuit continuity including earth connections (see wiring diagram in Chapter M) (c) Dismantle flap and linkage, lubricate and reset (see Section C1) (d) Fit new temperature flap actuator (see Section C1)
4. Constant temperature at different switch positions, upper and lower systems	4. (a) Faulty switch (b) Faulty upper temperature actuator (c) Break in wiring circuit (d) Seized or loose temperature flap linkage (e) Faulty coolant tap actuator (f) Faulty lower temperature flap actuator	4. (a) Fit new switch (see Chapter M) (b) Fit new actuator (see Section C1) (c) Check for circuit continuity including earth connections (see wiring diagram in Chapter M) (d) Dismantle, clean and adjust linkage (see Section C1) (e) Fit new coolant tap actuator (see Section C1) (f) Fit new lower quantity flap actuator (see Section C1)

Printed in England

INTRODUCTION

Part 2 of this Chapter has been written to provide the refrigeration engineer with the necessary information to enable the Rolls-Royce Refrigeration System to be maintained and serviced in the correct manner.

December 1968

T.S.D. 2476

PART 2 REFRIGERATION SYSTEM

Section C3 SPECIAL INFORMATION AND PRECAUTIONS

Printed in England

December 1968

T.S.D. 2476

Exposure to refrigerant

Large quantities of refrigerant gas discharged into a confined space will displace air and could cause suffocation.

Liquid refrigerant which may accidentally escape is at least 12°F. (-11°C.) and if allowed to come into contact with the skin can cause a burn by the rapid transference of heat from the skin to the liquid as it

evaporates. Serious damage to the eyes will result from contact with liquid refrigerant. For this reason, goggles should always be worn when contact might be possible.

Should liquid refrigerant come into contact with the eye, immediate first-aid treatment is necessary and a doctor or eye specialist should be consulted as soon as possible.

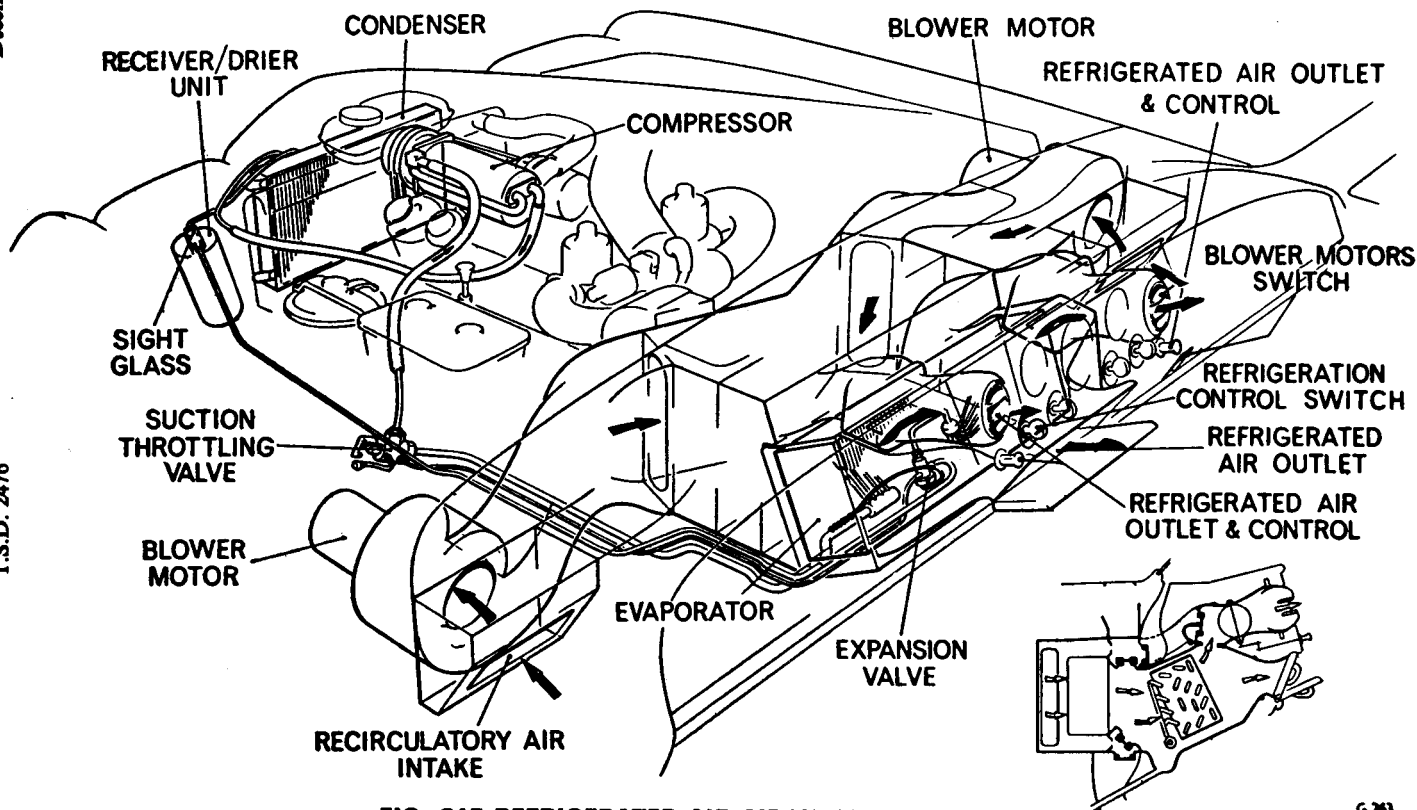

FIG. C15 REFRIGERATED AIR CIRCULATION DIAGRAM

G 243

Chapter C

First aid treatment

Medicated liquid paraffin from the first-aid kit should be applied to the eye from an eye dropper to wash away the refrigerant. The eye should not be rubbed, as this will increase the area of the injury. If, however, the eye remains painful after a few minutes, the wash should be repeated, using a sterile salt solution containing not more than 2% sodium chloride.

Importance of chemical stability

The efficient operation of the system is dependent upon the pressure-saturation temperature relationship of the refrigerant. As long as the system contains only pure refrigerant (plus a certain amount of compressor lubricant which mixes with the refrigerant), it is considered to be chemically stable.

When foreign materials such as dirt, air or moisture are allowed to enter the system, the chemical stability will be affected resulting in a change in the pressure-saturation temperature relationship of the refrigerant. Thus, the system will no longer operate at the correct

pressures and temperatures, with a consequent decrease in efficiency.

Accident damage

It is very important that the refrigeration system should be inspected as soon as possible whenever a car has been involved in an accident. If the refrigeration system has been opened as a result of the accident, dirt, air and moisture will enter the system and cause internal damage. As the length of time the refrigeration system has been open and the extent of the damage to the components will govern the replacement of parts, a definite procedure cannot be recommended which will cover all cases.

Refrigeration components—To seal

Whenever it becomes necessary to open the refrigeration system to the atmosphere all open connections must be immediately capped. Air entering the system will carry moisture, which collects quickly on the exposed surface, causing deterioration, owing to the acidic properties of a moisture/refrigerant solution.

Section C4 SERVICING

Refrigeration system—To discharge

1. The refrigerant must be discharged from the system prior to breaking any joint.
2. Refrigerant discharged in the presence of an open flame will not burn, but decompose to form a poisonous gas.
3. Remove the protective cap from the suction throttling valve (see Fig. C16). Secure a length of pipe to the 'Schrader' valve adaptor (RH 7937) in such a manner that the free end of the pipe clears the car and rests at a level below the suction throttling valve. Place a clean container under the end of the pipe.
4. Tighten the adaptor to depress the valve core until a hissing sound is heard, indicating that the refrigeration gas is escaping to atmosphere.
5. When all the refrigerant gas appears to have escaped to atmosphere, slacken the adaptor to close the valve and allow approximately 2 minutes for any build-up of pressure in the system to develop, then repeat the discharge procedure. This operation should be repeated until there is no sign of refrigerant gas being issued through the adaptor after the 2 minute build-up period.
6. Care must be taken not to release the refrigerant too quickly as this will result in oil being drawn from the system. If any trace of oil is detected loosen the adaptor. The operation should require at least fifteen minutes to ensure complete discharge.

Note Any oil which is discharged into the container should be measured and a corresponding amount added to the system.

Refrigeration system—To evacuate

1. Fit the 'Schrader' valve adaptor to the vacuum pump connection.
2. Remove the protective cap from the suction throttling valve extension.
3. Fit the 'Schrader' valve adaptor together with the vacuum pump connection to the suction throttling valve extension.
4. Switch on the vacuum pump and observe the vacuum gauge. When a reading of 28 in. Hg. is reached or when the maximum possible vacuum that can be obtained from the prevalent barometric conditions is reached, allow the vacuum pump to continue drawing a vacuum for a further 15 minutes.
5. Switch off the vacuum pump. If the system loses vacuum quickly, a leak is prevalent. If the system loses vacuum extremely slowly a leak is possible.
6. In these conditions, it is advisable to further evacuate for 45 minutes to eliminate the possibility of residual liquid 'Freon' in the compressor oil vapourising and creating a pressure rise in the system. The final vacuum reading obtained should be held for 30 minutes to ascertain that leaks are not present.

Refrigeration system—To sweep

1. Evacuate the system and charge with 1 lb. (0,45 kg.) of refrigerant. In some cases when the ambient temperature is low, it may be necessary to start the engine and switch on the system in order to draw in the refrigerant. Run the engine for a further ten minutes with the blower motors at full speed.
2. Switch off the system and stop the engine.

Chapter C

3. Allow 5–10 minutes for the refrigerant pressure to equalise.

4. If loss of refrigerant pressure is apparent the system should be checked for leaks using an electrical leak detector. If the system maintains its pressure it is ready for charging upon completion of the sweeping operation.

Refrigeration system—To charge

1. Before charging the system, it is necessary to repeat the evacuation process and pull a vacuum of 28 in. Hg. for 30 minutes.

2. Attach a cylinder of refrigerant to the appropriate connection on the vacuum pump apparatus. Open the valve on the cylinder and purge the line between the cylinder and the vacuum pump apparatus. Suspend the cylinder on a spring balance and note its weight. Open the tap on the vacuum pump apparatus to enable the refrigerant to flow into the system.

3. Start the engine, and run at 1,000 r.p.m. to 1,250 r.p.m. Open the refrigeration outlet ducts, select 4th position on the refrigeration control knob and select $\frac{1}{2}$ blower speed. When 1 lb. (0.45 kg.) of refrigerant has passed into the system, close the tap on the vacuum pump apparatus and switch off the engine. Check all joints in the system for leaks with an electrical leak detector. If the system is leak free, repeat the charging operation to increase the weight of the refrigerant in the system to 3.5 lb. (1.59 kg.). If a leak or leaks are detected they must be rectified and the whole evacuation and charging operation repeated.

Note The presence of bubbles or foam passing through the receiver/drier sight glass is

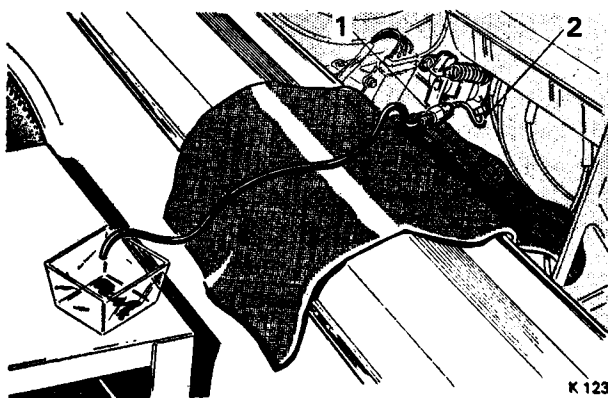

FIG. C16 DISCHARGING THE REFRIGERATION SYSTEM

- 1 'Schrader' valve adaptor (RH 7937)
- 2 Service pipe

not a reliable indication of refrigerant deficiency if the ambient temperature is below 23.9°C. (75°F).

4. Refit the 'Schrader' valve cap on the suction throttling valve when the charging operation is completed.

5. Again check the system for leaks using an electrical leak detector.

*** Oil level—To check**

The compressor sump was originally filled with 10.5 fluid ounces U.S. (310 c.c.) of 'Frigidaire' 525 Viscosity Oil. During normal system operation an affinity of the refrigerant for oil causes a certain amount of oil to circulate through the system with the refrigerant.

If a major loss of oil has occurred due to a severe compressor seal leak, line breakage or component failure, proceed as follows after making the necessary repairs.

Remove the compressor (see Section C5).

Drain the compressor oil into a clean measuring flask; record reading and discard the oil.

Pour into a clean measuring flask a quantity of new refrigerant oil, the amount being determined by the following.

If the oil drained from the compressor is more than 4.0 fluid ounces U.S. (125 ml) top-up the compressor with an equivalent amount of new compressor oil.

If the oil drained from the compressor is less than 4.0 fluid ounces U.S. (125 ml) and a major oil loss has occurred, fill the compressor with 6.0 fluid ounces U.S. (185 ml) of compressor oil.

If the compressor has been overhauled, increase the quantities given in the two previous paragraphs by 1.0 fluid ounce U.S. (29.5 c.c.).

If there is no indication of oil leakage in the system or from the compressor and the compressor is to be overhauled, drain and measure the oil as already described, then pour the equivalent quantity of clean oil into the compressor after overhaul.

If the compressor is to be renewed instead of overhauled, the oil contained in the new compressor should be drained into a clean measuring flask. This quantity should then be adjusted until the amount is 6 fluid ounces U.S. (185 ml.),

The resultant quantity of clean oil in the flask should then be poured into the new compressor.

Section C5 COMPRESSOR

Compressor—To remove

1. Discharge the refrigerant (see Section C4).
2. Disconnect the battery.
3. Disconnect the two 'Lucar' terminals from the compressor clutch.
4. Disconnect the flexible high pressure feed hose from the rear of the compressor.
5. Disconnect the flexible low pressure return hose from the front of the compressor.
6. Remove the two $\frac{9}{16}$ in. A/F setscrews securing the metal low pressure return pipe to the compressor body.
7. Slacken the alternator mounting bolts and the Vee belt tensioner and swing the unit toward the centre of the engine.
8. Remove the two compressor drive Vee belts.
9. Remove the setscrews and bolts securing the compressor to the engine.
10. Lift the compressor from the engine and lay it, with the sump downward, on a bench.

Compressor—To fit

1. To fit the compressor, reverse the procedure given for its removal, noting that the full procedure of evacuation and sweeping must be carried out before charging the system.

Overhaul

(see Figs. C17 and C18)

List of parts required for compressor overhaul

Whenever a major overhaul or rebuild is carried out it is recommended that an adequate stock of service parts be made available which should include the following:

- (a) Standard size piston drive balls.
- (b) Shoe discs—total of eleven sizes, including the ZERO shoe.
- (c) Thrust races—total of sixteen sizes, including the ZERO race.
- (d) Piston and rings.
- (e) Main shaft needle bearings.
- (f) Thrust bearings.
- (g) Compressor shaft, swash plate and Woodruff key assembly.
- (h) Suction reed valve, front, rear.
- (i) Gasket service kit—containing all gaskets, seals, 'O' rings, etc.
- (j) Discharge valve assembly, front, rear.
- (k) Shaft seal kit.
- (l) Nuts, head to shell and shaft.
- (m) Retainer rings.
- (n) Cylinder locating dowels.
- (o) Valve and head locating dowels.
- (p) Service discharge cross-over tube kit.

All service parts are protected by a preservation process and packed in a manner that will eliminate the necessity of cleaning or washing of the parts to be fitted.

Hub and drive assembly—To remove

1. Using the special clutch hub and holding tool RH 7798 (J-9403), remove and discard the compressor shaft lock-nut.
2. Withdraw the hub and drive-plate assembly using the special puller RH 7800 (J-9401); retain the key.

Note The puller must be screwed into its seat to prevent the hub and drive-plate assembly threads being damaged.

3. Remove the circlip and hub spacer washer.
4. Examine the clutch friction face for signs of wear or overheating, and check further for the underlying cause of the damage, e.g. low coil voltage or binding of the compressor internal mechanism.

Chapter C

Hub and drive assembly—To fit

1. When the hub is ready for installation, clean its frictional face with a suitable solvent cleaner. Locate the key in the compressor shaft key-way allowing it to project approximately $\frac{3}{16}$ in. (4,76 mm.) from the end of the key-way. Locate the hub assembly on the key-way and, using the special hub and drive-plate fitting tool RH 7799 (J-9480) and a suitable distance piece, draw the hub and drive assembly onto the shaft

until there is approximately $\frac{3}{32}$ in. (2,38 mm.) space between the frictional surfaces of the drive-plate and pulley.

Remove tool RH 7799 (J-9480) and distance piece.

Note Do not hammer or force the assembly onto the shaft. Always use the correct tools when removing or replacing clutch parts or serious damage may result to the internal components of the compressor.

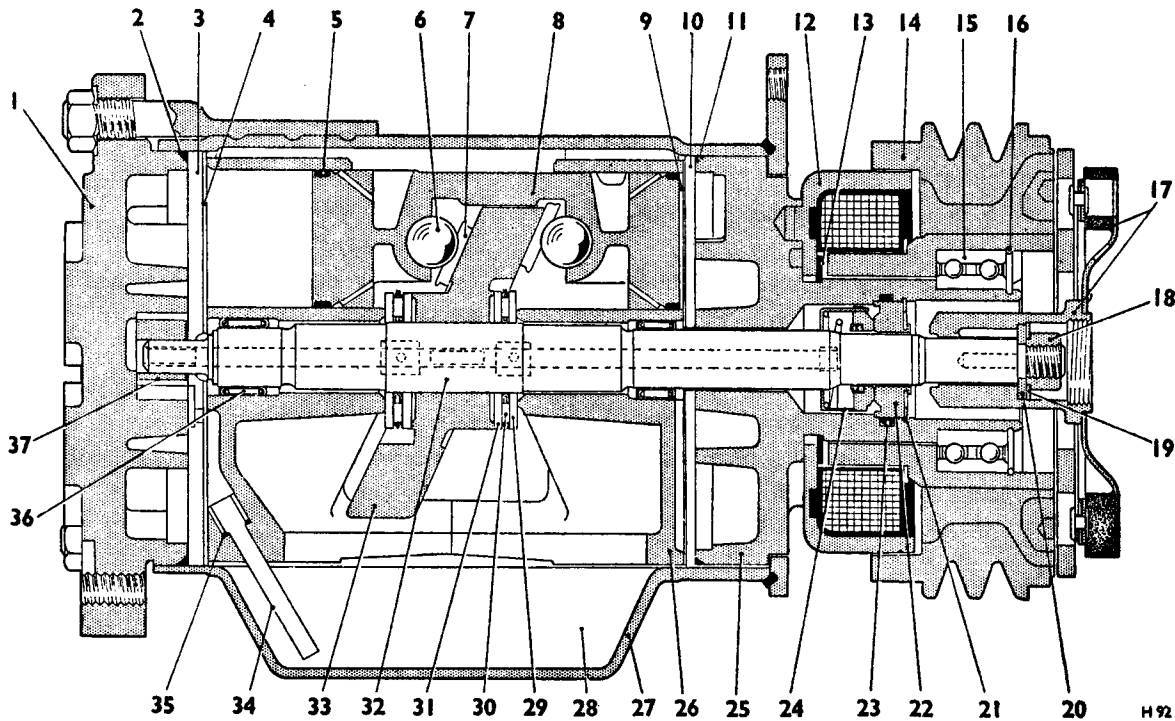

FIG. C17 SECTION VIEW OF REFRIGERANT COMPRESSOR

- | | | |
|---------------------------------|--|------------------------------|
| 1 Rear head | 13 Coil housing retainer ring | 25 Front head |
| 2 Rear head to shell 'O'-ring | 14 Pulley | 26 Cylinder assembly |
| 3 Rear discharge valve plate | 15 Pulley bearing | 27 Compressor shell |
| 4 Rear suction reed plate | 16 Pulley bearing retainer circlip | 28 Oil sump |
| 5 Piston ring | 17 Clutch hub and drive-plate assembly | 29 Thrust race |
| 6 Piston drive ball | 18 Shaft nut | 30 Thrust bearing |
| 7 Shoe disc | 19 Clutch hub retainer ring | 31 Thrust race |
| 8 Piston | 20 Spacer | 32 Mainshaft |
| 9 Suction reed plate | 21 Shaft seal seat retainer ring | 33 Swash plate |
| 10 Front discharge valve plate | 22 Shaft seal seat | 34 Oil pick-up tube |
| 11 Front head to shell 'O'-ring | 23 Shaft seal seat 'O'-ring | 35 Oil pick-up tube 'O'-ring |
| 12 Coil and housing assembly | 24 Shaft seal | 36 Mainshaft bearing |
| | | 37 Oil pump gears |

2. Fit the hub spacer washer and circlip with the convex side of the clip facing the washer.

3. Fit a new lock-nut and torque tighten to 15 lb.ft. (2,07 kg.m.). The air gap between the frictional faces should now be between 0.022 in. and 0.057 in. (0,558 mm. and 1,447 mm.).

Note The shoulder or circular projection on the lock-nut must face toward the circlip.

4. To 'bed-in' the clutch parts, run the engine and, by switching the refrigeration system off and on 20 times at approximately 1 second intervals, cycle the clutch assembly.

Pulley and bearing assembly—To remove

1. Remove the hub and drive assembly.
2. Remove the circlip retaining the pulley bearing and centre shaft key.
3. Fit the special puller pilot RH 7792 (J-9395) over the compressor shaft and using special puller RH 7791 (J-8433) withdraw the pulley assembly.
4. Check for excessive grooving in the clutch hub and drive-plate; renew parts if necessary.

Bearing—To remove

1. With the pulley and bearing assembly removed from the compressor, use a sharp pointed instrument to remove the wire retainer ring.
2. Press the bearing out of the pulley housing using special bearing puller RH 7795 (J-9398) with handle RH 7794 (J-8092).

Bearing—To fit

- ★ 1. Using the special puller RH 7796 (J-9481) and handle RH 7794 (J-8092), press the new bearing into the pulley.
- 2. Fit the bearing retainer ring.

Pulley and bearing assembly—To fit

- ★ 1. Using special tool RH 7796 (J-9481) press the pulley and bearing assembly onto the compressor shaft. Ensure that the pulley will rotate freely.
- 2. Fit the pulley retainer ring, the hub and drive-plate assembly and the retainer ring.

Coil housing—To remove

1. Following the removal of the hub and drive-plate assembly and the pulley bearing assembly, disconnect the two 'Lucar' terminals.
2. Scribe a mark on the coil housing and a corresponding mark on the compressor body.
3. Remove the circlip securing the coil to the compressor body.

Coil housing—To inspect

1. Examine the coil for loose terminals or cracked insulation.

Coil housing—To fit

1. Fit the coil housing in its correct position as indicated by the scribed marks.
2. Fit the circlip (flat face to coil housing).
3. Fit the hub and drive-plate assembly and the pulley bearing assembly.
4. Connect the 'Lucar' terminals and check the clutch for correct operation.

Compressor shaft seal assembly— To remove

1. Discharge the refrigerant.
2. Remove the clutch plate and hub assembly.
3. Remove the seal seat retainer ring.
4. Locate the flanges of seal seat remover RH 7802 (J-9393) in the groove of the seal seat; withdraw the seal seat.
5. Place the seal seat remover RH 7793 (J-9392) over the compressor shaft and by pressing downward (to overcome seal spring pressure) turn the seal seat remover clockwise to engage the tabs on the seal assembly; withdraw the seal.
6. Remove the 'O' ring from the interior of the front head casting bore.

Compressor shaft seal assembly— To fit

1. Thoroughly clean the front head bore and fit a new 'O' ring in the bottom groove.
2. Immerse the shaft seal in clean compressor oil before fitting to prevent the shoulder from damaging the 'O' ring.
3. Using special seal installer RH 7793 (J-9392) fit the shaft seal over the flats on the compressor shaft with the carbon seal facing upwards; turn the seal installer anti-clockwise to release the seal.
4. Insert the seal seat into the front head bore taking care not to dislodge the 'O' ring; use tool RH 7802 (J-9393).

Note The contact surface of the seal must be protected against any damage, such as scratches and nicks. Finger marks may cause surface damage.

5. Insert the retainer ring (flat side down) until the retainer rests on the seal seat. Using seal seat installer RH 7802 (J-9393), press the retainer ring until the spring pressure of the shaft seal is overcome and the retainer ring snaps into the groove in the casting bore.

Chapter C

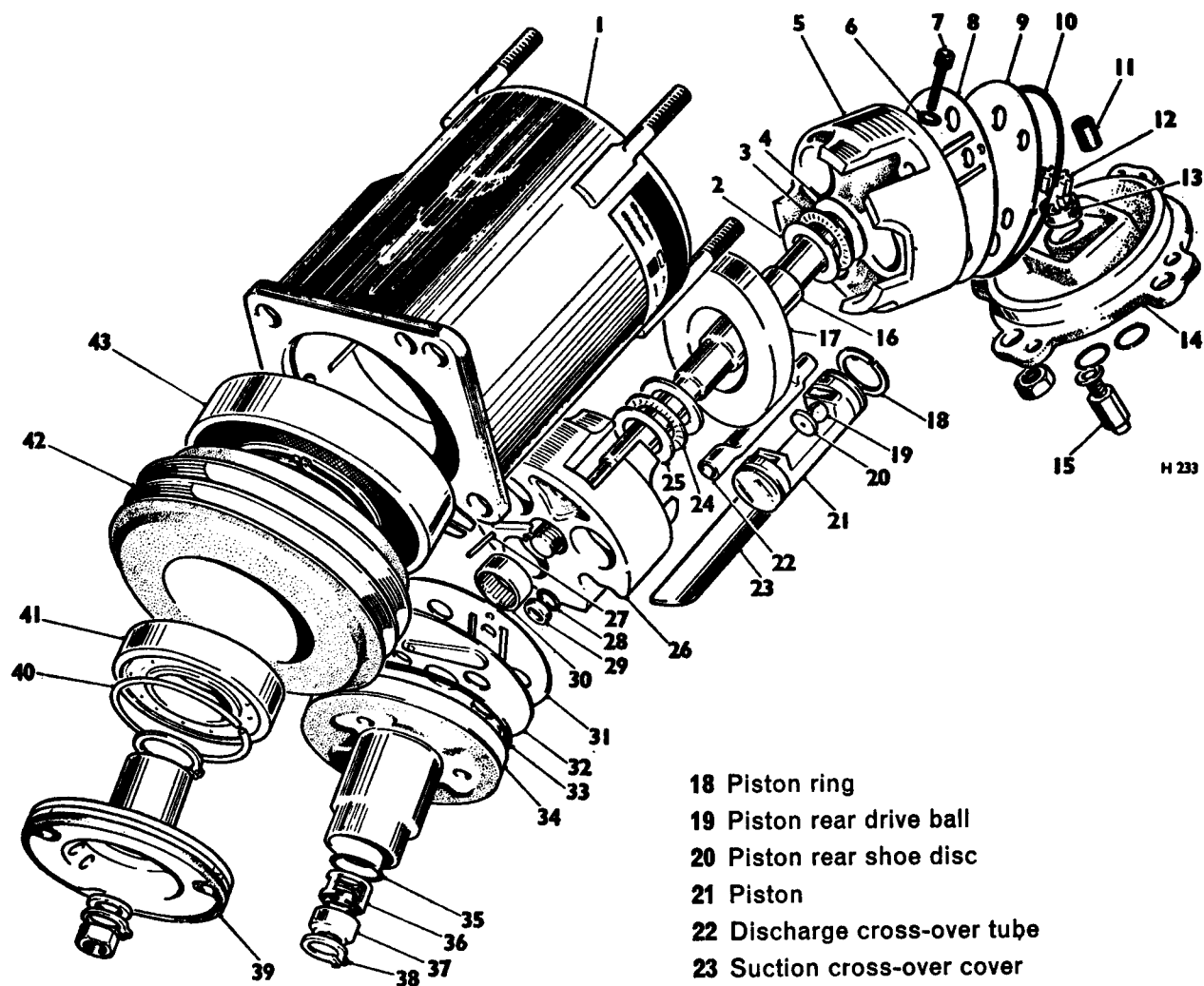

FIG. C18 EXPLODED VIEW OF REFRIGERANT COMPRESSOR

1 Compressor shell

2 Thrust race

3 Bearing

4 Thrust race

5 Rear cylinder half

6 Oil pick-up tube 'O'-ring

7 Oil pick-up tube

8 Rear suction reed plate

9 Rear discharge valve plate

10 Rear head to shell 'O'-ring

11 Strainer screen

12 Oil pump drive gear

13 Oil pump driven gear

14 Compressor rear head

15 High pressure relief valve

16 Mainshaft

17 Swash plate

18 Piston ring

19 Piston rear drive ball

20 Piston rear shoe disc

21 Piston

22 Discharge cross-over tube

23 Suction cross-over cover

24 Bearing

25 Thrust race

26 Front cylinder half

27 Drive key

28 Discharge cross-over tube front 'O'-ring

29 Discharge cross-over tube spacer

30 Mainshaft front bearing

31 Front suction reed plate

32 Front discharge valve plate

33 Front head to shell 'O'-ring

34 Compressor front head

35 Shaft seal seat 'O'-ring

36 Shaft seal

37 Shaft seal seat

38 Shaft seal seat retainer ring

39 Clutch hub and drive-plate assembly

40 Pulley bearing retaining circlip

41 Pulley bearing

42 Pulley

43 Coil housing

H 233

Internal mechanism—To remove

1. Remove the clutch, the pulley assembly, the clutch coil and the shaft seal as previously instructed in this Section.

2. Invert the compressor and drain the oil into a measuring cup. This operation is necessary to ensure that, on assembly, the compressor is filled with the correct amount of oil.

3. Remove the four lock-nuts securing the rear head to the compressor shell then remove the compressor head.

4. Wipe any excess oil from the teflon gasket surfaces on the rear head casting webs and examine for damage (*see Fig. C19*); renew the rear head if necessary.

5. Remove the suction filter and examine it for damage or obstruction; clean or renew if necessary.

6. Paint or etch suitable marks on the oil pump gears; this is to ensure that the gears, if used for assembly, will be fitted in their identical positions.

7. Remove and discard the rear head 'O' ring.

8. Carefully lift the rear discharge valve plate assembly by using two small screwdrivers under the valve reed retainers. Do not position the screwdrivers between the reeds and the reed seats.

9. Examine the valve reeds and seats for damage; renew if necessary.

10. Withdraw the oil pick-up tube using a stiff piece of hooked wire (*see Fig. C20*); discard the 'O' ring.

11. Invert and rest the compressor assembly on support block RH 7803 (J-9521).

12. Lift off the compressor shell and front head assembly leaving the internal mechanism resting on the support block.

Note If the internal mechanism will not separate from the compressor case, tap the compressor head and not on the end of the compressor shaft.

13. Wipe any excess oil from the teflon gasket surfaces on the front head casting webs and examine for damage; renew the front head if necessary.

14. Carefully lift the front discharge valve plate assembly by using two small screwdrivers under the valve reed retainers. Do not position the screwdrivers between the reeds and the reed seats.

15. Examine the valve reeds and seats for damage; renew if necessary.

16. Remove the suction cross-over cover from the cylinder casting.

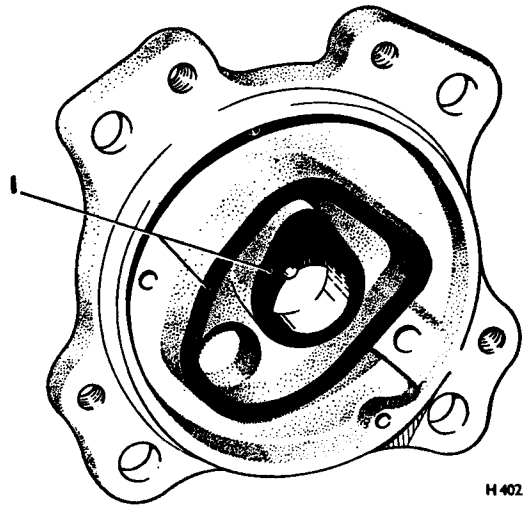

H 402

FIG. C19 COMPRESSOR REAR HEAD

1 Teflon gasket surfaces

Cylinder assembly—To dismantle

1. Etch or mark by some suitable means, each piston and its respective bore to ensure correct assembly.

2. Using a wooden block and mallet separate the cylinder halves (*see Fig. C21*), taking care that the discharge cross-over tube does not foul the swash plate.

Important Under no circumstances should the compressor shaft be hit at either end in an effort to separate the cylinder halves.

3. Place the complete internal mechanism rear cylinder downwards on support block RH 7803 (J-9521); remove the front cylinder half.

4. Turn the compressor shaft until the piston marked 1 is fully raised; remove the piston.

5. Discard the piston shoe discs. Examine the piston drive balls for signs of pitting or surface cracking; renew if necessary.

6. Remove and discard the piston rings. Place the piston with the drive balls in the parts tray RH 7801 (J-9402).

7. Repeat Operations 4 to 6 inclusive for No. 2 and 3 pistons ensuring that all parts are kept with their respective pistons.

8. Remove and discard the front combination of thrust races and thrust bearings.

9. Remove the swash plate and shaft assembly from the rear cylinder half. It may be necessary to bend the discharge cross-over tube slightly to facilitate shaft removal.

Chapter C

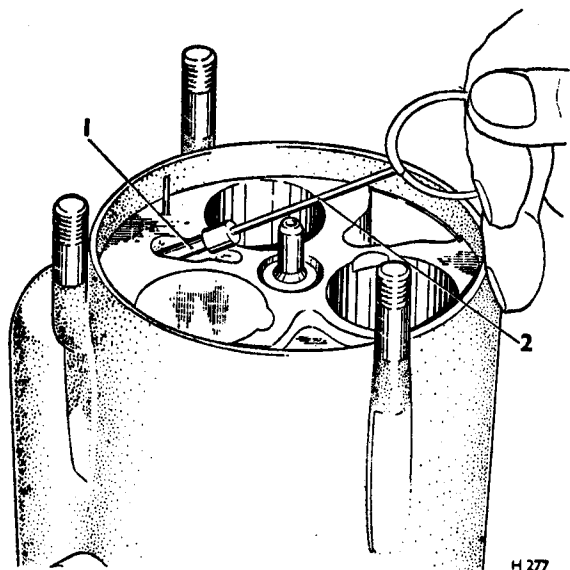

FIG. C20 REMOVING THE OIL PICK-UP TUBE

- 1 Oil pick-up tube
- 2 Wire hook

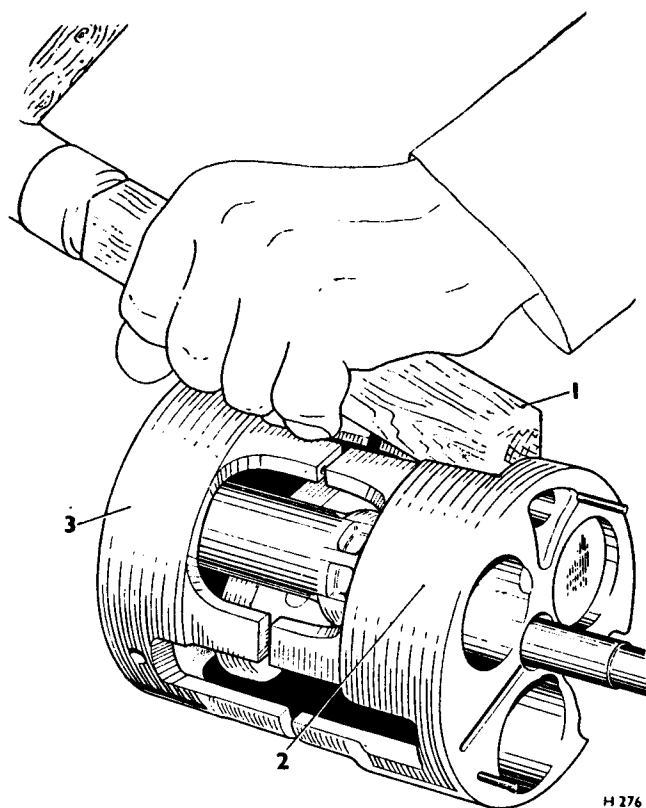

FIG. C21 SEPARATING THE CYLINDER HALVES

- 1 Wooden block
- 2 Front cylinder half
- 3 Rear cylinder half

10. Remove and discard the rear combination of thrust races and thrust bearings.

11. Examine the swash plate surface and shaft; renew as an assembly if necessary.

Note A certain amount of shoe disc wear on the swash plate together with marks indicating needle bearing load on the shaft are normal.

12. Remove the discharge cross-over tube from the cylinder half; use vice grip pliers.

Note Operation 12 is necessary on original factory equipment as the ends of the tube are swaged into the cylinder halves. The discharge cross-over tube, in previously overhauled units has an 'O' ring and bush at each end of the tube and can easily be removed by hand.

13. Examine the piston bores and needle bearings in the front and rear cylinder halves. Renew the front or rear cylinders if any cylinder bore is deeply scored or damaged.

14. Needle bearings may be removed if necessary by the use of a suitable punch. Fit the punch in the inner side of the cylinder head and drive the bearing out.

15. To fit the needle bearing, place the cylinder half on support block RH 7803 (J-9521).

16. Insert the bearing into the cylinder head with the bearing identification marks upward. Use the special needle bearing installer RH 7790 (J-9432) to drive the bearing into the cylinder head until the installer bottoms on the cylinder face.

Important All parts which are to be used again should be washed in 'Genklene', alcohol, or a similar solvent. Remove excess moisture with dry compressed air.

Compressor running clearances—To set

Before assembling the compressor, it is necessary to set the running clearances of the bearing surfaces in the following manner.

1. Place the compressing fixture RH 7789 (J-9397) on the bench (studs uppermost).
2. Place the front cylinder half in the compressing fixture, face downwards.
3. Fit a zero thrust race, thrust bearing and a second zero thrust race onto the front end of the compressor shaft. Lubricate the thrust races and thrust bearing with petroleum jelly.

4. Fit the threaded end of the shaft through the needle bearing in the front cylinder half and rest the shaft on the cylinder hub.

5. Fit a zero thrust race onto the rear end of the compressor shaft so that it rests on the hub of the swash plate then fit a thrust bearing and a second zero thrust race. Lubricate the thrust races and thrust bearing with petroleum jelly.

6. Lubricate the ball pockets of No. 1 piston with compressor oil and place a ball in each socket. Use the balls previously removed if they are in suitable condition.

7. Lubricate the cavity of a zero shoe disc with compressor oil and place the shoe disc over the ball in the front end of the piston.

Note The front end of the piston has an identification mark on the casting web.

8. Rotate the compressor shaft and swash plate until the high point of the swash plate is above No. 1 cylinder bore.

9. Lift the shaft assembly to enable the piston (identification mark downwards) to be fitted over the swash plate above No. 1 cylinder bore.

Note Piston rings should not be fitted for this operation.

10. Repeat Operations 6 to 9 inclusive for No. 2 and No. 3 pistons.

11. Fit the rear cylinder half over the pistons, aligning the discharge cross-over tube hole with that of the front cylinder. Tap the cylinder into place with a soft-headed mallet.

12. Position the compressor internal mechanism so that the discharge cross-over tube holes are mid-way between a pair of compressing fixture bolts.

13. Fit the top cover on the compressing fixture and torque tighten the four bolts to 15 lb.ft. (2,07 kg.m.).

Shoe disc—To select

1. Measure the clearance between the rear ball of No. 1 piston and the swash plate in the following manner.

2. Select a suitable combination of oiled feeler gauge leaves to fit neatly between the ball and swash plate.

3. Attach a spring scale reading in one ounce (one gramme) increments, to the feeler gauge.

4. Adjust the thickness of the feeler gauge until a reading of 4 to 8 ounces (113,4 to 226,8 grammes) on the spring scale is necessary to withdraw the feeler

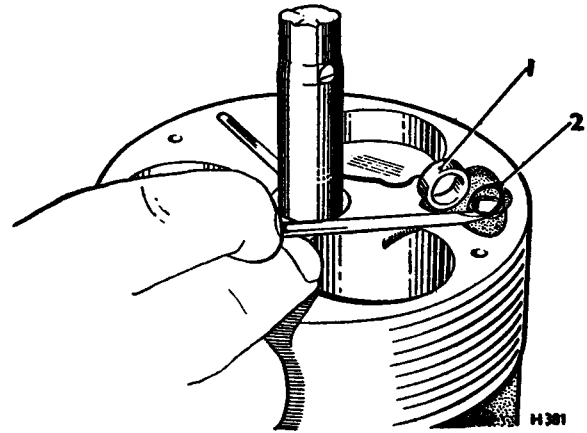

FIG. C22 FITTING THE CROSS-OVER TUBE 'O' RING

- 1 Spacer
- 2 'O'-ring

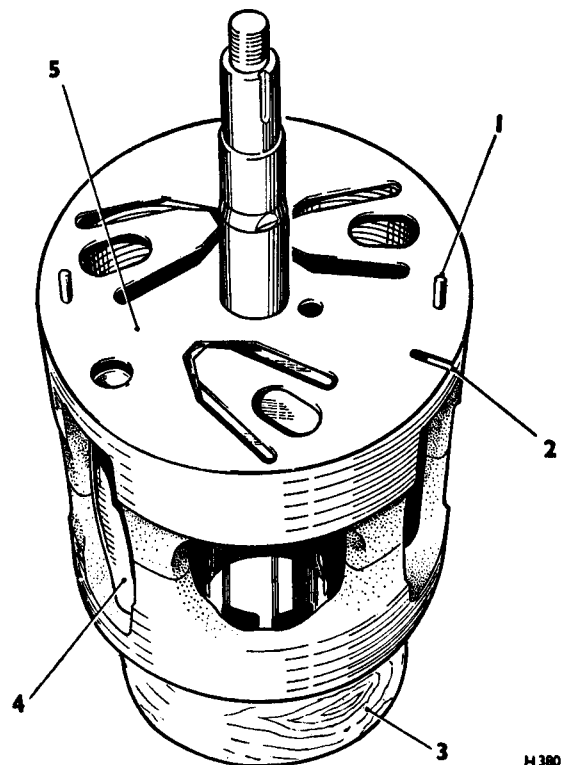

FIG. C23 FRONT SUCTION REED PLATE

- 1 Dowel pin
- 2 Oil return slot
- 3 Support block
- 4 Discharge cross-over tube
- 5 Front suction reed plate

Chapter C

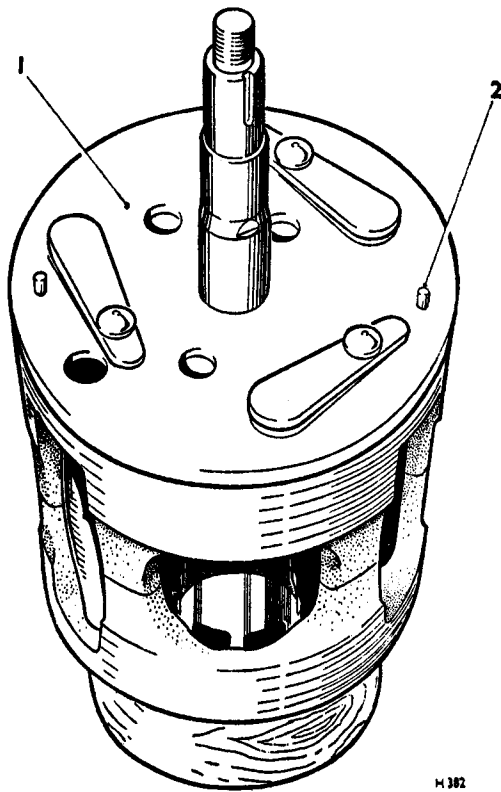

FIG. C24 FRONT DISCHARGE VALVE PLATE

- 1 Front discharge valve plate
- 2 Dowel pin

gauge from between the swash plate and piston ball; record the thickness of the feeler gauges.

5. Rotate the compressor shaft through 120° and repeat Operations 2 to 4 inclusive on same parts. Rotate the compressor shaft through a further 120 and again repeat Operations 2 to 4 inclusive on same parts.

6. Select a shoe disc corresponding to the minimum feeler gauge thickness recorded for the three checks on No. 1 piston.

7. Repeat Operations 1 to 6 inclusive for No. 2 and No. 3 pistons.

Compressor shaft thrust race—To select

1. Position a dial indicator on the rear end of the compressor shaft and adjust to zero. Push the shaft upwards and record the dial reading.

Note Dial indicator increments are 0.001 in. (0,025 mm.), therefore the reading must be estimated to the nearest 0.0005 in. (0,013 mm.).

2. Select an oversize thrust race equivalent to the dial gauge reading.

Note Fifteen thrust races are provided in increments of 0.0005 in. (0,013 mm.) above the zero washer size each with a tolerance of 0.0005 in. (0,013 mm.) to 0.0015 in. (0,038 mm.) to provide a running clearance between the hub surfaces of the swash plate and the front and rear hubs of the cylinder.

3. Dismantle the compressing fixture and remove the rear cylinder half, leaving the front cylinder half resting upon the compressing fixture.

4. Remove one piston at a time taking care not to lose the relationship of the front ball and shoe disc and the rear ball.

5. Remove the rear outer thrust race from the compressor shaft and replace it with the thrust race previously selected.

**Compressor internal mechanism—
To assemble**

1. Fit a piston ring to each of No. 1 piston with the scraper groove toward the swash plate.

2. Lubricate the piston ball pockets, the corresponding piston drive balls, the piston shoe discs and assemble them, place the zero shoe disc over the drive ball of the front piston.

3. Rotate the compressor shaft and swash plate until the high point of the swash plate is over No. 1 piston cylinder bore.

4. Lift the compressor shaft and place the piston over the swash plate with the identification mark toward the front cylinder head.

5. Position the piston ring with the gap toward the compressor shaft.

6. Repeat the procedure for pistons No. 2 and No. 3 taking care not to damage the piston rings.

7. Fit a new discharge cross-over tube in the front cylinder half with the flat surface facing the compressor shaft.

Note The service discharge cross-over tube is of similar design to that used on production except that an 'O' ring and bush are used at each end.

8. Position the rings on each piston so that the ring gaps are facing the compressor shaft, then push the rings outward.

9. Place the rear cylinder half over the compressor shaft and enter the pistons into their respective bores taking care not to break the piston rings.

10. When all the pistons and rings are located in their respective bores, align the end of the discharge cross-over tube with the hole in the rear cylinder half.

11. Ensure that the flat face of the discharge cross-over tube faces the compressor shaft and gently tap the rear cylinder half until it is seated on the front cylinder half.

12. Fit the suction cross-over cover into the grooves in the cylinder halves. Align the cover with the ends of the cylinder faces by gently tapping the end of the cover with a soft-headed mallet.

Compressor—To assemble

1. Place the internal assembly on to the support block RH 7803 (J-9521) with the oil pump drive in the block hole.

2. Fit a new 'O' ring and bush on to the front end of the discharge cross-over tube (see Fig. C22).

3. Fit new dowel pins to the cylinder head.

4. Fit the front suction reed plate and discharge valve plate assembly aligning the holes with the dowel pins and the correct openings (see Figs. C23 and C24).

Note The front discharge plate has a large diameter hole in the centre.

5. Coat the teflon gasket surfaces with the approved compressor oil.

6. Determine the exact position of the front head casting in relation to the dowel pins of the internal mechanism and mark the positions of the dowel pins on the sides of the front head assembly with a soft pencil. Carefully lower the front head casting into position.

7. Ensure that the teflon gasket around the cylinder head centre does not come into contact with the compressor shaft.

8. **Do not** rotate the head assembly to align it with the dowel pins as the teflon gasket may contact the reed retainers.

9. Lubricate the angled groove at the lower edge of the front head casting with compressor oil.

10. Position the compressor shell over the front head and with the aid of a small screwdriver gently press in the 'O' ring around the circumference of the internal mechanism until the compressor shell will slide over the internal mechanism without damage to the 'O' ring.

11. Invert the compressor and fit new dowels and the oil pick-up 'O' ring in the cylinder head.

12. Lubricate the oil pick-up tube and fit it in the cylinder head passage; if necessary, rotate the internal mechanism to align the oil pick-up tube with the hole in the sump baffle.

13. Fit a new 'O' ring and bush on the discharge cross-over tube.

14. Fit the suction reed with the oil drain slot adjacent to the sump.

15. Fit the rear discharge plate.

16. Place the inner and outer oil pump gears over the compressor shaft (identification marks together).

17. Position the gears as shown in Figure C25.

18. Lubricate around the outer edge of the rear discharge valve plate, the valve reeds, pump gears and the area which the teflon sealing surface will contact on the rear discharge valve plate.

19. Lubricate the new head to shell 'O' ring and place on the discharge valve plate.

20. Fit the suction filter in the rear head casting and coat the teflon sealing surface with compressor oil.

21. Place the rear head assembly over the studs on the compressor shell. The two lower, threaded, compressor mounting holes should be in alignment with the compressor sump. Ensure that the suction filter does not drop out of place when lowering the cylinder head into position.

22. Fit nuts and torque tighten evenly to 20 lb.ft. (1,41 kg.m.).

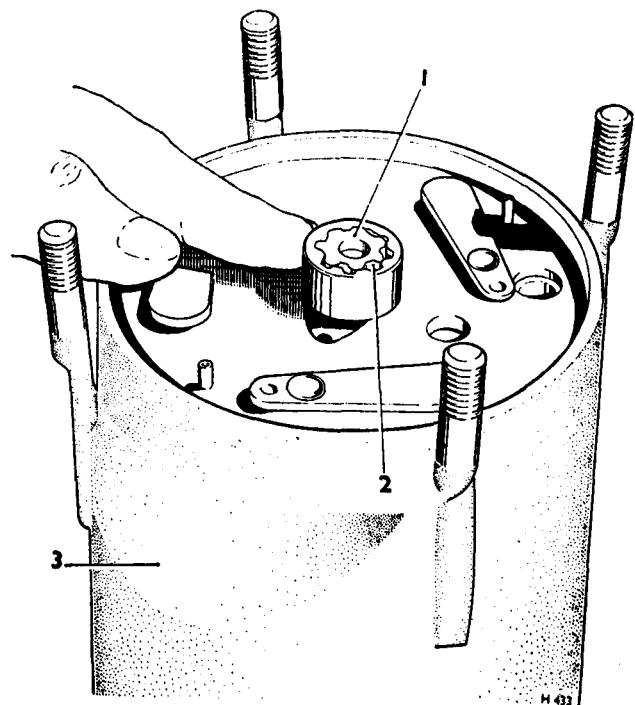

FIG. C25 POSITIONING THE OIL PUMP GEARS

- 1 Inner gear
- 2 Cavity between gear teeth
- 3 Compressor body

Chapter C

23. Fit the shaft seal, clutch coil, compressor pulley and bearing assembly and compressor clutch plate and hub assembly as described earlier in this Section.

24. Add the approved compressor oil to the compressor—refer to Compressor oil level—To check (see Page C20).

25. Before operating the compressor, rotate the clutch hub (clockwise) several times to circulate compressor oil to the piston rings and oil seals.

26. Upon assembly of the refrigeration system, the full process of evacuation and sweeping must be carried out before charging the system.

Section C6

SUCTION THROTTLING VALVE AND EXPANSION VALVE

Suction throttling valve—To remove (see Fig. C27)

1. Discharge the refrigerant (see Section C4).
2. Disconnect the suction hose fitted between the compressor and the suction throttling valve.
3. Slacken the outlet and inlet pipes to the suction throttling valve.
4. Disconnect the suction hose from the suction throttling valve.
5. Remove the suction throttling valve extension pipe.
6. Disconnect the equalising pipe from the expansion valve.
7. Slacken the pinch bolt securing the actuator crank lever to the actuator spindle.
8. Remove the bolts securing the suction throttling valve to its mounting bracket.
9. Disconnect the clip securing the suction hose to the hydraulic reservoir mounting bracket.
10. Remove the suction throttling valve.

Suction throttling valve—To fit

Fit the suction throttling valve by reversing the procedure given for its removal, noting the following points.

1. The inlet pipe from the toeboard should be connected to the suction throttling valve before any other connections are fitted and before the suction throttling valve is mounted.
2. Fit and set the actuator lever to its spindle as described in Section C6.
3. Fit new 'O' rings and lubricate all threads and connections with the approved compressor oil.

★ Suction throttling valve—To dismantle (see Fig. C26)

1. Remove the two springs from the operating arm.
2. Remove the charging pipe.
3. Scribe correlation marks on the valve body and cover to ensure correct positioning on assembly.
4. With the valve cover held firmly down on the valve body, remove the five cover securing screws then, slowly allow the cover to separate from the body and collect the three springs, spring seats and spacing washer.

Care must be taken during this operation due to the strong compression force of the valve spring.

5. Withdraw the diaphragm and piston assembly from the body; care should be taken when handling the diaphragm to avoid damaging the rubber and fabric surfaces.

Note The filter screen and retainer in the base of the piston should not be removed.

Suction throttling valve—To inspect

1. Examine the valve body bore and also the piston surfaces for any imperfections, foreign material and any obvious damage that would cause the piston not to operate freely. Renew any parts which are damaged; do not attempt to scrape, stone or dress out any damage. Examine the diaphragm for cuts and tears and if necessary renew the diaphragm and piston assembly.
2. Check that the springs are not broken, particularly the ends and renew as necessary.

Chapter C

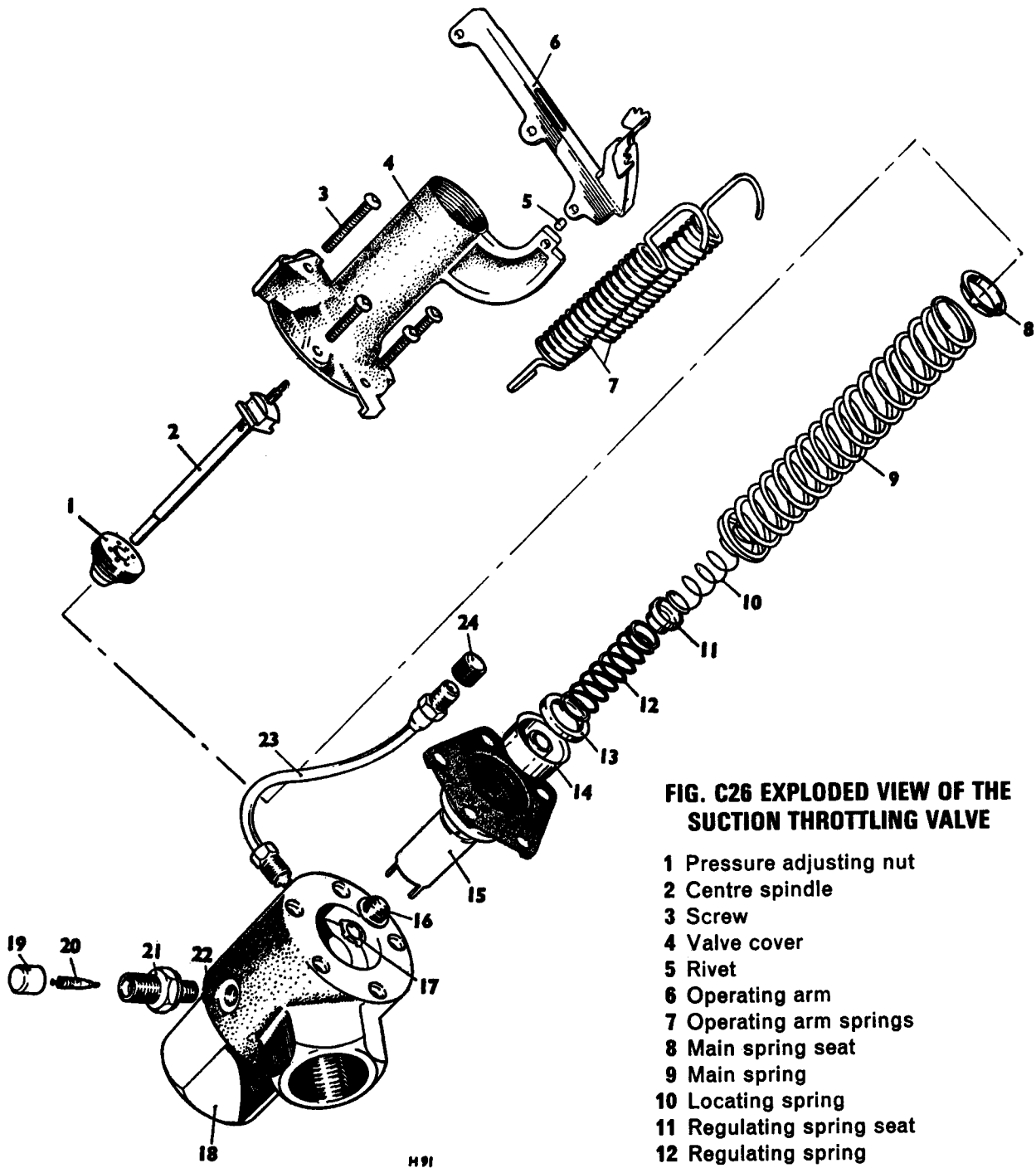

FIG. C26 EXPLODED VIEW OF THE SUCTION THROTTLING VALVE

- 1 Pressure adjusting nut
- 2 Centre spindle
- 3 Screw
- 4 Valve cover
- 5 Rivet
- 6 Operating arm
- 7 Operating arm springs
- 8 Main spring seat
- 9 Main spring
- 10 Locating spring
- 11 Regulating spring seat
- 12 Regulating spring
- 13 Spacing washer
- 14 Main spring seat
- 15 Piston and diaphragm assembly
- 16 Filter screen
- 17 Filter screen retainer
- 18 Valve body
- 19 Valve cap (if fitted)
- 20 'Schrader' valve (if fitted)
- 21 'Schrader' valve adaptor (if fitted)
- 22 Sealing ring
- 23 Charging pipe
- 24 Cap

★ Suction throttling valve—To assemble

(see Fig. C26)

1. Using Genklene or alcohol, thoroughly clean all the valve components including the screen in the base of the piston then dry with a compressed air line; note that the screen should not be removed from the piston.
2. Lightly coat the diaphragm and piston assembly with refrigerant oil then fit the assembly into the valve body; press the centre of the diaphragm until the piston seats against the inner shoulder in the valve body.
3. Assemble the main spring upper seat, main spring, locating spring, regulating spring seat, regulating spring, spacing washer and main spring lower seat into the valve cover in this sequence (see Fig. C26), holding the assembled parts together; ensure that the spindle in the cover passes through the centre of the springs and seats.
4. Fit the assembled cover, springs and seats to the valve body ensuring that the main spring lower seat locates into the centre of the diaphragm and that the correlation marks on the valve body and cover are aligned.

Guide rods approximately 4 in. (10.2 cm.) long, placed temporarily in three of the screw holes in the valve body will greatly assist in aligning the body and cover.

5. Press down on the top cover until it contacts the diaphragm then fit two of the cover securing screws; do not fully tighten the screws at this stage.

Firm pressure will be required when pressing down the cover to overcome the pressure of the valve spring.

6. Remove the temporary locating rods then fit the three remaining cover securing screws; ensure that the diaphragm is positioned correctly between the body and cover then tighten the five screws evenly and firmly.
7. Move the operating arm up and down and ensure that the centre spindle is not binding.
8. Fit the charging pipe.

9. Fit the suction throttling valve to the car as previously described then adjust the valve as follows.

Note that after fitting and adjusting the suction throttling valve it will be necessary to check the valve pressure and adjust if necessary (see Suction throttling valve pressure – To adjust, in this Section).

Suction throttling valve—To adjust

1. The system should be evacuated, swept and charged prior to adjusting the suction throttling valve.
2. Adjust the positions of the 5 B.A. nuts on either side of the swivel pin so that it is possible to rotate the crank (with the pinch bolt slack) for a full turn about the actuator spindle without binding or distortion taking place. Lock the 5 B.A. nuts against the swivel pin.
3. Remove the two springs from the suction throttling valve operating arm and by turning the spindle, which is screwed through a plastic bush located in the centre of the operating arm, reduce the free play of the operating arm.

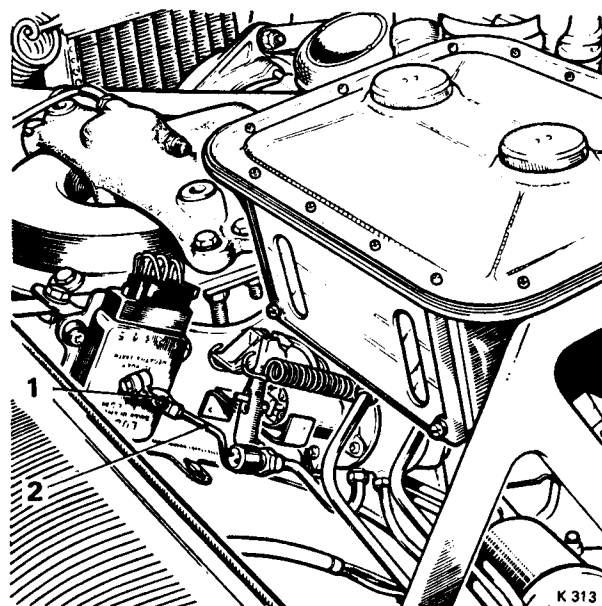

FIG. C27 SUCTION THROTTLING VALVE ACTUATOR SETTING

- 1 Actuator crank lever
- 2 Link rod

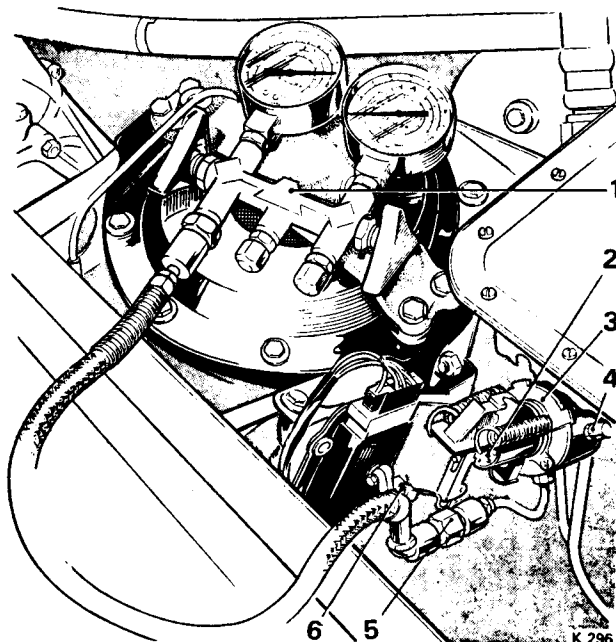

FIG. C28 SUCTION THROTTLING VALVE WITH PRESSURE GAUGE

- 1 Pressure gauges
- 2 Pressure adjusting nut
- 3 Suction throttling valve
- 4 Blanking plug
- 5 Charging pipe
- 6 Actuator linkage

Chapter C

4. Check to ensure that the spindle does not bottom within the valve by turning the crank through a complete revolution every $\frac{1}{2}$ turn clockwise of the spindle.
5. When bottoming does occur, turn the spindle one turn anti-clockwise and fit the springs.
6. Secure the lever to the actuator spindle (see Section C6—Suction throttling valve actuator linkage—To adjust).

**Suction throttling valve pressure—
To adjust
(see Fig. C28)**

1. Remove the 'Schrader' valve cap from the suction throttling valve gauge connection.
2. Fit the 'Schrader' valve adaptor to a flexible hose and gauge, which in turn should be connected to the suction throttling valve.
3. Purge the air from the hose by loosening the connection on the pressure gauge for a few seconds.

4. Start and run the engine at a speed of between approximately 1,000 r.p.m. and 1,250 r.p.m.; select maximum blower speed with all refrigerant outlets open.
5. Turn the 'UPPER' facia switch fully anti-clockwise then back to the 'off' position so that the actuator crank makes a full turn. Repeat this operation ten times to normalise the suction throttling valve diaphragm.
6. Allow the system to operate for a further 5 minutes until pressure in the system becomes stable.
7. Slowly increase the engine speed until the gauge pressure ceases to fall and the suction throttling valve can be seen to control the pressure by the slight hunting of the gauge needle.

The stabilised suction throttling valve pressure should be between 29 lb./sq. in. and 30 lb./sq. in. (2.03 kg./sq. cm. and 2.11 kg./sq. cm.) gauge reading.

★ If it is necessary to adjust the suction throttling valve, rotate the pressure adjusting nut (see Fig. C28) using the special adjusting tool (RH 7934). Clockwise rotation increases the pressure, anti-clockwise rotation decreases the pressure.

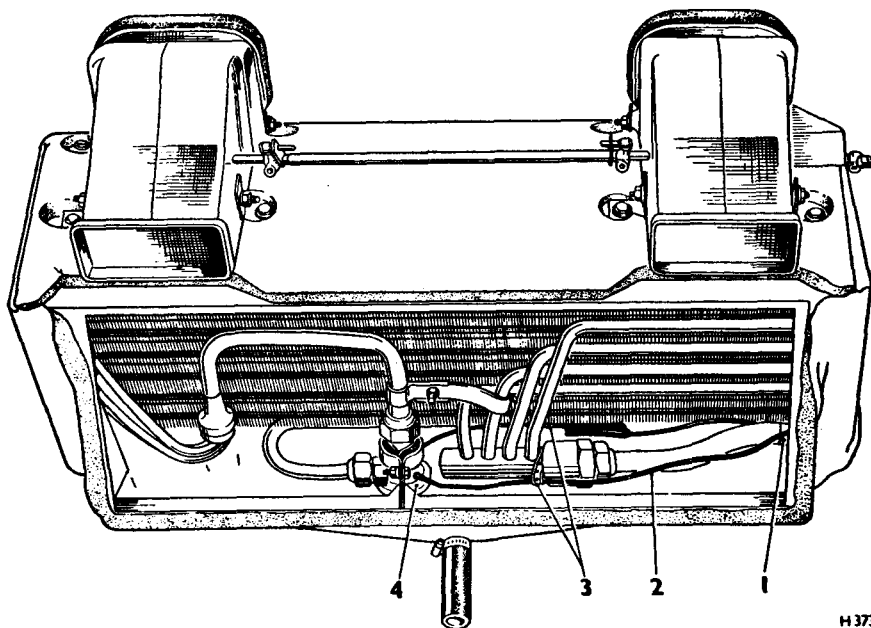

H 373

FIG. C29 POSITION OF EXPANSION VALVE IN EVAPORATOR BOX (Early cars)

1 Cup 2 Equalising pipe 3 Clips 4 Expansion valve

Suction throttling valve pressures

Switch Position	Approximate Gauge Pressure
1st	52 lb./sq. in. to 54 lb./sq. in. (3,66 kg./sq. cm. to 3,79 kg./sq. cm.)
2nd	46 lb./sq. in. to 48 lb./sq. in. (3,23 kg./sq. cm. to 3,37 kg./sq. cm.)
3rd	34 lb./sq. in. to 36 lb./sq. in. (2,39 kg./sq. cm. to 2,53 kg./sq. cm.)
4th	29 lb./sq. in. to 30 lb./sq. in. (2,03 kg./sq. cm. to 2,11 kg./sq. cm.)

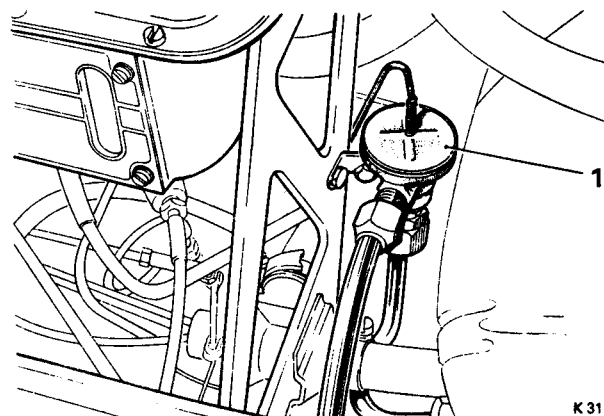

FIG. C30 POSITION OF EXPANSION VALVE
(Late cars)

1 Expansion valve

Expansion valve—To remove**Early cars.**

(Refer to Figure C29)

1. Discharge the refrigeration system (see Section C4).
2. Remove the radio and the small trim panels fitted to either side of the radio; refer to Chapter M.
3. Remove the drain tube from the underside of the evaporator box.
4. Using a sharp razor knife, cut the stitching along the bottom corners of the evaporator box; fold back the insulating material. On later cars the insulating material is kept into place with press studs, it is therefore only necessary to undo the press studs.
5. Remove the self tapping screws securing the bottom tray to the evaporator box; remove the tray.
6. Lower the steering column (right-hand drive cars only); refer to Chapter N and unwrap the insulating material covering the refrigerant circulation pipes.
7. Disconnect the expansion valve balance pipe at the engine bulkhead.
8. Disconnect the two refrigerant pipes at the expansion valve body.
9. Remove the metal clip securing the expansion valve thermal bulb to the low pressure outlet pipe.
10. Remove the plastic strap securing the capillary tube to the four pass manifold.
11. Remove the bolt securing the expansion valve body clamp to the evaporator box.

12. Withdraw the expansion valve and at the same time feed the capillary balance pipe through the evaporator case.

Late cars.

(Refer to Figure C30)

1. Discharge the refrigerant (see Section C4).
2. Disconnect the equaliser pipe at the suction throttling valve.
3. Remove the putty insulation, surrounding the thermal bulb at the suction throttling valve inlet pipe.
Slacken the clip securing the thermal bulb to the pipe then slide the bulb clear of the pipe.
4. Disconnect the clip securing the expansion valve to the hydraulic reservoir bracket.
5. Disconnect the inlet and outlet pipes to the suction throttling valve then remove the valve.

Expansion valve—To fit

Fit the expansion valve by reversing the procedure given for its removal noting the following points.

1. Renew 'O' rings where fitted, lubricate all threads and connections with the approved compressor oil.
2. **On early cars**, where the expansion valve is fitted inside the evaporator box, care should be taken not to kink or damage the balance pipe when feeding it through the evaporator box casing. Also, the expansion valve thermal bulb must be strapped tightly to the low pressure outlet pipe.

Section C7

EVAPORATOR, CONDENSER, RECEIVER/DRIER UNIT AND 'FAST-IDLE' SOLENOID

Evaporator box—To remove (see Fig. C31)

1. Discharge the refrigerant (see Section C4).
2. Disconnect the battery.
3. Remove the front seats (see Chapter S).
4. **On standard cars fitted with a centre console**, proceed as described in Operations 5 and 8.
5. Lift back the carpet surrounding the tidy box and console.
6. Remove the three screws securing the tidy box to the transmission tunnel.
7. Remove the six setscrews securing the centre console to the transmission tunnel then withdraw the console sufficiently for the electrical connections to be disconnected then disconnect them.
8. Remove the console.
9. **On cars not fitted with a centre console**, remove the radio as described in Chapter M.
10. Remove the under facia trim panels (see Chapter S).
11. Remove the screws securing the top roll to the instrument board. The screws are situated underneath the protruding edge of the top roll also at each end of the top roll.
12. Remove the screws securing the facia to the instrument board.
13. Remove the setscrews securing the instrument board to its inner and outer mounting brackets.
14. Withdraw the instrument board sufficiently for the wiring to be disconnected then disconnect the wiring and remove the board together with the instruments (see Chapter M).

15. Disconnect the drain pipe at the bottom of the evaporator box.

16. **On early cars**, where the expansion valve is fitted inside the evaporator box (see Fig. C29), disconnect the three pipes leading to the evaporator box. The connections for two of these pipes are situated adjacent to the heater coolant tap, the third connection is situated adjacent to the rubber grommets fitted into the toeboard.

17. **On late cars**, where the expansion valve is fitted inside the engine compartment (see Fig. C30), disconnect the two pipes fitted to the bottom of the evaporator box (see Fig. C31).

18. Remove the screws securing the evaporator box to its two mounting brackets then remove the box.

On early cars, it will be necessary when removing the box, to manoeuvre the refrigeration pipes through the rubber grommets fitted into the toeboard.

Evaporator box—To fit

Fit the evaporator box by reversing the procedure given for its removal.

Evaporator matrix—To remove (see Fig. C29)

1. If the expansion valve is fitted inside the evaporator box, it should be removed as described earlier in this Section.
2. Remove the setscrews securing the evaporator matrix to the evaporator box; remove the matrix.

Chapter C

Evaporator matrix—To fit

Fit the evaporator matrix by reversing the procedure given for its removal noting the following point.

1. If a new evaporator matrix is to be fitted, add sufficient compressor oil to compensate for the amount lost in the old matrix.

Condenser—To remove
(see Fig. C15)

1. Remove the radiator grille, refer to Chapter S.
2. Discharge the refrigerant (see Section C4).
3. Disconnect the two high pressure pipes located at the top of the condenser.
4. Remove the four setscrews securing the condenser to the coachwork; remove the condenser.

Condenser—To fit

Fit the condenser by reversing the procedure given for its removal noting the following point.

1. If a new condenser is to be fitted add sufficient compressor oil to compensate for the amount lost in the old condenser.

Receiver/drier unit—To remove
(see Fig. C15)

1. Discharge the refrigerant (see Section C4).
2. Disconnect the high pressure inlet and outlet pipes and slacken the clip securing the receiver/drier; remove the unit.

Receiver/drier unit—To fit

Fit a new unit by reversing the procedure given for its removal, noting the following point.

1. Use new rubber 'O' rings.
2. Add sufficient compressor oil to compensate for the amount lost in the old receiver/drier unit.

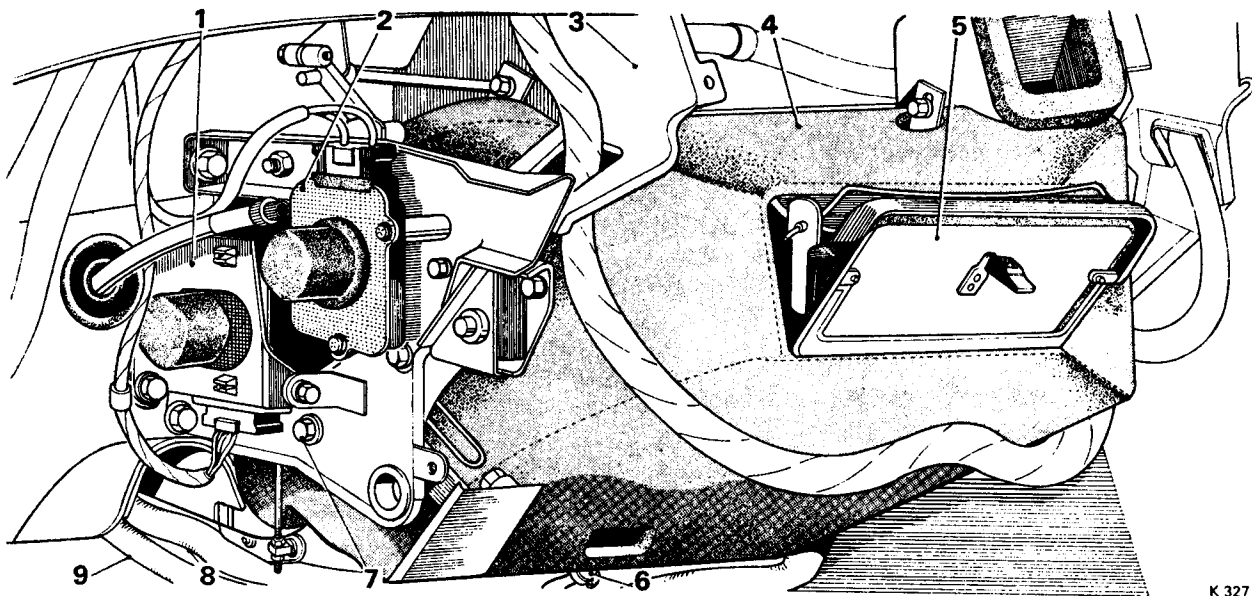

K 327

FIG. C31 POSITION OF THE EVAPORATOR BOX

- | | |
|--|---|
| 1 Lower quantity flap actuator | 6 Evaporator box drain tube |
| 2 Evaporator box change-over flap actuator | 7 Evaporator box mounting screws (4 off) |
| 3 Instrument board mounting bracket | 8 Low pressure pipe (fitted between evaporator box and S.T.V.) |
| 4 Evaporator box | 9 Low pressure pipe (fitted between evaporator box and expansion valve) |
| 5 Outlet flap—Refrigerated/fresh air | |

Fitting of new units

1. Whenever a new unit is fitted a measured quantity of compressor oil should be added to that component to ensure that the oil charge is correct before operating the system.

2. These quantities are as follows.

Evaporator 3 fluid oz. (84 c.c.)

Condenser 1 fluid oz. (28 c.c.)

Receiver 1 fluid oz. (28 c.c.)

3. Compressor oil should be poured into the replacement unit. If a new evaporator is to be fitted, pour the compressor oil into the inlet pipe with the pipe held vertically. This will ensure that the oil drains into the evaporator core.

4. Upon assembly of the refrigeration system, the full process of evacuation and sweeping must be carried out before charging the system.

'Fast-idle' solenoid—To remove
(see Fig. C32)

1. Disconnect the battery.
2. Disconnect the two feed wires at the 'Lucar' terminals.
3. Remove the two bolts securing the solenoid to the baseplate and remove the solenoid.

'Fast-idle' solenoid—To fit

Fit the solenoid by reversing the procedure given for its removal, taking care to connect the solenoid leads to their respective main 'Lucar' connectors.

Vacuum operated actuator—To remove

1. Carefully remove the two flexible pipes from the underside of the actuator unit.
2. Remove the bolts securing the actuator unit to the underside of the baseplate; remove the actuator unit.

Vacuum operated actuator—To fit

Fit the vacuum actuator by reversing the procedure given for its removal.

Note The vacuum actuator is a factory built unit and should not require adjustment.

Vacuum unit—To remove

1. Carefully remove the flexible pipe from the underside of the vacuum unit.
2. Remove the three half nuts from the underside of the bracket.
3. Do not slacken the screws as this may cause a diaphragm leak.

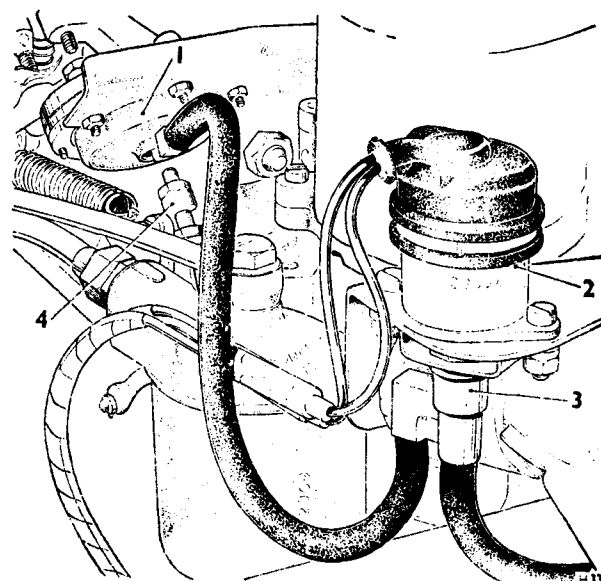

FIG. C32 VACUUM OPERATED FAST-IDLE ARRANGEMENT

- 1 Vacuum unit
- 2 Solenoid
- 3 Vacuum pipe to induction manifold
- 4 Fast-idle adjustment screw

Vacuum unit—To fit

Fit the vacuum unit by reversing the procedure given for its removal.

'Fast-idle'—To set

(see Fig. C32)

1. Prior to setting the 'fast-idle' screw ensure that the carburettor linkage is correctly adjusted (see Chapter K) i.e. the lost motion slots in the twin connecting links must allow the carburettor to move to the 'fast-idle' position without moving the remainder of the throttle linkage.

2. To obtain the correct 'fast-idle' position, run the engine with the gear lever in 'P' or 'N' position to obtain the normal operating temperature and switch on the refrigeration system. 'P' position should be used in preference to 'N' position on cars fitted with a torque converter transmission.

3. Slacken the lock-nut and adjust the screw to give an engine speed of 900 r.p.m. The screw should then be locked in this position.

Section C8

ELECTRICAL ACTUATORS AND FLAPS

Recirculation actuator—To remove

(see Fig. C33)

1. Disconnect the battery.
2. Carefully remove the side trim panel by prising the carpet tacks from behind the piping along the door pillar; the panel can then be removed.
3. Disconnect the 'Lucar' connector from the actuator.
4. Slacken the pinch bolt securing the actuator crank lever to the actuator spindle; remove the lever from the spindle.
5. Unscrew the three 'Phillips' screws securing the actuator to the support bracket; remove the actuator.

Recirculation actuator—To fit

Fit the actuator to its support by reversing the procedure given for its removal.

Recirculation actuator—To adjust

(see Fig. C33)

1. To allow the recirculation actuator to rotate to the closed position, move the upper heating and demister switch to the off position.
2. Slide the actuator lever onto the spindle; do not tighten the pinch bolt.
3. Rotate the actuator lever until the lever and the link rods lie parallel to each other; tighten the pinch bolt.
4. The two nuts on the end of the link rod should then be tightened against the swivel pin until the flap is seated on the lower aperture; the nuts can then be locked together.

5. The upper nuts should be set and locked together so that the spring is compressed to a length of between $\frac{7}{8}$ in. and 1 in. (22,2 mm. and 25,4 mm.).

6. To check for correct operation select the recirculation position.

7. If the flap is seating correctly, the spring should be further compressed by $\frac{1}{8}$ in. to $\frac{1}{4}$ in. (3,17 mm. to 6,35 mm.) as seen by the distance from the swivel pin to the lower locking nuts.

Evaporator box change-over flap actuator— To remove

1. Disconnect the battery.
2. Remove the screws securing the facia into position and remove the facia.
3. Remove the screws securing the top roll to the instrument board. The screws are situated underneath the protruding edge of the top roll also at each end of the top roll.
4. Remove the top roll to reveal the change-over flap actuator.

On left-hand drive cars, this actuator is fitted adjacent to the lower quantity flap actuator (see Fig. C34).

On right-hand drive cars, it is fitted adjacent to the lower temperature flap actuator (see Fig. C11).

5. Disconnect the electrical connections to the actuator.

6. Slacken the pinch bolt securing the actuator crank lever to the actuator spindle. Remove the actuator lever from the spindle.

Chapter C

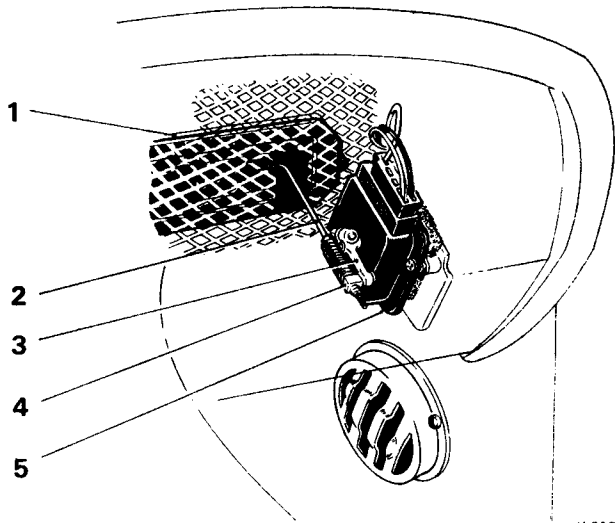

FIG. C33 POSITION OF RECIRCULATION ACTUATOR

- 1 Recirculation flap
- 2 Control rod
- 3 Lever
- 4 Swivel pin
- 5 Actuator

K 295

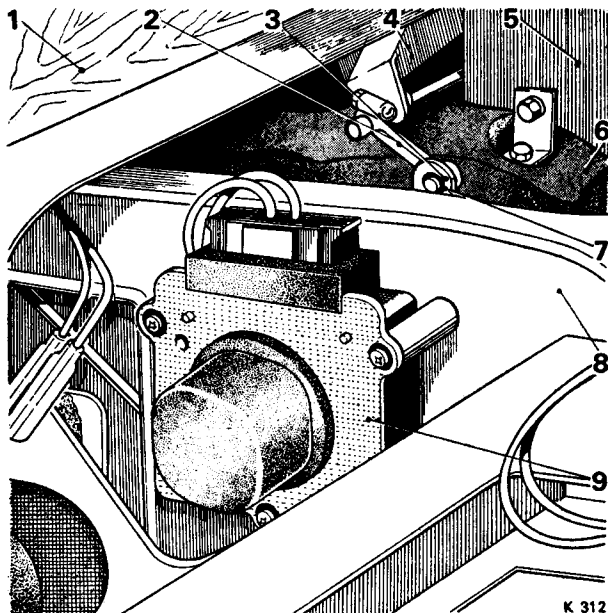

FIG. C34 POSITION OF CHANGE-OVER FLAP ACTUATOR (Left-hand drive cars)

- 1 Wood finisher
- 2 Lever
- 3 Lever
- 4 Bracket
- 5 Duct
- 6 Evaporator
- 7 Retaining ring
- 8 Instrument board mounting bracket
- 9 Actuator

K 312

7. Remove the two 2 B.A. setscrews holding the actuator frame to the main facia panel frame; withdraw the assembly.

8. Unscrew the three 'Phillips' screws securing the actuator to the support bracket; remove the actuator.

**Evaporator box change-over flap actuator—
To fit**

Fit the actuator by reversing the procedure given for its removal.

**Evaporator box change-over flap linkage—
To adjust**

(see Fig. C34)

1. To allow the recirculation actuator to rotate to the closed position, move the upper heating and demister switch to the off position.

2. Rotate the actuator crank lever until the flaps are pressing on their horizontal seats; the flaps are visible through the outlet ducts on the facia. Tighten the pinch bolt.

3. Select a refrigeration position then a heating and demisting position to ensure that the actuator does not stall in either position.

**Suction throttling valve actuator—
To remove**

1. Slacken the pinch bolt securing the actuator crank lever to the actuator spindle; remove the lever.

2. Unscrew the three 'Phillips' screws securing the actuator to the support bracket; remove the actuator.

Suction throttling valve actuator—To fit

Fit the actuator to its support bracket by reversing the procedure given for its removal.

**Suction throttling valve actuator linkage—
To adjust**

(see Fig. C27)

1. Rotate the actuator crank lever on the actuator spindle one full turn to ensure that binding of the linkage does not take place.

2. With the 'UPPER' switch in the fully anti-clockwise position (maximum cooling), rotate the actuator crank lever until the lever and the link rod lie parallel to each other; tighten the pinch bolt.

3. Select a refrigeration position then a heating and demisting position to ensure that the actuator does not stall in either position.

Section C9

REAR REFRIGERATION UNIT

Introduction

On Long Wheelbase cars fitted with a centre division, the refrigeration system detailed in the previous sections is supplemented, by an additional rear refrigeration unit which is dealt with in this Section.

The rear refrigeration unit is supplied with refrigerant by the same compressor and condenser that supplies the front system but employs its own evaporator assembly. This assembly, which is situated in the luggage compartment behind a trim panel, consists of the evaporator, suction throttling valve, expansion valve, twin blower motors and two electrical actuators housed in a metal box (*see Fig. C38*).

Unlike the front system, the air flow through the rear unit is not fully recirculatory, as a small proportion of fresh air is admitted to the evaporator assembly when the rear system is operating. Interior air, drawn into the evaporator box through recirculation intakes in the rear parcel shelf, mixes with the fresh air before passing through the evaporator. The cooled air is delivered into the rear compartment through outlet ducts in the quarter panels.

Servicing

The Servicing procedure detailed in Section C4 is applicable to refrigeration systems incorporating the rear refrigeration unit, except for the following.

Under the heading Refrigeration system - To charge, Operation 3, the weight of refrigerant in the system should be increased to a final weight of between 4.25 lb. and 4.75 lb. (1.93 kg. and 2.15 kg.), after the system has been checked and found to be leak free.

OVERHAUL

Evaporator box assembly—To remove (*see Fig. C35*)

1. Discharge the refrigeration system (*see Section C4*).

2. Disconnect the battery.

3. Remove the rear seat, back rest, cheek pads and the cold air outlet ducts as described later in this Section (*see Outlet ducts - To remove*).

4. Remove the parcel shelf trim panel complete with the rear radio speaker grille and the recirculated air intake grilles.

The parcel shelf trim panel is secured by upholstery clips; a wedge shaped tool will be required for inserting under the clips to prise the panel from the parcel shelf.

5. Remove the six self-tapping screws securing the trim panel in the forward section of the luggage compartment; remove the panel.

6. Slacken the worm drive clips securing the transparent drain tubes and the lower drain hoses to the evaporator box; disconnect the drain tubes and hoses from the box.

7. Disconnect the electrical loom emerging from the left-hand side of the evaporator box.

8. Disconnect the refrigerant inlet and outlet pipes to the evaporator assembly.

9. Peel back the rubber sleeve connections on each side of the evaporator box and disconnect the flexible air delivery tubes from the evaporator outlet ducts.

10. On early cars, remove the two $\frac{7}{16}$ in. A/F nuts securing each of the two hinge rod support brackets of the luggage compartment cover; remove the brackets from the bolts.

11. Remove the fresh air intake filter as described later in this Section (*see Fresh air intake filter - To remove*).

12. Remove the remaining twelve self-tapping screws securing the clamping plate and the upper flange of the fresh air transfer duct to the car body. Remove the clamping plate and tuck the upper flange of the duct down into the intake so that it is below the lip of the body intake aperture.

Chapter C

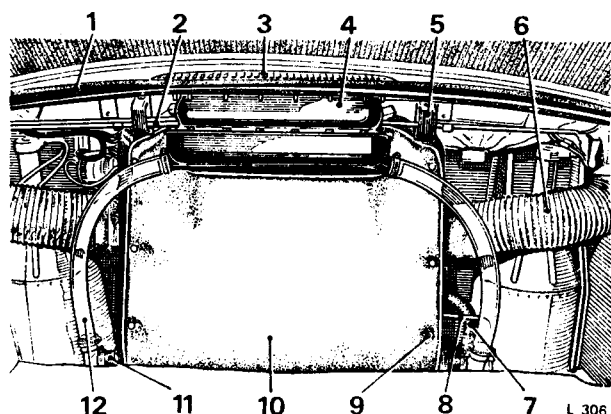

FIG. C35 POSITION OF THE EVAPORATOR BOX ASSEMBLY

- 1 Luggage compartment rubber seal
- 2 Hinge torque rods
- 3 Fresh air intake grille
- 4 Fresh air transfer duct
- 5 Hinge rods support bracket (2 off—if fitted)
- 6 Flexible delivery duct (2 off)
- 7 Suction line (outlet)
- 8 Liquid line (inlet)
- 9 Press-stud fastener (8 off)
- 10 Evaporator box assembly
- 11 Lower drain hose (2 off)
- 12 Transparent drain tube (2 off)

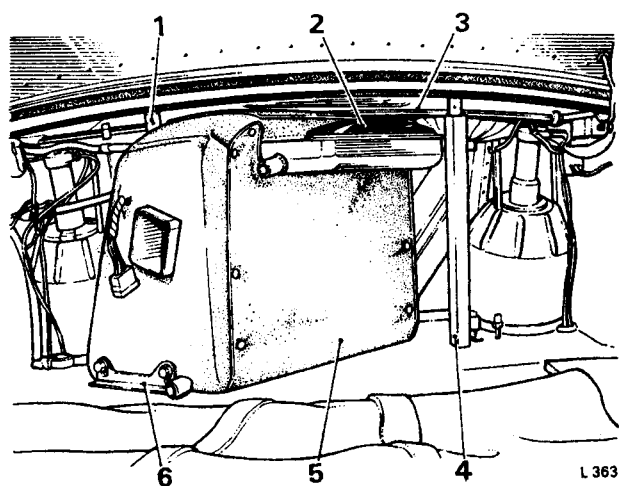

FIG. C36 SHOWING THE WOODEN BLOCK IN POSITION

- 1 Trim panel upper attachment bracket
- 2 Fresh air transfer duct (upper flange of duct shown tucked down into intake)
- 3 Luggage compartment lid hinge rods
- 4 Wooden block
- 5 Evaporator box assembly
- 6 Angled mounting bracket

13. Remove the six self-tapping screws from around each recirculated air intake aperture in the parcel shelf.

14. Remove the three self-tapping screws securing the angled mounting bracket on each side of the evaporator box to the floor of the luggage compartment. Slacken the two $\frac{1}{2}$ in. A/F setscrews securing each mounting bracket to the evaporator box and remove the wooden packing strip from under each bracket.

15. Insert a block of wood, approximately 19 in. (48 cm.) long and 3 in. \times 2 in. (8 cm. \times 5 cm.) thick, between the floor of the luggage compartment and the lid hinge rods; position the block as shown in Figure C36.

16. Carefully remove the evaporator box assembly from the luggage compartment, turning it side-ways slightly during removal to avoid fouling the trim panel upper attachment brackets.

Evaporator box assembly—To fit

To fit the evaporator box reverse the procedure given for removal noting the following points.

1. Before fitting the evaporator box assembly into the luggage compartment, check the condition of the recirculated air intake seals on the underside of the rear parcel shelf; renew if necessary (*see Section C1, Heater matrix - To fit, Operation 2*).

2. Secure the evaporator box assembly into position in the following sequence.

3. Fit the six self-tapping screws around each recirculated air intake aperture sufficiently to just locate them in their holes in the evaporator box.

4. With the setscrews securing the angled mounting brackets to the evaporator box slackened off, fit the wooden packing strip under each mounting bracket and secure them to the floor of the luggage compartment with the self-tapping screws.

5. Lever the evaporator box assembly upward until the top of the box contacts the recirculated air intake seals. With the box still in this position, tighten the six self-tapping screws around each recirculated air intake in the rear parcel shelf.

6. Finally tighten the two $\frac{1}{2}$ in. A/F setscrews securing each angled mounting bracket to the evaporator box assembly.

Evaporator matrix—To remove (*see Fig. C38*)

1. Discharge the refrigeration system (*see Section C4*).

2. Disconnect the battery.

3. Remove the evaporator box as described earlier in this Section (*see Evaporator box assembly - To remove*).

4. Remove the two $\frac{1}{2}$ in. A/F setscrews securing each mounting bracket to the evaporator box.

5. Unclip the press studs securing the rear cover flap on the evaporator box insulating jacket; starting at the upper rear edge, carefully remove the insulating jacket from the evaporator box.

6. Remove the evaporator box rear cover as described later in this Section (see *Suction throttling valve - To remove, Operations 8 and 9*).

7. Remove the six self-tapping screws securing each side patch plate to the evaporator box. Also, remove the upper rear setscrew securing the evaporator and blower motor mounting assembly to each side of the evaporator box; remove the side patch plates.

8. Remove the expansion valve as described later in this Section (see *Expansion valve - To remove, Operations 4 to 7 inclusive*).

9. Disconnect the outlet pipe from the suction throttling valve.

10. Press the square grommet from its aperture in the right-hand side of evaporator box; remove the pipe grommet and the two refrigerant circulation pipes.

11. Disconnect the electrical leads to the suction throttling valve actuator and the leads to the blower motors.

12. Remove the remaining three setscrews on each side of the evaporator box securing the evaporator and blower motor mounting assembly; remove the assembly from the evaporator box.

13. Disconnect the evaporator outlet pipe.

14. Remove the eight $\frac{7}{16}$ in. A/F setscrews securing the evaporator matrix to the mounting assembly; slide the matrix out of the mounting assembly.

Evaporator matrix—To fit

To fit the evaporator matrix reverse the procedure given for removal noting the following points.

1. Ensure that the blower duct to evaporator box seals are positioned correctly.

2. Ensure that the anti-vibration strips are in position between the front and rear lower edges of the evaporator matrix and the evaporator mounting assembly, particularly if a new matrix is to be fitted.

3. If a new matrix is to be fitted, before connecting the refrigerant inlet and outlet pipes, pour sufficient fresh compressor oil into the new matrix to compensate for the amount lost in the old matrix. To determine this amount drain all the oil from the old matrix and measure carefully, then add an equivalent amount of fresh oil to the new matrix.

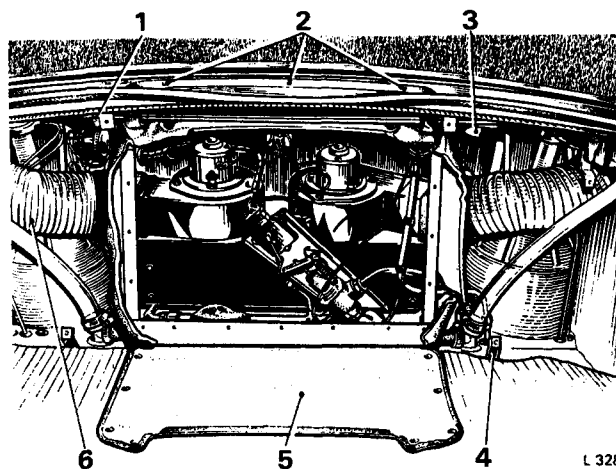

FIG. C37 EVAPORATOR BOX WITH REAR COVER REMOVED

- 1 Rear seat backrest securing screw (2 off)
- 2 Locating pegs for fresh air intake grille
- 3 Radio speaker
- 4 Trim panel attachment bracket
- 5 Insulating jacket flap
- 6 Flexible delivery duct (2 off)

Note. The quantities of compressor oil shown on Page C39 - Fitting of new units - Operation 2, are for guidance only and the amount of fresh oil to be added to the new component should be equal to the amount of oil which can be drained from the old unit.

Suction throttling valve—To remove (see Fig. C38)

1. Discharge the refrigeration system (see Section C4).

2. Disconnect the battery.

3. Remove the six 'Philips' screws securing the carpeted trim panel in the forward section of the luggage compartment; remove the panel.

4. Slacken the worm drive clips securing the upper ends of the transparent drain tubes to the evaporator box rear cover; detach both drain tubes from the cover (see Fig. C35).

5. Remove the fresh air intake grille and filter as described later in this Section (see *Fresh air intake filter - To remove*).

6. Remove the remaining twelve self-tapping screws securing the clamp and upper flange of the fresh air transfer duct to the car body (see Fig. C43); remove the clamp and tuck the upper flange of the transfer duct down, so that it is below the lip of the intake aperture.

Chapter C

7. Unfasten the eight press studs securing the rear flap of the evaporator box insulating jacket.

8. Remove the fifteen self-tapping screws securing the evaporator box rear cover; note that the upper edge of the cover is still secured to the evaporator box by three clips on the inside of the cover (see Fig. C40, item 2).

9. Pull the evaporator box rear cover downwards to detach the three clips and withdraw the cover sufficiently to enable the electrical leads to the fresh air flap actuator to be disconnected; disconnect the leads and remove the cover together with the fresh air transfer duct.

10. Disconnect the inlet and outlet pipes from the suction throttling valve.

11. Disconnect the equalising pipe from the suction throttling valve.

12. Disconnect the electrical leads to the suction throttling valve actuator.

13. Remove the three 2 B.A. setscrews securing the suction throttling valve and actuator mounting bracket to the evaporator and blower mounting assembly; remove the mounting bracket.

Note. It is necessary to remove the actuator mounting bracket in order to gain access to the suction throttling valve securing bolts.

14. Slacken the pinch bolt securing the actuator crank lever to the actuator spindle.

15. Remove the two special setscrews securing the suction throttling valve to its mounting bracket; remove the valve.

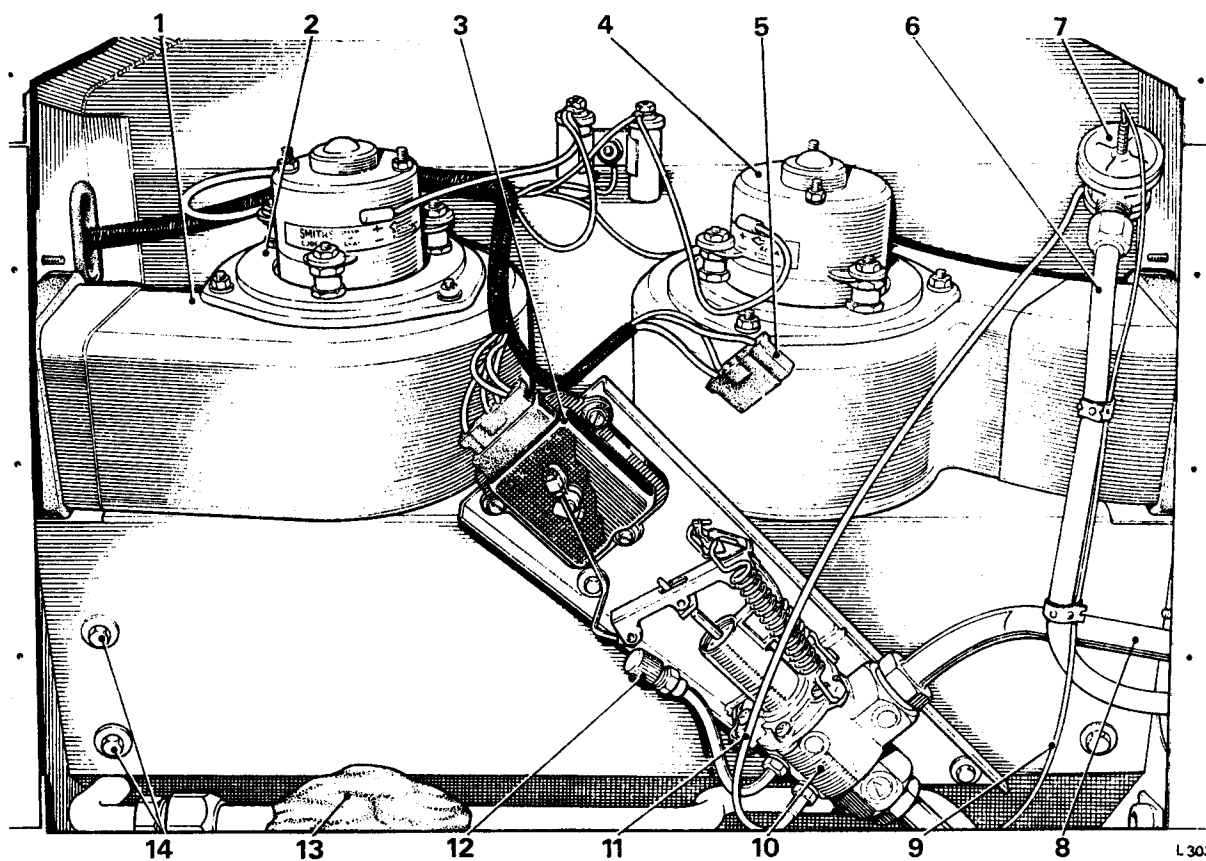

FIG. C38 EVAPORATOR BOX COMPONENTS

- | | |
|---|---|
| 1 Blower housing/outlet duct assembly (2 off) | 8 Suction line (outlet) |
| 2 Blower motor mounting plate (2 off) | 9 Capillary tube |
| 3 Suction throttling valve actuator | 10 Suction throttling valve |
| 4 Blower motor (2 off) | 11 Equaliser pipe |
| 5 Fresh air flap actuator connector block | 12 Charging pipe cap |
| 6 Liquid line (inlet) | 13 Thermal bulb insulation |
| 7 Expansion valve | 14 Evaporator matrix securing setscrews (8 off) |

Suction throttling valve—To dismantle (see Fig. C26)

Dismantle the suction throttling valve as described in Section C6.

Suction throttling valve—To inspect

Inspect the suction throttling valve as described in Section C6.

Suction throttling valve—To assemble

Assemble the valve as described in Section C6 (see *Suction throttling valve – To assemble, Operations 1 to 10 inclusive*), noting that the valve must be adjusted after it is fitted to the car.

Suction throttling valve—To fit

To fit the suction throttling valve reverse the procedure given for removal noting the following points.

1. The inlet and outlet pipes should be loosely connected to the suction throttling valve before the mounting bracket is secured to the evaporator; tighten the pipe connections after securing the mounting bracket.
2. Fit new sealing rings and lubricate all threads and connections with the approved compressor oil.
3. Check the condition of the cover seal and renew if necessary (see *Section C1, Heater matrix – To fit, Operation 2*).
4. Before the evaporator box rear cover is fitted the S.T. valve and valve linkage must be adjusted and the valve pressure checked and adjusted as necessary.

Suction throttling valve—To adjust

1. Evacuate, sweep and charge the system as described in Section C4, noting also the point mentioned under Servicing earlier in this Section.
2. Adjust the suction throttling valve as described in Section C6. *Suction throttling valve – To adjust, Operations 2 to 5 inclusive*.
3. Secure the crank lever to the actuator spindle as described later in this Section (see *Suction throttling valve actuator linkage – To adjust, Operations 4 to 11 inclusive*).
4. After adjusting the valve linkage, adjust the valve pressure as follows.

Suction throttling valve pressure—To adjust

1. Remove the 'Schrader' valve cap from the charging pipe on the suction throttling valve (see *Fig. C38, item 2*).
2. Fit the 'Schrader' valve adaptor (RH 7937) to a flexible hose and gauge, then connect the adaptor to the suction throttling valve charging pipe.

3. Purge the air from the hose by slackening the connection on the pressure gauge for a few seconds.

4. Start and run the engine at a speed of between approximately 1 000 r.p.m. and 1 250 r.p.m.: select maximum speed on the rear refrigeration blower switch.

5. Turn the rear refrigeration temperature switch fully anti-clockwise and then back to the 'off' position (so that the actuator crank makes a full turn). Repeat this operation ten times to normalise the suction throttling valve diaphragm.

6. Allow the system to operate for a further five minutes until pressure in the system becomes stable.

7. Slowly increase the engine speed until the gauge pressure ceases to fall and the suction throttling valve can be seen to control the pressure by the slight hunting of the gauge needle.

The stabilised suction throttling valve pressure should be between 29 lb/sq. in. and 30 lb/sq. in. (2.03 kg/sq. cm. to 2.11 kg/sq. cm.) gauge reading.

8. If it is necessary to adjust the suction throttling valve pressure, rotate the pressure adjusting nut (see *Fig. C28*), using the adjusting tool (RH 7934); clockwise rotation increases the pressure, anti-clockwise rotation decreases the pressure.

9. Remove the 'Schrader' valve adaptor (RH 7937) from the suction throttling valve charging pipe.

10. Fit the 'Schrader' valve cap to the suction throttling valve charging pipe.

11. Fit the evaporator box rear cover, trim panel etc. by reversing the procedure given for removal.

Note. Ensure that the electrical leads to the actuators are not inadvertently disconnected while fitting the evaporator box rear cover.

Suction throttling valve pressures

Switch Position	Approximate Gauge Pressures
1st	52lb/sq. in. to 54lb/sq. in. (3.66 kg/sq. cm. to 3.79 kg/sq. cm.)
2nd	44lb/sq. in. to 46lb/sq. in. (3.09 kg/sq. cm. to 3.23 kg/sq. cm.)
3rd	33lb/sq. in. to 35lb/sq. in. (2.32 kg/sq. cm. to 2.46 kg/sq. cm.)
4th	29lb/sq. in. to 30lb/sq. in. (2.03 kg/sq. cm. to 2.11 kg/sq. cm.)

Chapter C

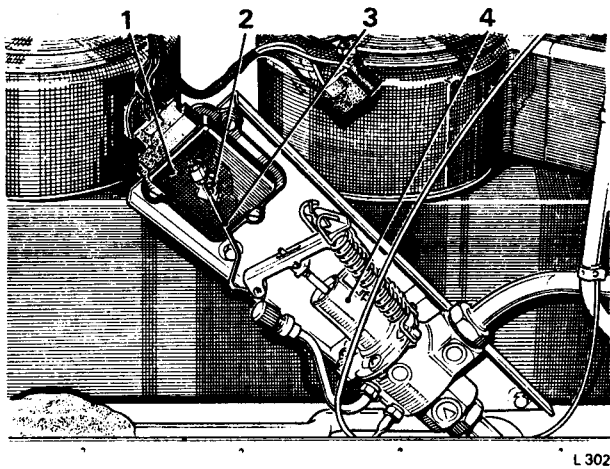

FIG. C39 SUCTION THROTTLING VALVE ACTUATOR SETTING

- 1 Actuator
- 2 Crank lever
- 3 Link rod
- 4 Suction throttling valve

Expansion valve—To remove (see Fig. C38)

1. Discharge the refrigeration system (see Section C4).
2. Disconnect the battery.
3. Remove the carpeted trim panel in the forward section of the luggage compartment and the rear cover of the evaporator box as described earlier in this Section (see *Suction throttling valve – To remove, Operations 3 to 9 inclusive*).
4. Disconnect the equaliser pipe from the suction throttling valve.
5. Remove the two nylon straps securing the capillary tube to the inlet pipe.
6. Remove the putty insulation surrounding the thermal bulb on the suction throttling valve inlet pipe (see Fig. C38); slacken the clip securing the thermal bulb to the inlet pipe, then slide the bulb clear of the pipe.
7. Disconnect the inlet and outlet pipes to the expansion valve; remove the valve.

IMPORTANT. Do not attempt to alter the factory setting of the expansion valve. If the valve is faulty fit a new unit.

Expansion valve—To fit

To fit the expansion valve reverse the procedure given for removal noting the following points.

1. Before fitting the expansion valve, check the gauze filter in the inlet bore and clean if necessary.
2. Fit new sealing rings, lubricate all threads and connections with the approved compressor oil.

3. Ensure that the thermal bulb on the capillary tube is firmly secured to the suction throttling valve inlet pipe.

Suction throttling valve actuator—To remove

1. Disconnect the battery.
2. Remove the carpeted trim panel in the forward section of the luggage compartment and the rear cover of the evaporator box as described earlier in this Section (see *Suction throttling valve – To remove, Operations 3 to 9 inclusive*).
3. Disconnect the electrical leads from the actuator terminals.
4. Slacken the pinch bolt securing the actuator crank lever to the actuator spindle; remove the lever.
5. Remove the three cheeseheaded screws securing the actuator to the support bracket; remove the actuator noting the spacing washers between the actuator and the support bracket.

Suction throttling valve actuator—To fit

To fit the actuator reverse the procedure given for removal noting that before the rear cover of the evaporator box is fitted, the actuator linkage must be adjusted as follows.

Suction throttling valve actuator linkage—To adjust (see Fig. C39)

1. With the actuator crank lever loosely mounted on the actuator spindle, rotate the lever about the spindle to ensure that the linkage does not bind.
2. With the throttling valve fully open, adjust the 5 B.A. lock-nuts on the link rod until the link rod and the crank lever lie parallel to each other as shown in Figure C39; tighten the 5 B.A. lock-nuts on the link rod.
3. Rotate the crank lever a full turn about the actuator spindle to ensure that the S. T. V. spindle does not bottom in the valve and that binding or distortion does not take place.

If bottoming does occur, check that the suction throttling valve is set correctly and adjust as necessary (see *Suction throttling valve – To adjust*).

4. Connect the negative lead of a 12 volt battery to the negative tag on the actuator (*i.e. the tag adjacent to number 1 tag*).
5. Connect the positive lead of the same battery to the number 1 tag and allow the actuator spindle to rotate; this will give the maximum cooling position.
6. Disconnect the temporary battery leads from the actuator.

7. With the actuator lever and the link rod parallel and the suction throttling valve fully open, tighten the actuator lever pinch bolt (see Fig. C39).
8. Connect the electrical leads to the S. T. V. actuator.
9. Position the electrical connections to the fresh air flap actuator (see Fig. C38, item 5) such that they cannot cause an electrical 'short' when the battery leads are connected and the refrigeration switch operated.
10. Connect the battery leads.
11. Switch on the ignition.
12. Select in turn, each position on the rear refrigeration temperature switch and check that the actuator operates and does not stall.

Fresh air flap—To remove (see Fig. C40)

The fresh air flap is mounted on the inner face of the evaporator box rear cover; to remove the flap proceed as follows.

1. Disconnect the battery.
2. Remove the trim panel in the luggage compartment and the rear cover of the evaporator box as described earlier in this Section (see *Suction throttling valve - To remove, Operations 3 to 9 inclusive*).
3. (a) **Cars prior to Car Serial Number LRX 8146** - Release the 5 B.A. lock-nuts on the flap control rod and disconnect the rod from the actuator crank lever (see Fig. C41).
- (b) **Cars after and including Car Serial Number LRX 8146** - Remove the 2 B.A. lock-nut securing the two-stud 'Metalastik' adjuster to the crank lever swivel block; disconnect the adjuster from the block (see Fig. C42).
4. Remove the two 3 B.A. setscrews securing each of the flap hinge brackets to the rear cover; remove the flap complete with the hinge brackets and distance pieces.

Fresh air flap—To fit

To fit the flap reverse the procedure given for removal noting the following points.

1. If the flap seal is in poor condition, renew the seal (see *Section C1 Heater matrix - To fit, Operation 2*).
2. Before fitting the rear cover to the evaporator box set the flap control rod as described later in this Section (see *Fresh air flap actuator - To fit and set*).

Fresh air flap actuator—To remove (see Figs. C41 and C42)

The fresh air flap actuator is mounted on the inner face of the evaporator box rear cover; to remove the actuator proceed as follows.

1. Disconnect the battery.

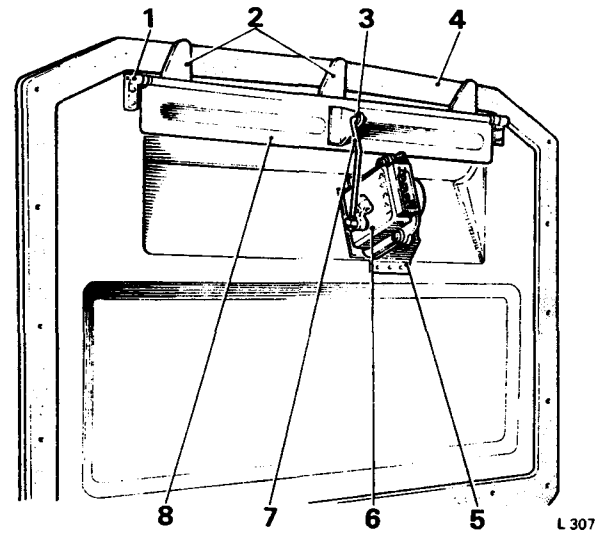

FIG. C40 POSITION OF FRESH AIR FLAP AND ACTUATOR ON THE REAR COVER

- 1 Flap hinge bracket (2 off)
- 2 Cover retaining lugs (3 off)
- 3 Nylon bush
- 4 Rubber seal
- 5 Actuator mounting bracket
- 6 Actuator
- 7 Link rod
- 8 Fresh air flap

2. Remove the trim panel in the luggage compartment and the rear cover of the evaporator box as described earlier in this Section (see *Suction throttling valve - To remove, Operations 3 to 9 inclusive*).
3. Slacken the pinch bolt securing the actuator crank lever to the actuator spindle; remove the crank lever and the spacing washer from the spindle.
4. (a) **Cars prior to Car Serial Number LRX 8146** - Remove the three screws, nuts and washers securing the actuator to the support bracket (see Fig. C41); remove the actuator noting the spacing washers between the actuator and the support bracket.

(b) **Cars after and including Car Serial Number LRX 8146** - Remove the 2 B.A. nuts and washers securing the actuator to the three 'Metalastik' mounts (see Fig. C42); remove the actuator.

Fresh air flap actuator—To fit and set

To fit the fresh air flap actuator reverse the procedure given for removal noting that before the evaporator box rear cover is fitted, the actuator linkage must be set as follows.

1. Connect the negative lead of a 12 volt battery to the negative tag of the actuator (i.e. the tag adjacent to the number 1 tag).
2. Connect the positive lead of the same battery to the number 5 tag and allow the actuator spindle to rotate to the closed position.

Chapter C

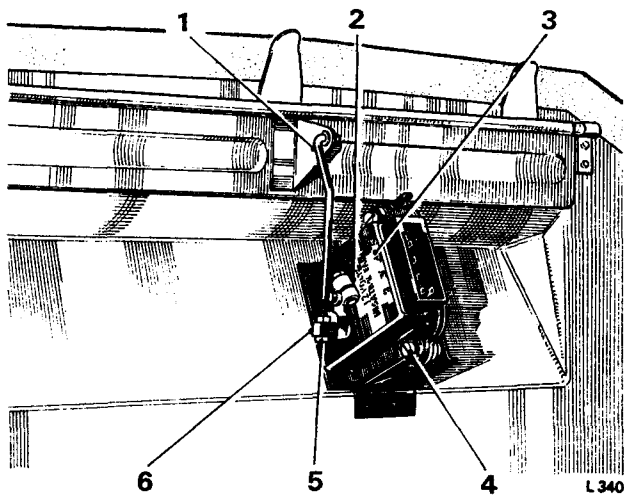

**FIG. C41 FRESH AIR FLAP ACTUATOR SETTING
—EARLY CARS**

- 1 Link rod
- 2 Crank lever
- 3 Actuator
- 4 Actuator securing screw (3 off)
- 5 Lock-nut (2 off)
- 6 Swivel block

3. With the actuator crank lever mounted loosely on the actuator spindle, rotate the lever to ensure that the linkage does not bind.

4. (a) Cars prior to Car Serial Number LRX 8146 – Hold the fresh air flap firmly onto its seat then adjust the 5 B.A. lock-nuts on the link rod until the link rod and the crank lever lie parallel to each other as shown in Figure C41; tighten the 5 B.A. lock-nuts.

(b) Cars after and including Car Serial Number LRX 8146 – Slacken the 2 B.A. lock-nuts on the two-stud 'Metalastik' adjuster attached to the link rod. Hold the fresh air flap firmly onto its seat then screw the adjuster in or out of the link rod hexagonal extension, as required, until the link rod and the 'Metalastik' adjuster lie parallel to the crank lever as shown in Figure C42; tighten the 2 B.A. lock-nuts.

5. Rotate the crank lever a full turn on the actuator spindle to ensure that there is no binding or distortion.

6. With the fresh air flap held firmly onto its seat, tighten the crank lever pinch bolt.

7. Energise in turn the number 1 tag (flap open) and then the number 5 tag (flap closed) of the actuator with the positive lead of the 12 volt battery. Check that the flap opens and closes correctly when the appropriate tag is energised and that the actuator does not stall in either position.

8. Disconnect the temporary battery leads from the actuator.

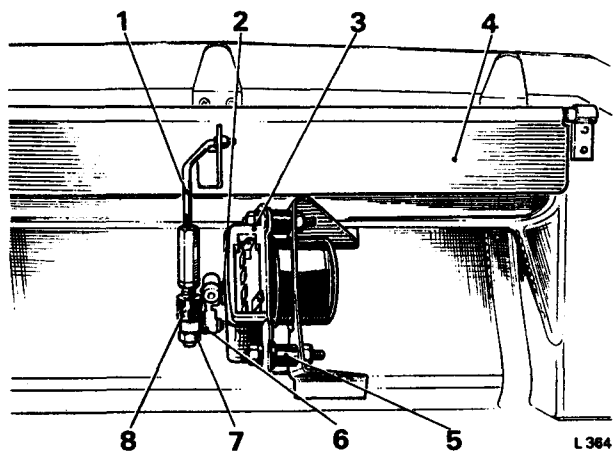

**FIG. C42 FRESH AIR FLAP ACTUATOR SETTING
—LATE CARS**

- 1 Link rod
- 2 Spacing washer
- 3 Actuator
- 4 Fresh air flap
- 5 Metalastic mount (3 off)
- 6 Crank lever and swivel block assembly
- 7 Lock-nut
- 8 Metalastic adjuster

**Fresh air intake filter—To remove
(see Fig. C43)**

The fresh air intake filter is situated below the intake grille in the rear decking panel (see Fig. C43); to remove the foam filter element proceed as follows.

- 1. Raise the luggage compartment lid.
- 2. Detach the luggage lid rubber seal from the rear flange of the fresh air intake grille.

Note. Care must be taken when carrying out this operation to avoid damage to the rubber seal and surrounding paintwork.

- 3. Remove the three 2 B.A. setscrews securing the intake grille to the car body.
- 4. Raise the rear flange of the intake grille sufficiently to just clear the luggage lid rubber seal then remove the intake grille from the three locating pegs securing the forward edge of the grille to the car body (see Fig. C37).

5. Raise the outer ends of the foam filter element and remove the two screws securing the lower filter mesh to which the foam element is attached by adhesive; remove the filter mesh and foam element.

6. Detach the foam filter element from the filter mesh and remove any surplus adhesive from the mesh using 'Bostik' cleaner 6001.

Fresh air intake filter—To fit

To fit the foam filter element reverse the procedure given for removal noting the following points.

1. The new foam element should be fixed to the lower intake mesh using 'Bostik' adhesive 1261.
2. Before fitting the intake grille onto the three locating pegs ensure that the three rubber grommets are in position in the front flange of the grille.
3. To fix the luggage lid rubber seal, first clean the bonding area of the seal and its mating metal surface with 'Bostik' cleaner 6001. Allow the cleaner to dry for one hour then apply 'Boscolite' primer 9252 to the metal surface only. Allow the primer to dry for one hour then apply 'Boscoprene' cement 2402 parts 1 and 2, to the rubber seal and its mating metal surface. Allow the cement to partially dry for between five and fifteen minutes then fix the rubber seal firmly into its original position. Do not close the lid of the luggage compartment for twelve hours.

If the rubber seal is damaged a new seal must be fitted.

Fresh air transfer duct—To remove

(see Fig. C43)

1. Disconnect the battery.
2. Remove the carpeted trim panel in the forward section of the luggage compartment and the evaporator box rear cover as described earlier in this Section (see *Suction throttling valve - To remove, Operations 3 to 9 inclusive*).
3. Slacken the screws on the evaporator box rear cover securing the two latches to the forward edge of the transfer duct lower clamp; rotate the latches clear of the clamp and transfer duct.
4. Remove the ten 2 B.A. setscrews securing the lower clamp and the transfer duct to the rear cover (see Fig. C43); remove the transfer duct and clamp.

Fresh air transfer duct—To fit

To fit the transfer duct reverse the procedure given for removal noting the following point.

1. Check the condition of the transfer duct before fitting and renew if necessary.

Flexible delivery ducts—To remove

(see Fig. C38)

To remove a delivery duct proceed as follows, noting that the removal procedure is the same for both ducts.

1. Remove the six screws securing the trim panel in the forward section of the luggage compartment; remove the panel.
2. Peel back the rubber sleeve connections on the evaporator end of the delivery duct and detach the duct from the evaporator outlet duct.

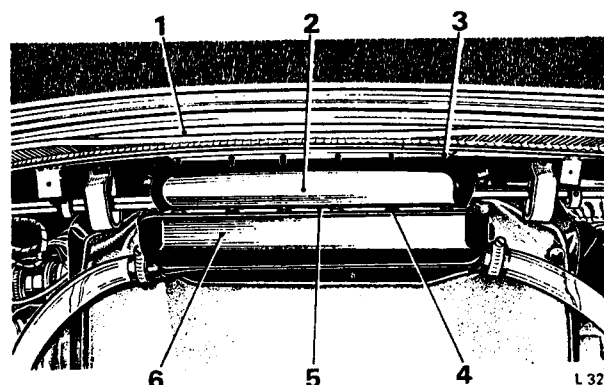

FIG. C43 FRESH AIR INTAKE AND TRANSFER DUCT

- 1 Recess for intake filter (grille removed)
- 2 Transfer duct
- 3 Screw securing duct to car body (14 off)
- 4 Screw securing duct to cover (10 off)
- 5 Duct lower clamping plate
- 6 Rear cover intake flange

3. Slacken the worm-drive clip securing the outlet end of the delivery duct to the car body duct: remove the delivery duct.

Flexible delivery ducts—To fit

To fit the delivery ducts reverse the procedure given for removal noting the following points.

1. Check the condition of each duct before fitting and renew if necessary. Minor damage to a duct could be temporary repaired using 'Gosherous' tape.
2. The rubber sleeve connections are attached to the delivery ducts with 'Bostik' adhesive 772. Adhesive should not be used when fitting the rubber sleeve connections onto the evaporator box outlet ducts.

Outlet ducts—To remove

To remove an outlet duct proceed as follows noting that the removal procedure is the same for both ducts.

1. Remove the rear seat cushion (refer to Chapter S - Body).
2. Remove the six screws securing the forward trim panel in the luggage compartment; remove the trim panel.
3. Remove the two 'Philips' screws securing the upper corners of the rear seat back rest to the car body.

The screws are located in the front wall of the luggage compartment one each side of the evaporator assembly. The position of the left-hand screw is shown in Figure C37; the right-hand screw is hidden by the radio speaker.

Chapter C

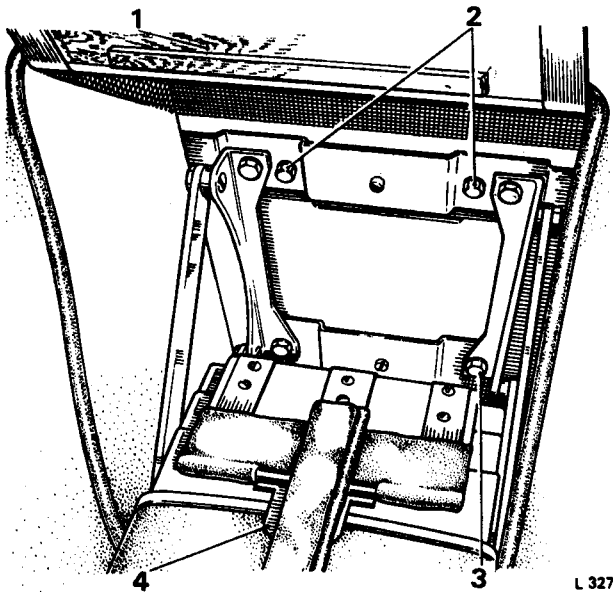

FIG. C44 POSITION OF THE REAR SEAT BACKREST SECURING SETSCREWS

- 1 Trim pad
- 2 Backrest securing setscrews
- 3 Armrest mechanism securing setscrews (4 off)
- 4 Spring flap

4. Remove the two screws situated one in each lower corner of the rear seat back rest in the rear compartment.

5. Lower the rear seat centre arm rest then push the top of the arm rest trim pad inwards as far as possible. Manipulate the lower part of the trim pad until the arm rest mechanism flap is felt to clear the bracket attached to the back of the trim pad. Lift the trim pad upwards to expose the arm rest mechanism.

6. Remove the two $\frac{7}{16}$ in. A/F setscrews and washers securing the rear seat back rest to the car body (see Fig. C44).

7. Remove the rear seat back rest from the car.

8. Carefully detach the rear edge of the rear cheek pad trim from the car body. Fold the trim forward to expose the three screws securing the lower part of the cheek pad to the body; remove the screws. Slide the cheek pad forward until the slotted upper bracket attached to the back of the cheek pad can be detached from the locating screw secured in the body quarter panel. Remove the cheek pad noting that the rear edge of the pad is slotted to accommodate the rear parcel shelf trim panel.

9. Remove the screw securing the lower fixing bracket on the outlet duct to the car body.

10. Grasp the front end of the outlet duct and pull firmly downwards until the slotted upper fixing bracket attached to the back of the duct is felt to clear the locating screw secured to the car body; remove the duct noting that the rear end of the duct is a close fit on the flanged outlet in the rear parcel shelf.

Outlet ducts—To fit

To fit the outlet ducts reverse the procedure given for removal noting the following points.

1. The cheek pad trim should be fixed to the car body using 'Dunlop' upholstery solution L107 or its equivalent.

2. When fitting the rear seat back rest do not tighten the two $\frac{7}{16}$ in. A/F setscrews until the self-tapping screws securing the upper and lower corners are located in their original holes, then tighten all the screws.

Blower motors—To remove (see Fig. C38)

To remove a blower motor proceed as follows, noting that the removal procedure is the same for both motors.

1. Disconnect the battery.

2. Remove the forward trim panel in the luggage compartment and the evaporator box rear cover as described earlier in this Section (see *Suction throttling valve - To remove, Operations 3 to 9 inclusive*).

3. Disconnect the electrical leads to the blower motor.

4. Remove the three 2 B.A. nuts and washers securing the blower motor and mounting bracket to its blower housing; lift the blower motor, complete with fan and mounting bracket, out of its housing and out of the evaporator box.

5. Slacken the 'Allen' grub screw securing the fan to the blower motor output shaft; remove the fan.

6. Remove the rubber seal from the blower motor mounting bracket.

7. Separate the blower motor from its mounting bracket by removing the $\frac{7}{16}$ in. A/F nuts and washers from each end of the three 'Metalastik' mounts.

Blower motors—To fit

To fit the blower motors reverse the procedure given for removal noting the following points.

1. Ensure that the three bonded rubber mounts on each blower motor are in good condition; renew if necessary.

2. Fit new rubber seals to the blower motor mounting plate.

3. When fitting the fan to the blower motor, position the fan on the output shaft so that there is approximately $\frac{3}{8}$ in. (9,25 mm.) between the fan and the lower edge of the mounting plate, then tighten the 'Allen' grub screw.

4. Ensure that the electrical leads to the blower motors are fitted correctly; the yellow/green lead should be connected to the terminal marked \pm on the blower motor casing (see Fig. C38), i.e. the blower fan should rotate anti-clockwise when viewed on the end of the motor output shaft.

Blower motor switch—To remove and fit

Refer to Chapter M – The Electrical Section.

Refrigeration control switch—To remove and fit

Refer to Chapter M – The Electrical Section.

MAINTENANCE

Every 12 months the following maintenance should be carried out.

1. Clean any debris (i.e. leaves, dead insects, etc.) from the surfaces of the condenser matrix by reverse flushing with a hose.

2. Check that the fresh air intake filter is free from obstruction; renew the foam element if necessary (see Section C9, *Fresh air intake filter – To remove*).

The following operations should only be carried out by an experienced refrigeration engineer.

3. Check the functioning of the system; if necessary charge with refrigerant.

4. Check for leaks if loss of refrigerant is apparent.

5. Visually check the compressor for oil leakage; if oil leakage is apparent, check the compressor oil level and top-up if necessary (see Section C4, *Oil level – To check*).

In the event of a major oil loss check and repair before topping-up.

Section C10

FAULT DIAGNOSIS

SYMPTOM	POSSIBLE CAUSE	ACTION
1. Insufficient air flow from air conditioning outlets	1. (a) *Fault in blower motors	1. (a) *Check blower motors for correct operation (see Chapter M)
2. Refrigeration system inoperative	2. (a) System low or empty of refrigerant (b) Compressor clutch slipping (c) Compressor clutch inoperative. No voltage at clutch coil (d) Compressor belt slipping (e) Blockage in system	2. (a) Leak test, repair, evacuate and charge the system (see Section C4 and also C9 if rear unit is fitted) (b) Fit new clutch plate and hub assembly (see Section C5) (c) Check circuit for continuity and repair if necessary (see wiring diagram in Chapter M) (d) Adjust or renew belts (see Section C5) (e) Check filters on compressor, *expansion valve and *suction throttling valve (see Sections C5, C6 and C9)
3. Insufficient cooling of air flowing from air conditioning outlets	3. (a) *Suction throttling valve incorrectly adjusted, evaporator pressure higher than 30 lb/sq. in. (2,11 kg/sq. cm.) maximum cooling setting (b) *Suction throttling valve stuck in closed position, evaporator pressure will not pull down to 30lb/sq. in. (2,11 kg/sq. cm.) (c) *Suction throttling valve actuator sticking or seized and not adjusting valve positions (d) *Expansion valve thermal bulb and capillary discharged, causing valve to close (e) *Expansion valve stuck fully open allowing too much refrigerant through to evaporator (f) *Expansion valve inlet filter clogged restricting flow of refrigerant to evaporator (g) Restriction in receiver/drier unit (h) Condenser air flow reduced by insects, leaves, etc. This is indicated by high head pressure causing safety valve on compressor to blow off	3. (a) Adjust suction throttling valve (see Section C6 - front valve or Section C9 - rear valve). (b) Repair or renew suction throttling valve (see Section C6 - front valve or Section C9 - rear valve) (c) Fit new actuator (see Section C8 - front actuator or Section C9 - rear actuator) (d) Renew expansion valve (see Section C6 - front valve or Section C9 - rear valve) (e) Renew expansion valve (see Section C6 - front valve or Section C9 - rear valve) (f) Clean expansion valve filter (see Section C6 - front valve or Section C9 - rear valve) and compressor filter (see Section C5) (g) Renew unit (see Section C7) (h) Clean condenser matrix surfaces (see Section C9 - Maintenance)

Chapter C

SYMPTOM	POSSIBLE CAUSE	ACTION
<p>3. Insufficient cooling of air flowing from air conditioning outlets—<i>continued</i></p>	<p>(i) Refrigerant hose and piping collapsed, kinked, or otherwise damaged, restricting flow of refrigerant</p> <p>(j) Compressor inlet filter at suction fitting clogged</p> <p>(k) Compressor not pumping sufficiently</p> <p>(l) Compressor inoperative — seized</p> <p>Front System Only</p> <p>(m) System uses outside air only and will not switch to recirculated air to give maximum cooling capacity</p> <p>(n) Coolant tap remains open in maximum heating position</p> <p>(o) Fault in coolant tap actuator</p>	<p>(i) Renew damaged hose or piping</p> <p>(j) Clean compressor and *expansion valve filters (see Sections C5, C6 and C9)</p> <p>(k) Dismantle compressor and renew parts if necessary (see Section C5)</p> <p>(l) Repair or renew compressor (see Section C5)</p> <p>(m) Dismantle recirculating flap linkage, clean, lubricate and adjust. Check actuator for correct operation (see Section C8)</p> <p>(n) Fit new coolant tap or actuator (see Section C1)</p> <p>(o) Fit new coolant tap actuator (see Section C1)</p>
<p>4. Excessive cooling of too little air</p>	<p>4. (a) *Suction throttling valve incorrectly adjusted, evaporator pressure lower than 30lb/sq. in. (2,11 kg/sq. cm.) at maximum cooling setting resulting in icing of evaporator and loss of cooling air flow</p> <p>(b) *Suction throttling valve stuck in fully open position, evaporator pressure pulls down below 30lb/sq. in. (2,11 kg/sq. cm.) resulting in icing of evaporator and loss of cooling air flow</p>	<p>4. (a) Adjust suction throttling valve (see Section C6 — front valve or Section C9 — rear valve)</p> <p>(b) Adjust suction throttling valve. If valve does not respond to adjustment, repair or if necessary renew (see Section C6 — front valve or Section C9 — rear valve)</p>
<p>5. Noise or vibration</p>	<p>5. (a) Loose compressor belt</p> <p>(b) Loose compressor mountings</p> <p>(c) Damaged compressor shell or worn internal parts</p> <p>(d) *Defective expansion valve</p>	<p>5. (a) Adjust belt tension (see Section C5)</p> <p>(b) Tighten compressor mountings (see Section C5)</p> <p>(c) Repair or renew compressor (see Section C5)</p> <p>(d) Renew expansion valve (see Section C6 — front valve or Section C9 — rear valve)</p>
<p>Front System Only 6. Upper quantity actuator operates in refrigeration position</p>	<p>6. (a) Fault in diode</p>	<p>6. (a) Fit new diode (see Chapter M - Distribution Board)</p>

*On Long Wheelbase cars fitted with a centre division, check the front or rear component, whichever is suspect e.g. if there is insufficient air flow from the air conditioning outlets in the front compartment check the front blower motors and if there is insufficient air flowing from the outlets in the rear compartment quarter panels check the rear refrigeration unit blower motors.

Section C11

WORKSHOP TOOLS

<i>Tool Number</i>	<i>Description</i>
RH 529	Spring Balance – 0 to 25 lb.
RH 530	Thermometer
RH 7789 (J-9397)	Compressing Fixture – Compressor
RH 7790 (J-9432)	Bearing Installer – Compressor
RH 7791 (J-8433)	Extractor – Compressor Pulley
RH 7792 (J-9395)	Pilot – Compressor Pulley
RH 7793 (J-9392)	Seal Fitting and Extracting Tool – Compressor Shaft (Carbon type seal)
RH 7794 (J-8092)	Universal Handle – Compressor (For use with Tools RH 7791 and RH 7795)
RH 7795 (J-9398)	Pulley Bearing Remover – Compressor
RH 7796 (J-9481)	Pulley and Bearing Installer – Compressor
RH 7797 (J-21303)	Seal Protector – Compressor
RH 7798 (J-9403)	Clutch Holding Tool – Compressor
RH 7799 (J-9480)	Fitting Tool – Clutch Plate and Hub – Compressor
RH 7800 (J-9401)	Extractor – Clutch Plate and Hub – Compressor
RH 7801 (J-9402)	Parts Tray – Compressor
RH 7802 (J-9393)	Extraction and Fitting Tool – Seal Seat – Compressor

Chapter C

<i>Tool Number</i>	<i>Description</i>
RH 7803 (J-9521)	Support Block – Internal Mechanism – Compressor
RH 7934	Adjuster – Suction Throttling Valve
RH 7937	Adaptor – Schrader Valve
RH 8342 (J-23128)	Seal Fitting and Extracting Tool – Compressor Shaft (Ceramic type seal)