

Chapter J

THE FINAL DRIVE

**(Comprising The Final Drive Unit, Half-shafts,
Final Drive Crossmember and Rear Hubs)**

SECTION	PAGE
J1 The Final Drive Unit	J1
J2 The Final Drive Half-shafts	J13
J3 The Final Drive Crossmember	J19
J4 The Rear Hubs, Stub Axles and Drive-shafts	J21
J5 Dimensional Data	J25

Chapter J

THE FINAL DRIVE

Section J1

THE FINAL DRIVE UNIT

Overhaul

Final drive unit—To remove

1. Place the car on a ramp and securely chock the road wheels.
2. Disconnect the battery, located in the boot.
3. Remove the drain plug from the final drive casing and allow the lubricant to drain into a clean container. Slacken the filler plug to speed up draining operation. It is advisable to carry out this operation when the unit is warm, immediately after the car has completed a run. After draining, clean and fit the drain plug with a new aluminium washer.
4. Remove the pinch bolts from the mounts supporting the rear section of the exhaust system; support the pipe and remove the clamp bolts from the joint clamp. Separate the joint and remove the exhaust system rear section.
5. Disconnect the propeller shaft from the differential pinion flange by removing the four bolts and nuts.
6. Disconnect the half-shaft outer universal joints from the hubs by removing the eight clamping set-screws; remove the four clamps. To uncouple the joints ease the half-shafts inwards.

Note To perform Operations 5 and 6 it may be necessary to jack up a rear wheel and rotate it in order to gain access to all the necessary nuts and bolts.

7. Support the half-shafts to prevent excessive strain being imposed on the neoprene seals of the ball and trunnion joint. Place hardwood block beneath trailing arm, as near to the hub as possible, to prevent excessive strain being imposed on the rebound straps.
8. Place a jack under the final drive casing to support it.
9. Release the torque arm front mount from the rear suspension sub-frame by removing the two lower bolts and nuts which secure the torque arm flange to the mount lower support plate (see Fig. J13).
10. Remove the sixteen nuts and washers securing the final drive unit to the cross-member noting the position of the eight special interlocking washers. Support the half-shafts, ease the final drive unit away from the cross-member and lower it from the car.

Note If the final drive unit is not to be dismantled, fit and tighten the four rear cover retaining nuts and washers adjacent to the two dowels.

Chapter J

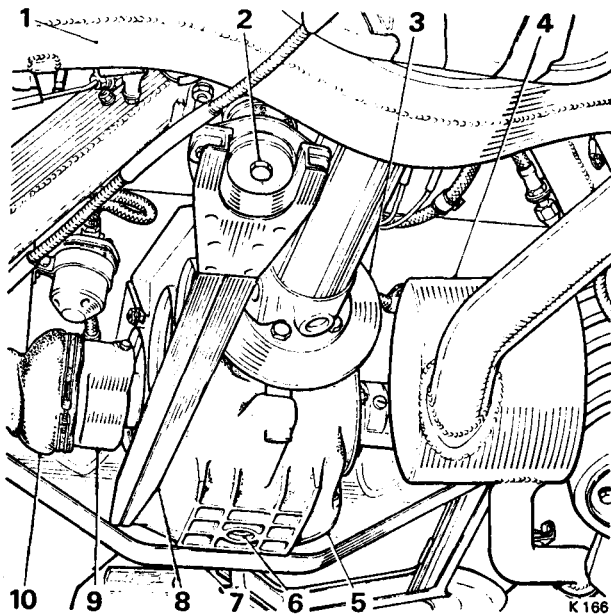

FIG. J1 FINAL DRIVE UNIT—IN POSITION

- 1 Rear suspension sub-frame
- 2 Torque arm front mount
- 3 Transmission damper
- 4 Modified exhaust swirl chamber
- 5 Final drive unit
- 6 Final drive drain plug
- 7 Final drive cross-member
- 8 Torque arm
- 9 Ball and trunnion joint
- 10 Convoluted seal

Final drive unit—To dismantle

It should be noted that exchange final drive units, less half-shafts, are available for Service replacements.

It must be noted also that crown wheel and pinion gears are supplied as lapped pairs and as such, they must not be separated or fitted independently.

1. Carry out Operations 1 to 10, inclusive, of 'Final drive unit—To remove'.
2. Remove the right-hand half-shaft assembly, remove the distance piece, and the three Belleville washers and adjusting washer from behind the housing.
3. Remove the left-hand half-shaft assembly and remove the large adjusting washers fitted between the housing and the large crown wheel bearing.
4. Remove the large cover from the rear of the housing.

5. Remove the nuts and washers from the bearing cap on each side of the crown wheel and differential assembly (see Fig. J3).

6. Remove the two bearing caps, and lift the crown wheel and differential assembly from the casing.

Note (a) The crown wheel and differential assembly cannot be lifted directly out of the final drive casing, but must be removed by lifting the crown wheel slightly, then moved away from the pinion and carefully past the pinion nose bearing bridge.

(b) Precautions should be taken during Operation 5 to ensure that the two large taper roller bearing tracks do not fall off, as this could result in damage to the rollers or tracks.

7. Remove the four setscrews which secure the pinion housing to the front flange of the casing and insert extractor screws into the two tapped holes in the pinion housing flange.

8. Place the casing in an oven having a temperature of approximately 80°C (176°F) for approximately one hour.

9. Remove the casing from the oven and extract the pinion housing using the two extractor screws, taking care to turn the screws evenly and together.

10. Remove the two socket headed screws, the two retaining nuts and washers, and remove the pinion nose bearing.

Crown wheel and differential assembly— To dismantle

1. Remove the bearing outer tracks.
 2. Remove the twenty nuts, washers and bolts securing the crown wheel to the differential housing; remove the crown wheel.
 3. Unlock and remove the eight setscrews securing the differential housing end cap; remove the cap, splined pinion gear and adjusting washer.
 4. Remove the nut and long setscrew which runs through the centre of the split trunnion pin; remove the trunnion pins, bevel gears and dished thrust washers (see Fig. J2).
 5. Remove the splined pinion gear and adjusting washer from the other end of the housing.
- Note** All washers should be attached to their appropriate gears to ensure that they are fitted in their original positions.

If it is necessary to renew the large taper roller bearings, they should be pressed off the differential housing and end cap.

6. Wash all parts thoroughly and dry with compressed air.

7. Thoroughly inspect all components for wear or damage marks and renew any defective items. The adjusting washers, excluding the dished thrust washers behind the bevel gears, should all be flat and parallel. Ensure that all bearing surfaces and bores are free from damage, pitting or burrs and that all gears are free from damage or excessive wear.

Crown wheel and differential assembly— To assemble

Prepare the washed and inspected parts, complete with any new or replacement parts, for assembly which is a careful reversal of the dismantling procedure as follows:

1. If new taper roller bearings are to be fitted, they must be pressed squarely on to the diameters on the end of the differential housing and end cap noting that, the larger of the two bearings is fitted to the housing and that both bearings are fitted correctly against their abutment faces (see Fig. J9).

2. If the adjusting washer positions are not known or if new pieces are being fitted the following procedure is recommended for assembling the differential housing as described in Operations 3 to 6 inclusive.

3. Fit the splined bevel pinion into the end of the differential housing without an adjusting washer behind the head.

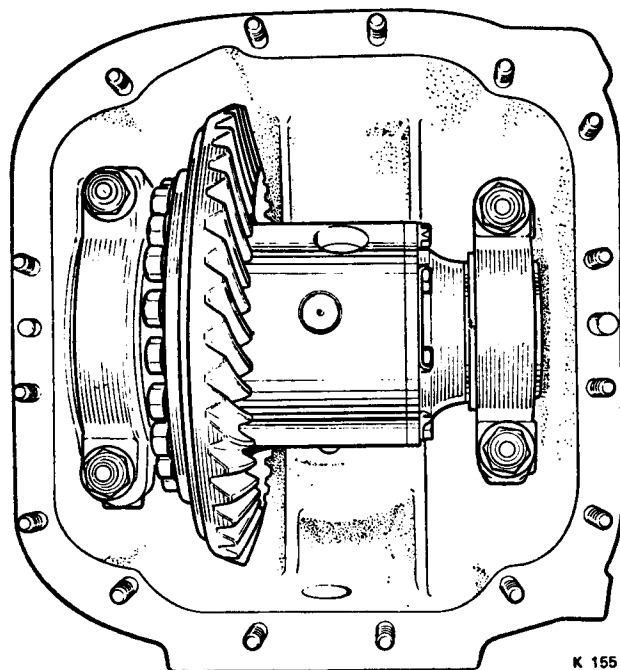

K 155

FIG. J3 DIFFERENTIAL HOUSING AND CROWN WHEEL IN POSITION

4. Fit the trunnion pins, dished washers and bevel gears; the long bolt and nut which connects the split trunnion pin should be torque tightened to between 8 lb. ft. and 10 lb. ft. (1,10 kg.m. and 1,38 kg.m.).

5. Push the splined pinion gear into mesh with the bevel gears as far as possible and measure the distance from the end of the differential housing to the end face of the bevel gears.

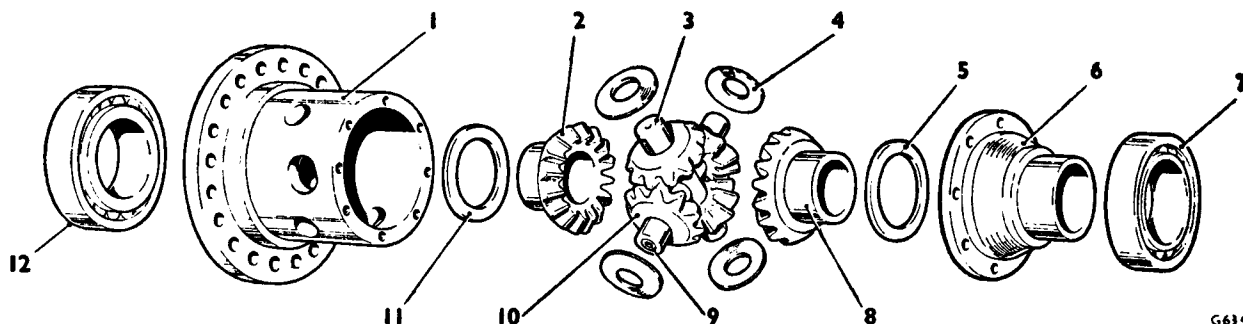

G 634

FIG. J2 DIFFERENTIAL HOUSING—EXPLODED VIEW

- | | | |
|-----------------------------|--------------------------------|-------------------------|
| 1 Differential gear housing | 5 Adjusting washer | 9 Split trunnion pin |
| 2 Splined bevel pinion | 6 Differential housing end cap | 10 Differential gears |
| 3 Trunnion pin | 7 Taper roller bearing | 11 Adjusting washer |
| 4 Dished thrust washer | 8 Splined bevel pinion | 12 Taper roller bearing |

Chapter J

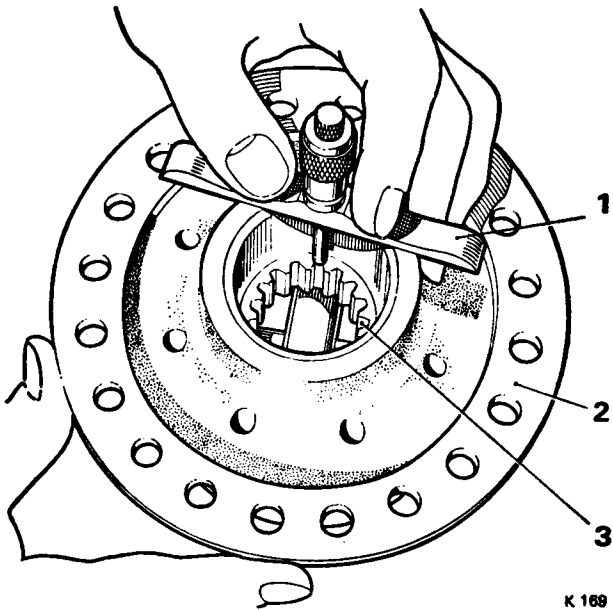

FIG. J4 SPLINED BEVEL PINION MEASUREMENT

- 1 Micrometer
- 2 Differential gear housing
- 3 Splined bevel pinion

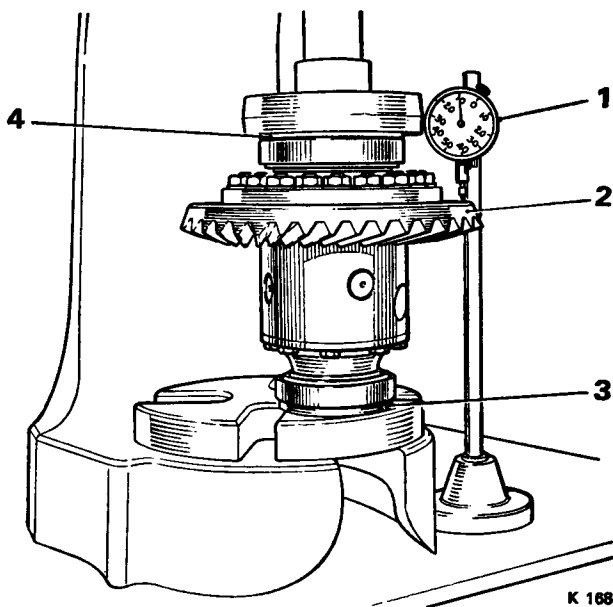

FIG. J5 CHECKING THE CROWN WHEEL FOR TRUTH

- 1 Dial test indicator
- 2 Crown wheel and differential housing assembly
- 3 Adjusting washer
- 4 Adjusting washer

6. Pull the gear back out of mesh as far as possible and again measure from the end of the housing to the end of the gear (see Fig. J4).

The difference between these two measurements will give the nominal size of adjusting washer required behind the gear head.

7. Dismantle the gears and then assemble them with the correct adjusting washer fitted behind the bevel pinion.

Adjusting washers are available in a range from 0.084 in. to 0.116 in. (2.13 mm. to 2.94 mm.) in 0.002 in. (0.05 mm.) increments and they must be fitted with the chamfer and the oil grooves against the back face of the gear.

8. Rotate the gears to ensure that they are perfectly free, but without backlash, if necessary vary the thickness of the adjusting washer.

9. Fit the housing end cap and the other splined bevel pinion and repeat Operations 3 to 7, inclusive, to determine the thickness of the adjusting washer required.

Note When the unit is assembled correctly the gears should run freely without tight spots and without backlash.

10. When the differential gears are correctly set, lock the setscrews securing the differential housing end cover by turning over the washer tabs.

11. Fit the crown wheel to the end of the housing and torque tighten the setscrews to the standard figures relative to size (see Chapter P).

12. Check the crown wheel for axial run-out.

Any convenient method may be employed to check this, e.g. on a mandrel between the centres, but one method which may be used is described in Operations 12 to 14, inclusive.

13. Place the roller bearing outer tracks in position, and stand the assembly on one end in a press with an adjusting washer fitted to each bearing (see Fig. J5).

14. Apply light pressure and, using a dial test indicator, check the run-out of the crown wheel; the run-out should not exceed 0.002 in. (0.05 mm.).

15. If the run-out exceeds this figure different crown wheel positions relative to the differential housing should be tried until the run-out is within the 0.002 in. (0.05 mm.) limit.

Pinion housing—To dismantle

- 1. Remove and discard the 'O' ring fitted to the pinion housing.
- 2. Unlock and remove the nut securing the pinion flange and damper; remove the flange using the

Chapter J

special hydraulic ram (RH 8017) and special extractor beam (RH 8033).

3. Remove the pinion oil seal and the oil flinger fitted behind it.

4. Place the housing in a press with the pinion gear downward and the housing lower end firmly supported and carefully press the pinion out of the housing.

5. Collect the adjusting washers from the pinion shank and the taper roller bearing from the housing.

6. If new taper roller bearings are to be fitted, the outer tracks must be removed from the housing, using a soft drift and a hammer, taking care to avoid damage to the bearing locating bores.

7. The large roller bearing should be removed from beneath the pinion head using a press and the special tool (RH 7863).

8. Wash all parts thoroughly in paraffin and dry with compressed air.

9. Inspect all parts for serviceability, and any showing damage, pitting or excessive wear should be renewed.

Pinion housing—To assemble

Prepare the washed and inspected parts, complete with any new or replacement parts for assembly, as follows.

1. Lightly lubricate all components paying particular attention to the roller bearing races.

2. If new bearings are being fitted, carefully press the outer tracks into the housing and the large roller bearing on to the pinion, ensuring that the bearings are square and right up to their abutment faces.

3. Enter the pinion into the housing then fit the two adjusting washers on to the pinion shank (see Fig. J6).

Note On cars produced from car numbers SRH 4231-Standard cars, CRH 5003-Coachbuilt cars and 5RX 6159-cars built to meet the American Federal Safety Standard Requirements, a spacer is fitted to the final drive pinion between the large roller bearing and the adjusting washers (see Fig. J6).

The two washers determine the pre-load on the pinion bearing and it is important that the washers are free from defects and are flat and parallel to within 0.001 in. (0.025 mm.).

If the pinion assembly bearings have not been renewed, the original washers may be used. If new

bearings have been fitted, experience has shown that washers whose combined thickness amounts to between 0.270 in. and 0.280 in. (6.85 mm. and 8.89 mm.) should give the best initial setting.

4. Support the pinion and housing and press the upper bearing on to the pinion shank until it abuts the adjusting washers.

5. Fit the oil flinger and a new seal to the housing with the front face of the seal just flush with the face of the housing and the seal lip pointing inward.

6. Fit the transmission damper to the pinion flange and enter the flange into the housing, taking care not to damage the seal, and fit the lock washer and nut.

7. Tighten the nut to a torque figure of between 275 lb. ft. and 300 lb. ft. (38 kg.m. and 41.46 kg.m.) locking the pinion flange using the special tool (RH 7862). Do not turn over the tab of the lock-washer.

8. Rotate the pinion several times in both directions then check the pre-load.

The pre-load on the pinion bearings when the housing is out of the final drive casing should be

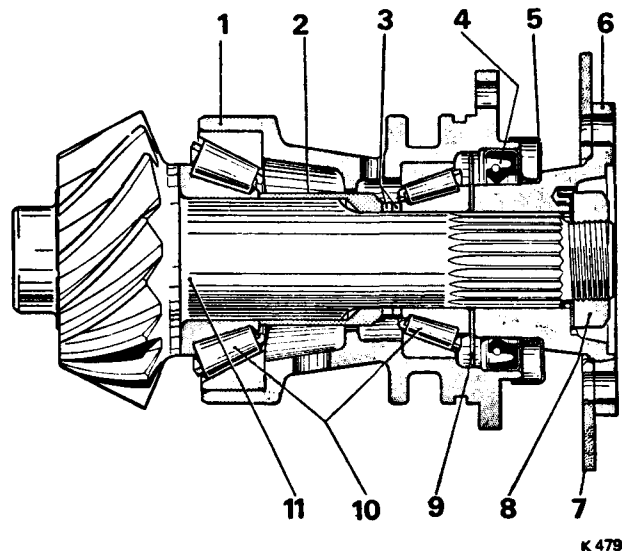
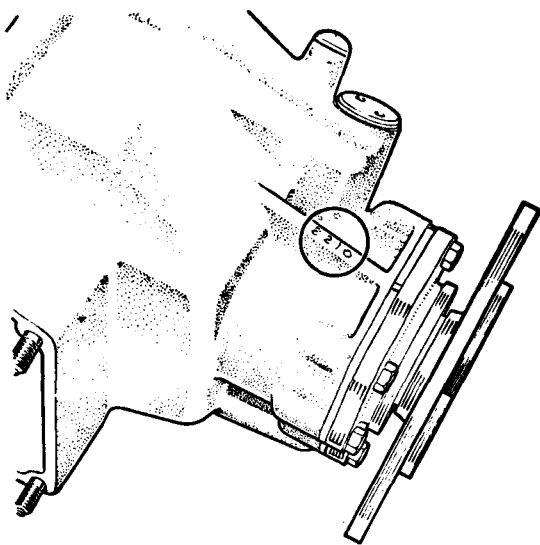

FIG. J6 PINION HOUSING CROSS-SECTION

- 1 Pinion housing
- 2 Spacer (if fitted)
- 3 Pre-load adjusting washers
- 4 Oil seal
- 5 Shield
- 6 Pinion flange
- 7 Damper
- 8 Pinion flange nut
- 9 Oil flinger
- 10 Taper roller bearings
- 11 Pinion

Chapter J



K 156

FIG. J7 STAMPED DIMENSION ON FINAL DRIVE CASING

between 8 lb. in. and 10 lb. in. (0,092 kg.m. and 0,115 kg.m.) and this is best checked using a spring balance pulling on a bolt inserted into one of the holes in the pinion flange.

Note The holes in the pinion flange are 1.875 in. (4,762 cm.) away from the centre of the pinion and therefore if this method is used the spring balance reading should be between 4.3 lb. and 5.3 lb. (1,949 kg. and 2,403 kg.).

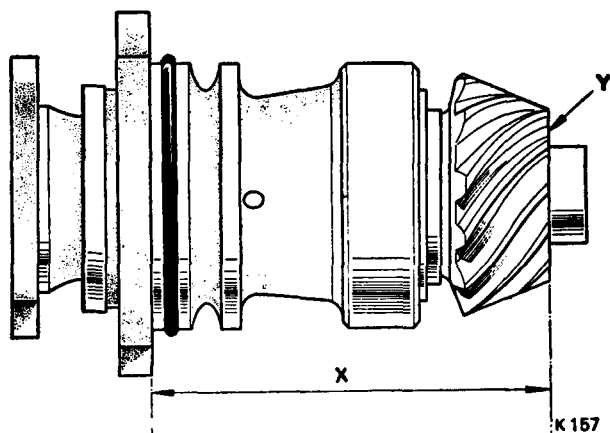

K 157

FIG. J8 PINION HOUSING MEASUREMENT

X Dimension between housing and pinion gear

Y Dimension etched on pinion gear face

The spring balance reading obtained to initially rotate the pinion will be high. It is the lower steady reading when the pinion is rotating, which indicates the pre-loading.

9. If the pre-load is not correct the pinion must be extracted from the housing and the adjusting washers changed as necessary to obtain the correct reading.

Adjusting washers are available in a range from 0.105 in. to 0.110 in. (2,66 mm. to 2,79 mm.) and 0.110 in. to 0.160 in. (2,79 mm. to 4,06 mm.) in 0.001 in. (0,025 mm.) and 0.005 in. (0,127 mm.) increments respectively.

Reducing the combined thickness of the washers will increase the pre-load and increasing the thickness will reduce it but, it must be noted that very small changes to the thickness of the washers has a marked effect on the pre-load figure.

10. When the pinion has been pre-loaded correctly, turn over the tab on the lock-washer fitted under the pinion flange retaining nut.

Final drive unit—To assemble

To assemble the final drive unit reverse the procedure given for dismantling ensuring that the crown wheel and pinion are in their correct relative positions and that there is the correct amount of backlash between the two gears.

All parts must be cleaned thoroughly prior to assembly and all bearings, other than new ones, lubricated.

1. Before commencing to assemble the final drive unit, the stiffening bar (RH 8032) should be fitted to the final drive casing.

2. Partly screw four 3/8 in. U.N.F. studs into the threaded holes in the front of the final drive casing. It is sufficient to fit these studs by hand as they serve only as location pegs for the pinion housing.

3. If the pinion nose bearing was removed from the casing previously, fit the bearing, and the two socket headed retaining screws, nuts and washers.

Note the dimension stamped on the cast rib, just above the front flange of the final drive casing (see Fig. J7).

4. Place the differential casing in an oven at a temperature of 80°C (176°F) for approximately 1 hour.

5. Carefully measure from the back face of the pinion housing front flange to the face of the pinion gear, adjacent to the nose bearing diameter (dimension X Fig. J8).

Chapter J

6. Add this figure to the dimension etched on the rear face of the pinion gear (*dimension Y Fig. J8*).

The figure stamped on the front of the final drive casing, which was noted previously, must now be subtracted from the total of X and Y and the resulting dimension gives the thickness of the split adjusting washer which must be used between the pinion housing flange and the casing, to place the pinion in the correct position.

Thickness of washer = $X + Y - A$.

Note The above measurements must be taken carefully and accurately.

Split adjusting washers are available in a range from 0.100 in. to 0.149 in. (2,54 mm. to 3,784 mm.) in 0.012 in. (0,304 mm.) increments and are marked with a letter to denote the size. Both halves of the washer to be fitted must have the same letter marked on them.

7. Remove the casing from the oven and fit the split adjusting washers over the studs.

8. Fit a new 'O' ring to the pinion housing and insert the housing into the casing as far as possible.

Note The pinion housing has one off-set hole and can therefore only be fitted in one position. It is advisable to establish this position before entering the housing into the casing.

9. Remove the four locating studs, fit the four retaining setscrews and tighten them progressively and evenly. The setscrews should be finally tightened in accordance with the standard figures, relative to the size, given in Chapter P.

10. **When the casing has cooled** the pinion pre-load should be checked, using the same method as described under 'Pinion housing—To assemble', Operation 8;

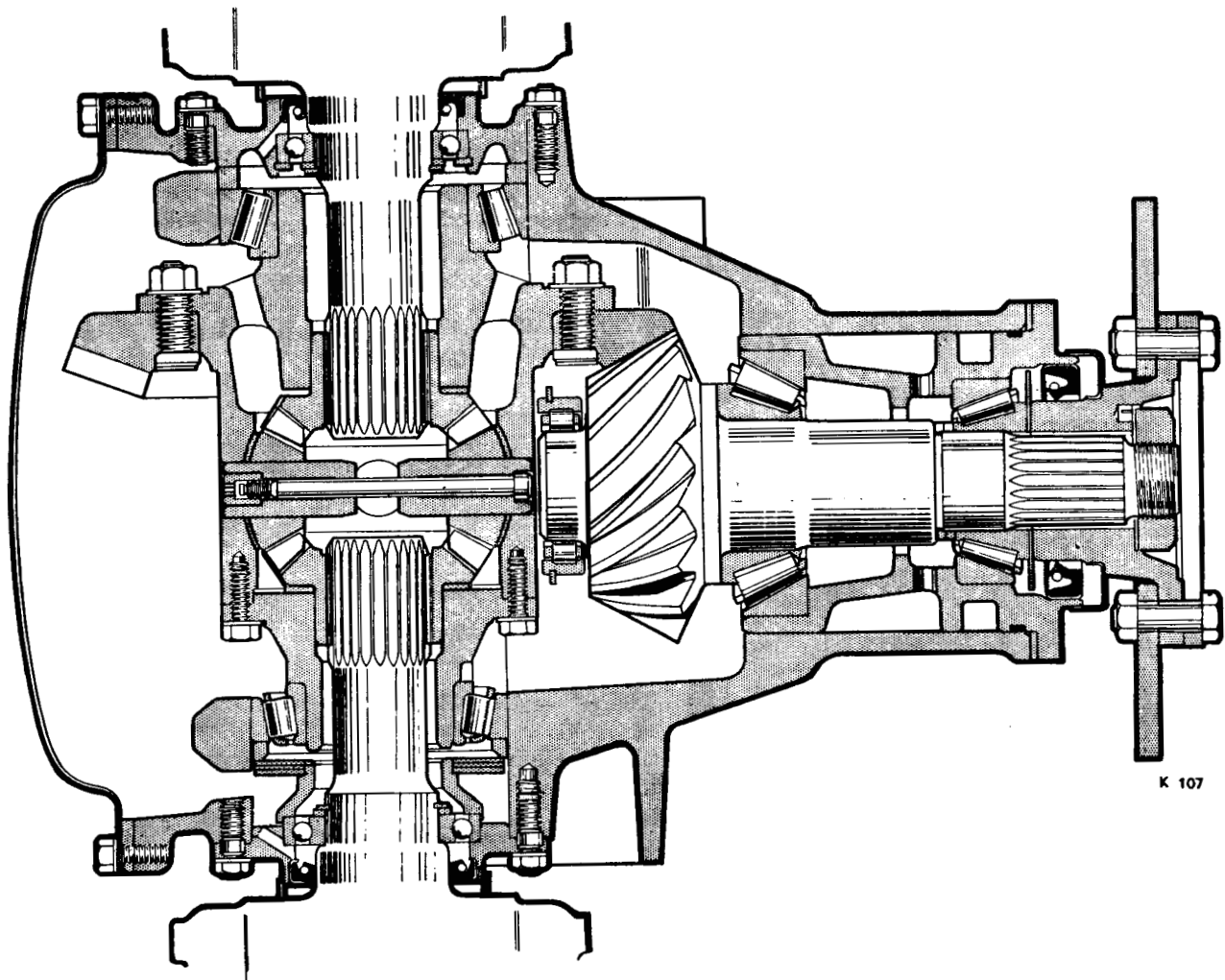
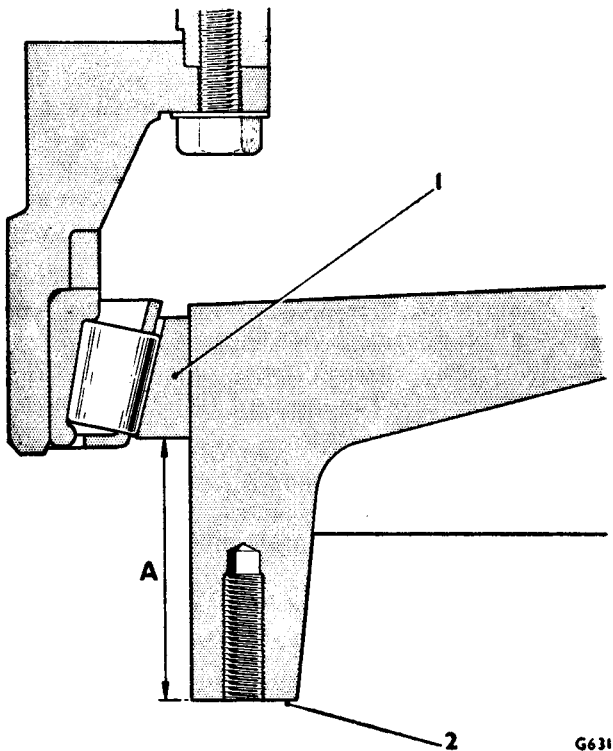

FIG. J9 CROSS-SECTION—FINAL DRIVE UNIT

Chapter J



G631

FIG. J10 MEASUREMENT—CASING FLANGE TO BEARING

- A** Measurement flange to bearing
- 1** Bearing outer track
- 2** Final drive casing flange

the reading should not exceed 30 lb. in. (0,346 kg.m.) when the housing is fitted to the final drive casing.

Note If the method previously described is used, the corrected maximum reading, allowing for the flange bolt hole being 1.875 in. (4,76 cm.) from the pinion centre, is 16 lb. (7,25 kg.).

11. Examine the crown wheel and note the backlash figure etched on the back face.
12. Carefully fit the crown wheel and differential assembly in position; fit the bearing caps, but do not tighten the nuts.
13. If the two final drive side housings are still connected to the half-shafts, remove the retaining circlips and remove the housings from the shafts.
14. Fit the adjusting washer with the chamfered face outward, three belleville washers with the convex side outward, distance piece and housing to the right-hand side of the final drive casing, and progressively tighten the housing securing nuts.

Note The housing has an off-set hole and can be fitted in one position only.

15. Fit the two adjusting washers behind the crown wheel bearing and fit the left-hand side housing. Progressively tighten the housing nuts whilst rocking the crown wheel back and forth to ensure that there is still backlash between the gears.

16. Mount a dial test indicator on the final drive casing with the indicator pad on the flank of a crown wheel tooth.

17. Zero the indicator and rock the crown wheel back and forth noting the backlash.

18. The backlash should be checked at twelve positions around the crown wheel and an average reading taken. This figure should conform to the backlash figure etched on the crown wheel.

19. If it does not conform, the thickness of the washers behind the crown wheel bearing must be varied to obtain the correct reading.

These washers are available in a range from 0.111 in. to 0.129 in. (2,819 mm. to 3,27 mm.) in increments of 0.002 in. (0,050 mm.) and it can be assumed that 0.001 in. (0,025 mm.) variation in the thickness of the adjusting washer will make a difference of 0.001 in. (0,025 mm.) to the backlash.

20. If necessary, to obtain the desired results, grind equal amounts from each side of the washer taking great care to ensure that, after grinding, the washer is still flat and parallel to within 0.001 in. (0,025 mm.).

21. When the backlash is correct, remove the side housing and fit it to the half-shaft.

22. Fit the complete assembly to the final drive casing after applying a light coating of SQ 32M jointing compound to the joint faces of the casing and housing.

23. Remove the right-hand housing, distance piece, belleville washers and adjusting washer.

24. Accurately measure the distance from the casing flange to the taper roller bearing outer track (*see Fig. J10*).

25. Place the housing, distance piece and belleville washers in the checking jig (RH 7861) and tighten the jig end pieces until the belleville washers are flat (*see Fig. J11*).

26. Using feeler gauges, measure the distance between the housing flange face and the top of the two pins on the gauge. The result, added to the nominal pin height marked on the gauge gives the distance from the side housing to the belleville washer.

27. Subtract this dimension from the dimension previously taken between the casing flange and taper bearing; the result gives the thickness of the adjusting

washer which must be fitted between the belleville washers and the bearing, to give the correct pre-load.

Adjusting washers are available in a range from 0.200 in. to 0.260 in. (5.08 mm to 6.60 mm.) in increments of 0.010 in. (0.254 mm.). Washers may be lightly ground to obtain the correct dimension but if this is done, equal amounts must be removed from each side and the washer must be kept flat and parallel.

28. Fit the right-hand side housing to the half-shaft.

29. Fit the correct washer with the chamfered side outward. Fit the three belleville washers, convex side outward, fit the distance piece, housing and half-shaft assembly after applying a light coating of SQ 32M jointing compound to the flange faces.

30. Tighten the housing securing nuts progressively and evenly and finally torque tighten them in accordance with the standard figures, relative to size, given in Chapter P.

31. Torque tighten the nuts securing the two large bearing caps in accordance with the standard figures given in Chapter P.

32. Remove the stiffening bar (RH 8032), fit the gasket and end cover. Fit and tighten the four nuts and washers adjacent to the two dowels, if the final drive unit is not being fitted to the car immediately. These nuts should remain in place until the final drive unit is being fitted to the final drive cross-member.

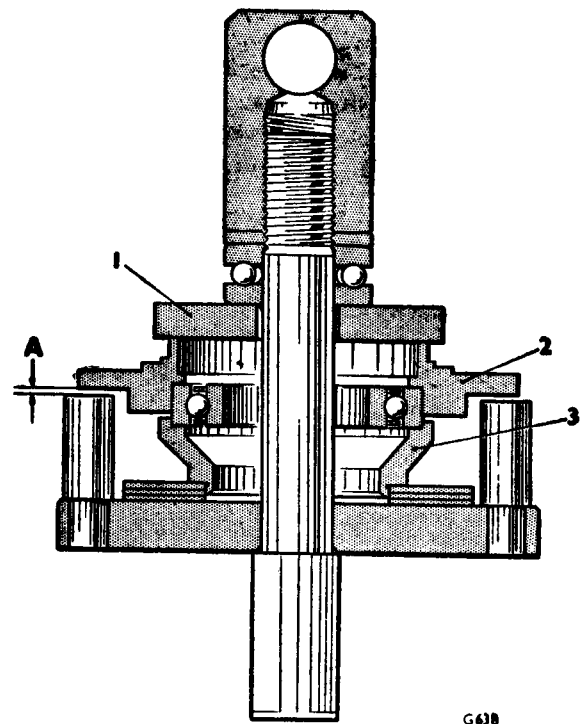

FIG. J11 BELLEVILLE WASHER SETTING

- A Measured gap
- 1 Tool RH 7861
- 2 Final drive side housing
- 3 Distance piece—Belleville washers

Final drive unit—To fit

To fit the final drive unit reverse the procedure given for removal noting the following points.

1. The half-shafts must be supported when offering up the final drive unit to the car.

2. Remove the four nuts and washers retaining the final drive rear cover.

3. Offer up the final drive unit to the final drive cross-member and fit the sixteen nuts and washers, taking care to position the eight interlocking washers correctly. These eight washers fit beneath the plain nuts and washers at each corner pair of studs with the fingers correctly interlocked (see Fig. J12).

4. Care must be taken to ensure that the half-shaft outer joints are located correctly in the hubs and that the caps are correctly fitted, so that the retaining strap on the joint is located in the recess in the cap.

5. The propeller shaft and pinion flanges must be cleaned before being bolted together.

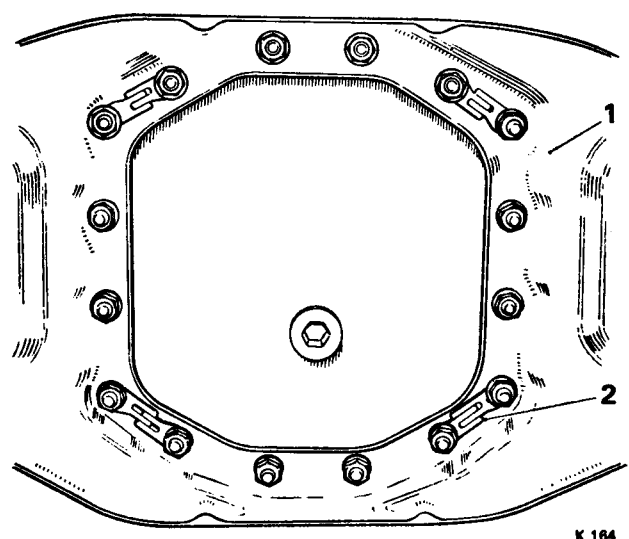

FIG. J12 FINAL DRIVE END COVER

- 1 Final drive cross-member
- 2 Interlocking washers

Chapter J

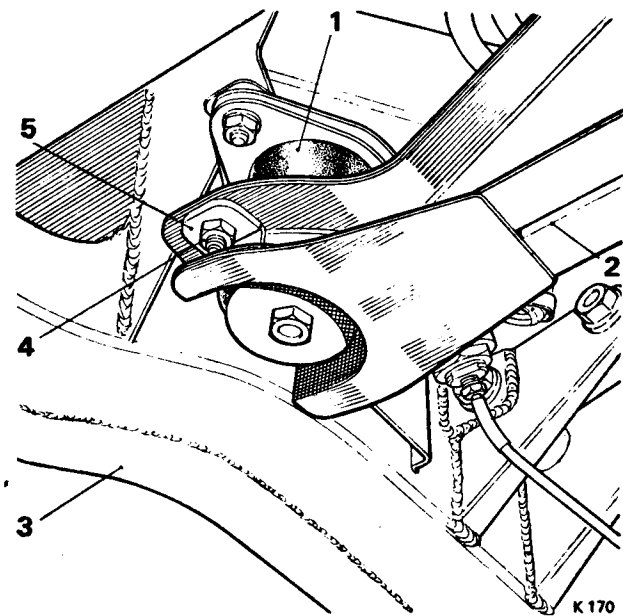

FIG. J13 TORQUE ARM FRONT MOUNT

- 1 Rubber mount
- 2 Torque arm
- 3 Rear suspension cross-member
- 4 Torque arm securing setscrews
- 5 Heavy duty washers

6. When refitting the rear section of the exhaust system, care must be taken to obtain a good pipe run. The exhaust mounts must be 'set' to allow for system expansion (see Chapter Q—'Exhaust System').

Torque tighten all bolts and nuts in accordance with the standard figures, relative to size, given in Chapter P of this Manual.

7. After fitting the final drive unit, remove the plug in the rear cover and fill the axle with one of the recommended lubricants up to the level of the plug (approx. 4½ pt., 2.55 litres).

8. Fit the filler plug with a new aluminium washer.

Torque arm—To remove

Removal of the torque arm can be carried out without disturbing the final drive unit.

1. Place the car on a ramp and securely chock the road wheels.
2. Disconnect the battery which is located in the boot.

3. Remove the two nuts, bolts and heavy duty washers securing the torque arm to the mount on the rear suspension cross-member (see Fig. J13).

4. Remove the six nuts and washers which secure the torque arm to the final drive casing; remove the torque arm.

5. Inspect the torque arm mount on the rear suspension cross-member for failure or softening of the rubber and renew if necessary.

6. When a torque arm has been removed from a car it should be cleaned and visually inspected for serviceability.

Torque arm—To fit

Fit the torque arm by reversing the procedure given for removal noting the following points.

1. All nuts and bolts must be torque tightened to conform with the standard figures given in Chapter P.
2. It is essential that the heavy duty washers are fitted to the front mount (see Fig. J13).

Pinion flange oil seal—To renew

The pinion flange oil seal may be renewed without disturbing the final drive unit.

1. Place the car on a ramp and securely chock the road wheels.
2. Disconnect the battery, located in the boot.
3. Remove the four bolts and nuts securing the propeller shaft to the pinion flange.
4. Remove the four bolts and nuts securing the propeller shaft front flange to the transmission output flange.
Ease the propeller shaft forward and downward sufficiently for the rear flange to be clear of the final drive pinion flange. It is not necessary to remove the propeller shaft completely.
5. Turn back the locking tab on the pinion nut lock washer and remove the nut, using the locking tool (RH 7862). Remove and discard the lock washer.
6. Using the hydraulic ram (RH 8017) and special extractor beam (RH 8033), remove the pinion flange.
7. Using a lever, or a simple extractor, remove the oil seal from the pinion housing.
8. Fit a new oil seal, ensuring that it is fitted squarely, with the lip pointing inward and the front face of the seal just flush with the front face of the housing (see Fig. J6).

Chapter J

9. Clean and fit the pinion flange and damper, fit a new lock washer and the nut, and using the locking tool (RH 7862) tighten the nut to between 275 lb. ft. and 300 lb. ft. (38 kg.m. and 41,5 kg.m.). Turn over the locking tab.

10. Connect the propeller shaft at both ends (see Chapter F—Propeller shaft and universal joints).

Transmission damper—To remove

1. Carry out operations 1-6 as listed under 'Pinion flange oil seal—To renew'.

2. Remove the transmission damper from the pinion flange.

3. Clean and inspect the damper for serviceability and renew if necessary.

Transmission damper—To fit

Fit the transmission damper to the final drive pinion flange by reversing the removal procedure.

1. Carry out Operations 9 and 10 of 'Pinion flange oil seal—To renew'.

Note When the transmission dampers were first introduced they took the form of a viscous damper, but a change was made on production to the present plate type damper. If a viscous damper is damaged and is to be replaced the later plate type damper will be supplied as a spare, and should be fitted. The change to the plate type damper was made commencing with car numbers SRH 3380—Standard cars, and CRH 3490—Coachbuilt cars.

It is not possible to fit either damper to cars not previously embodying them unless the necessary changes are made to the exhaust system.

i.e. the shortened swirl chamber and modified run of the intermediate exhaust pipe (see Fig. J1).

A new pinion flange having a spigot machined on it to locate the damper is also required, plus longer propeller shaft to pinion flange attachment bolts.

Section J2

FINAL DRIVE HALF-SHAFTS

Overhaul

Half-shaft—To remove

The half-shafts can be removed from the car with the final drive unit in position.

Exchange half-shaft assemblies are available, complete with ball and trunnion joint, seal and Hardy Spicer joints.

If a half-shaft is to be removed and an exchange assembly fitted, proceed as follows.

1. Place the car on a ramp and securely chock the road wheels.
2. Disconnect the battery which is located in the boot.
3. Disconnect the outer universal joint from the hub by removing the four setscrews and the two clamps (*see Fig. J14*); it may be necessary to jack up the wheel and rotate the half-shaft to gain access to all the setscrews.
4. Ease the shaft inward to disengage the joint; support the shaft to avoid excessive strain on the ball and trunnion joint seal. One convenient method of doing this is to suspend the shaft on a piece of cord or wire looped round the final drive cross-member.

5. Remove the six nuts and washers securing the bearing housing to the side of the final drive casing; tap the housing around its circumference with a soft headed mallet to 'break' the joint then ease the housing out of the casing and remove the half-shaft assembly.

Note When removing a right-hand (off-side) half-shaft great care must be exercised when withdrawing the housing owing to the location of the belleville washers and distance piece behind it (*see Fig. J9*). As the housing is eased away from the final drive casing, a slim rod or screwdriver should be inserted to prevent the possibility of the belleville washers falling down into the final drive casing.

When handling the half-shaft assembly, both ends should be supported. Do not carry the shaft holding one end only or place the joint in any position, where both ends are not supported. Also the shaft should not be placed with the ball and trunnion joint body downward otherwise oil may be lost through the small breather hole in the centre of the splined shaft.

6. After removal of the half-shaft, the final drive casing must be securely blanked off to prevent the ingress of dirt.

Chapter J

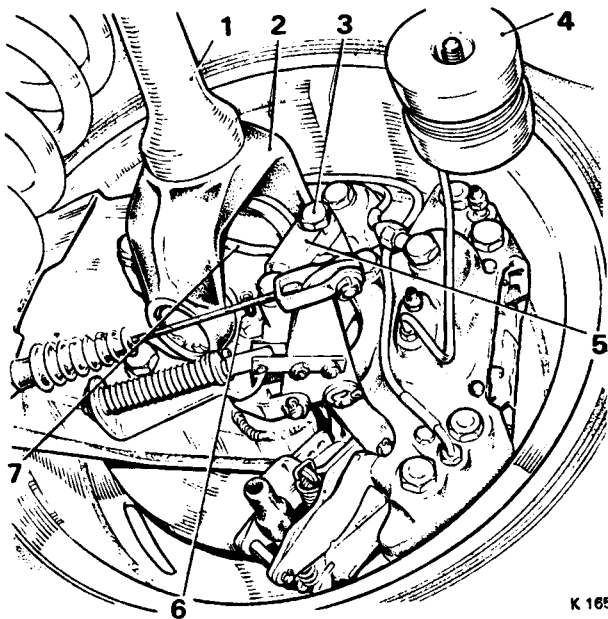

FIG. J14 HARDY SPICER OUTER JOINT

- 1 Half-shaft outer end
- 2 Hardy Spicer universal assembly
- 3 Bearing cap retaining setscrew
- 4 Harmonic damper
- 5 Bearing Cap
- 6 Grease nipple
- 7 Retaining strap, Hardy Spicer races

Half-shaft—To dismantle

1. Remove the circlip and washer retaining the ball and trunnion joint body and housing and remove the housing from the splined shaft.
2. Remove the drain plug from the joint housing and drain the oil from the housing (each joint holds approximately 150 c.c. of S.A.E.90 EP lubricant); after draining, clean and refit the plug.
3. Release the large clip, securing the convoluted seal to the joint body.
4. Position the shaft with the drain plug horizontal, ease the seal over the edge of the body and carefully withdraw the ball and trunnion assembly, taking care when handling the shaft not to dislodge the button assemblies.
5. Remove the trunnion buttons, adjusting washers, bearing outer races and needle rollers from the trunnion pin (see Fig. J15). Keep each assembly separate from the other and note from which side of the pin each assembly has been removed.

6. Whilst dismantled, the trunnion bearing assemblies should be lubricated and wrapped in greaseproof paper for protection.

7. If the Hardy Spicer outer joint is to be removed, clean any paint or dirt away from the yoke eyes, and using circlip pliers remove the circlip retainers.

8. Hold the half-shaft horizontally and using a hide mallet, shock drive the bearing races from their locations (see under 'Hardy Spicer joint—To remove').

Care must be taken to avoid damage to the lip seals.

9. Thoroughly clean the half-shaft and visually inspect the shaft bearing bores and trunnion pin for signs of damage, cracks or surface flaws.

10. Inspect the ball and trunnion joint seal for serviceability; if necessary it should be renewed.

Ball and trunnion joint seal—To renew

If a ball and trunnion joint seal requires renewal, the half-shaft and trunnion assembly must be removed from the car.

1. Carry out Operations 1 to 4 inclusive of 'Half-shaft—To remove'.

2. Remove the trunnion buttons, adjusting washers, rollers and retainers from the trunnion pin as described previously, under 'Half-shaft—To dismantle'.

3. The trunnion pin must be pressed out using pressing equipment capable of exerting a pressure of up to 15 ton/sq. in.

Heat must not be used for this operation.

4. Remove the pin and remove the joint seal.

5. Fit a new seal to the shaft and press the trunnion pin into position.

The trunnion pin must be pressed in squarely and the length of pin which protrudes from each side of the shaft must be equal to within 0.006 in. (0.152 mm.).

If the original pin and the bore are in good condition and the minimum pressing load of 2½ ton/sq. in. can be achieved, the original pin may be used again, if not it is recommended that a new trunnion pin is fitted.

6. After renewing the seal the half-shaft should be assembled as instructed under 'Half-shaft—To assemble'.

Half-shaft—To assemble

The half-shaft should be assembled by reversing the procedure given for dismantling, noting the following points.

1. Thoroughly clean all components before assembly.

2. When assembling the Hardy Spicer universal joint onto the half-shaft, the needle roller bearings should be fitted in the retainers and smeared with Retinax A grease (see under 'Hardy Spicer joint—To fit').

Note It is important not to pack too much grease on the rollers or in the retainers as this could result in damage to the lip seals on assembly.

3. Assemble the trunnion bearings, and buttons onto the trunnion pin, but at this stage do not fit the adjusting washers under the trunnion button heads.

4. Using a micrometer, carefully measure the dimension over the trunnion buttons.

5. Measure the dimension between the outer circumferences of the two outer bores in the joint housing in which the buttons locate.

6. The difference between these two dimensions gives the amount which must be taken up by adjustment, but it is **essential** that this figure is divided by two and washers of equal thickness fitted under each button.

7. The adjustment should be carried out by fitting shim washers under the trunnion buttons to obtain a fit of 0.0005 in. (0.013 mm.) tight to 0.0005 in. (0.013 mm.) slack in the joint housing.

Shim washers are available for this purpose in a range from 0.012 in. to 0.023 in. (0.304 mm. to 0.584 mm.) in 0.001 in. (0.025 mm.) increments.

8. Fit the correctly adjusted trunnion assembly into the joint body then ease the neoprene seal over the body and tighten the two seal clips, ensuring that the small end of the seal is located correctly on to the machined diameter of the half-shaft.

Note When the half-shaft has been fitted to the car the seal should be inspected, whilst the car is at its normal standing height, to ensure that the seal convolutions are not 'crimped' or strained. If they are, the position of the seal on the half-shaft should be adjusted slightly to correct this.

9. Remove the drain plug from the joint housing and inject 150 c.c. of S.A.E. 90 EP oil into the joint and refit the plug.

10. Fit the half-shaft as instructed under 'Half-shaft—To fit'.

Half-shaft—To fit

Fit the half-shaft by reversing the procedure given for removal, noting the following points.

1. If an exchange shaft is being fitted, this is supplied suitably blanked and protected. Remove the protective covering from the joint body splines and also remove the cover on the breather hole in the end of the splined shaft.

All traces of protective material must be removed.

2. Remove the drain plug from the joint body and inject 150 c.c. of S.A.E. 90 EP oil into the joint; fit the plug.

3. Remove the circlip and washer from behind the bearing housing on the old shaft and fit the housing, washer and circlip to the new shaft.

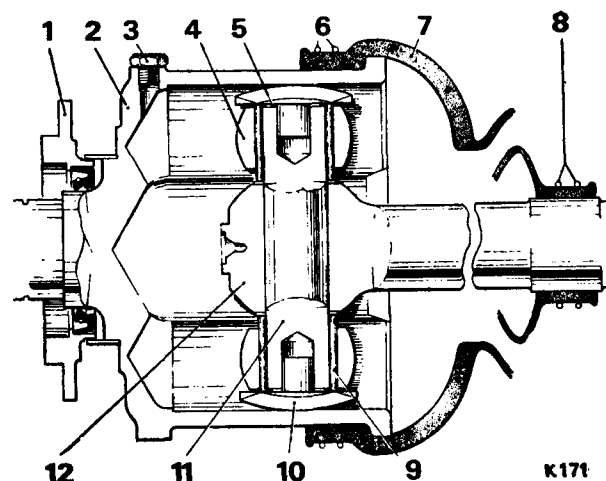

FIG. J15 HALF-SHAFT BALL AND TRUNNION JOINT

- 1 Final drive side housing
- 2 Ball and trunnion joint body
- 3 Drain plug
- 4 Needle roller race
- 5 Adjusting washer
- 6 Seal clip
- 7 Joint seal
- 8 Seal clip
- 9 Needle rollers
- 10 Trunnion button
- 11 Trunnion pin
- 12 Half-shaft knuckle end

Chapter J

4. Fit the new shaft to the car noting that, if it is a right-hand (off-side) half-shaft, care must be taken when entering the housing and splined shaft to ensure that the belleville washers and distance piece are not dislodged and that they are located correctly (see Fig. J9).

5. The housing which fits on the side of the final drive casing has one off-set hole and can be fitted one way only. Therefore, the holes should be aligned as the housing is offered up.

6. Care should be taken when fitting the outer universal joint to the hubs to ensure that the joint is located correctly and the caps fitted correctly.

Note It is essential that the bearing retaining strap is located correctly in the slot provided for it in the bearing cap.

7. Torque tighten all bolts and nuts in accordance with the standard figures given in Chapter P.

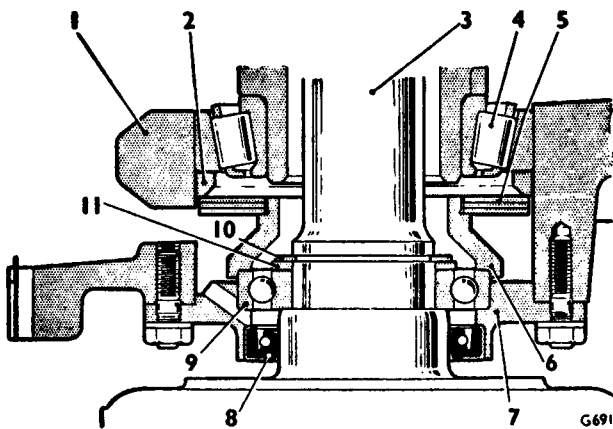

FIG. J16 CROSS-SECTION—FINAL DRIVE SIDE HOUSING

- 1 Differential housing bearing cap
- 2 Adjusting washer—Belleville washers
- 3 Ball and trunnion joint splined shaft
- 4 Taper roller bearing
- 5 Belleville washers
- 6 Distance piece—Belleville washers
- 7 Final drive side housing
- 8 Ball and trunnion joint shaft oil seal
- 9 Ball and trunnion joint shaft bearing
- 10 Retaining circlip
- 11 Retaining washer

Hardy Spicer joint—To remove

Should the need arise in Service to renew a Hardy Spicer joint proceed as follows.

1. Place the car on a ramp and securely chock the road wheels.
2. Disconnect the battery, located in the boot.
3. Remove the complete half-shaft assembly as described under 'Half-shaft—To remove', Operations 1 to 6 inclusive.
4. Remove any paint or dirt from around the circlips in the Hardy Spicer yoke eyes and, using circlip pliers, remove the circlips.
5. Hold the shaft carefully, so that both ends are supported and excessive strain is not put on the convoluted seal, and using a hide mallet, shock drive the races from the yoke eyes.

Hardy Spicer joint—To fit

Fit a Hardy Spicer universal joint by reversing the procedure given for removal.

1. Ensure that the bores in the yoke are clean and in good condition, and lightly grease the rollers after locating them in the retainers. Each bearing retainer is fitted with 38 roller bearings.
2. Fit the cross-piece, minus the retainers and roller bearing assemblies, hold the cross-piece central, and push the roller bearing retainers into the yoke bores just far enough to enable the circlip retainers to be fitted.
3. Fit the circlips.
4. Fit the half-shaft to the car as described under 'Half-shaft—To fit'.
5. Grease the Hardy Spicer joint at the nipple provided.

Note If the Hardy Spicer joint is of the early type without a grease nipple fitted, remove the small plug and fit a normal, straight ball-ended type nipple with a 0.125 in. (3.18 mm.) B.S.P. thread.

Output shaft oil seal—To renew

The oil seals on the ball and trunnion joint shaft are located in the housings on each side of the final drive unit and can be renewed with the final drive unit in position.

1. Remove the complete half-shaft assembly as described previously, carrying out Operations 1 to 6

Chapter J

inclusive, of 'Half-shaft—To remove'. If it is a right-hand half-shaft which is being removed, care should be taken to ensure that the Belleville washers, located behind the right-hand housing, do not drop into the final drive casing.

2. Remove the circlip and washers located on the ball and trunnion joint shaft behind the housing and bearing and remove the housing from the shaft.

3. Remove the seal from the housing.

4. Fit a new seal, ensuring that it is fitted squarely in its locating bore and with the seal lip pointing inward, away from the half-shaft.

5. Fit the housing to the shaft; place the washer in position behind the bearing and fit the circlip, ensuring that it is correctly located in the groove (see Fig. J16).

6. Fit the half-shaft assembly as described previously, carrying out Operations 1 to 7 inclusive, of 'Half-shaft—To fit'

Output shaft bearing—To renew

The output shaft bearing, located in the housing on each side of the final drive unit should be renewed as follows.

1. Remove the half-shaft assembly from the car as described previously, carrying out Operations 1 to 6 inclusive, of 'Half-shaft—To remove'.

2. Remove the circlip and washer from the ball and trunnion joint shaft and remove the housing from the shaft.

3. Left-hand housings have a circlip fitted in the housing to retain the bearing. Remove this circlip.

4. Remove the bearing from the housing using a mandrel or drift; take care not to damage the oil seal.

5. Clean and inspect the housing bore and lightly stone out any marks or burrs.

6. Fit a new bearing ensuring that it is fitted squarely and up to its abutment face (see Fig. J16).

7. If it is a left-hand housing, fit the circlip and locate it correctly in the groove in the housing.

8. Fit the housing to the ball and trunnion joint shaft, fit the washer and circlip.

9. Fit the half-shaft assembly to the car as described previously, carrying out Operations 1 to 7 inclusive, of 'Half-shaft—To fit'.

Section J3

THE FINAL DRIVE CROSS-MEMBER

Overhaul

Printed in England/TVP LTD.

September 1968

T.S.D. 2476

Final drive cross-member—To remove

Normally, the final drive cross-member should not require removal but, should the necessity arise, remove it as follows.

1. Follow the procedure laid down under 'Final drive unit—To remove', carrying out Operations 1 to 10 inclusive.

2. Unscrew and remove the two large nuts and heavy duty washers from the cross-member mount centre bolts and lower the cross-member from the car.

Note It may be necessary to lift the carpet in the boot floor and hold the bolt heads whilst removing the nuts.

If the final drive unit is not to be separated from the cross-member they may be removed together as a unit.

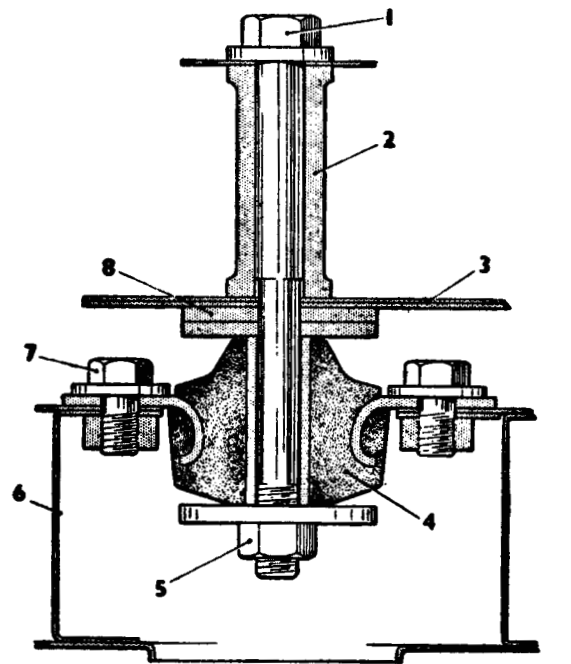

G 613

FIG. J17 FINAL DRIVE CROSS-MEMBER MOUNT**Final drive cross-member mount—To remove**

1. To remove a final drive cross-member mount, remove the cross-member as described previously, or detach and lower the cross-member at least 6 in. (15,24 cm.).

2. Remove the two setscrews securing the mount support plate to the upper face of the cross-member then lift the mount from its location (*see Fig. J17*).

- 1 Mount securing bolt
- 2 Distance tube
- 3 Body member
- 4 Cross-member mount
- 5 Securing nut and washer
- 6 Final drive cross-member
- 7 Mount securing bolts
- 8 Heavy duty washers

Chapter J

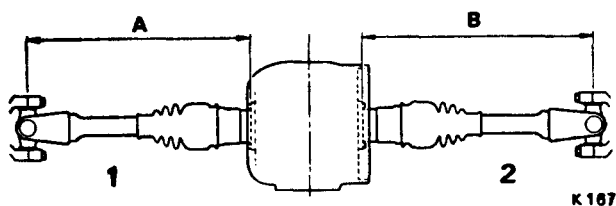

FIG. J18 FINAL DRIVE POSITION CHECK

- 1 Left-hand half-shaft
- 2 Right-hand half-shaft
- A Smaller dimension
- B Greater dimension

Final drive cross-member mount—To fit

Fit the cross-member mount, reversing the procedure given for removal.

1. Torque tighten the two securing setscrews in accordance with the standard figures, relative to size, given in Chapter P.

Final drive cross-member—To fit

Fit the final drive cross-member, reversing the procedure given for removal.

1. Torque tighten the nuts on the mount centre bolts (see Chapter P for standard figures) and whilst tightening the mounts, check from underneath to ensure that the mounts are centrally positioned to the hole in the cross-member.

2. Fit the final drive unit as instructed under 'Final drive unit—To fit', carrying out Operations 1 to 8, with the exception of Operation 4, the half-shafts being left disconnected from the yokes but supported.

3. With the final drive unit fitted to the cross-member, a check must now be made to ensure that the final drive is centrally positioned.

4. Measure from the face of the hub yoke, on which the universal joint bearing cap fits, to the face of the final drive side housing on each side of the car (see Fig. J18).

Note These measurements should be taken rear of the half-shaft line as they are difficult to take from the front of the axle.

The dimension obtained between the right-hand hub and right-hand side housing should be 0.175 in. (4.44 mm.) greater than the dimension obtained on the left-hand side, as viewed from the rear of the car.

5. If the final drive position is not correct, slacken the nuts securing the mount and move the cross-member in the appropriate direction.

This is best accomplished by gently levering the cross-member whilst at the same time tapping the heads of the mount centre bolts. Access to the bolt heads is gained by lifting the carpet on the floor of the boot.

It must be stressed that if Operation 5 is performed, extreme care must be taken to ensure that the cross-member mounts are still central to the hole in the cross-member before finally tightening the nuts.

6. Connect the half-shafts to the hub yokes.

Section J4

REAR HUBS, STUB AXLES AND DRIVE-SHAFTS

Overhaul

Rear hub bearings—To renew Hub unit—To remove

1. Position the car on a ramp and securely chock the front wheels.
2. Disconnect the battery, located in the boot.
3. Remove the wheel disc and loosen but do not remove the wheel nuts.
4. Using a hydraulic jack with an extension piece and a hardwood block positioned beneath the final drive differential casing, raise the rear of the car until the wheels just clear the ramp.
5. Position blocks and the sill beams (RH 7820) beneath the body sills. Place screw jacks beneath the trailing arms of the car.
6. Lower the hydraulic jack from beneath the final drive differential casing allowing the car to rest on the sill beams and supports.
7. Remove the rear road wheels and place supports beneath the brake discs.
8. Disconnect the handbrake linkage from the brake calipers (see Chapter G—Hydraulics for method and special precautions to be taken).
9. Remove the setscrews which secure the bearing caps to the yoke at the half-shaft universal joint. Separate the universal joint from the hub yoke by moving the half-shaft inward towards the final drive differential unit i.e. moving the ball and trunnion joint further into its housing.

10. Using a length of strong cord or covered wire, secure the half-shaft to the final drive cross-member. This will prevent possible damage to the shaft when the hub unit is removed.

11. Steady the hub unit then remove the setscrews securing the stub axle flange to the trailing arm. Note the position and length of each setscrew to facilitate assembly. Collect the brake linkage bracket which is secured by two of the setscrews.

12. Remove the hub unit from the car.

Hub unit—To dismantle

1. Remove the setscrews securing the brake calipers to the hub axle flange; remove the calipers.
2. Remove the large nut securing the yoke to the drive-shaft.
3. Using the extractor beam (RH 8016), in conjunction with the hydraulic ram (RH 8017) and extractor bolt (RH 8018), remove the yoke from the tapered drive-shaft and collect the key.
4. Remove the setscrews securing the outer end of the drive-shaft to the hub. Withdraw the drive-shaft from the hollow stub axle.
5. Unlock and remove the shrouded nut, and remove the key washer from the stub axle.
Remove the hub, complete with bearings, from the stub axle; collect the chamfered distance piece.

Chapter J

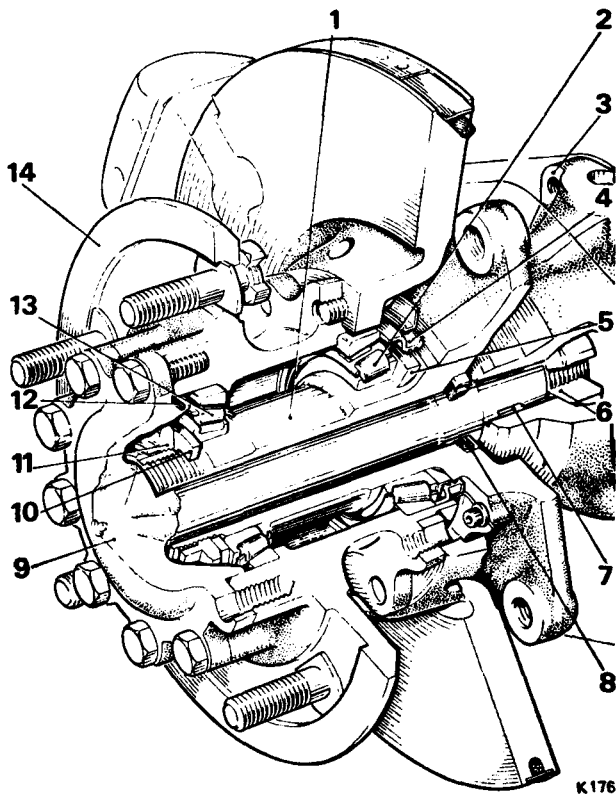

FIG. J19 CUT-AWAY VIEW OF REAR HUB, STUB AXLE AND DRIVE-SHAFT

- 1 Hollow stub axle
- 2 Inner taper roller bearing
- 3 Yoke
- 4 Acme threaded seal
- 5 Distance piece
- 6 Nut
- 7 Key
- 8 Felt seal with retainer
- 9 Drive-shaft
- 10 Keyed adjusting washer
- 11 Shrouded nut
- 12 Seal
- 13 Outer taper roller bearing
- 14 Hub

6. Remove the outer bearing inner race. Using a soft metal drift, drive out the inner bearing together with the grease retainer.

7. Drive out the outer bearing.

8. Remove the felt seal and retainer from the stub axle counterbore.

9. With the hub dismantled, inspect the disc brakes and the pads of the rear brake calipers for wear or damage. Ensure that the brake disc securing setscrews are correctly torque tightened to standard figures as given in Chapter P. If a brake disc is to be removed, refer to Chapter G—Hydraulics.

10. Thoroughly clean all hub components which are to be fitted.

Hub unit—To assemble

1. Collect all cleaned parts to be assembled together with any new or replacement parts.

2. Press new bearing outer races into the hub, smaller end of the taper bore leading, and ensure that the leading faces abut the shoulders of the hub counterbore.

3. Pack the hub with approximately 2 oz. (71 gm.) of the approved grease; the grease must be smeared on the inner wall of the hub so that it will not be disturbed when the hub is fitted to the stub axle.

4. Lubricate the new inner races with the approved grease and fit them to their respective outer races.

5. Fit the hub inner bearing inner race, press the Acme threaded grease retainer into position; the leading edge must abut the bearing outer race.

Note When renewing the bearing of more than one hub at the same time, always retain the inner race and roller cage, together with the outer race as supplied in the Manufacturer's sealed package. The inner and outer races are matched sets, and should not be fitted separately.

It should also be noted that the grease retainers are marked 'L.H.—N.S.' and 'R.H.—O.S.' dependent upon the side of the car to which they are fitted.

6. Fit the distance piece, chamfered edge leading, on to the stub axle to abut the shoulder.

Hub unit—To fit

1. Position the hub on the stub axle and fit the hardened key washer and a new shrouded nut.

2. Tighten the nut just sufficiently to remove any bearing end float, then, using a dial test indicator mounted adjacent to the brake disc, measure the run-out of the disc at the maximum possible radius.

Run-out must not exceed 0.007 in. (0.178 mm.) total indicator reading as this is a measure of the stack tolerance of all the components. If the run-out exceeds

Chapter J

this figure, it will be necessary to dismantle the hub and brake disc to investigate the cause of the run-out.

3. After checking the run-out, slacken the shrouded nut, then, using a feeler gauge placed between the outer bearing and key washer, to give between 0.002 in. (0,05 mm.) and 0.004 in. (0,10 mm.) bearing end float, tighten the nut sufficiently to grip the feeler gauge lightly.

Alternatively, use suitable dial test indicator equipment secured to the stub axle to obtain the required end float.

Continuous rotation of the hub is essential during this operation to ensure that the taper rollers seat correctly in the outer races.

4. Peen the shroud of the nut to locate in the grooves of the stub axle; remove the feeler gauge or alternative dial test equipment.

Note Incorrect setting, exerting a load on the bearing or giving excess end float, will promote premature bearing wear.

The remaining operations for fitting the rear hub unit are a careful reversal of the procedure given for its removal and dismantling, noting the following points.

5. Fit a new rubber 'O' ring onto the drive-shaft applying a small amount of grease to the ring before fitting it.

6. Fit a new felt seal and retainer into the stub axle. Apply a small amount of grease to the felt seal.

7. Fit the key to the drive-shaft taper and torque tighten the yoke retaining nut using the torque spanner (RH 8014) and socket (RH 8026).

Note Cars produced prior to car numbers SRX 1916—Standard cars, and CRX 1937—Coachbuilt cars, require the yoke retaining nut to be tightened to between 450 lb. ft. and 475 lb. ft. (62,21 kgm. and 65,66 kgm.). Cars produced after the above numbers require the yoke retaining nut to be tightened to between 500 lb. ft. and 525 lb. ft. (69,40 kgm. and 72,58 kgm.).

The increased torque figure applies only to the cars following the numbers quoted and on no account should the yoke retaining nuts on earlier cars be tightened to the increased torque figure.

8. When connecting the half-shaft universal joint to the hub unit yoke ensure that the joint seats correctly in the yoke and that the bearing cap setscrews are torque tightened in position.

9. When connecting the brake linkage and brake feed pipes, refer to Chapter G—Hydraulics, for special precautions to be taken.

10. Fit the road wheel and remove the supports from beneath the body and trailing arms by jacking up the car beneath the final drive differential casing.

11. Lower the jack, tighten the wheel nuts and fit the wheel disc.

Section J5

DIMENSIONAL DATA

FINAL DRIVE UNIT	
Backlash—pinion to crown wheel	Etched on crown wheel
Backlash—differential housing pinions	Nil
End float—differential housing pinions	Nil
Crown wheel run-out (maximum)	0.002 in. (0,05 mm.)
Differential housing—trunnion diameters	0.7497 in.—0.750 in. (19,036 mm.—19,05 mm.)
Differential housing pinions—bore diameters	0.7505 in.—0.751 in. (19,05 mm.—19,075 mm.)
Differential housing and end cap—bearing locating diameters	2.002 in.—2.0025 in. (50,85 mm.—50,863 mm.) 2.62725 in.—2.6275 in. (66,732 mm.—66,738 mm.)
Differential housing bearings—bore diameters	2.000 in.—2.0005 in. (50,8 mm.—50,812 mm.) 2.625 in.—2.6255 in. (66,675 mm.—66,687 mm.)
Differential housing bearings—outside diameters	3.500 in.—3.501 in. (88,9 mm.—88,925 mm.) 4.250 in.—4.251 in. (107,950 mm.—107,975 mm.)
Final drive casing—differential housing bearing locating bores	3.501 in.—3.5015 in. (88,925 mm.—88,938 mm.) 4.251 in.—4.252 in. (107,975 mm.—108,0 mm.)
Final drive casing—pinion housing locating diameters	4.150 in.—4.1505 in. (105,410 mm.—105,422 mm.) 4.162 in.—4.1625 in. (105,715 mm.—105,73 mm.)
Pinion housing—locating diameters	4.1525 in.—4.153 in. (105,473 mm.—105,486 mm.) 4.164 in.—4.1645 in. (105,765 mm.—105,778 mm.)
Pinion shaft—bearing locating diameters	1.37625 in.—1.3765 in. (34,956 mm.—34,963 mm.) 1.75125 in.—1.7515 in. (44,581 mm.—44,588 mm.)
Pinion bearings—bore diameters	1.375 in.—1.3755 in. (34,925 mm.—34,937 mm.) 1.750 in.—1.7505 in. (44,450 mm.—44,462 mm.)
Pinion housing—pinion bearing locating diameters	2.8423 in.—2.8433 in. (72,294 mm.—72,319 mm.) 3.748 in.—3.749 in. (95,199 mm.—95,224 mm.)

Pinion bearings—outside diameters	2.8438 in.—2.8448 in. (72,232 mm.—72,257 mm.) 3.750 in.—3.751 in. (95,250 mm.—95,275 mm.)
Pinion—splined diameter	1.5988 in.—1.602 in. (40,609 mm.—40,690 mm.) over 0.1575 in. (4,000 mm.) dia. rollers
Pinion—nose bearing locating diameter	1.5167 in.—1.5172 in. (38,524 mm.—38,534 mm.)
Final drive casing—pinion nose bearing bore diameter	2.4402 in.—2.4407 in. (61,981 mm.—61,993 mm.)
Pinion nose bearing—outside diameter	2.44045 in.—2.44095 in. (61,997 mm.—61,999 mm.)
Pinion nose bearing—running clearance	0.0005 in.—0.0015 in. (0,027 mm.—0,038 mm.)
FINAL DRIVE HALF-SHAFTS	
Side housing—bearing locating bore	2.6242 in.—2.62445 in. (66,649 mm.—66,672 mm.)
Bearing—side housing—outside diameter	2.6240 in.—2.6245 in. (67,056 mm.—67,068 mm.)
Bearing—side housing—bore diameter	1.4997 in.—1.5002 in. (37,863 mm.—38,105 mm.)
Ball and trunnion joint shaft—bearing diameter	1.49975 in.—1.500 in. (38,093 mm.—38,10 mm.)
Ball and trunnion joint—trunnion pin bore	0.9751 in.—0.9754 in. (24,767 mm.—24,775 mm.)
Ball and trunnion joint—trunnion pin diameter	0.97745 in.—0.97765 in. (24,838 mm.—24,889 mm.)
Trunnion pin—minimum pressing load	2½ tons/sq. in.
Ball and trunnion joint—spherical ball diameter	1.7490 in.—1.7495 in. (44,424 mm.—44,437 mm.)
Ball and trunnion joint—spherical ball bore	1.2135 in.—1.2140 in. (30,832 mm.—30,835 mm.)
Needle rollers (29 off)—diameter	0.1180 in.—0.1182 in. (2,997 mm.—3,002 mm.)
Ball and trunnion joint—spherical ball locating bores	1.750 in.—1.751 in. (44,450 mm.—44,475 mm.)

Section J6

WORKSHOP TOOLS

Tool Number	Description
RH 7861	Pre-loading jig—Belleville washers—Final drive R.H. side housing
RH 7862	Locking tool—Pinion flange
RH 7863	Extractor—Bevel pinion bearing
RH 8014	Torque wrench—0 lb. ft. to 600 lb. ft.—Hub yoke nut
RH 8016	Extractor beam When used in conjunction with RH 8017 and RH 8018 will extract the tapered yoke from the hub drive-shaft. When used in conjunction with RH 8017, RH 8020, RH 8021 and RH 8022 the extractor beam can be used to remove the rear tapered roller bearing from the final drive pinion.
RH 8017	Hydraulic ram To be used in conjunction with RH 8016, RH 8018, RH 8020, RH 8021 and RH 8022 as detailed above. When used in conjunction with extractor beam RH 8033 will extract the final drive flange from the pinion.
RH 8018	Extractor bolt 2 See RH 8017 for uses.
RH 8020	Separator See RH 8017 for uses.
RH 8021	Extractor bolt 2 See RH 8017 for uses.
RH 8022	Pressure pad See RH 8017 for uses.
RH 8026	Socket head $1\frac{1}{8}$ in. A/F To be used in conjunction with RH 8014.
RH 8032	Stiffening bar—Final drive casing
RH 8033	Extractor beam See RH 8017 for uses.