

Chapter N

POWER ASSISTED STEERING SYSTEM

| SECTION | PAGE |
|--|-------------|
| N1 The Steering Column (Early Cars) | N1 |
| N2 The Steering Column (Later Cars) | N9 |
| N3 Steering Pump (Hobourn Eaton) and Hoses | N13 |
| N4 Steering Pump (Saginaw) Fluid Cooler and Hoses | N19 |
| N5 The Steering Box | N31 |
| N6 The Steering Linkage | N43 |
| N7 Fault Diagnosis Chart | N49 |

**Fig. N1 Cut-away view of steering box—all cars—and
steering column—early cars**

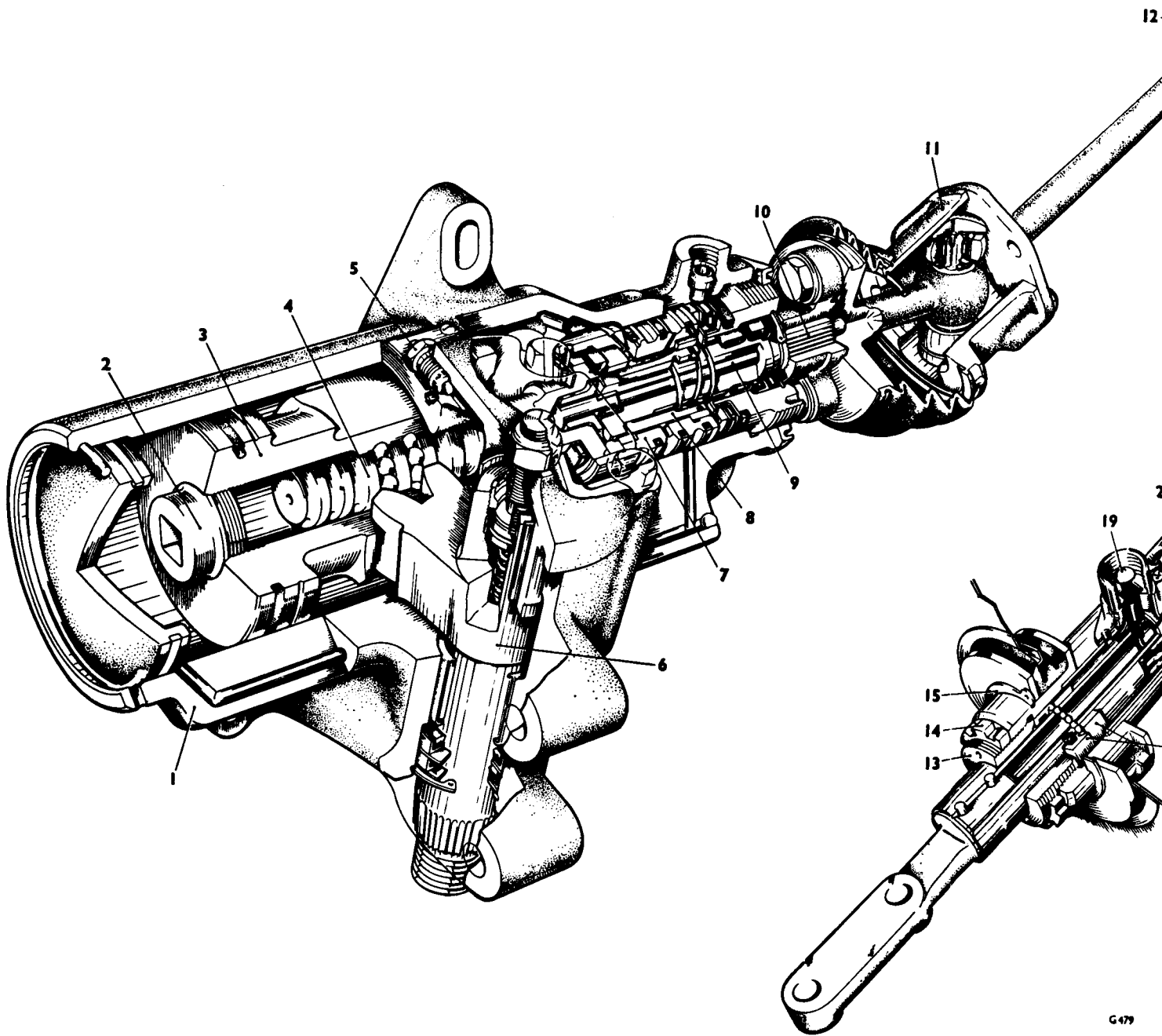

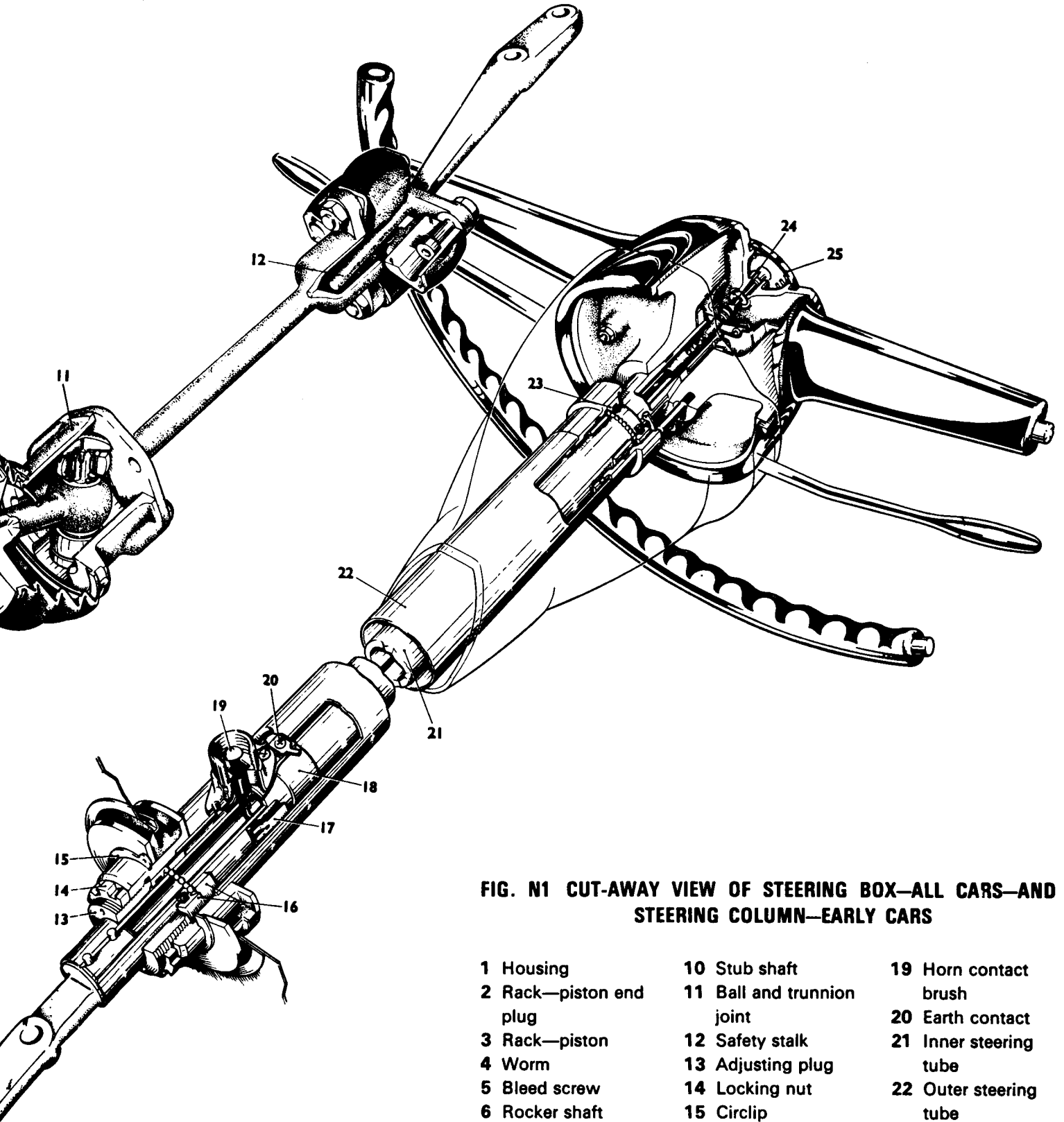

FIG. N1 CUT-AWAY VIEW OF STEERING BOX—ALL CARS—AND STEERING COLUMN—EARLY CARS

- | | | |
|------------------------|----------------------------|------------------------|
| 1 Housing | 10 Stub shaft | 19 Horn contact brush |
| 2 Rack—piston end plug | 11 Ball and trunnion joint | 20 Earth contact |
| 3 Rack—piston | 12 Safety stalk | 21 Inner steering tube |
| 4 Worm | 13 Adjusting plug | 22 Outer steering tube |
| 5 Bleed screw | 14 Locking nut | 23 Inner race |
| 6 Rocker shaft | 15 Circlip | 24 Horn contact |
| 7 Valve body | 16 Inner race | 25 Horn button |
| 8 Valve spool | 17 Horn slip ring | |
| 9 Torsion bar | 18 Earth slip ring | |

Chapter N

POWER ASSISTED STEERING SYSTEM

Section N1

THE STEERING COLUMN (early cars) (cars prior to number SRX 6001)

Overhaul

Lower steering column—To remove

The lower steering column is removed from underneath the car.

1. Place the car on a ramp then unscrew and remove the two bolts and nuts from the in-line joint located below the toe-board.
2. Remove the pinch bolt from the splined clamp connecting the column to the steering box input shaft and ease the clamp off the shaft splines.
3. Remove the lower column from the car, taking care not to extend the lower joint otherwise its internal components will come apart.

Lower steering column universal joint— To dismantle

Remove the lower steering column from the car as described previously under 'Lower steering column—To remove'.

1. Mark the splined clamp and universal joint body with correlation marks to ensure that on assembly, the same relative positions are maintained.
2. Slacken and remove the clips from either end of the convoluted boot.

3. Ease both ends of the convoluted boot from their location on the joint body and the knuckle end piece.

4. Holding the boot away from the joint and using a small screwdriver remove the circlip from the universal joint and ease the ball and trunnion assembly out of the housing. Alternatively deflect the joint, as far as possible parallel to the cross-pin then carefully pull apart over the circlip which need not be removed.

Note To prevent the bearing and retainers from disintegrating, the housing must be held so that the trunnion pin assembly is horizontal as it is removed.

5. Remove the convoluted boot, carefully easing it over the trunnion buttons.

6. Remove the trunnion buttons, belleville washers, bearings, retainers and thrust washers from the trunnion pin. The individual bearing and button assemblies should be retained together as assemblies and it should be noted from which side of the trunnion pin each was removed.

Lower steering column universal joint— To inspect

1. Wash all components in paraffin and dry them prior to inspection. Inspect the bores of the housing

Chapter N

for signs of wear, pitting or damage. The diameter of the two outer button location bores should be 1.000 in. to 1.001 in. (2,54 cm. to 2,542 cm.).

2. The trunnion button and bearing retainers should be smooth and free from surface defects. The inside and outside diameters of the retainers should be 0.3937 in. and 0.5512 in. (0,998 cm. and 1,40 cm.) respectively.

3. The roller bearing and the trunnion pin surface should be smooth and free from defects. The diameter of the rollers is 0.999 in. to 0.9995 in. (2,5374 cm. to 2,5375 cm.) and the trunnion pin diameter at the bearing areas is 0.39345 in. to 0.3937 in. (0,9983 cm. to 0,9984 cm.).

4. The Belleville washer should be free from cracks or distortions. It should have a minimum free height of 0.016 in. (0,041 cm.).

5. The trunnion pin should be inspected for position with a depth micrometer or by placing the knuckle end between centres and checking the pin ends with a dial test indicator. The pin should be within 0.006 in. (0,0152 cm.) of the centre line of the knuckle end piece.

6. If the trunnion pin position is inspected by using a dial test indicator with the knuckle piece between centres, it will be necessary to remove the splined clamp from the end of the knuckle. The two setscrews which secure the clamp lie in slotted holes in the splined coupling flange which provides a small degree of fine adjustment when steering wheel centralisation is being carried out. It is therefore advisable to mark the coupling with correlation marks before disconnecting it to facilitate fitting it in the same relative position on assembly.

7. In the unlikely event of the trunnion pin requiring replacement, it must be pressed out and a new one pressed in squarely to conform with the above information, on central position.

Note Heat should not be applied to remove or fit a trunnion pin.

The interference between the trunnion pin and knuckle is 0.003 in. (0,076 mm.).

**Steering column universal joint—
To assemble**

To assemble the steering column universal joint reverse the procedure given for its dismantling, noting the following points.

1. The alignment marks previously made on the body and joint housing should be lined up before entering the pin and bearing assembly.

2. On assembly, the trunnion bearings, housing bores and buttons should be lubricated with a liberal application of Retinax 'A' grease, and care should be taken to ensure that the circlip and sealing boot are fitted and located correctly. New clips must be used to attach the boot and must hold it tightly.

3. If the splined coupling has been disconnected from the knuckle piece it must be replaced in its correct position according to the correlation marks made before dismantling.

**Lower steering column bonded coupling—
To renew**

Remove the lower steering column from the car as previously described under 'Lower steering column—To remove'.

1. Mark the steering column on both sides of the bonded coupling to ensure that the wheel position remains unchanged on assembly.

2. Remove the four socket-headed setscrews and nuts from the bonded coupling, withdraw the safety stalk and remove the coupling.

3. Fit a new bonded coupling reversing the procedure given for its removal, noting that the marks made on each half of the column should be lined up and the nuts on the socket-headed screws should be torque tightened to between 16 lb. ft. and 18 lb. ft. (2,21 kg.m. to 2,48 kg.m.).

Lower steering column—To fit

To fit the lower steering column reverse the procedure given for its removal, noting the following points.

1. It will be noted that the splined clamp has a flat machined in the splined bore which corresponds with a flat machined on the steering box input shaft. This ensures that the steering wheel position remains unchanged, provided that the clamp has not been disconnected from the universal joint. If the clamp has been disconnected from the universal joint, the wheel must be set relative to the steering box (see Steering wheel—To set).

2. The two bolts and nuts securing the joint at the toe-board should be torque tightened to between 16 lb. ft. and 18 lb. ft. (2,21 kg.m. and 2,48 kg.m.) and the splined clamp pinch bolt torque tightened to between 16 lb. ft. and 18 lb. ft. (2,21 kg.m. and 2,48 kg.m.).

Chapter N

Steering wheel—To remove

1. Remove the gear selector cowling, which is in two pieces, by unscrewing and removing the six Phillips setscrews located in the cowl lower half; the upper section of the cowl is secured by the four outer setscrews and the lower section by the remaining two setscrews.

2. Unscrew the three nuts located behind the steering wheel and remove the horn button assembly from the steering wheel centre.

3. Withdraw the horn contact plate and disconnect the electrical plug.

4. Unlock the tab washer then unscrew and remove the nut which secures the steering wheel to the column.

5. Before removing the wheel, the centre of the column and the steering wheel inner boss face should be suitably marked to ensure that the wheel is replaced in the same relative position on assembly.

6. Replace the nut to prevent possible damage to the threaded end of the column, then, using special tool (RH 7870), extract the wheel. Remove the tool and the wheel securing nut and lift away the wheel.

Horn button assembly—To dismantle

Remove the horn button assembly as described above under 'Steering wheel—To remove'.

1. Depress the button and remove the circlip which secures the button and plunger assembly to the housing.

2. Remove the button and plunger assembly and the return spring.

Horn button assembly—To assemble

1. To assemble the horn button assembly reverse the procedure given for its dismantling ensuring that the return spring and the securing circlip are located correctly. Lightly lubricate the horn button guide stems with Rocol 204G Ragosine or equivalent grease.

Gearchange selector switch—To remove

(see Fig. N2)

1. Disconnect the battery.

2. Remove the screws retaining the upper and lower halves of the cowling. These halves should always be retained as a set. Carefully remove the upper half of the cowling.

3. Remove the two screws retaining the lower half of the cowling to its clamping bracket; remove the lower half of the cowling.

4. Disconnect the indicator lamp.

5. Disconnect the micro-switch(es).

6. Remove the screws securing the switch insulating plate.

7. Remove the gearchange selector.

Gearchange selector switch—To dismantle

1. Remove the screws securing the micro-switch(es) to the rear face of the base assembly and remove the micro-switch(es).

2. Remove the operating arm from the spindle of the quadrant.

3. Remove the single 'Phillips' screw securing the pointer to the quadrant boss and remove the pointer.

Note Care must be taken not to scratch the pointer or the indicator scale.

4. Remove the two 'Phillips' screws and shake-proof washers securing the indicator support bracket to the two bosses on the base assembly, then remove the indicator support bracket assembly.

5. Remove the two hexagon-headed 3 B.A. screws securing the gate assembly to the underside of the base.

6. Remove the circlip, clevis pin and spring securing the gear selector lever to the quadrant, then remove the lever with the gate assembly attached.

7. Remove the two 'Phillips' screws securing the phosphor-bronze contact to the base plate. Retain the two insulating dowels and the two insulating strips.

8. Remove the circlip from the other end of the rocking arm.

9. Remove the rocking arm to quadrant tension springs; remove the rocking arm assembly.

10. Remove the $\frac{1}{4}$ in. U.N.F. nut and washer from the quadrant spindle and remove the quadrant assembly from the base assembly.

Gearchange selector switch—To assemble

1. Fit the quadrant assembly onto the base and nip the $\frac{1}{4}$ in. U.N.F. nut and washer onto the spindle. Check that the quadrant is free to rotate.

Chapter N

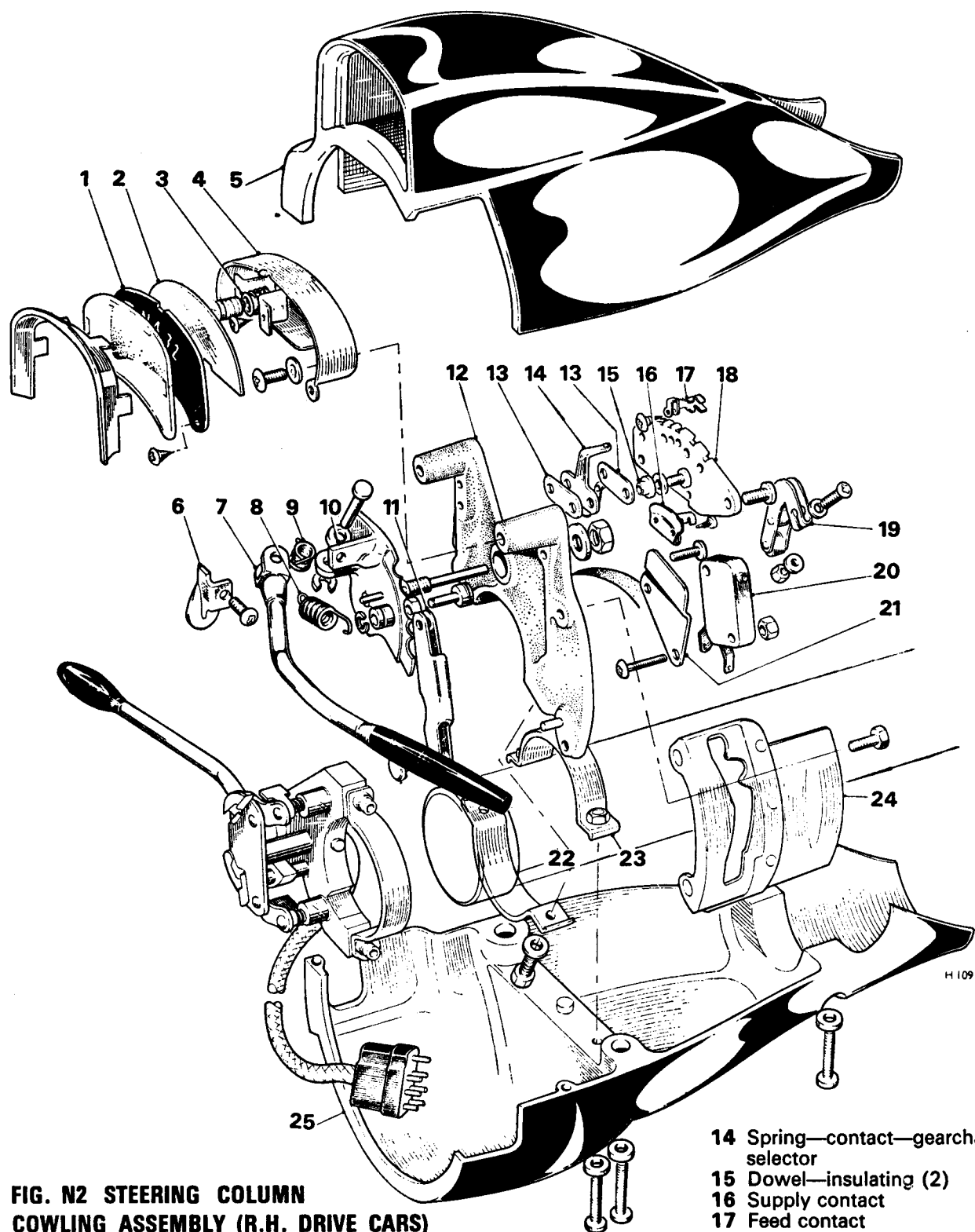

FIG. N2 STEERING COLUMN COWLING ASSEMBLY (R.H. DRIVE CARS) (REMOTE GEARCHANGE AND DIRECTION INDICATOR MECHANISMS)

- 1 Indicator scale
- 2 Filter—indicator lamp
- 3 Bulb holder
- 4 Bracket—indicator support
- 5 Cowl halves—upper and lower
- 6 Pointer—gearchange selector
- 7 Lever—assembly—gear selector

- 8 Spring—tension—rocking arm
- 9 Spring—lever—gear selector
- 10 Quadrant assembly—5 position
- 11 Rocking arm
- 12 Base assembly—gear selector
- 13 Insulating strips (2)

- 14 Spring—contact—gearchange selector
- 15 Dowel—insulating (2)
- 16 Supply contact
- 17 Feed contact
- 18 Plate insulating—5 position
- 19 Operating arm—reversing lamp
- 20 Micro-switch
- 21 Bracket micro-switch mounting
- 22 Clamp—gearchange selector base
- 23 Clamp—cowl to steering column
- 24 Bracket—support assembly—5 position

Chapter N

2. Remove the quadrant and lubricate the spindle with Ragosine 204G or equivalent grease. Refit the quadrant and finally tighten the $\frac{1}{2}$ in. U.N.F. nut.

3. Do not overtighten the nut, since the bearing boss tends to spread slightly and a tight bearing may be formed.

4. Fit the rocking arm assembly, then check to ensure that the roller lines up correctly with the quadrant detent form.

5. Remove the rocking arm and hook the tension spring onto the anchor pin roller on the underside of the quadrant and onto the spring anchor on the underside of the rocking arm.

This operation is made easier by rotating the quadrant anti-clockwise beyond its normal travel, so that the spring is not under tension. Rotate the quadrant clockwise whilst holding the rocking arm clear, then allow the roller to locate on the detent forms. Fit the spring on the top side of the quadrant and rocking arm.

Note Do not fit the retaining clip to the rocking arm at this stage. (They are difficult to remove, should the need arise).

6. Move the quadrant to a mid-way position and fit the phosphor-bronze contact. This contact is assembled between two insulating strips which are located by two insulating dowels. This sandwich assembly is then secured to the quadrant by two screws and washers.

Important Extreme caution must be taken with the moving contact, so that it is not bent or damaged in any way.

7. Before fitting the selector lever assembly carry out the following checks.

Check that the clevis pin will slide through both the fork end on the lever and the holes in the mounting bosses on the quadrant, then check that the fork end will slide between these bosses.

8. Lightly smear Ragosine 204G or equivalent grease on the outside of the fork end, the inside of the bosses, the clevis pin and the clevis pin holes, then locate the fork end in the bosses by the clevis pin and fit the spring inside the fork end and over the clevis pin. Push home the pin and fit the circlip. Check that the lever will return easily under the load of the spring.

9. Secure the gate assembly to the underside of the base by means of the two hexagon-headed 3 B.A. screws.

Check that, when the position of the lever is controlled by the detents, it lines up with the profile of the gate liner and that the extreme positions of the lever are not limited by the gate.

10. Fit the insulating plate complete with the feed and supply contacts fitted to it.

When the unit is screwed down by the three screws, check that the inside leg of the moving contact is pressing onto the supply contact and that at the extremities of its travel the hemispherical head is still making good contact with the supply contact.

11. Each selection should then be made in turn, checking that the outside leg on the moving contact lines up correctly with each of the feed contacts.

12. Mount this assembly on the two bosses on the base by means of the two screws and shake-proof washers.

13. Fit the blue filter with its flattened end in front of the bulb and behind the bracket mounting screw heads. Bend the radiused top end over the bulb and check that it follows the contours of the support bracket.

14. Hold the filter in this position by means of a 0.025 in. (0.64 mm.) feeler gauge held from the front of the unit, fit the indicator scale over the support bracket and secure it with two self-tapping screws. The scale should drop onto the bracket and its lip must not be forced down.

15. Feed the pointer under the indicator scale, then with '3 range' selected use a thin-blade 'Phillips' head screwdriver, to feed the single 5 B.A. screw through the pointer leg and screw it into the quadrant boss. Care should be taken not to scratch either the pointer or the indicator scale.

16. Each selection should then be made and the alignment of the pointer checked.

17. Fit the micro-switch(es) onto the two bosses on the rear face of the base assembly. Fit the operating arm onto the spindle of the quadrant. **On a car not fitted with refrigeration** set the operating arm so that the single micro-switch is depressed when the selection is 'R'. **On a car fitted with refrigeration** the two micro-switches require setting so that the fast-idle micro-switch is depressed just as the selector is engaging 'N'. Check that the 'R' micro-switch is operated satisfactorily.

Note On left-hand drive cars with refrigeration the fast-idle cam is engaged in both N and P positions.

18. Fit the retaining clip to the rocking arm pivot.

19. Lightly smear Ragosine 204G or equivalent grease on the quadrant detents, then operate the switch several times to ensure that the Ragosine is spread evenly.

Chapter N

Gearchange selector switch—To fit

1. Fit the gearchange selector switch onto the steering column taking care to locate the switch dowel in the hole provided.

Note To facilitate assembly it is advisable to place the bottom cowl clamp on the steering column before tightening the selector switch assembly.

2. Connect the insulating pad and contact assembly, the micro-switch(es) and the indicator lamp wiring.

3. Fit the lower half of the cowling onto its clamping bracket then fit the upper half of the cowling.

Note Care must be taken before tightening the cowling retaining screws to ensure that the wiring looms are not trapped between the cowl and cover.

Direction indicator switch—To remove

1. Disconnect the battery.

2. Remove the gearchange selector switch as described previously.

3. Disconnect the wiring loom.

4. Remove the two Allen screws securing the switch clamp to the column; remove the switch.

Direction indicator switch—To fit

1. To fit the direction indicator switch reverse the procedure given for its removal.

Note The indicator switch has a dowel in its base which locates in the steering column tube.

Upper steering column—To remove

1. Remove the steering wheel as previously described under 'Upper steering column—To remove'.

2. Disconnect the battery which is located in the boot.

3. Unscrew and remove the two bolts from the in-line joint situated just below the toe-board in the engine compartment.

4. Remove the circlip from the lower end of the upper column and remove the seal plate.

5. Unplug the steering column wiring looms from the main fuse box.

6. Disconnect the horn contact wires which are located part way up the outer column.

7. Support the steering column and unscrew and remove the two Allen screws securing the steering column support clamp cap; remove the cap and withdraw the column into the car and out through the door aperture.

Note Care should be taken when manoeuvring the steering column inside the saloon to avoid damage to the woodwork and trim, etc.

Upper steering column—To dismantle

1. Remove the steering wheel gearchange selector and direction indicator switch as previously described.

2. Remove the two screws securing the horn contact brush assembly to the column then remove the assembly.

3. Remove the screw securing the earth contact strip to the column then remove the strip.

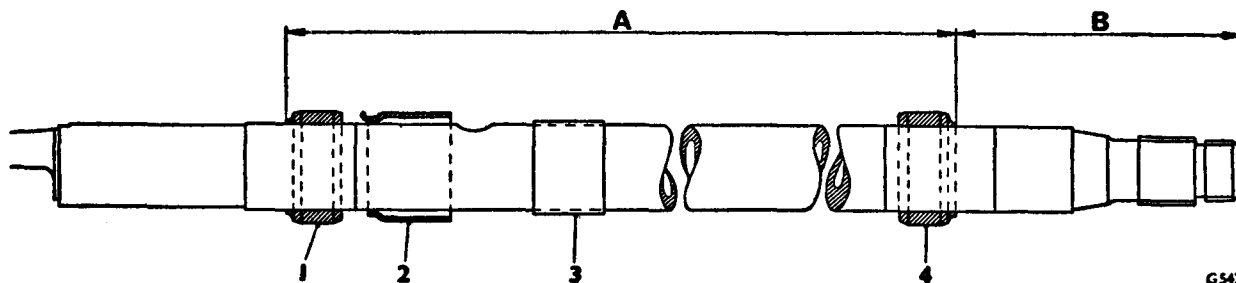

FIG. N3 ASSEMBLY OF INNER STEERING TUBE

1 Inner race

2 Slip ring

3 Earth slip ring

4 Inner race

A 28.525 in. ± 0.005 in. (72.45 cm. ± 0.12 mm.)

B 3.000 in. ± 0.010 in. (7.62 cm. ± 0.25 mm.)

Chapter N

4. Using spanners (RH 7871 and RH 7872), remove the lock-nut and plug from the lower end of the column, then remove the circlip which retains the bearing at the upper end of the column.

5. Holding the column, lower end downwards, gently tap it around the base to jar the lower bearing race from its location within the tube.

6. Care must be taken when this operation is carried out to ensure that as the bearing drops out of the tube the ball bearings do not scatter.

7. When this has been accomplished repeat the operation on the upper bearing, again taking precautions against losing the ball bearings.

Upper steering column thrust races— To renew

Remove the inner column from the outer tube as follows.

1. Discard the felt seals fitted in the thrust races and the seal fitted in the top of the steering column.

2. After the column has been removed and dismantled, remove the bearing races from the inner column after marking their positions with a pencil line.

3. Press the new races into position on the inner column. The races must be positioned to conform with the dimensions given in *Figure N3*; the pencil marks provide a useful guide.

Upper steering column—To assemble

1. Fit a new felt seal into the top of the outer steering tube and into each thrust race.

2. Lubricate the earth contact slip ring with Gulf Elvolube grease or its equivalent.

3. Insert the inner column into the outer tube.

4. Grease the inner races with Rocol T 265 or equivalent grease and place 27 ball bearings in the grease on the bearing track of the upper race; fit the outer race and circlip, then fit the lower balls and race in a similar manner. Using spanner (RH 7871), screw in the end plug until the end float in the column is just taken up, then using spanner (RH 7872), tighten the lock-nut. **Do not** overtighten the end plug or damage to the races will result. Do not lose balls between inner and outer columns.

5. Fit and secure the earth contact strip also the horn button contact brush assembly to the column.

6. Secure the gearchange selector and direction indicator mechanism clamp to the outer column by means of the two setscrews.

7. Fit the steering wheel as outlined under 'Steering wheel—To fit and set'.

Upper steering column—To fit

1. To fit the upper steering column reverse the procedure given for its removal under 'Upper steering column—To remove'.

Steering wheel—To fit and set

1. To fit the steering wheel reverse the procedure given for its removal. Ensure that the correlation marks (see Page N3—'Steering wheel—To remove' Operation 5) on the steering wheel inner boss face and the centre of the column are aligned.

Printed in England

September 1968

T.S.D. 2476

Fig. N4 Cut-away view — energy absorbing steering column and lower linkage

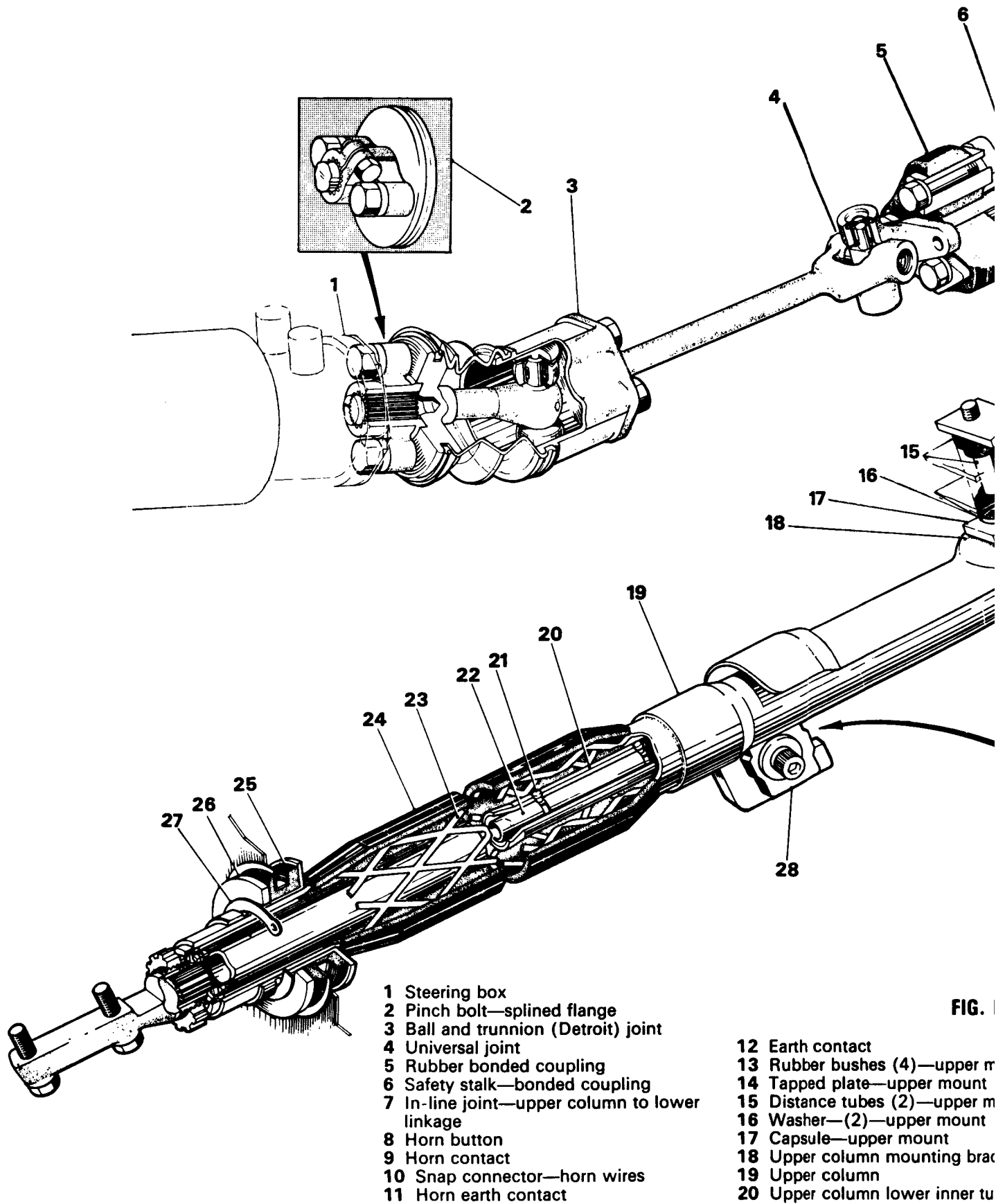
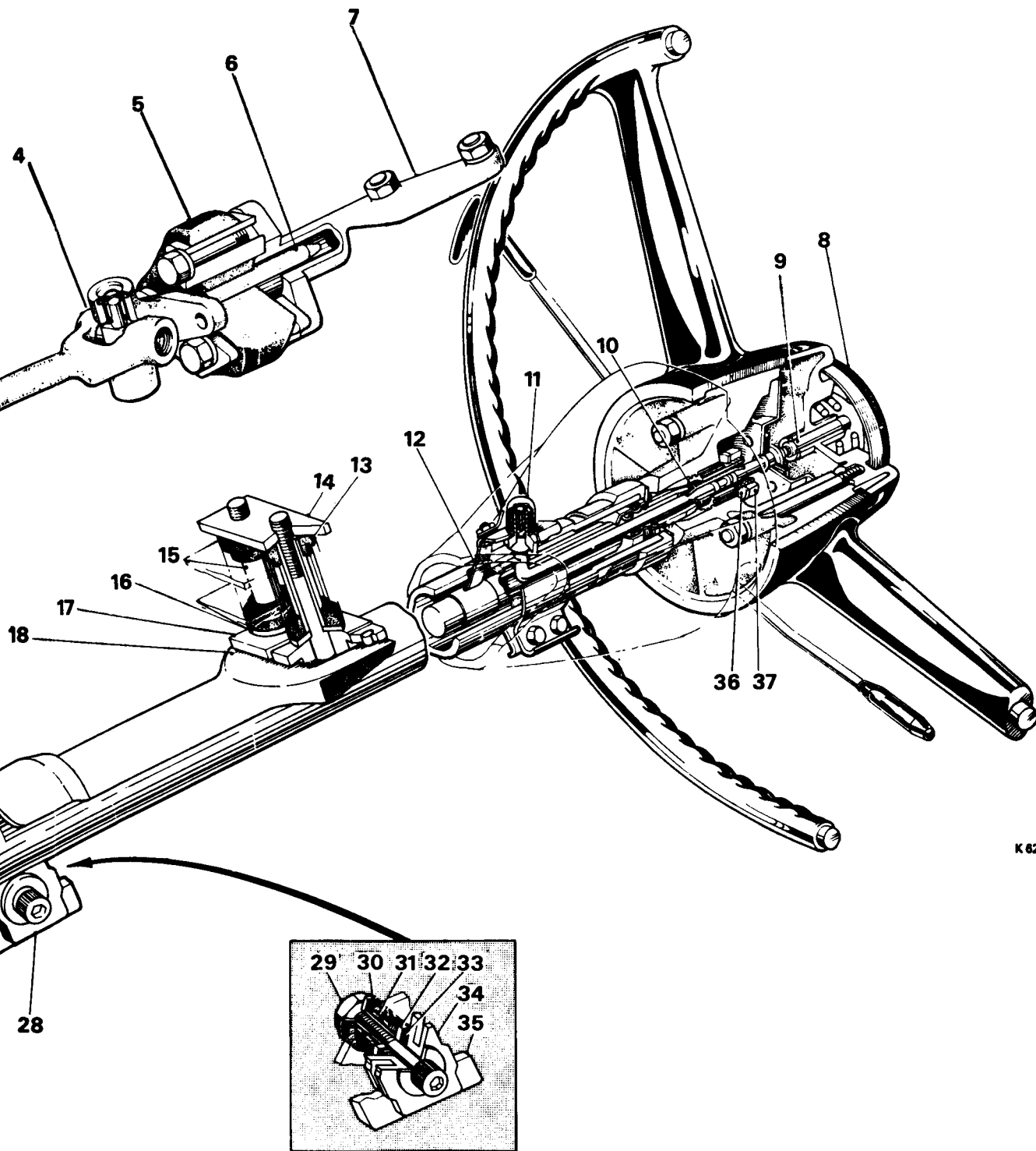

FIG. 1



K 62

FIG. N4 CUT-AWAY VIEW—ENERGY ABSORBING STEERING COLUMN AND LOWER LINKAGE

- | | | |
|--------------------------------|-----------------------------------|---------------------------------------|
| Earth contact | 21 Injected plastic rivets | 30 Plain washer |
| Rubber bushes (4)—upper mount | 22 Upper column upper inner tube | 31 Rubber bushes (2) |
| Tapped plate—upper mount | 23 Meshed section of outer column | 32 Plain washer |
| Distance tubes (2)—upper mount | 24 Plastic outer covering | 33 Shim washers (as required) |
| Washer—(2)—upper mount | 25 Toe-board grommet | 34 Capsule |
| Capsule—upper mount | 26 Washer—grommet | 35 Mounting bracket |
| Upper column mounting bracket | 27 Circlip | 36 Washer |
| Upper column | 28 Column lower mounting point | 37 Column steering wheel securing nut |
| Upper column lower inner tube | 29 Nut | |

Chapter N

Section N2

STEERING COLUMN (later L.H.D. cars) (car number SRX 6001 onwards)

Overhaul

Lower steering column—To remove (see Fig. N4)

The lower steering column linkage joints are removed from beneath the car as follows.

1. Place the car on a ramp, apply the handbrake and/or chock the road wheels.
2. Disconnect the battery leads.
3. From beneath the car, remove the two nuts, bolts and single washer retaining the halves of the in-line joint situated between the upper and lower steering columns.
4. To facilitate assembly, note that the washer removed, fits beneath the nut of the upper bolt. Lower and support the linkage then proceed to disconnect the opposite end.
5. Remove the pinch bolt of the slotted flange behind the ball and trunnion joint where it fits onto the splined input shaft of the steering box.
6. Suitably scribe or mark correlation markings on the steering box input shaft, clamping plate and ball and trunnion joint to facilitate assembly.
7. Remove the lower steering linkage from the car taking care not to extend the ball and trunnion joint too much.

Lower steering column ball and trunnion joint—To dismantle, To inspect, To assemble

Refer to page N1 of Section N1.

Lower steering column universal joint—To dismantle

If the universal joint is unserviceable through excessive wear and/or grease leakage, the joint must be dismantled and a replacement kit fitted, comprising a cruciform, seals and bearings.

Proceed as follows.

1. Using circlip pliers remove the circlips which retain the needle roller bearing races, then using a hide or wooden mallet, tap the yokes until each bearing in turn is driven out of the yoke eyes. Remove the cruciform.

Lower steering column universal joint—To assemble

1. Smear the bearing surfaces of the new cruciform with grease and fit a new seal to the inner end of each surface diameter.
2. Support the cruciform centrally in the yokes, then carefully press each new bearing assembly into its respective yoke eye. Each bearing must be pressed into the yoke such that it clears the circlip groove.
3. Fit each circlip into its respective groove ensuring that each is fully seated.
Test the joint by moving it through its maximum angular movement.

Lower steering column rubber/bonded coupling—To renew

Refer to page N2 of Section N1 except for the following notes

Chapter N

The coupling of cars fitted with the energy absorbing steering column and universal (Hardy Spicer) coupling, is fitted with four setscrews and washers. These are tightened to standard torque figures quoted in Chapter P of this Manual.

Note that the coupling is fitted with the 'fail safe' stalk toward the upper link.

Lower steering column assembly—To fit

Reverse the procedure given for its removal, ensuring that the correlation marks align. Small adjustment can be made later at the front joint flange with slotted holes to correct steering wheel spokes alignment.

Upper steering column—To remove

Note Use only the special steering wheel removal tool (RH 7870). Use of any other tool or method might damage and possibly shear the plastic rivets of a serviceable steering column rendering it unserviceable.

Some early service tools (RH 7870) had a single diameter pressure pad attached to the lower end of the centre screw.

It is essential that a **later tool** having the same number be used. This tool has an extension on the pressure pad measuring 0.500 in. diameter by 0.500 in. length (12,7 mm. by 12,7 mm.).

1. Disconnect the battery leads.
2. Lower the distribution board (fuse panel) to gain access to the screws securing the trim fairing and knee pads adjacent to the column; remove the trim fairing and knee pads. The trim and pads also incorporate spring clips.
3. Remove the steering column cowling by first removing the four outer 'Phillips' headed screws.
4. Remove the three screws securing the gearchange wiring contact plate to the selector; detach the wiring and contact plate from the selector.
5. Remove the top roll trim pad as follows.
 - (i) Remove the polished veneer facia panels secured by chromium plated screws. The upper screws of the panels also secure the upper edge of the roll.
 - (ii) Lower the cubby box lid and from behind the forward edge, remove two screws.
 - (iii) Remove the two remaining screws situated behind the lower edge of the roll at each end.
 - (iv) Remove the roll.

6. Detach the plug from the socket of the direction indicator switch loom.

7. Remove the two remaining screws securing the cowling lower half to the column; collect the washers and brackets.

8. Remove the three nuts located behind the steering wheel and remove the horn button assembly from the steering wheel centre.

(i) Withdraw the horn contact plate and detach the horn cable.

9. Unscrew and remove the nut and washer securing the wheel to the column.

10. Prior to fitting the steering wheel extraction tool, scribe suitable markings on the wheel hub and column to facilitate correct alignment on assembly if the original column is to be refitted.

11. Fit the extraction tool (RH 7870) to the wheel, the pressure plate bearing centrally on the column inner tube. It will be necessary to push the horn cable into the tube.

(i) Remove the steering wheel then remove the service tool.

12. Detach the horn earth contact from the upper column outer tube.

(i) Remove the screw securing the earth contact strip to the column and remove the strip.

13. Remove the large circlip and washer from the base of the upper column.

14. Using an Allen key, remove the screw from the lower column support; collect the nut, washers and any fitted slotted shims.

(i) Using the same Allen key, remove the two screws from the upper bracket; collect the tapped plate and plain washers. Access to the plate is from behind the instrument panel.

15. Support the detached column and remove by pulling it out of the rubber grommet in the toe-board.

No servicing is possible on the upper column and if damaged it must be discarded and a new column fitted.

Upper steering column—To fit

1. Examine the toe-board rubber grommet and renew if necessary.

2. Examine and renew if necessary, the four rubber bushes of the upper support bracket and ensure that the two distance tubes are fitted.

Chapter N

3. Examine and renew if necessary, the two rubber bushes of the lower support bracket and ensure that the distance tube is fitted.

4. Examine the large circlip and groove into which it seats at the base of the column. The circlip and groove must be clean and free of paint, the circlip should be checked in the groove to see that it will seat correctly.

5. Fit the column through the rubber grommet in the toe-board. Take extra care not to knock either end of the inner column, thus causing possible damage to the injected plastic rivets, rendering the column unserviceable.

6. Take the weight of the column by fitting the two screws of the upper mounting bracket with a washer fitted to each side of the capsule. Pass the screws through the respective capsules and distance tubes and locate and finger tighten the tapped plate.

7. Fit the large diameter thick washer to the column on the underside of the toe-board and fit the large circlip. It is important that the circlip is fully seated in its groove on the column.

8. Fit a washer to either side of the lower capsule and slide the screw, from the column side, through the assembly, i.e. distance piece, rubbers, capsule and washers, and secure with a plain washer and nut.

9. Temporarily fit the knee pads to either side of the column. Also, temporarily fit the lower half of the cowl on to the column and centralise the bottom edge of this with the knee pads. When this position has been achieved, remove the lower cowl and trim and tighten the upper mounting bracket screws.

10. Making sure that there is no pre-load on the bolt of the lower mounting bracket, measure the gap between the centre washer and the capsule using feeler gauges, and add to the measured gap 0.28 in. (0.71 mm.) for rubber compression.

Refer to the following chart for washer selection.

Note These washers are slotted to enable them to be inserted without the necessity of having to remove the cap screw.

It is permissible, if there is a shortage of slotted adjustment washers, or, if a large quantity of washers have to be fitted, that a plain washer similar to the ones fitted beneath the nut and head of the cap screw be substituted for every two adjusting washers required. The substitute washer(s) must be situated at the capsule side of the adjusting washers (*see inset*

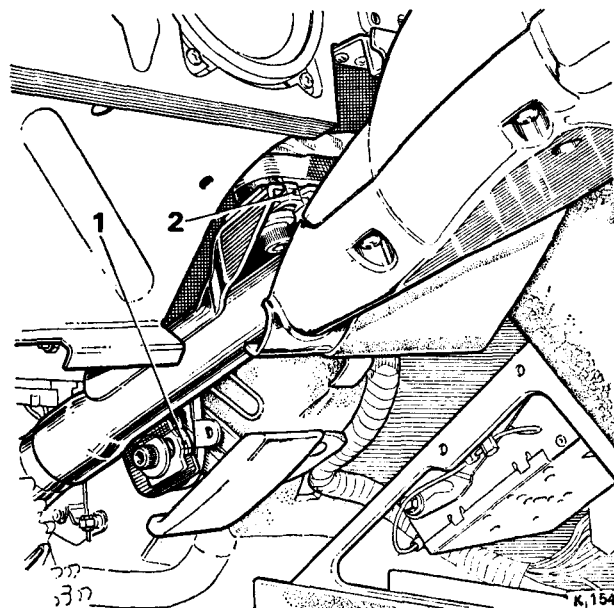

FIG. N5 MOUNTING POINTS—ENERGY ABSORBING STEERING COLUMN

1 Lower mounting point

2 Upper mounting point

Fig. N4) thus sandwiching the remaining washers between the plain washers. To insert a plain washer(s) it will be necessary to withdraw the cap screw.

Washer (shim) selection chart

| Measured Clearance | Clearance + 0.028 in. (0.71 mm.) for rubber Compression | Number of Adjusting Washers |
|---|---|-----------------------------|
| Zero-0.014 in. (Zero-0.35 mm.) | 0.028 in.-0.042 in. (0.70 mm.-1.06 mm.) | 1 |
| 0.015 in.-0.043 in. (0.38 mm.-1.09 mm.) | 0.043 in.-0.071 in. (1.09 mm.-1.80 mm.) | 2 |
| 0.044 in.-0.072 in. (1.11 mm.-1.83 mm.) | 0.072 in.-0.100 in. (1.83 mm.-2.54 mm.) | 3 |
| 0.073 in.-0.101 in. (1.85 mm.-2.57 mm.) | 0.101 in.-0.129 in. (2.57 mm.-3.27 mm.) | 4 |
| 0.102 in.-0.130 in. (2.59 mm.-3.30 mm.) | 0.130 in.-0.158 in. (3.30 mm.-3.91 mm.) | 5 |
| 0.131 in.-0.159 in. (3.33 mm.-3.94 mm.) | 0.159 in.-0.187 in. (3.94 mm.-4.75 mm.) | 6 |
| 0.160 in.-0.188 in. (4.06 mm.-4.78 mm.) | 0.188 in.-0.216 in. (4.78 mm.-5.48 mm.) | 7 |
| 0.189 in.-0.217 in. (4.80 mm.-5.51 mm.) | 0.217 in.-0.245 in. (5.51 mm.-6.22 mm.) | 8 |

Chapter N

11. Fit the required adjusting washer(s) **between the capsule and the centre washer** of the lower column support bracket and using a torque spanner fitted with an attachment suitable for tightening cap screws, torque tighten to 21 lb. ft. (2,90 kg.m.), the cap screw together with the two cap screws of the upper bracket.

12. Fit the steering wheel using the combined extraction and insertion tool (RH 7870) remembering to align the markings inscribed on the column and wheel hub prior to removal. Fit the washer and torque tighten the nut to between 25 lb. ft. (3,48 kg.m.) and 28 lb. ft. (3,87 kg.m.).

Note It is important that the service tool (RH 7870) be used to draw fully, the wheel on to the splines. On no account should a mallet, or force be used by the fitter to partially engage the wheel on to the column splines. Do not exceed the torque figure quoted for the steering wheel securing nut.

13. With the road wheels in the straight-ahead position, check that the spokes of the steering wheel are centralised. If any misalignment is evident, minor adjustment can be made at the splined flange clamped to the steering box input shaft, as follows.

Slacken the two setscrews adjacent to the steering box and rotate the steering wheel sufficiently to centralise it; re-tighten the setscrews.

14. Fit the horn button and plate, steering column lower cowl, the electrical wiring, the upper cowl, wooden fascia panels, top roll, column fairing, knee pads and trim by reversing the procedure given for their removal.

Fit the horn earth connection and earthing strip to the upper steering column outer tube.

Section N3

STEERING PUMP (Hobourn Eaton) AND HOSES

Overhaul

Steering pump—To remove

1. If the pump is to be dismantled or the pulley removed from the pump, it is advisable to slacken the pulley retaining setscrew while the pump is in position and the belts are tight.

2. Slacken the belt adjuster and remove the belts.

3. Using a syringe draw off and discard the fluid from the pump.

Note When inserting a syringe take care not to damage the filter support plate.

4. Clean the area around the pump hose connections on the steering pump.

5. Disconnect the pump hoses and blank the end to prevent fluid spillage and the ingress of dirt.

6. To completely drain the pump of fluid, place a container under the discharge pipe and rotate the steering pump by hand in the normal direction of rotation.

7. Remove the two nuts securing the pump mounting bracket to the engine and remove the pump.

Steering pump—To test

If facilities exist, it is advisable to test the pump to ensure that it is delivering the correct pressure and flow.

Test data

| | |
|------|--|
| Flow | 2.2 gal. to 2.5 gal. (10,00 litres to 11,36 litres) per minute at 3,000 (pump) r.p.m. and 50 lb/sq. in. to 60 lb/sq. in. (3,515 kg/sq. cm. to 4,218 kg/sq. cm.). |
|------|--|

Pressure Min. 1,000 lb/sq. in. (70,30 kg/sq. cm.) at 600 (pump) r.p.m. at no fluid flow.

Max. 1,050 lb/sq. in. (73,82 kg/sq. cm.) at 3,000 (pump) r.p.m. at no fluid flow.

Note The pump must not be held at full pressure for more than 5 seconds during Rig Testing.

If the steering pump is not delivering the correct pressure and flow, check that the flow control valve is not sticking. If the flow control valve is found to be operating satisfactorily, it will be necessary to dismantle and inspect the pump.

Steering pump—To dismantle and inspect

For identification of detail components refer to *Figure N7*.

1. Thoroughly clean the exterior of the pump, taking care that no foreign matter enters the inlet or outlet ports.

2. Clamp the pump mounting bracket in a vice fitted with protective grips.

3. Remove the reservoir cover. Lift off the spring and filter retaining washer and withdraw the filter.

4. Fit a $\frac{5}{8}$ in. U.N.F. nut and setscrew to the centre pedestal, tighten the nut and remove the pedestal.

5. If this method is unsuccessful, a pair of grips may be used to remove the pedestal. Leave the bolt screwed in and grip on that part of the pedestal to which the bolt is fitted, otherwise it will collapse.

6. Remove any burrs caused by the grips otherwise the filter retaining washer will not retain the filter in position.

7. Remove the filter support plate.

8. Remove the setscrew and the $\frac{3}{4}$ in. U.N.F. blanking plug, then withdraw the clamp plate.

Chapter N

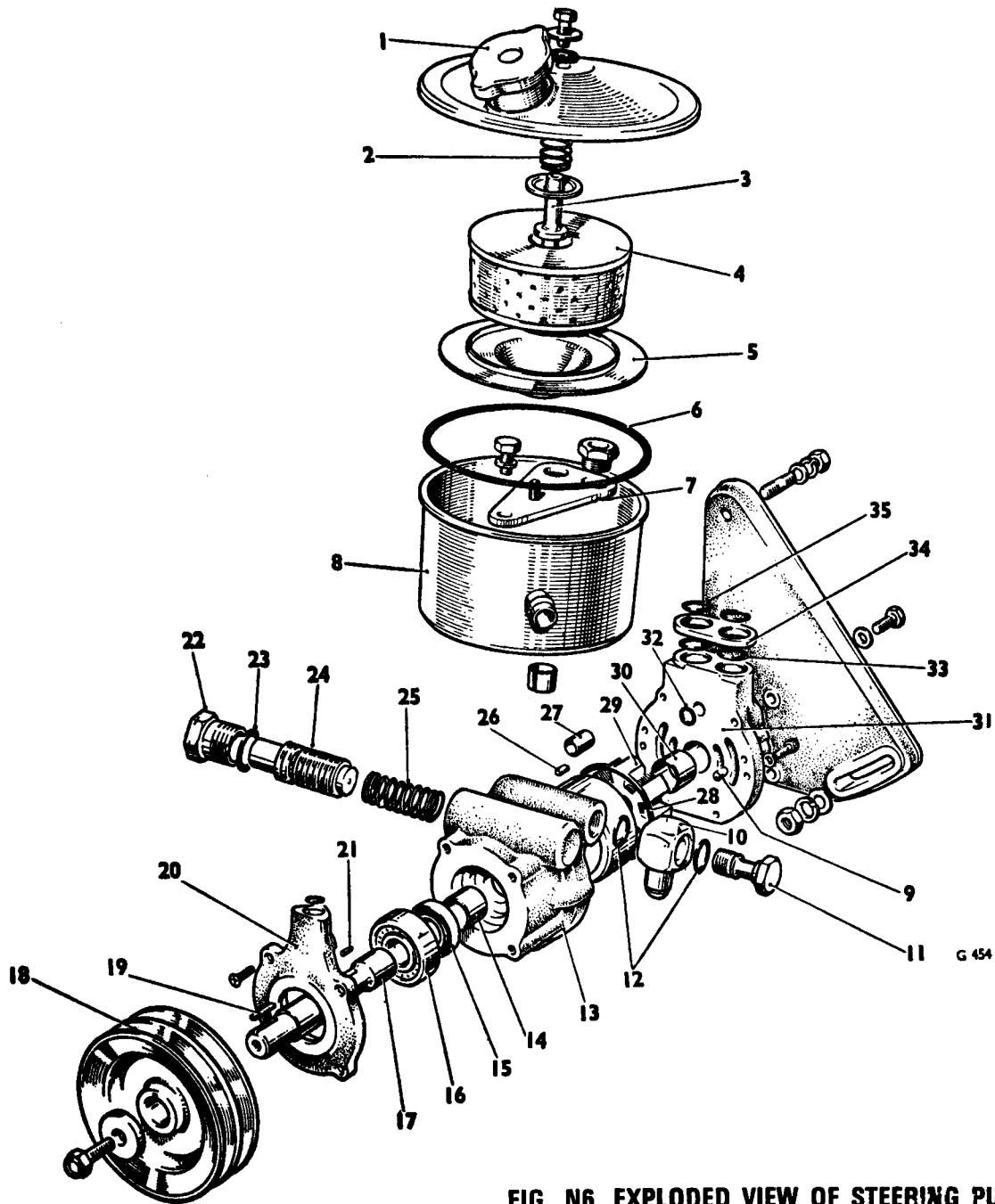

FIG. N6 EXPLODED VIEW OF STEERING PUMP

- | | | | |
|------------------------|------------------|--|-------------------|
| 1 Filler cap | 10 Banjo adaptor | 19 Key | 27 Roller |
| 2 Spring | 11 Adaptor bolt | 20 End plate | 28 Sealing ring |
| 3 Pedestal stud | 12 Sealing rings | 21 Driving pin | 29 Rotor |
| 4 Filter | 13 Pump body | 22 Plug | 30 Bush |
| 5 Filter support plate | 14 Bush | 23 Sealing ring | 31 Cover |
| 6 Sealing ring | 15 Oil seal | 24 Combined oil flow and pressure relief valve | 32 Sealing ring |
| 7 Clamping plate | 16 Bearing | 25 Valve spring | 33 Sealing ring |
| 8 Reservoir | 17 Shaft | 26 Key—cam ring | 34 Distance piece |
| 9 Dowel | 18 Pulley | | 35 Sealing ring |

9. Lift off the reservoir body taking care not to misplace the rubber sealing rings and distance plate located beneath the body.

10. Withdraw the split sleeve from the inlet port of the pump, but do not attempt to withdraw the venturi beneath it. If this is loose, the rotor and cam ring will probably be damaged and will cause noisy pump operation. The venturi is an interference fit between its largest diameter and its bore. If it is loose, swell the interference diameter by pressing a large ball-bearing into the end of the venturi. Examine the rotor, rollers and cam ring for pitting and wear and renew them if necessary. Also, if the pump makes a chattering noise, audible from outside the car, the rotor, rollers and cam ring should be renewed.

11. If necessary, remove the pump pulley; take care to retain the Woodruff key.

12. Using an Allen key unscrew the six socket-headed screws which secure the two halves of the pump body together.

13. Separate the pump from the cover and collect the sealing ring.

14. Before removing the rotor, rollers and cam ring **take note** of the direction in which the rotor is fitted.

Using a straight edge across the body of the pump, check, with a feeler gauge, the end clearance of the rotor and rollers. This should be within the range 0.001 in. to 0.0018 in. (0.025 mm. to 0.046 mm.).

15. Remove the rotor, rollers and cam ring from the pump body, taking care not to misplace the rotor driving key from the shaft.

16. Unscrew the four countersunk-headed screws and remove the bearing retaining plate.

17. Remove the shaft from the housing, then gently tap the oil seal of the housing.

18. Inspect the bearing for wear or damage; if excessively worn the bearing should be removed from the shaft and a new one fitted.

19. Remove the flow control valve plug from the side of the pump body and withdraw the combined flow control and relief valve, taking care to retain the flow control valve spring.

20. Inspect the pump body and cover for wear or scoring by the rotor; if excessive wear or scoring has taken place and the end clearance of the rotor in the body exceeds 0.0018 in. (0.046 mm.), the body and cover should be renewed and a matched set of rotor, rollers and cam ring fitted.

Steering pump—To assemble

1. Thoroughly clean all parts in paraffin and dry them using a high pressure air line.

2. After greasing the lip of the new seal, insert it into the pump body. Care should be taken not to damage the seal.

3. Insert the drive-shaft, at the same time turning it so as to minimise the risk of damage to the oil seal. Tap the bearing into the body, then fit the bearing retaining plate and the four countersunk-headed screws.

4. Fit the cam ring, ensuring that it is located correctly on the pin in the pump body.

5. Fit the key and slide the rotor on to the shaft. The rotor should be fitted so that when viewed from the rear of the pump, the angled face of the rotor blades should face anti-clockwise.

6. Insert the six rollers into the spaces between the rotor blades. Fit new rubber sealing rings in the annular groove formed on the end of the cam ring and in the recess formed in the flow control by-pass port.

7. Fit the six Allen setscrews and secure the cover to the pump body. Whilst tightening the setscrews rotate the shaft to ensure that no binding takes place.

8. Fit the flow control valve spring and the combined flow control and relief valve into the pump body, ensuring that it moves freely in its bore.

9. Fit the flow control valve cap using a new 'O' ring.

10. Fit the reservoir to the pump body ensuring that new sealing rings are fitted to each side of the distance plate. Fit the sleeve into the inlet port of the pump, then using the $\frac{3}{4}$ in. U.N.F. blanking plug and the $\frac{1}{8}$ in. U.N.F. setscrews and 'O' ring secure the reservoir firmly to the pump body.

11. Fit the filter support plate and the centre pedestal, then tighten the pedestal (see method given for removal).

12. Fit the filter, filter retaining washer, spring and reservoir cap ensuring that the reservoir cap seal and the securing screw seal are in good condition.

Steering pump—To fit

To fit the steering pump to the engine, reverse the procedure given for its removal noting the following points.

1. After fitting, check the belt tension and fill and prime the system as described later.

Chapter N

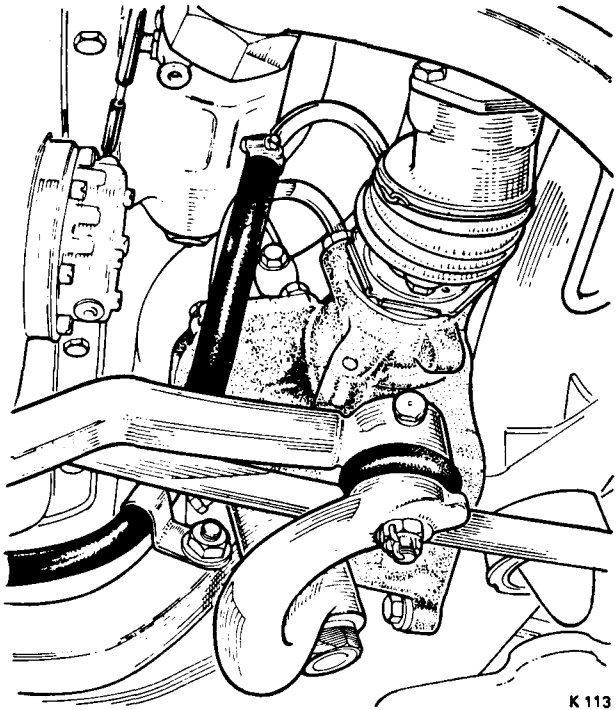

FIG. N7 STEERING BOX HOSE CONNECTIONS

Steering pump hoses

On right-hand drive cars, the supply and return hoses connecting the steering pump to the steering box, drop vertically from the pump to a clip on the upper triangle lever mounting bracket; from there they pass across the front engine cross-member, being clipped to it at two points. A shield is fitted to protect the hoses from heat given off by the exhaust pipe. From the front engine cross-member the hoses pass to the steering box (see Fig. N7).

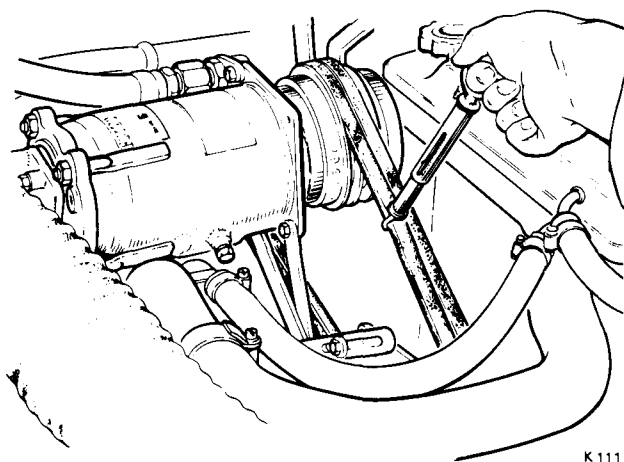

FIG. N8 STEERING PUMP—BELT TENSION CHECK

On left-hand drive cars the supply and return hoses connecting the steering pump to the steering box, drop vertically from the steering pump to the steering box. They are secured to each other by a plastic clip mid-way along their length.

With the engine running and the road wheels on the ground, turn the steering from lock-to-lock and check that the hoses do not distort.

Maintenance

Steering pump fluid level—To check

1. Start the engine and run it at idle-speed and if necessary top-up with the approved fluid (see Chapter D), until the fluid level is just above the lowest point of the top face of the filter.

2. Road test the car.

3. Re-check fluid level.

Note It is of the utmost importance that only clean fluid be used to top-up the steering pump reservoir.

Filter element—To renew

1. Using a syringe, draw off and discard as much fluid as possible from the pump.

2. Unscrew the setscrew securing the cover then remove the cover and spring; discard the filter element. Fit the new element in the pump reservoir.

3. Examine the seal in the cover; renew if necessary. Care should be taken to ensure that the oil sealing ring is seating correctly.

4. Fit the cover squarely on to the pump and tighten the setscrew.

Belt tension—To check

The steering and refrigeration pumps are driven by a matched pair of belts from the two front grooves of the engine pulley.

1. Check the tension of the belts by applying a force of 8 lb. (3,63 kg.) at the centre of the run between the coolant pump and steering pump. Each belt should show a deflection of 0.375 in. (9,53 mm.).

2. If the tension of the two belts differs markedly, a new matched pair of belts should be fitted.

3. To adjust the belts slacken the pump securing nuts and move the pump until the correct belt tension is obtained; tighten the nuts.

A slipping belt will emit a 'squeal' and produces also 'judder' at the steering wheel, especially when approaching each full lock.

No dressing of any kind should be applied to the belts to prevent slip.

Priming and filling the system

1. Fill the steering pump reservoir with clean fluid until the fluid level is just above the top of the filter.
2. Start the engine and run it at 'idle' speed.
3. Move the steering wheel from lock-to-lock in order to expel the air from the system. The level of the fluid in the steering pump reservoir must be checked continually and kept topped-up to the correct level.

A considerable amount of noise may be apparent during the initial priming of the system.

Movement of the steering wheel should be repeated until all the air is expelled. All joints should be inspected for leaks and rectified if necessary.

4. Finally, return the steering wheel to the central position and check the level of the fluid in the steering pump reservoir.

Note Care should be taken to avoid spilling fluid on the pump driving belts.

5. On completion of the priming and filling operation, the pump belts should again be checked for correct tension, the car road tested and the fluid level rechecked.

Section N4

STEERING PUMP (SAGINAW), FLUID COOLER AND HOSES

Overhaul

Introduction

This pump was first introduced on cars with full refrigeration equipment, from the following numbers.

Standard Cars —SRX 2982, SRH 2297, SBX 3002,
SRX 3003, SRX 3005 and on-
wards

Coachbuilt Cars—CRH 3132 and onwards

Steering pump—To remove

1. If the pump is to be removed for dismantling purposes, it will first be necessary to remove the pulley. In order to slacken the pulley retaining nut, use the tension of the pump driving belts to prevent the pulley from rotating while a spanner is used to slacken the nut.

2. Using a syringe, draw off as much fluid as possible from the steering pump reservoir into a container.

3. Slacken the pump belts by loosening the locking screw in the slotted adjustment bracket, the nut on the pivot bracket at the rear of the pump and the pressure hose connection at the rear of the pump. Remove the belts.

4. Disconnect the two hoses, one at a time. Mask or cap the pump orifices for the hoses to prevent further drainage of fluid and secure the ends of the hoses in a raised position to prevent fluid drainage from them. Mask or blank the ends of the hoses to prevent the ingress of dirt.

5. Remove the nut, bolt, spring washer and chamfered washer from the top hole of the mounting brackets.

6. From the rear side of the pump, remove the two retaining nuts (the lower one with distance piece).

7. Support the pump and remove the locking setscrew of the slotted adjustment bracket. Remove the pump and collect the slotted distance piece located on a dowel fitted to the pump front lower bracket which remains on the engine.

Steering pump—To dismantle

1. Drain any fluid remaining in the pump.

2. Remove the nut and washer from the drive-shaft. Remove the pulley from the keyed shaft. If necessary use a suitable pulley extractor to remove the pulley. Never use a hammer to drive the pulley from the shaft as this will cause damage to the pulley and pump.

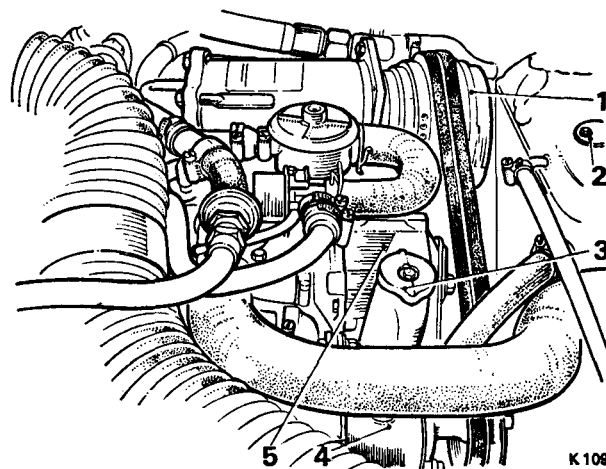
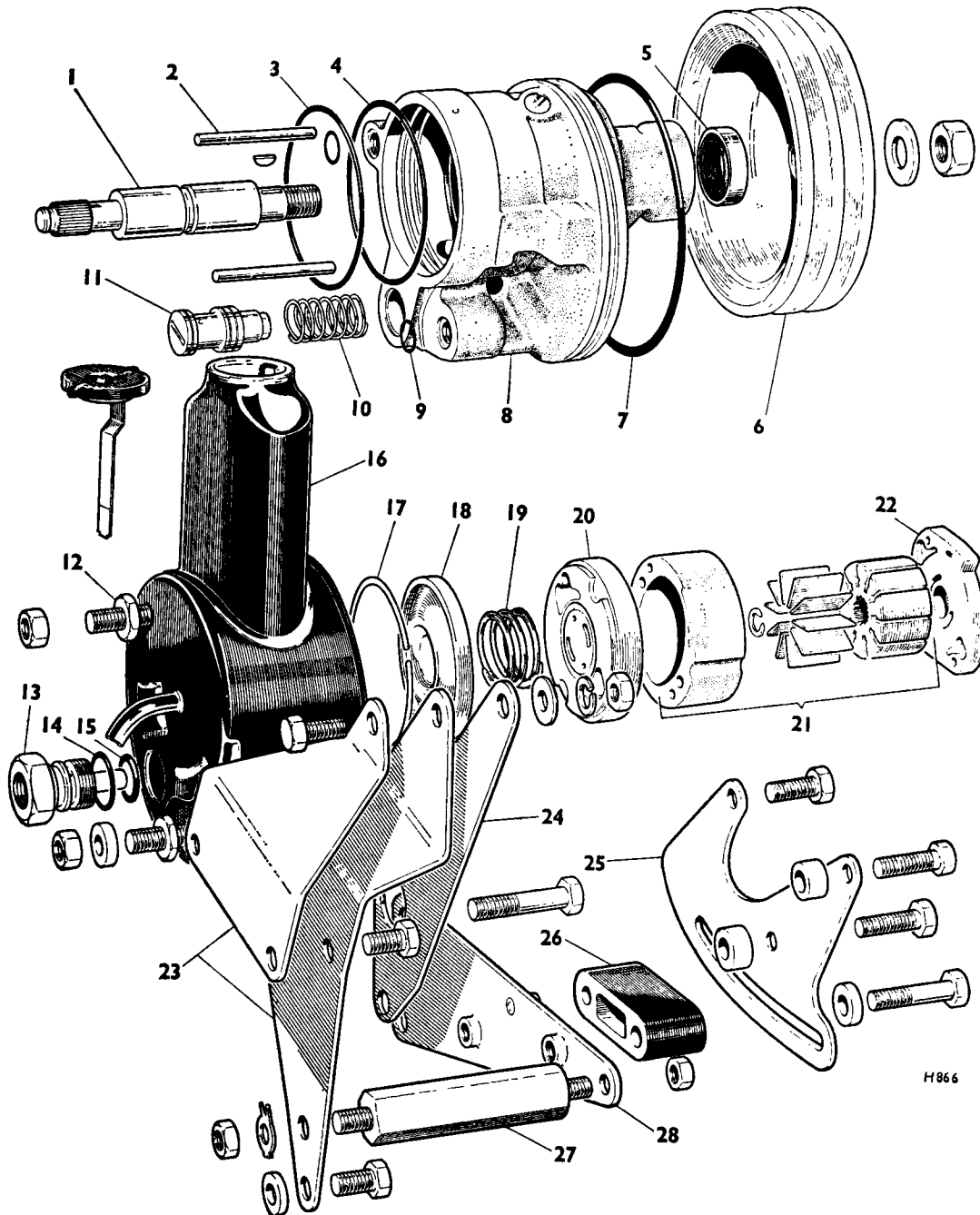

FIG. N9 STEERING PUMP IN POSITION

- 1 Refrigeration pump
- 2 Pressure valve—header tank
- 3 Steering pump filler cap
- 4 Steering pump
- 5 Air injection pump (if fitted)

Chapter N



H866

FIG. N10 EXPLODED VIEW—STEERING PUMP (SAGINAW) AND MOUNTING BRACKETS

- | | | |
|--|--|---|
| <p>1 Drive-shaft 2 Dowel pins 3 Sealing ring—end plate 4 Sealing ring—pressure plate 5 Shaft lip-type seal 6 Pulley 7 Sealing ring—reservoir 8 Pump housing 9 Sealing ring—reservoir to pump housing securing studs 10 Return spring—flow control valve</p> | <p>11 Combined flow control/pressure relief valve 12 Securing studs—reservoir to pump housing 13 Pressure union fitting—pump to steering box 14 Pressure fitting 15 Sealing rings 16 Combined reservoir/cover 17 End plate retaining ring 18 End plate 19 Pressure plate spring 20 Pressure plate</p> | <p>21 Pump ring, snap ring, vanes and rotor (supplied in kit form as spares) 22 Thrust plate 23 Pump rear mounting brackets 24 Pump rear pivot bracket—belt tensioning 25 Pump front pivot bracket—belt tensioning 26 Pivot bracket distance piece 27 Extension piece 28 Pump front lower mounting bracket</p> |
|--|--|---|

3. Remove the three setscrews securing the bracket to the front of the pump. Two of the setscrews are fitted with distance pieces, note the positions to facilitate assembly.

4. Using suitable soft vice grips, lightly clamp the pump drive-shaft downward in a vice.

5. Remove the union from the pump cover/reservoir.

Care must be taken not to exert too much pressure on the shaft when removing fittings as this may distort the shaft bearing.

6. Remove the pump rear mounting bracket and bolts.

7. Remove the cover/reservoir from the pump housing by rocking it back and forth until it clears the sealing 'O' ring.

8. Remove the sealing 'O' rings from the mounting bolts and the union (*see Fig. N11*).

9. Remove the end plate retaining ring of the pump housing. This is achieved by depressing the retaining ring using a punch inserted through the $\frac{1}{8}$ in. (3.18 mm.) hole in the pump housing (*see Fig. N12*).

10. When the ring is depressed, remove the ring from the housing with a screwdriver as shown in *Figure N12*. Withdraw the punch.

11. Remove the end plate. The plate is spring-loaded from beneath and will normally seat above the pump housing level after removal of the retaining ring. If sticking occurs, a slight rocking action will free the plate.

12. Remove the pump from the vice and invert it. The flow control valve and valve spring can be collected as they emerge from the bore (*see Fig. N13*).

13. Remove the end plate 'O' ring.

14. Invert the pump housing to leave the shaft uppermost then, using a soft-headed mallet, tap on the end of the shaft until the pressure plate falls free into the hand.

Important DO NOT drive the shaft downward into the housing more than is necessary to free the pressure plate.

15. Remove the pressure plate, pump ring and vanes, taking care not to drop the smaller components.

16. Reposition the pump housing in the vice with the open end uppermost.

17. Remove the snap ring (*see Fig. N14*) from the inner end of the drive-shaft then remove the rotor and thrust plate.

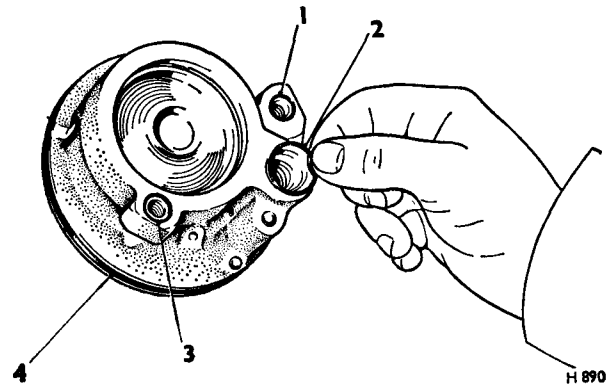

FIG. N11 POSITION OF PUMP EXTERNAL SEALING RINGS

- 1 'O' ring—cover/reservoir securing studs
- 2 'O' ring—adaptor—pressure fluid
- 3 'O' ring—cover/reservoir securing studs
- 4 'O' ring—cover/reservoir to pump housing

18. Remove the drive-shaft by passing it through the front of the housing.

19. Remove the lip-type seal from the front of the housing only if, on inspection, it is found that it requires renewal.

The dowel pins remain in the pump housing.

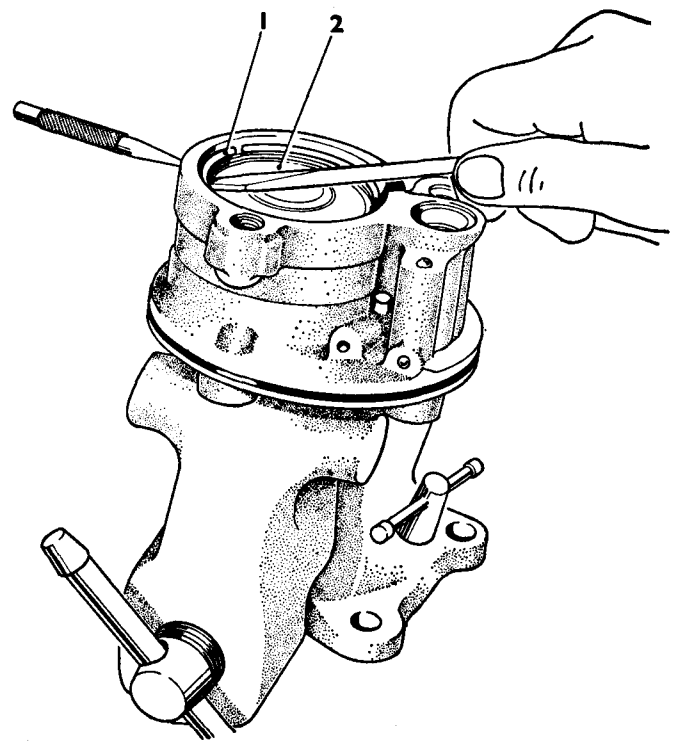

FIG. N12 METHOD OF REMOVING END PLATE RETAINING RING

- 1 Retaining ring
- 2 End plate

Chapter N

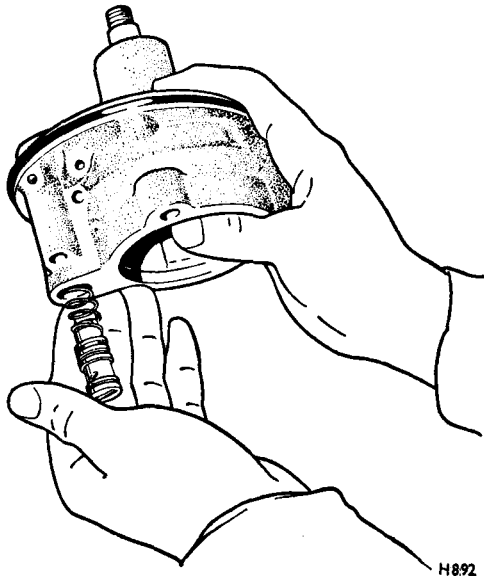

FIG. N13 REMOVING OR FITTING THE FLOW CONTROL/RELIEF VALVE

Steering pump—To inspect

1. Clean all components prior to inspection. Apply an air pressure line to the pump housing to clean out all the fluid passages.
2. Check the pressure plate, thrust plate and rotor for scoring. Light scoring may be removed by lapping with a fine carborundum stone. Heavy scoring necessitates renewal of the component concerned.

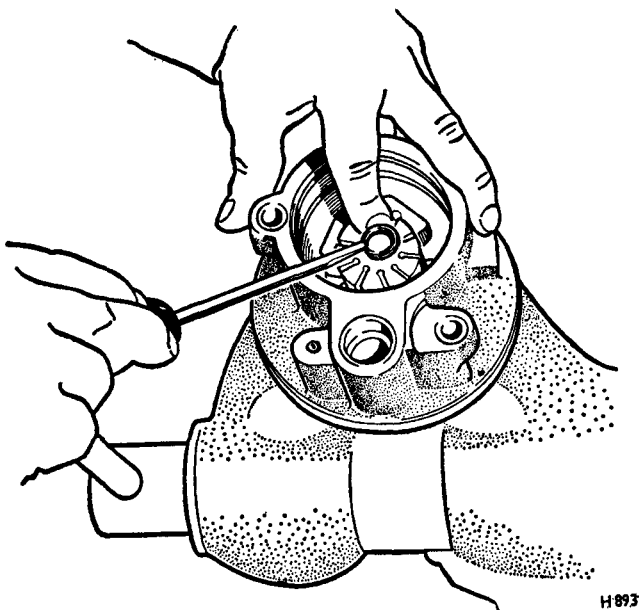

FIG. N14 REMOVING THE ROTOR SNAP RING

3. Ensure that the pressure plate is flat by checking it against the abutting surface of the pump ring.

Note A high polish is always present on the inner faces of the thrust and pressure plates as a result of normal wear. This must not be confused with scoring.

4. Check the contour surface of the pump ring for extreme wear. Normally there may be some scuff marks and uniform wear. This does not increase pump noise and is not detrimental to its function. However, if the wear comprises chatter marks or gouges that can be felt with the finger, renew the pump ring, rotor and rotor vanes (these items are supplied as a set).

5. Check the condition of the shaft bearing (bushing).

Note The bearing is rarely, if ever, responsible for noisy pump operation.

6. Check the flow control valve for burrs or dirt which may cause the valve to stick in its bore. Check the bore.

7. Check the small screw on the end of the control valve for tightness. If loose, tighten, but be extremely careful not to damage the machined surfaces.

Steering pump—To assemble

1. Before assembly, carefully clean all components with the exception of the 'O' rings which should be renewed.

Do not immerse the drive-shaft lip-type seal in a cleaning solvent as this could damage it.

2. Smear the new 'O' rings and shaft seal with petroleum jelly to facilitate correct location and fitting. Lubricate the internal metal components to be assembled with steering fluid.

3. Insert the drive-shaft into the front of the pump housing, the splined end leading and passing through the lip-type seal.

4. Fit the thrust plate over the dowel pins and into position in the housing with the ported face uppermost, i.e. to the rear of the pump housing (see Fig. N15).

5. Fit the rotor to the splines on the shaft with the counterbore toward the shaft and thrust plate. The rotor must be a slide fit on the splines.

6. Position the pump ring on the dowel pins with the direction of rotation arrow (see Fig. N16) uppermost indicating the pump direction of rotation.

The direction of rotation is anti-clockwise when viewed from the pump rear as shown in Figure N16.

7. Fit the drive-shaft snap ring to retain the rotor.

8. Fit the vanes into the rotor slots with the radiused edge facing outwards (see Fig. N17).

9. Fit the pressure plate 'O' ring. Lubricate the outside diameter of the pressure plate with petroleum jelly to prevent damage to the fitted 'O' ring, then locate it on the dowels, with the port face towards the pump ring.

10. Apply pressure to the plate at its outer edges (see Fig. N18). Never apply great pressure or hammer the centre of the pressure plate as this will cause permanent distortion resulting in pump failure. The pressure plate will compress the seal by approximately $\frac{1}{8}$ in. (1.59 mm.).

11. Position the pressure plate spring, locating the leading coil in the groove on the upper side of the plate.

12. Fit the end plate 'O' ring into the pump housing groove.

13. Lubricate the outer diameter of the end plate to prevent damage to the fitted 'O' ring. Position the pump under a suitable arbor press (see Fig. N19) and press the end plate into the housing sufficiently to allow the retaining ring to be fitted (see Fig. N12).

14. Fit the retaining ring ensuring that it is fully seated, then remove the pump from the press and tap the end plate to ensure correct seating.

15. Fit the flow control valve and spring as shown in Fig. N13.

16. Fit the smaller 'O' ring seals to the stud and flow control valve holes.

17. Fit the large 'O' ring seal to the groove on the outer diameter of the pump housing then fit the cover/reservoir.

18. Fit and tighten the two studs and union.

Note The cover/reservoir must be fully seated prior to tightening the studs and union to prevent damage to the reservoir.

19. Fit the pump front mounting (adjusting) bracket using the three setscrews. Two of the three setscrews are fitted with distance pieces.

20. If the existing shaft key requires renewal, support the drive-shaft by lightly clamping it in a vice then replace the old key.

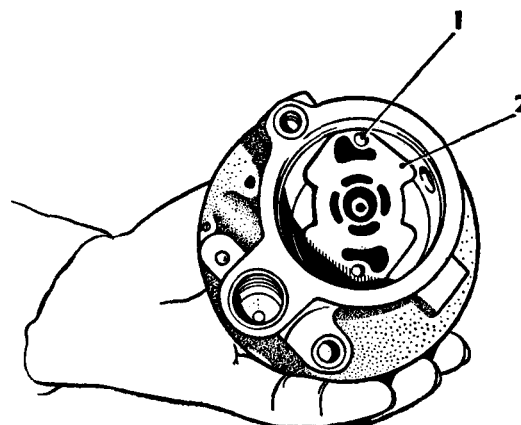

H894

FIG. N15 CORRECT POSITIONING OF THRUST PLATE

1 Dowel pin (2) 2 Thrust plate

21. Fit the pulley on to the shaft, locating the slot on the shaft key then fit the washer and nut. Partially tighten the nut. The nut can be fully tightened only when the pump is fitted to the engine complete with tightened drive belts.

Steering pump—To fit

1. Before attempting to fit the pump to the engine, check that all the steering system hoses and pipes are serviceable; renew any that are damaged or appear to have deteriorated.

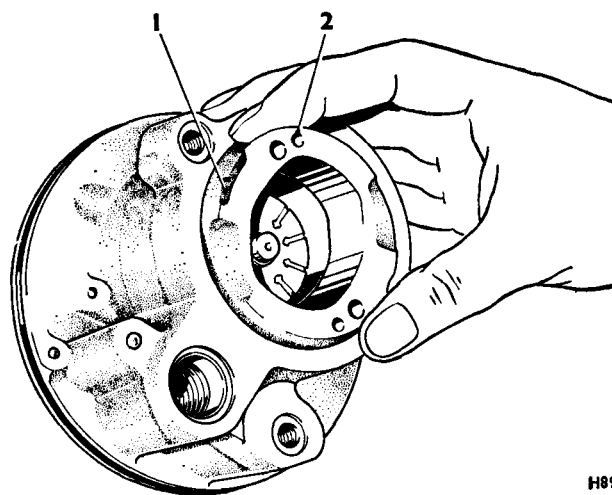

H895

FIG. N16 CORRECT POSITIONING OF PUMP RING

1 Arrow on edge of pump ring
2 Dowel hole (2)

Chapter N

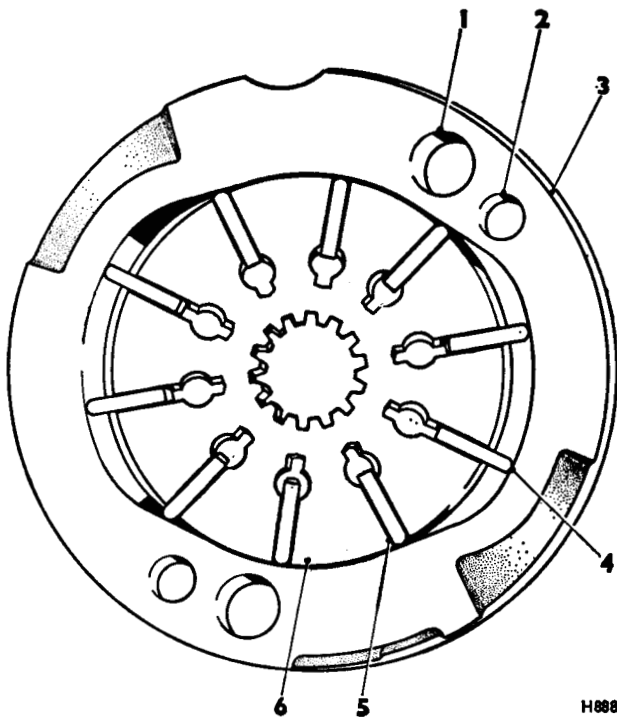

FIG. N17 PLAN VIEW—ROTOR, VANES AND PUMP RING

- | | |
|-------------------------|-------------------------|
| 1 Oil transfer hole (2) | 4 Radiused edge of vane |
| 2 Dowel hole (2) | 5 Vane (10) |
| 3 Pump ring | 6 Rotor |

Reverse the procedure adopted for the removal of the steering pump, noting the following points.

2. Prior to fitting the pump to the mounting brackets, connect but do not tighten the pressure hose to the rear of the pump.
3. Ensure that the bolt distance pieces are fitted to their respective positions.

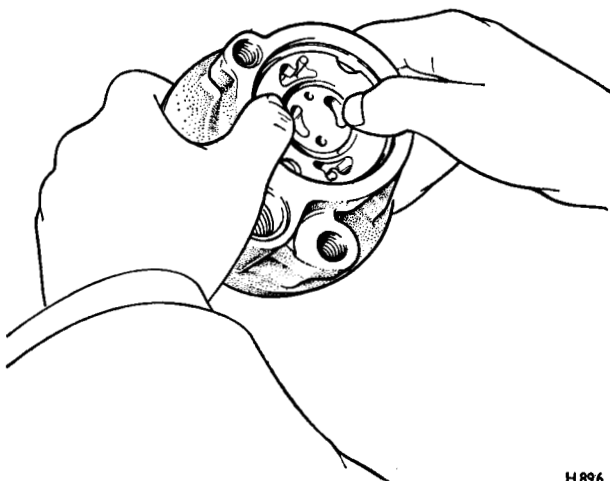

FIG. N18 FITTING THE PRESSURE PLATE

4. Tighten the pump driving belts then proceed to tighten the pulley retaining nut.

5. Adjust the driving belts to the correct tension as described in 'Belt tension—To check'.

6. Fit and tighten the hoses to the rear of the pump, then proceed to prime and fill the steering system as described in 'Priming and filling the steering system'. For reference purposes the hoses connection torque tightening figures are:

Steering pump pressure connection 25 lb. ft. to 40 lb. ft. (3,46 kg.m. to 5,53 kg.m.).

Steering box (both connections) 20 lb. ft. to 30 lb. ft. (2,77 kg.m. to 4,15 kg.m.).

Maintenance

Belt tension—To check (see Fig. N20)

A matched pair of belts drive the steering and refrigeration pumps from the two front grooves of the engine pulley.

1. The tension of these belts when correct is 70 lb. (31,75 kg.). This is checked by applying a spring balance load of 8 lb. (3,6 kg.) to cause a $\frac{3}{8}$ in. (9,5 mm.) deflection of the belts when applied to a point midway between the steering and refrigeration pumps.

If the tension in one belt differs markedly from the other, a new matched set must be fitted.

2. To adjust the tension, slacken the setscrew of the slotted swivel bracket at the front of the pump, the nut and bolt of the bracket to the rear and above the pump and slacken the union of the supply hose connected at the rear of the pump; move the pump the required amount. Tighten the setscrew, nut and bolt and the supply hose union.

Note A slipping belt(s) will emit a 'squeal' and produce 'judder' at the steering wheel, especially when approaching each full lock.

Dressing of any type must not be applied to the belts to prevent belt slip.

Steering pump fluid level—Routine check and correction

1. Remove the filler cap and check that the fluid level is at least up to the 'ADD' mark on the dipstick. If necessary add steering fluid. Use only the approved steering fluids quoted on the chart in Chapter D of this Manual.

2. Start the engine and run until normal operating temperature is reached (170°F., 77°C.) then stop the engine.

3. Remove the filler cap and check the fluid level on the dipstick. Add fluid to raise the level to the 'FULL' mark if necessary. Do not overfill. Fit the filler cap.

Priming and filling the steering system

Introduction

The Saginaw pump has a tendency to froth the steering fluid when air is present in the system. The following procedure is intended to reduce this frothing to a minimum.

If frothing of the fluid does occur, the pump will cavitate and emit a harsh buzz. This is quite usual and should cease when all the air is expelled from the system. When cavitation is audible, the pump must not be run at high speed otherwise the pump internal components may be damaged.

During the filling operation, the pump should not be required to deliver full pressure for more than 5 seconds or damage to the pump may result.

Use only the approved 'steering fluids'; these are to be found on the Lubrication Chart of Chapter D of this Workshop Manual.

Procedure

1. Turn the steering wheel to the full right-hand lock position on right-hand drive cars or full left-hand lock position on left-hand drive cars.

2. Remove the pump filler cap. Add sufficient clean steering fluid to raise the fluid level in the pump reservoir to the 'ADD' mark on the dipstick.

3. Start the engine and allow it to run at normal fast-idle. Add more steering fluid to the reservoir to maintain the level at the 'ADD' mark on the dipstick.

Do not allow the level of fluid to fall below the internal pump housing otherwise air will be pumped into the system and the procedure will become excessively prolonged.

4. Bleed air from the system by turning the steering wheel slowly from side to side, but **do not abut the full lock stops**, as the increased pressure will cause severe frothing of the aerated fluid.

5. Maintain the fluid level at the 'ADD' mark.

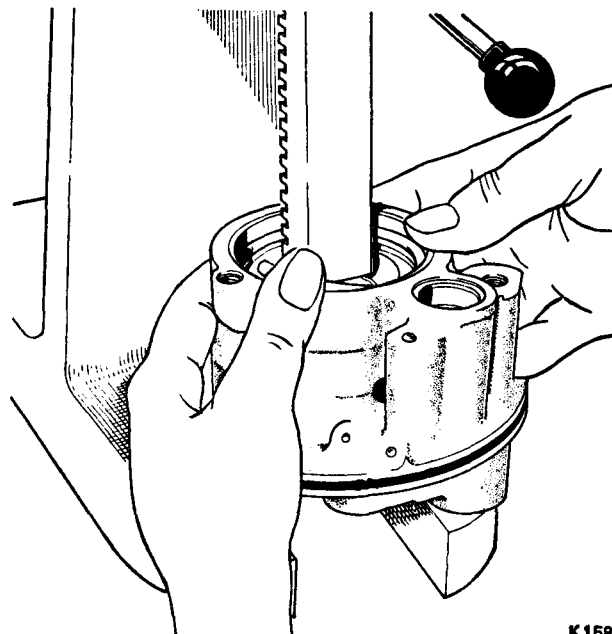

K158

FIG. N19 METHOD OF FITTING THE END CAP AND RETAINING RING

While air remains in the system, the fluid will have a light tan coloured appearance and correct steering action will not be obtained.

6. When satisfied that the fluid is no longer aerated, return the steering to the centre position and run the engine for two or three minutes, then stop the engine.

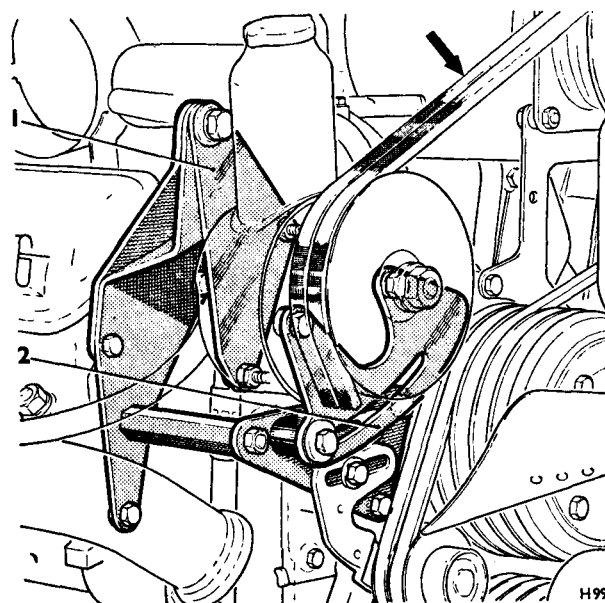

H999

FIG. N20 PUMP MOUNTING POINTS AND BELT TENSIONING ARRANGEMENT

- 1 Pump rear mounting/pivot bracket
- 2 Pump front mounting/pivot bracket
- Arrow indicates belt tension checking point

Chapter N

7. The fluid level indicated on the filler cap dipstick should be raised to the 'FULL' mark by the addition of more fluid. Do not overfill. Fit the filler cap.

Note (1) If the fluid level in the reservoir rises more than $\frac{1}{4}$ in. (6,35 mm.) when the engine is switched 'off', some residual air is present in the system and the bleeding operation should be repeated.

(2) Considerable heat is generated in the steering system during the bleeding operation therefore it should not be prolonged for more than 5 minutes.

**Steering system hoses and pipes
Right-hand drive cars (see Fig. N21)**

The flexible supply hose, connected to the high pressure outlet at the rear of the steering pump, drops vertically down the side of the engine then, sweeps rearward along the side of the engine to a clip on the rear mounting point of the front suspension upper triangle levers. The hose then curves through 180° and sweeps forward to connect to the inlet (front) connection of the steering box.

The return line from the steering box to the fluid cooler and then to the steering pump comprises lengths of flexible and rigid pipes connected by worm-drive clips. The rigid pipes are suitably shaped to follow the intended run.

The return pipe connected to the outlet (rearward) connection of the steering box sweeps forward to a mounting clip at the front end of the steering box; the pipe is rubber sleeved at this point to prevent metal-to-metal contact. After sweeping upward a short distance, the rigid pipe ends and connects to a flexible hose which continues the sweep upward to join a second rigid pipe by the wheel arch.

The second rigid pipe turns through 180° and sweeps forward to follow the contour of the wheel arch then downward toward the radiator matrix. The pipe then curves to continue vertically to meet the body cross-member which crosses between the two front wings then, turns through 90° to lie along the cross-member to join the cooler inlet (lower) connection.

A short length of flexible hose is used between the rigid pipe and fluid cooler to connect the two.

The second rigid pipe is clipped at two points, the first on the wheel arch, the second on the outer end of the cross-member.

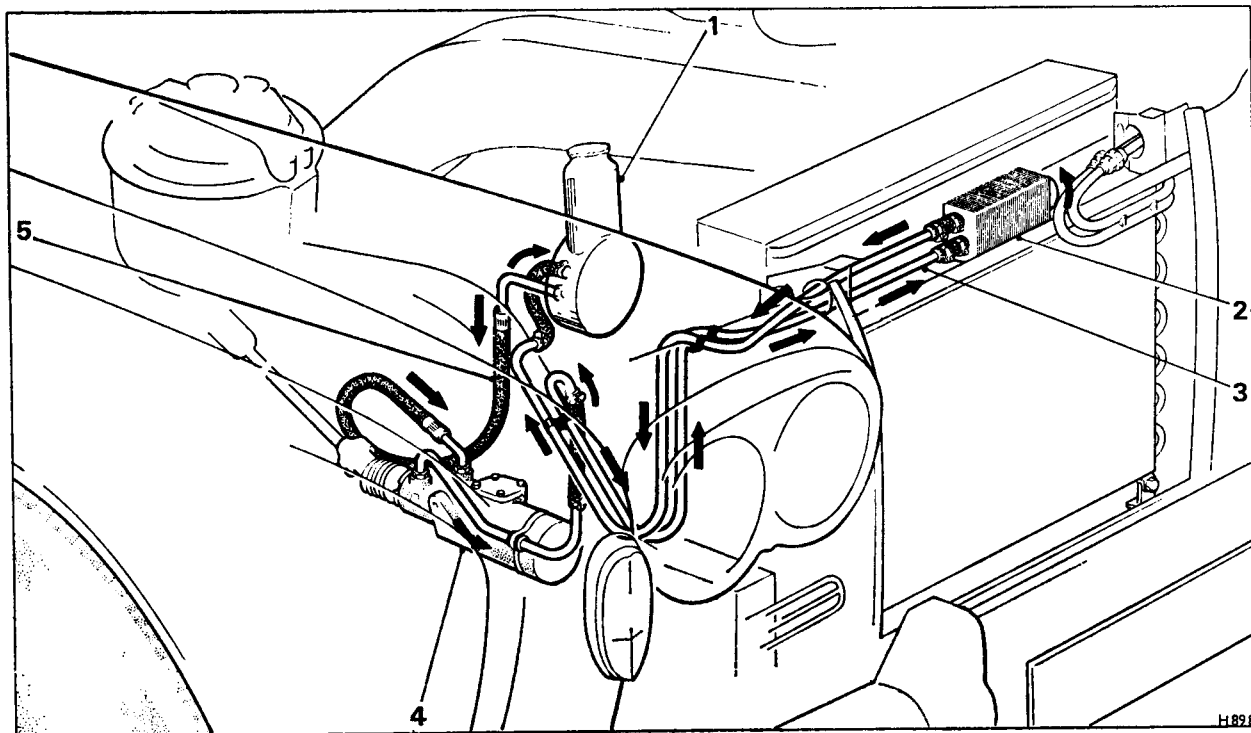

FIG. N21 STEERING SYSTEM PIPES AND HOSES—RIGHT-HAND DRIVE CARS

- 1 Steering pump 2 Fluid cooler 3 Fluid return line 4 Steering box 5 Pressure hose

Arrows indicate direction of flow of fluid

Chapter IV

The return line from the fluid cooler (upper connection) to the steering pump, follows the same run as the former and shares the same clipping points on the cross-member and wheel arch respectively. The rigid pipe joins a flexible hose which in turn sweeps downward and inward to the engine then, sweeps upward to the inlet connection at the rear of the pump.

Left-hand drive cars (see Fig. N22)

The flexible supply hose, connected to the high pressure outlet connection at the rear of the steering pump drops vertically down the engine, sweeps beneath the engine behind the engine front mounting cross-member, then sweeps upwards on the left-hand side of the engine to connect to the inlet (front) connection of the steering box. Three clips secure the hose to the engine cross-member, one at the centre and one at each end. A heat shield is secured to the member at its centre between the hose and exhaust pipe to prevent heat transference which would cause damage to the rubber hose.

The return line from the steering box, which comprises lengths of rigid pipes and flexible hoses, commences as a rigid pipe which sweeps forward along

the steering box from the outlet (rear) connection, to a clip situated at the front of the box. The pipe, rubber sleeved at this point in order to prevent metal-to-metal contact, continues its run and sweeps upward to join a flexible hose which is clipped at one end to the wheel arch. The other end of the hose joins a second rigid pipe in the upper left-hand corner of the engine compartment. This pipe curves to lie along the body cross-member between the front wings to eventually join up with the inlet (lower) connection of the fluid cooler. The pipe is clipped adjacent to, and shares a clip mounting point with the refrigeration system pipes at the front left-hand side of the engine compartment and, after turning through 180° at the end of its run, utilises a short length of flexible hose to adjoin the cooler.

From the fluid cooler (upper) outlet connection, the return line continues as a short length of flexible hose then, as a rigid pipe which travels along the body cross-member to the right-hand front wing. The pipe is clipped at this point, and then turns through 90° and sweeps vertically downward to the wheel arch then curves to follow the contour of the wheel arch to a point in-line with the steering pump. At this point the pipe turns inward toward the engine, connects to a

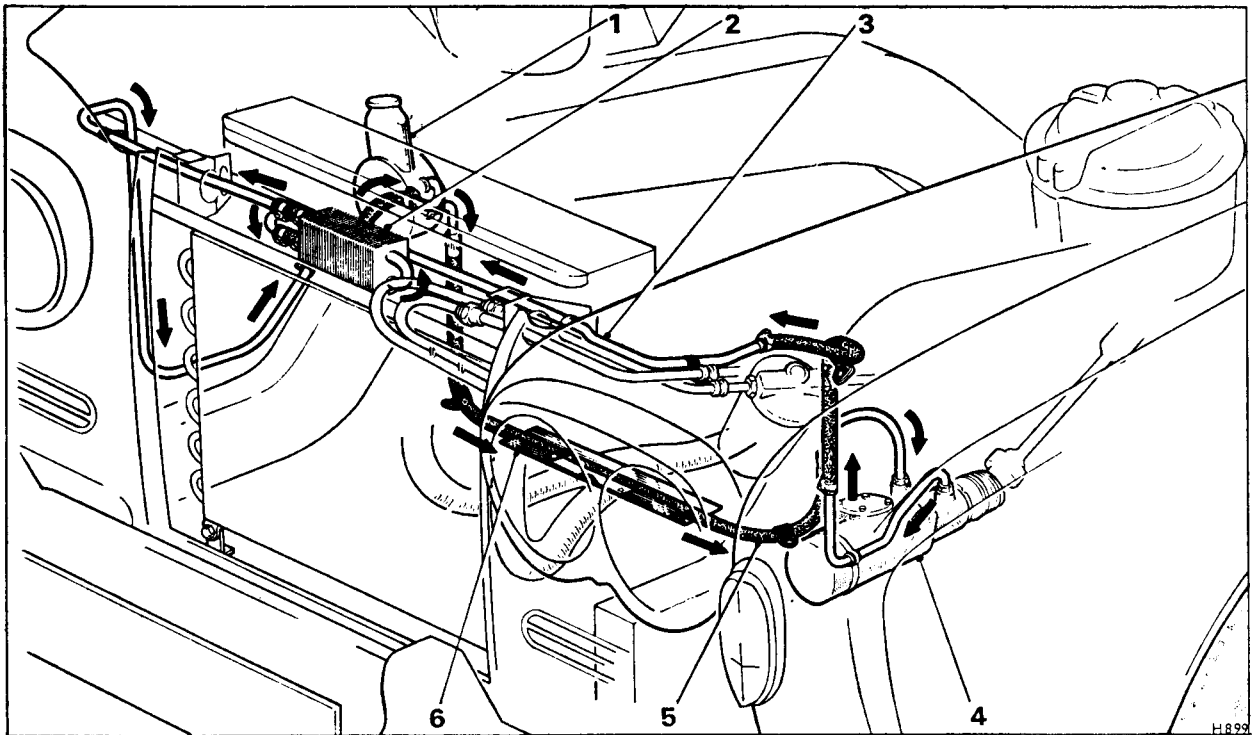

FIG. N22 STEERING SYSTEM PIPES AND HOSES—LEFT-HAND DRIVE CARS

- | | | | | |
|-----------------|----------------|---------------------|----------------|-----------------|
| 1 Steering pump | 2 Fluid cooler | 3 Fluid return line | 4 Steering box | 5 Pressure hose |
| | 6 Heat shield | | | |

Arrows indicate direction of flow of fluid

Chapter N

flexible hose which sweeps downward and finally curves upwards to join the pump inlet connection. The rigid pipe is clipped to the wheel arch.

All cars

Note The correct run of hoses must be maintained in order to prevent kinking of the flexible hoses thus restricting the flow of steering fluid.

The worm-drive clips and pipe connections must be correctly tightened to prevent fluid leakage.

Metal-to-metal contact between rigid and flexible pipes and the car body and components must be avoided, except at the clipping points, to prevent chafing, rubbing and noise transference.

Steering Pump Test Data

Minimum output 1.46 Imp. gallons per minute (1.75 U.S. gallons per minute, 6.64 litres per minute) of fluid at 170°F. (76.7°C.) when operating at 465 pump r.p.m. against 665 lb/sq. in. to 735 lb/sq. in. (46.75 kg/sq. cm. to 51.68 kg/sq. cm.) pressure.

Maximum output 2.33 Imp. gallons per minute (2.80 U.S. gallons per minute, 10.68 litres per minute) of fluid at 170°F. (76.7°C.) when operating at 1500 r.p.m. against 50 lb/sq. in. (3.52 kg./sq. cm.) pressure.

| | | |
|---------------------------------|---|--|
| Maximum sustained speed of pump | } | 5,800 r.p.m. (maximum peak speed to be 7,500 r.p.m.). |
| Pressure relief valve | | Opens between 1100 lb/sq. in. (77.34 kg/sq. cm.) and 1200 lb/sq. in. (84.37 kg/sq. cm.). |

Fault Diagnosis

(For quick reference chart see Page N49 and onwards)

Pump noise

The power steering pump is not completely noiseless. Some noise may be present whenever the wheels are on full lock. The noise usually becomes greater as engine speed is increased as is the case when the car is making a full lock turn. The noise is caused by the system relief valve and is normal.

Momentary aeration of the fluid is sometimes noticeable under these conditions. Some noise may also be present under parking conditions.

Power steering pump noise can be confused with noises from other units of the car. To determine whether excessive noise is present in the pump, start the engine and increase the engine speed to 1000 r.p.m. A medium pitch 'moan' is emitted from the pump which lowers in tone and increases in volume as the steering column is loaded, i.e. the road wheels are turned toward lock; this is normal. The engine r.p.m. decreases also as the road wheels are turned from the straight ahead position. This is normal. As the refrigeration compressor is driven from the same belts, it will be necessary to determine whether or not the noise is to be found in the compressor, this can be achieved by engaging and disengaging the compressor clutch.

If it is determined that the excessive noise is present in the steering pump, the following steps should be taken in the order given.

1. Check the driving belts for correct tensioning
2. Check the fluid level, filling to the required level if necessary.
3. Check that the run of the hoses is correct.
4. Check for presence of air in the fluid. Air will show up as bubbles or, the fluid will appear frothy or tan coloured. Small amounts of air can cause extremely noisy operation. If air is present—
 - (i) Check all fittings and bolts for tightness.
 - (ii) Check the entire system for the source of the air leak. Air can leak into the system at any place but usually occurs at hoses or pipe connections or, at the drive-shaft seal.

After each step in an attempt to eliminate air from the system, the pump should be operated at idle speed while the road wheels are turned occasionally from lock-to-lock.

5. If after step (4) there is no air present, insert a pressure gauge in the high pressure line between the steering pump and steering box. If, when increasing the engine speed to 1000 r.p.m. with the front wheels straight-ahead and without turning the steering wheel, the fluid pressure exceeds 125 lb/sq. in. (8.79 kg/sq. cm.) it will be necessary to remove the pump from the car then dismantle and inspect it as outlined under 'Pump—To inspect'.

Chapter N

Pump leakage

1. Tighten all fittings and bolts.
2. Try to determine the source of leakage by cleaning the exterior of the pump assembly.
3. Possible sources of pump leakage are as follows:

| SOURCE OF LEAKAGE | CAUSE | REMEDY |
|-----------------------------------|---|---|
| Top of reservoir. | Reservoir too full. Excessive air present in fluid. | Adjust to correct level. Proceed as in 1(d) under 'Pump Noise'. |
| At reservoir. | 'O'-ring damaged or incorrectly fitted. | Renew 'O'-ring and fit correctly. |
| At the pressure fitting or bolts. | Not tightened sufficiently. Cross-threaded fitting or defective seal on fitting or hose, or damaged seals. | Torque tighten to between 25 lb. ft. and 40 lb. ft. (3,46 kg.m. and 5,53 kg.m.). Correct where necessary. |
| At shaft seal. | Defective seal or damaged shaft. | Renew seal. Renew shaft if seal surface is scratched or damaged. |
| Leakage from metal parts. | Defective casting or reservoir. | Renew defective part. |

Power assistance poor or negligible or pump inoperative

1. Check driving belt(s) tension.
2. Check and fill the pump reservoir and bleed the steering system.
3. Determine the source of fault, i.e. the pump, steering box or hoses. Fit the pressure gauge in the pressure line between the steering pump and steering box.

First test—fluid circuit open

1. Apply the handbrake, start the engine then, turn the steering wheel through full turns from lock-to-lock holding the wheels momentarily against each lock stop and note the pressure on the gauge. This maximum pressure reading should not be less than 665 lb/sq. in. (46,75 kg/sq. cm.) with the engine idling at 500 r.p.m. (refrigeration system switched off), the gear selector in 'P' or 'N' position and the fluid temperature

in the reservoir between 150°F. (65.6°C.) and 170°F. (76.7°C.) (normal operating temperature).

Note To obtain the fluid temperature required for this test, turn the wheels from lock-to-lock several times.

Do not hold the wheels against their respective lock-stops for any extended period of time.

If the maximum pressure is below specification, this indicates that a fault is present in the hydraulic circuit. To determine whether the fault lies in the pump or control valve, proceed with the second test. It will not be necessary to proceed with the second test if the pressure differential between each full lock is more than 40 lb/sq. in. (2,81 kg/sq. cm.), since this indicates that the steering box valve is at fault.

Second test—fluid circuit closed

1. Apply the handbrake, run the engine at idle speed (500 r.p.m.), the gear lever in 'P' or 'N' position and the refrigeration system switched off.
2. Turn the valve of the gauge to the closed position.
Note The gauge cut-off valve must be located between the gauge and steering box.
3. Observe and compare the maximum pump pressure at idle. It should not be less than that specified.

Test comparison

By comparing the reading in 3 above, it is possible to determine whether the fault lies in the pump or steering box or both.

If the **first test** is **below** specification, and the **second test** is **equal or greater** to the specification, the steering box is at fault.

If the **first test** is **below** specification, and the second test is not more than 50 lb/sq. in. (3,5 kg/sq. cm.) greater, the steering pump is at fault and a full inspection of the pump is necessary.

If the steering box is at fault, refer to Section N5—The Steering Box for overhaul procedure.

Section N5

THE STEERING BOX (all cars)

Overhaul

Introduction

A higher ratio steering box is now fitted to **right-hand drive cars** having the following number and onwards.

Standard cars 4315—Coachbuilt cars 5023.

The difference in ratio is as follows:

Early cars 22.5:1—Later cars 19.3:1.

The servicing of both types of box is similar although there are minor changes to certain internal parts. This means that some parts usually provided as matched sets are not interchangeable, although the complete unit is interchangeable. Always refer to the current parts list for differences and available parts.

Steering box rocker shaft seal— To remove (steering box in position)

1. Place the car on a ramp or over a pit.
2. Remove the pendulum lever as described in 'Steering box—To remove'.
3. Remove the rocking shaft seal retaining ring.
4. Place a container under the steering box to catch the steering box fluid. Start the engine and turn the steering wheel to full right-hand lock (right-hand drive cars) left-hand lock (left-hand drive cars); fluid pressure will force the seals and backing washers out of the steering box housing. To prevent fluid loss and steering pump wear do not hold the steering wheel in the full lock position for more than a few seconds at a time. Stop the engine as soon as the seals are forced out; inspect the seals for damage.
5. If the outside diameter of the seal is scored inspect the internal bore of the steering box housing for burrs and if necessary remove them using a fine emery stone.

Steering box rocker shaft seal—To fit (steering box in position)

1. Thoroughly wash the rocking shaft bore and splines to remove any particles of dirt or metal.
2. Wrap one layer of tape around the rocking shaft splines to prevent damage to the seals as they are fitted.

3. Lubricate the rocking shaft bore and single lip seal with power steering fluid.

4. Fit the seal into the rocking shaft bore (see Fig. N29) using seal fitting tool (RH 7779). Do not drive the seal more than $\frac{1}{8}$ in. (3,18 mm.) above the lip of the rocking shaft bore.

5. Remove the seal fitting tool and place one of the steel backing washers over the shaft; drive the seal a further $\frac{1}{8}$ in. (12,7 mm.) into the rocking shaft bore.

6. Lubricate the double lip seal with power steering fluid and fit over the rocking shaft.

7. Drive the seal into the rocking shaft bore until the bottom of the seal is flush with the retaining ring groove.

8. Place the other steel backing washer and the retaining ring in the rocking shaft bore.

9. Drive both seals up into the rocking shaft bore until the circlip locates in the circlip groove.

Note Do not drive the seals further than is necessary for the circlip to engage with the circlip groove.

Steering box—To remove

1. Place the car on a ramp or over a pit.
2. Disconnect the battery.
3. Using a syringe drain the steering pump (both types) taking care not to damage the filter support plate (Hobourn Eaton pump only).
4. Remove the two flexible hoses from the upper section of the steering box housing; blank the hose ends and the steering box ports against the ingress of dirt.
5. On left-hand drive cars disconnect the hoses from the two steering box extension pipes.

Note A certain amount of fluid will drain from the two hoses when they are disconnected from the steering box.
6. Remove the front exhaust pipe and silencer assembly.

Chapter N

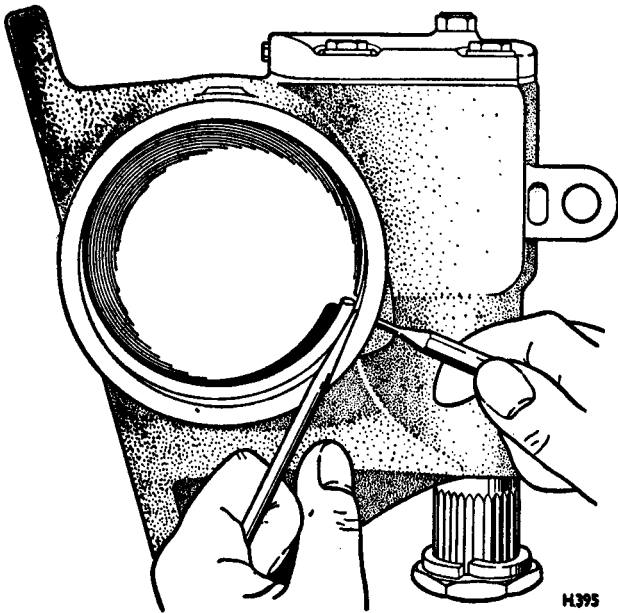

FIG. N23 REMOVING END PLUG RETAINING RING

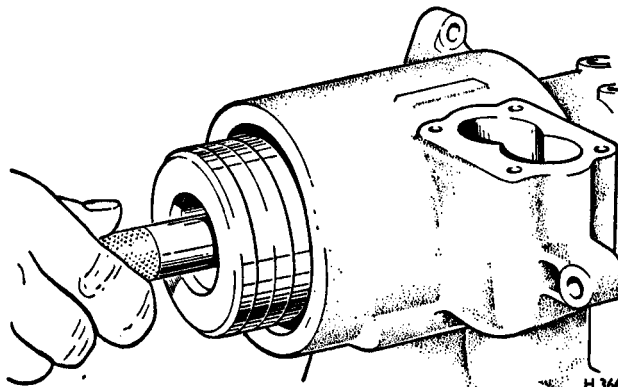

FIG. N24 INSTALLING RACK-PISTON ARBOR TOOL IN END OF WORM

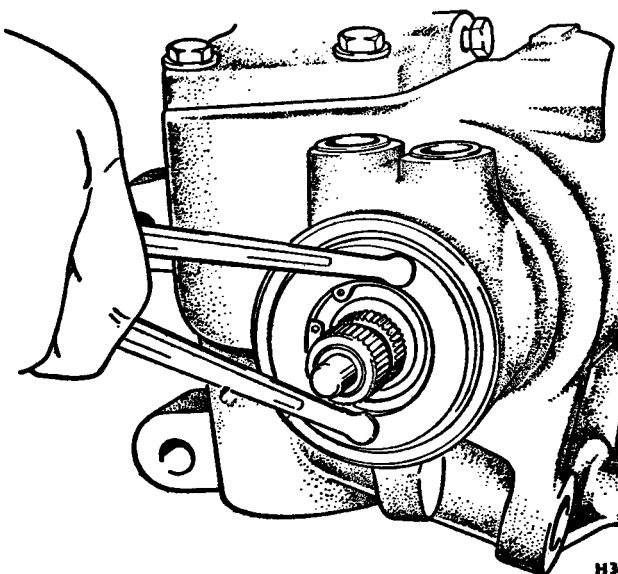

FIG. N25 REMOVING ADJUSTER PLUG ASSEMBLY

7. Remove the lower steering column assembly (see 'Lower steering column assembly—To remove').

8. Support the engine with either a sling or a jack and wooden pad.

9. Remove the two nuts and washers securing the engine front mounting.

10. Remove the nuts and bolts securing the steering box pipes to the engine front cross-member.

11. Remove the split pin and nut from the pendulum lever joint on the steering cross-beam then, using extractor (RH 8100), partially extract the ball pin from the lever.

12. Remove the nut securing the pendulum lever to the rocking shaft; remove pendulum lever using extractor (RH 8023).

13. Remove the four bolts, nuts and washers securing the engine cross-member to the steering box and the steering idler/damper housing; remove the cross-member.

14. Remove the three setscrews and washers securing the steering box to the front suspension sub-frame. Remove the steering box.

Steering box—Removal of major components

1. Position the steering box assembly in a vice with the end plug facing upwards.

2. Rotate the end plug retaining ring so that one end of the ring is over the hole in the housing. Spring one end of the ring with a punch to allow a screwdriver to be inserted and lift the ring out (see Fig. N23).

3. Rotate the stub shaft anti-clockwise (left-hand drive cars) and clockwise (right-hand drive cars), until the rack-piston just forces the end plug out of the housing.

Note Do not rotate the flange any further than necessary otherwise the balls will fall out of their circuit and the rocker shaft teeth and rack-piston will become disengaged.

Remove the end plug and discard the 'O' ring.

5. Remove the rack-piston end plug using a $\frac{1}{2}$ in. (1.27 cm.) square drive.

Note To facilitate removal, tap the rack-piston end plug with a mallet to unseat the threads. This is important as the end plug is torque tightened to 50 lb. ft. (6.9 kg.m.) during initial assembly and could break during removal if not handled carefully.

6. Remove and discard the lock-nut from the rocking shaft adjuster screw.

7. Remove the four screws and lock washers which secure the rocking shaft cover to the housing.

8. Rotate the rocking shaft adjuster screw with an Allen key until the rocking shaft cover is lifted from the housing.

9. Separate the rocking shaft cover from the rocking shaft. Discard the rocking shaft cover 'O' ring seal.

10. Turn the coupling flange until the rocking shaft teeth are centred in the housing.

11. Tap the end of the rocking shaft with a soft mallet and slide the rocking shaft out of the housing.

12. Insert Rack-piston Arbor (RH 7787), into the rack-piston against the end of the worm shaft. Turn the coupling flange anti-clockwise, (left-hand drive cars) and clockwise (right-hand drive cars) while holding the tool tightly against the worm to force the rack-piston on to the arbor, then remove the rack-piston from the gear housing (see Fig. N24).

13. Remove the screw retaining the stub shaft to the coupling flange and remove the coupling flange assembly.

14. Wrap the splines with one thickness of tape.

15. Remove the adjuster plug lock-nut by breaking it loose with a hammer and punch, then remove the lock-nut from the housing.

16. Unscrew the adjuster plug assembly, using Wrench (RH 7788) (see Fig. N25), and remove the adjuster plug assembly together with the valve assembly by pulling out the stub shaft.

17. Remove the worm, the lower thrust bearing, and the races from the upper end of the housing.

Steering box housing, rocking shaft needle bearing and seals— To dismantle

1. Remove the rocking shaft seal retaining ring from the steering box housing and withdraw the outer backing washer.

2. Insert a screwdriver between the outer seal and the inner backing washer then prise out the seal and remove the backing washer.

3. Insert a screwdriver between the inner seal and shoulder of the steering box housing and prise out the seal. Care must be taken to prevent damage to the seal bore. Discard the seals.

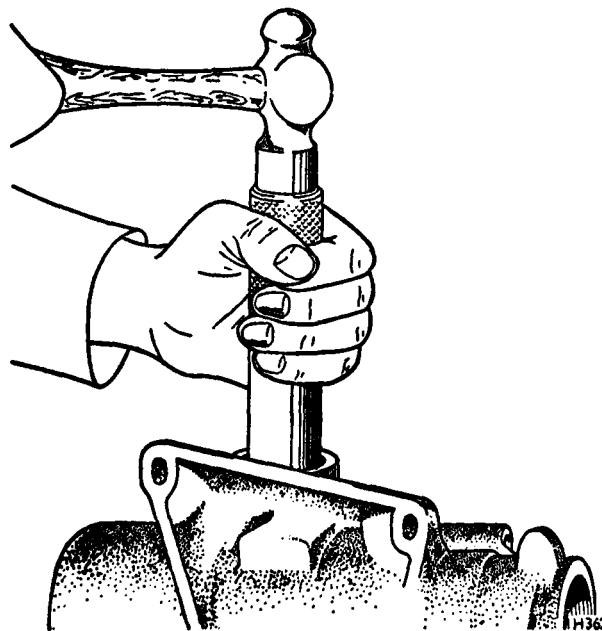

FIG. N26 REMOVING AND INSTALLING ROCKER SHAFT BEARING

4. Inspect the rocking shaft needle bearing and if the rollers are broken or pitted, remove the needle bearing from the steering box housing using the rocking shaft bearing extraction and insertion tool (RH 7781) (see Fig. N26).

Steering box housing rocking shaft needle bearings and seals—To inspect

1. Inspect the housing bore. If badly scored or worn, renew the housing.

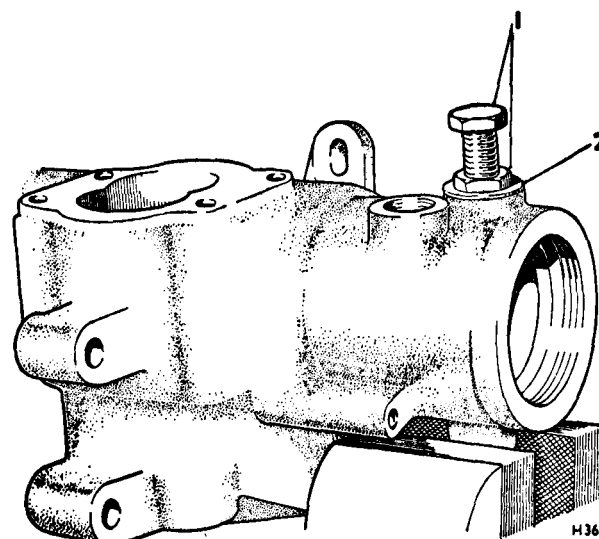

FIG. N27 REMOVING HOSE CONNECTOR SEAT WITH BOLT

1 $\frac{5}{16}$ in. bolt and nut 2 Flat washer

Chapter N

2. Inspect the high and low pressure line hose connector seats, the poppet valve and seat in the steering box housing. Renew if they are badly scored, cracked or distorted.

3. Inspect the ball plug in the valve body end of the housing. If it is leaking or raised above the surface it should be seated flush or $\frac{1}{16}$ in. (1,59 mm.) below the surface. Lightly peen over the end of the bore to secure the ball.

4. Inspect all retaining ring grooves and seal surfaces for damage or failure.

Hose connectors—To remove

1. To prevent metal particles from becoming lodged in the valve assembly, pack the inside of the connector seat with petroleum jelly

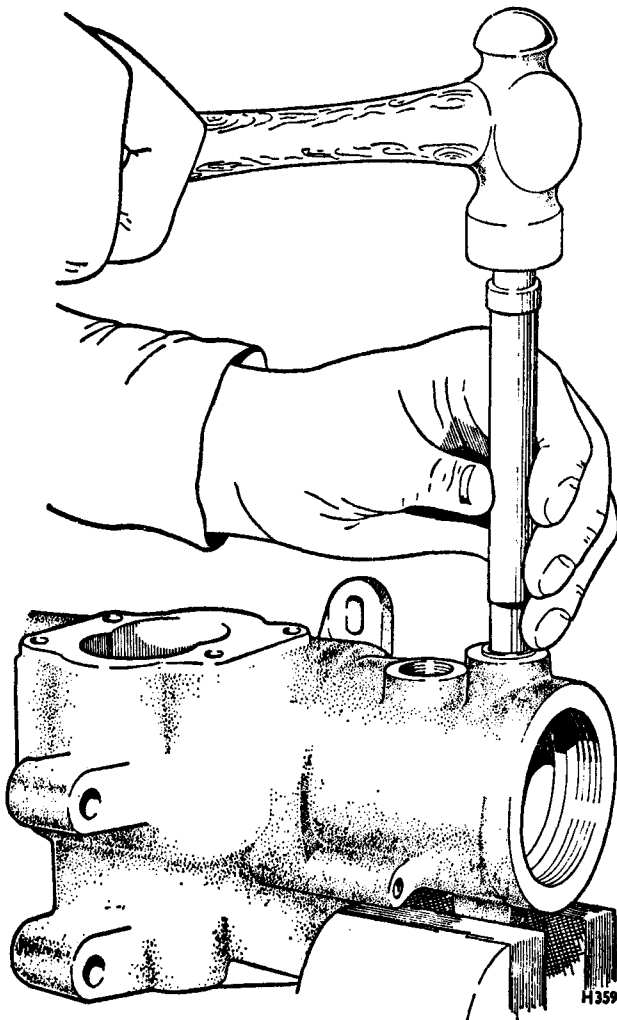

FIG. N28 INSTALLING HOSE CONNECTOR SEAT

2. Tap threads in the connector seats using a $\frac{5}{16}$ in. thread tap.

Note Do not tap threads too deeply in the pressure hose connector seat as the tap will bottom the poppet valve against the housing and damage it. It is necessary to tap only 2 or 3 threads deep.

3. Insert a $\frac{5}{16}$ in. threaded bolt with a nut and suitable flat washer into the tapped hole (see Fig. N27).

4. To extract the connector seat, prevent the bolt from rotating while screwing the nut off the bolt. This will extract the connector from the housing. Discard the connector seat.

5. Remove and discard the poppet valve and spring from the pressure port.

6. Wipe all the petroleum jelly from the housing and clean the housing thoroughly to remove any metal swarf or dirt.

7. Insert a new poppet valve spring in the pressure port with its large end downwards.

8. Make sure the spring is seated in the counter-bore in the pressure port. Insert a new poppet valve over the spring with its tangs pointing downwards. Make sure that the valve is centred on the small end of the spring.

9. Fit new connector seats using petroleum jelly to hold the connector seat on the poppet valve in the pressure port. Bed the connector seats lightly in place using valve connector seat insertion tool (RH 7786) (see Fig. N28).

10. Check the operation of the valve by pushing lightly against the valve with a pencil point or small rod. The valve should re-seat itself against the connector seat when the rod is removed.

Steering box housing rocking shaft needle and bearing seals—To assemble

1. Thoroughly clean all the components and lubricate them with the approved power steering fluid.

2. If the rocking shaft needle bearing was previously removed fit new bearings on the end of the rocking shaft bearing extraction and insertion tool (RH 7781) with the letters on the bearing against the tool. Position the bearing and tool in the housing and drive the bearing into the housing (see Fig. N26). The upper edge of the bearing should be approximately 0.03 in. (0,762 mm.) below the shoulder in the bore of the housing.

3. Lubricate the rocking shaft bore and single lip rocking shaft seal with the approved power steering fluid and insert the seal into the bore using the rocking shaft seal insertion tool (RH 7779) (see Fig. N29). Do not drive the seal more than $\frac{1}{8}$ in. (3,18 mm.) below the face of the housing.

4. Remove the insertion tool and place a steel washer on top of the seal. Using insertion tool (RH 7779) drive the seal approximately $\frac{1}{2}$ in. (12,7 mm.) further into the bore.

5. Lubricate the double lip seal with the approved power steering fluid and insert it into the bore (see Fig. N29). Using rocking shaft seal insertion tool (RH 7779) drive the seal into the bore until the top edge of the seal is flush with the bottom edge of the circlip groove.

6. Remove the seal insertion tool and place a steel washer and circlip over the seal. Using the seal insertion tool drive both seals down into the bore until the circlip seats into the circlip groove.

Note In order to avoid possible damage to the sealing surface of the lower seal, it is important that the seals and washers are driven down only far enough to allow the circlip to seat into the ring groove.

Adjuster plug assembly—To dismantle

1. Remove the thrust bearing retainer with a screwdriver (see Fig. N30), taking care not to score the needle bearing bore, discard the thrust bearing retainer.
2. Remove the thrust bearing spacer, thrust bearing and bearing races.
3. Remove and discard the adjuster plug 'O' ring seal.
4. Remove the stub shaft seal retaining circlip.
5. Remove and discard the combination washer, dust seal and stub shaft fluid seal.

Adjuster plug assembly—To inspect

1. Inspect the needle bearing in the adjuster plug. If the rollers are broken or pitted, remove the needle bearing by pressing out from the thrust bearing end, using the adjuster plug bearing extraction and insertion tool (RH 7783) (see Fig. N31).
2. Inspect the thrust bearing spacer for cracks.
3. Inspect the thrust bearing rollers for signs of wear, pitting, scoring or cracking. If any of these conditions are found, renew the thrust bearing, bearing races and check the condition of the thrust bearing spacer.

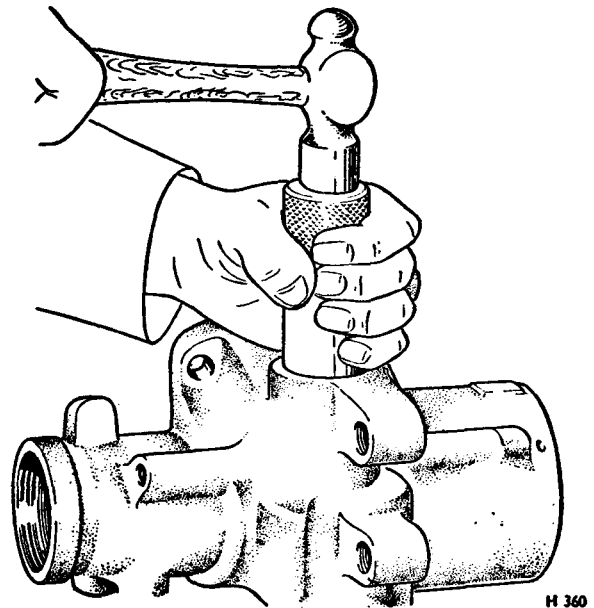

FIG. N29 INSTALLING ROCKER SHAFT SEAL

Adjuster plug assembly—To assemble

1. If the adjuster plug needle bearing was previously removed, fit a new needle bearing on to the adjuster plug bearing extraction and insertion tool (RH 7783) with the letters on the bearing against the tool.
2. Position the bearing and tool over the thrust bearing end of the plug and drive the bearing into the plug (see Fig. N31). The end of the bearing must be flush with the bottom surface of the stub shaft seal bore.
3. Lubricate the new stub shaft fluid seal with the approved power steering fluid and, using adjuster plug seal insertion tool (RH 7780) (see Fig. N32) install the seal far enough to provide clearance for the dust seal and retaining ring.

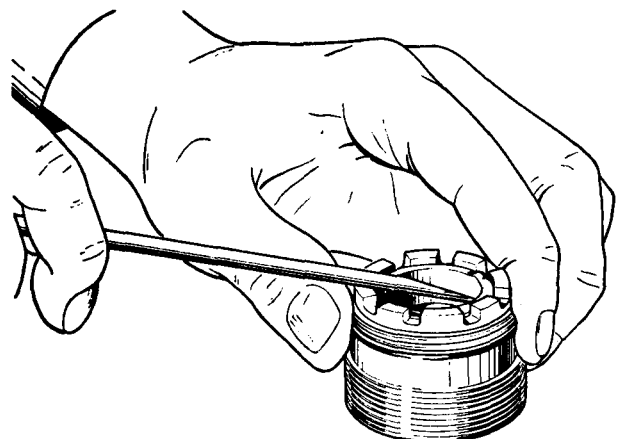

FIG. N30 REMOVING THRUST BEARING RETAINER

Chapter N

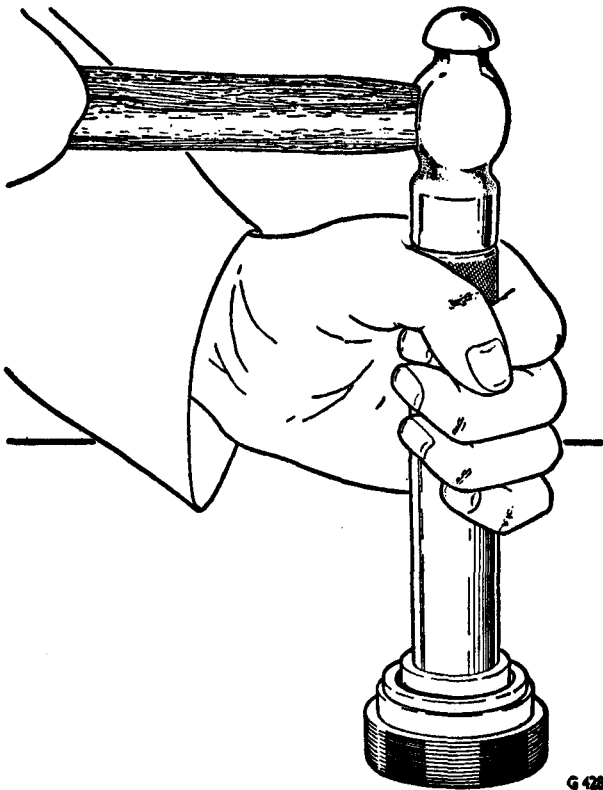

FIG. N31 REMOVING AND INSTALLING ADJUSTER PLUG NEEDLE BEARING

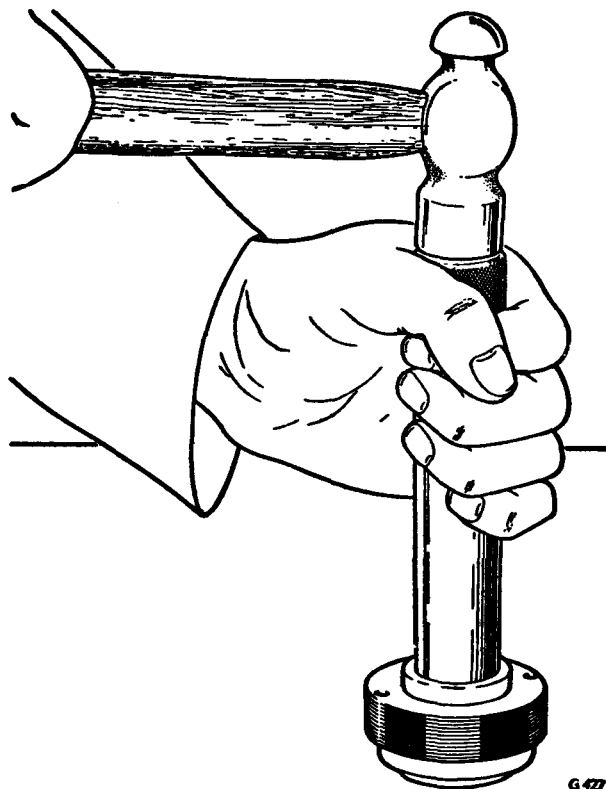

FIG. N32 INSTALLING OIL SEAL

4. Lubricate the new dust seal with the approved power steering fluid and install in the plug with the rubber face outward.

5. Fit the retaining circlip, making certain that it is correctly seated.

6. Lubricate the new 'O' ring seal with the approved power steering fluid and fit it in the groove on the adjuster plug.

7. Assemble the large outside diameter thrust race and thrust bearing, small thrust race, and thrust bearing spacer on the adjuster plug. Press the needle bearing into the needle bearing bore using a brass drift.

Note Location of circumferential dimples is not important.

Stub shaft and valve

1. The complete valve assembly is a precision unit with selectively fitted parts and is hydraulically balanced during assembly. If replacement of any valve part other than rings and seals is necessary, the complete rotary valve assembly must be renewed as a unit.

To avoid the possibility of damage to the assembly, do not dismantle the valve unless absolutely necessary.

2. If the valve spool damping 'O' ring requires replacement, remove the valve spool as described in the following paragraphs, renew the 'O' ring and fit the spool.

Stub shaft and valve—To dismantle

1. Remove and discard the worm to cap 'O' ring.

2. Remove the spool spring, using a small screwdriver.

3. Ease the spring on to the bearing diameter of the stub shaft then slide the spring off the stub shaft. **Do not score the bearing surface.**

4. Remove the valve spool from the valve body.

Note Clearance between the valve body and spool may be as low as 0.0004 in. (0.010 mm.). Slight cocking of the spring may cause it to stick in the valve body.

5. To remove the valve spool hold the valve assembly in both hands with the stub shaft pointing downwards. Place the fingers under the valve body and thumbs on the valve body cap, holding it securely against the valve body. Lightly tap the end of the torsion bar against a work bench. This will expose the spool sufficiently to enable it to be withdrawn from the valve body. Withdraw the spool with a

steady twisting pull to prevent jamming. If slight sticking occurs, carefully work the spool back into the valve body. If this does not free the spool it has become cocked in the valve body bore, and no attempt should be made to force the spool in or out. Continue to dismantle the valve assembly as follows and remove the spool as described later.

6. Remove the stub shaft, torsion bar, and valve cap assembly by holding the valve assembly in both hands as before, only with the thumbs on the valve body. Lightly tap the torsion bar against a work bench. This will dislodge the cap from the valve body-to-cap pin. The stub shaft torsion bar and valve cap assembly can now be removed from the valve body.

7. If the valve spool has become cocked as described earlier, it can now be freed. Visual inspection on a flat surface will show in which direction the spool is cocked. A few very light taps with a light hide mallet should align the spool in the bore and free it.

Note Do not tap the spool with anything metallic.

Stub shaft and valve—To inspect

1. If there is evidence that the torsion bar 'O' ring seal inside the stub shaft has been leaking, the entire valve assembly should be renewed.
2. Check the pin in the valve body that engages the cap. If it is severely worn, cracked or broken, the entire valve assembly should be renewed.
3. Check the smaller of the two worm pin grooves in the valve body. If this is severely worn, the entire valve assembly should be renewed.
4. Check the spool drive pin on the stub shaft. If it is severely worn, cracked or broken, the entire valve assembly should be renewed.
5. Examine the spool outside diameter for nicks, burrs, or badly worn spots. If evidence of any of these is found, the entire valve assembly should be renewed. A slight polishing effect on valve surfaces is normal.
6. Check the fit of the spool in the valve body before inserting the valve spool damping 'O' ring seal.
7. When lubricated with the approved power steering fluid the spool should rotate freely. If binding or catching occurs the entire valve assembly should be renewed.
8. Measure the length of the spool spring; the free length should be 0.83 in. (21.0 mm.). The inner diameter of the top loop of the spring should be between 0.76 in. and 0.8 in. (19.44 mm. and 20.24 mm.). Renew the spring if the measurements are not as specified.

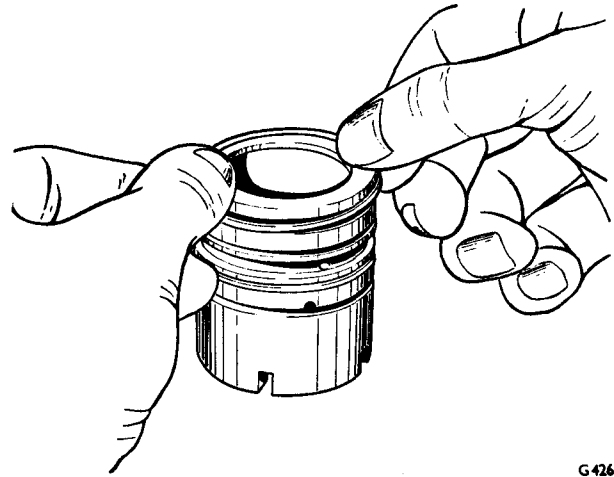

G 426

FIG. N33 INSTALLING VALVE RING

9. Examine the needle bearing diameter of the stub shaft. If it is badly worn or scored, the entire valve assembly should be renewed.

10. Examine the valve body rings, if damaged, carefully cut the valve rings and 'O' ring backing seals. Remove and discard them.

Stub shaft and valve—To assemble

1. If new valve body ring backing 'O' rings seals are necessary lubricate them with the approved power steering fluid and fit them in the ring grooves on the valve body. Do not allow the seals to become twisted. If new valve body rings are necessary, lubricate them with the approved power steering fluid and fit the valve rings in the ring grooves over the backing 'O' ring seals by carefully slipping the rings over the valve body (see Fig. N33). The rings may appear to be loose in the grooves, but the heat of the fluid after assembly will cause them to tighten.

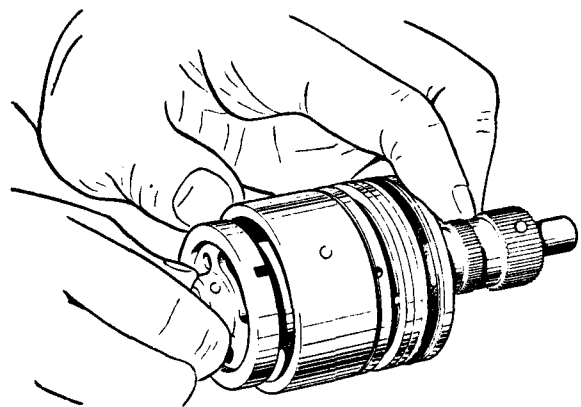

G 425

FIG. N34 INSTALLING STUB SHAFT IN VALVE BODY

Chapter N

2. Lubricate the new valve spool damping 'O' ring seal with the approved power steering fluid and insert the seal into the valve spool groove.

3. Insert the stub shaft into the valve body, aligning the groove in the valve cap with the pin in the valve body (see Fig. N34). Tap lightly on the cap with a hide mallet until the cap is against the shoulder in the valve body, with the valve body pin in the cap groove. Hold these parts together during the remainder of the assembly procedure.

4. Lubricate the valve spool with the approved power steering fluid and slide the spool over the stub shaft with the notch towards the valve body. Align the notch with the spool drive pin in the cap groove stub and carefully engage the spool in the valve body bore.

Note Because the clearance between the spool and valve body is very fine, extreme care must be taken when assembling these parts. Push the spool evenly and slowly, with a slight twisting motion, until it reaches the drive pin. Rotate the spool slowly with pressure until the notch engages the pin. Before pushing the spool completely in, make sure that the damping 'O' ring seal is evenly distributed in the spool groove. Slowly push the spool completely in, taking care not to cut or pinch the 'O' ring seal by inserting the spool beyond its normal position.

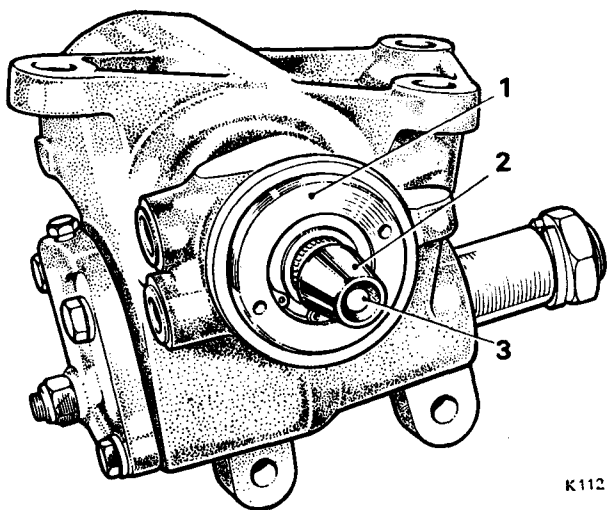

FIG. N35 INSTALLING ADJUSTER PLUG ASSEMBLY

- 1 Adjuster plug assembly
- 2 Seal protector
- 3 Stub shaft

5. Slide the spool spring over the stub shaft and, using a small screwdriver, ease the spool spring down until it is seated in the stub shaft groove.

6. Lubricate the new cap-to-worm 'O' ring seal with the approved power steering fluid and insert it into the valve body.

Note Do not fit the upper thrust bearing assembly to the valve assembly at this stage.

Rocking shaft gear and rocking shaft cover— To inspect

1. Inspect the rocking shaft bearing surface in the rocking shaft cover for excessive wear or scoring. If badly worn or scored, renew the rocking shaft cover.
2. Examine the rocking shaft sector teeth and bearing and the seal surface. If excessively worn, pitted or scored, renew the rocking shaft.
3. Check the rocking shaft for excessive wear or for a broken spring as follows.
4. Clamp the rocking shaft in a vice.
5. Using a torque wrench with a $\frac{7}{8}$ in. (5,56 mm.) Allen key, measure the torque required to turn the adjuster screw. The torque reading should be between 1 lb. in. and 5 lb. in. (0,012 kg.m. and 0,173 kg.m.). If the reading is not within this range, the rocking shaft must be renewed.

Rack—piston and worm assembly— To dismantle

1. Remove the return guide clamp screws and remove the clamp.
2. Place the assembly on a clean cloth and remove the ball return guides and rack-piston arbor (RH 7787). Make sure that all the 22 balls are caught in the cloth.

Rack-piston and worm assembly— To inspect

1. Inspect the worm and rack-piston grooves and all the balls for excessive wear or scoring. If either the worm or the rack-piston require renewal, both must be renewed as a matched assembly.
2. Inspect the ball return guides, ensuring that the ends where the balls enter and leave the guide are not damaged.
3. Inspect the lower thrust bearing and races for wear, pitting, scoring or cracking. If any of these conditions are found renew the thrust bearing and races and check the worm shaft.

Chapter N

4. Inspect the rack-piston and end plug to ensure that the threads are not damaged.
5. Inspect the rack-piston teeth and rack-piston outside diameter for abnormal wear, scoring or burrs.
6. Examine the piston ring; if damaged, remove and discard the ring and backing 'O' ring seal.

Rack-piston and worm assembly— To assemble

1. Thoroughly clean the parts and lubricate them with the approved power steering fluid.
2. Lubricate the new backing 'O' ring seal and insert it in the piston ring groove on the rack-piston. Do not allow the seal to become twisted. Fit the new piston ring into the groove over the 'O' ring seal.
3. Insert the worm into the end of the rack-piston, from the end opposite the piston ring, until the worm is against the rack-piston shoulder.
4. Load 16 balls into the guide hole nearest to the piston ring while rotating the worm anti-clockwise to feed the balls through the circuit. Alternate black balls with white balls throughout the circuit.
5. Apply a liberal amount of petroleum jelly to one ball return guide and load the remaining 6 balls into the guide. Place the outer guide over the balls and ball guide and insert the guides into the guide holes of the rack-piston. Ensure that black ball in the guide is installed next to the white ball in the rack-piston. The guides should fit loosely.
6. Place the return guide clamp over the guides and secure it with two screws and lockwashers; torque tighten to 12 lb. ft. (1,66 kg.m.).

The worm groove is ground with a high point in the centre. When the rack-piston passes over this high point a load of between 1 lb. in. and 4 lb. in. (0,12 kg.m. and 0,46 kg.m.) should be obtained. To measure

the pre-load of the worm and rack-piston ball assembly proceed as follows.

7. Clamp the rack-piston in a suitably protected vice with the worm shaft pointing upwards. Do not distort the rack-piston by over-tightening the vice.

8. Place the valve assembly on the worm shaft, engaging the worm shaft drive pin. Rotate the worm shaft until it extends 1.25 in. (3,17 cm.) from the rack-piston to the thrust bearing face. This is the centre position.

9. Apply a torque wrench with $\frac{3}{4}$ in. (19,05 mm.) socket to the stub shaft and rotate the wrench several times through an arc of approximately 60° in both directions then take a torque reading. The highest average reading obtained with the worm rotating should be between 1 lb. in. and 4 lb. in. (0,012 kg.m. and 0,046 kg.m.).

If the reading is below 1 lb. in. (0,012 kg.m.) a new set of balls must be fitted. Service replacement balls are available in sizes listed in the following chart.

Note the ball size stamped on the rack-piston and fit the next size larger balls to increase the pre-load.

Note If a number cannot be found on the rack-piston, the original ball size was 7.

A change of one ball size (higher size code) will increase the pre-load approximately 1 lb. in. (0,012 kg.m.). Final pre-load on replacement balls should be between 2 lb. in. and 3 lb. in. (0,023 kg.m. and 0,035 kg.m.).

10. Remove the valve assembly from the worm.
11. Remove the rack-piston from the vice.

12. Insert the rack-piston arbor until it registers against the worm shaft and turn the rack-piston on to the arbor. Do not allow the arbor to separate from the worm shaft until the rack-piston is fully on the arbor.

Piston ball sizes

| SIZE CODE | MEAN DIA. | SIZE RANGE OF BALL |
|-----------|---------------------------|---|
| 7 | 0.28125 in. (0,71437 cm.) | 0.28120–0.28130 in. (0,71425 cm.–0,71450 cm.) |
| 8 | 0.28133 in. (0,71457 cm.) | 0.28128–0.28138 in. (0,71427 cm.–0,71452 cm.) |
| 9 | 0.28141 in. (0,71486 cm.) | 0.28136–0.28146 in. (0,71451 cm.–0,71490 cm.) |
| 10 | 0.28149 in. (0,71498 cm.) | 0.28144–0.28154 in. (0,71485 cm.–0,71511 cm.) |

Chapter N

Steering box—To assemble

1. Position the steering box housing in a protected vice with the adjuster plug end facing upwards.
2. Lubricate the worm shaft, lower thrust bearing, and races with the approved power steering fluid then position the thrust bearing and races on the worm shaft.
3. Align the valve body drive pin on the worm shaft with the narrow pin slot on the valve body. Ensure that the 'O' ring seal is fitted between the valve body and the worm head.
4. Position the valve assembly and worm shaft in the housing as an integral unit.

Note Do not push against the stub shaft as this may cause the stub shaft and cap to pull out the valve body, allowing the spool seal to slip into the valve body fluid grooves. The valve assembly can be installed by pushing on the outer diameter of the valve body housing with the fingers of both hands. Ensure that the white plastic rings are not binding on the inside of the housing. The valve assembly is correctly seated when the fluid return in the housing is fully visible.
5. Place the adjuster plug seal protector (RH 7782) over the end of the stub shaft.

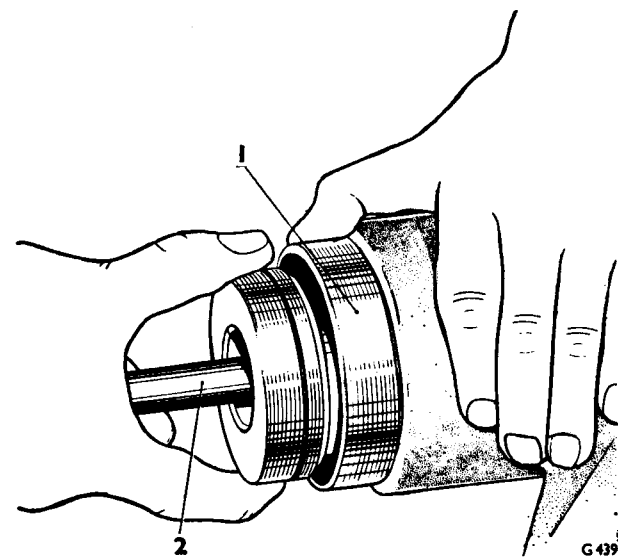

FIG. N36 INSTALLING RACK-PISTON SEAL COMPRESSOR

1 Seal compressor 2 Rack-piston arbor

6. Fit the adjuster plug assembly over the end of the stub shaft (*see Fig. N35*), and tighten just sufficiently to make certain that all parts are correctly seated in the housing. Remove the seal protector (RH 7782).

Note If the seal protector (RH 7782) is removed too soon, the stub shaft seal will be damaged by the shaft splines.

7. Fit the adjuster plug lock-nut loosely on the adjuster plug.

Note Do not adjust the thrust bearing preload at this time.

8. Insert rack-piston seal compressor (RH 7785) into the steering box housing (*see Fig. N36*), holding it tightly against the shoulder in the housing.

9. Insert the rack-piston into the housing until the arbor engages with the worm. Turn the stub shaft clockwise using a $\frac{3}{4}$ in. (19,05 mm.) socket or box spanner to draw the rack-piston into the housing. When the piston ring is in the housing piston bore the rack-piston arbor (RH 7787) and the seal compressor (RH 7785) can be removed.

10. Turn the stub shaft as necessary until the middle rack groove in the rack-piston is aligned with the centre of the rocking shaft needle bearing. Lubricate the new side cover 'O' ring seal and fit it into the groove in the face of the side cover.

11. Secure the rocking shaft cover to the rocking shaft by screwing the cover to rocking shaft adjuster screw until the rocking shaft cover bottoms on the rocking shaft, then back off $\frac{1}{2}$ a turn.

12. Install the rocking shaft so that the centre tooth in the sector meshes with the centre groove of the rack-piston. Ensure that the rocking shaft cover 'O' ring is in place before pushing the side cover down on the steering box housing.

13. Fit the rocking shaft cover screws and lock washers and torque tighten to 30 lb. ft. (4,148 kg.m.). Hold the adjuster screw with an Allen key and fit the adjuster lock-nut halfway on to the adjuster screw.

14. Insert the rack-piston end plug into the rack-piston.

15. Torque tighten the end plug to 50 lb. ft. (6,91 kg.m.).

16. Lubricate the new end plug 'O' ring seal and insert it into the groove in the end plug.

17. Insert the end plug into the steering box housing and seat it against the 'O' ring seal. Light tapping with a mallet may be necessary to seat the end plug correctly.

18. Snap the end plug retainer ring into place by hand. Light tapping may be required to bottom the retainer ring securely in the steering box housing.

Chapter N

19. Position the gear assembly with the stub shaft end uppermost and adjust the thrust bearing pre-load as follows.

20. Using spanner-wrench (RH 7788), lightly tighten the adjuster plug and then back off $\frac{1}{8}$ of a turn.

21. Fit a 0 lb. in. to 25 lb. in. (0 kg.m. to 0,288 kg.m.) torque wrench with a $\frac{3}{4}$ in. (19,05 mm.) socket to the stub splines.

22. Rotate the stub shaft to either the left or right turn stop, then back off from the stop $\frac{1}{2}$ a turn.

23. Rotate the torque wrench in a 45° arc and note the highest reading. Tighten the adjuster plug with spanner wrench (RH 7788) until there is a pre-load of 1 lb. in. to 3 lb. in. (0,012 kg.m. to 0,035 kg.m.) higher than the initial load reading just measured.

24. Securely tighten the adjuster plug lock-nut with a punch and hammer.

25. Check the pre-load to ensure that it still reads 1 lb. in. to 3 lb. in. (0,012 kg.m. to 0,035 kg.m.) higher than the initial load.

26. Adjust the rocking shaft end play as described in Operations 27 to 30 inclusive.

27. Rotate the stub shaft from one stop to the other to locate the centre of travel.

28. With the steering box on centre, check the combined ball and thrust bearing pre-load with a torque wrench fitted with a $\frac{3}{4}$ in. (19,05 mm.) point socket and note the highest reading.

29. With the steering box on centre and the adjuster screw lock-nut backed off, adjust the rocking shaft so that pre-load is 8 lb. in. to 10 lb. in. (0,09 kg.m. to 0,12 kg.m.) in excess of the total pre-loading and drag.

Note These readings should be made by rotating the torque wrench in a 20° arc. The total pre-load of the steering box should not exceed 20 lb. in. (0,23 kg.m.).

30. With the steering box on centre and the correct reading achieved, torque tighten the adjuster screw lock-nut to 30 lb. ft. (4,15 kg.m.).

31. Fit the coupling flange assembly to the stub shaft and insert the flange screw to the coupling; torque tighten the screw to 30 lb. ft. (4,15 kgm.).

Steering box—To fit

1. Secure the steering box to the front suspension sub-frame with the three setscrews and washers.

2. Fit the front engine cross-member, lower the engine and tighten the front engine mounting nuts.

3. Connect the lower steering link splined coupling to the steering box input shaft and tighten the pinch

bolt. The coupling has an internal flat machined on the splines to correspond with a flat on the steering box input shaft and can only be fitted in one position.

4. Connect the upper steering column link to the main steering column assembly.

5. Turn the steering wheel to either full lock position and turn back approximately 2 $\frac{1}{2}$ turns.

6. Fit the pendulum lever (pointing to the rear of the car) to the rocking shaft; do not tighten the nut on the rocking shaft.

Note The pendulum lever can only be fitted to the rocking shaft in one position, this being determined by a number of master splines and the steering box 'tight spot' position.

7. To align the steering box 'tight spot' position with the road wheels refer to Section N6.

8. Fit the cross-beam ball joint to the pendulum lever and torque tighten the nut to between 29 lb. ft. and 32 lb. ft. (4,0 kg.m. and 4,4 kg.m.) and fit the split pin.

Note Do not slacken the nut to fit the split pin.

9. Connect the two flexible hoses to the ports in the steering box, ensuring that the pressure line is connected to the foremost port.

10. On left-hand drive cars fit the flexible hoses to the steering box extension pipes.

Important If the steering box or steering housing is disturbed at any time refer to 'Chapter H—Front suspension settings'.

11. Check the position of the steering wheel. If it is slightly mis-aligned in the 'straight-ahead' position slacken the two securing setscrews connecting the splined flange to the universal knuckle, and move the flange in the slots. Torque tighten the setscrews to between 29 lb. ft. and 32 lb. ft. (4,0 kg.m. and 4,4 kg.m.).

12. Ensure that the bolts securing the steering box to the front suspension sub-frame are torque tightened to between 42 lb. ft. and 45 lb. ft. (5,8 kg.m. and 6,2 kg.m.).

13. Fit the packing between the engine stop-plate and the engine if the steering box and damper are more than halfway down their slots.

14. Secure the front engine mount to the torque arm; the torque tightness of the two securing bolts should be 65 lb. ft. (8,98 kg.m.).

15. Check the level of the steering pump reservoir then prime the system as described previously.

Chapter IV

Checking steering box pre-load (steering box on car)

1. When the steering gear is thought to be out of adjustment a quick check can be made by moving the steering wheel to and fro with short slow motions at the 'on centre' position with the ignition switched off. Excessive looseness felt or heard indicates that either the rocking shaft or the thrust bearing requires adjustment. These adjustments can be made on the car by using the following procedure.

Thrust bearing pre-load check (2 turns off-centre)

1. Remove the pendulum lever from the cross-beam using pendulum lever puller (RH 8100).

2. Turn the steering wheel two turns 'off-centre'; just away from the stops, and use a spring tension gauge with a piece of wire or strong cord to measure the pull on the steering wheel rim through an arc not exceeding one inch (see Fig. N37). The total pull should be between 4 oz. and 12 oz. (0,113 kg. and 0,340 kg.) (thrust bearing and friction). If the 'off-centre' pull is greater or less than specified, loosen the adjuster plug lock-nut and back off the adjuster plug $\frac{1}{2}$ of a turn using a spanner wrench (RH 7788).

Note If the position of the holes in the adjuster plug is such that there is insufficient clearance for using the spanner wrench, insert a bolt $\frac{3}{4}$ in. (19 mm.) long in one of the adjuster plug holes and rotate the coupling flange until the lower flange contacts the bolt. Then back off the adjuster plug $\frac{1}{2}$ of a turn.

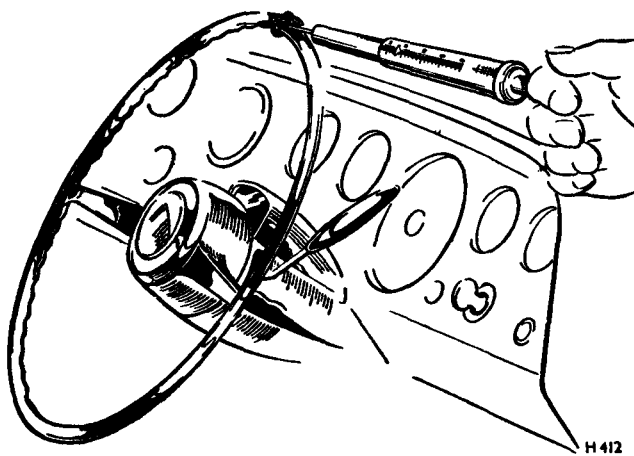

FIG. N37 CHECKING THE STEERING BOX PRE-LOAD

3. Recheck the steering wheel 'pull' with the wheel two turns 'off-centre'. Adjust the pre-load by tightening the adjuster plug to obtain 2 oz. to 6 oz. (0,056 kg. to 0,170 kg.) (at the rim of the wheel) in excess of the total drag that was just measured with the adjuster plug backed-off $\frac{1}{2}$ of a turn.

4. Tighten the adjuster plug lock-nut and recheck the pre-load to ensure the plug did not move when the nut was tightened.

Checking rocking shaft end play (On centre)

1. Find the exact centre of the steering wheel travel. The tight spot due to the rocking shaft should extend for $\frac{1}{2}$ of a turn to either side.

2. With the steering wheel 'on-centre' measure and record the total pull through an arc of three inches or less.

This reading should not be more than 36 oz. (1,02 kg.), but should be at least 8 oz. (0,226 kg.) but never more than 20 oz. (0,566 kg.) more than a reading taken $\frac{1}{2}$ a turn 'off-centre'.

Note On new steering boxes the factory setting with ball bearing pre-loads and new seal drag may cause a total pull to be as high as 40 oz. (1,13 kg.). Within the first 100 miles (160 km.) of operation the seals seat themselves and the ball bearings polish the rack-piston and worm shaft grooves sufficiently to meet the service specifications.

If the rocking shaft end play is not within limits, it should be adjusted so that 'on-centre' pre-load is between 16 oz. and 18 oz. (0,453 kg. and 0,510 kg.) more than the $\frac{1}{2}$ turn 'off-centre' load but still not more than 36 oz. (1,02 kg.).

3. Adjust the pre-load by loosening the lock-nut and turning the adjusting screws as required. Recheck the pull after tightening the lock-nut. Check for rough spots in the rocking shaft sector and power piston rack by turning the wheel a $\frac{1}{4}$ of a turn to the left and a $\frac{1}{4}$ of a turn to the right.

4. A visual inspection of the gear teeth will reveal necessary correction, if rough spots are found. Remember, however, that the teeth are not absolutely smooth, but are machined to hold lubricant.

5. When the steering adjustments are completed, remove the spring tension gauge and wire or cord connection. Then connect the pendulum lever to the cross-beam and tighten the cross-beam nut to between 35 lb. ft. and 40 lb. ft. (4,83 kg.m. and 5,33 kg.m.).

Section N6

STEERING LINKAGE

Overhaul

Steering linkage—To remove

1. Remove the split pins and nuts from the ball joints on the outer ends of the cross-tubes.
2. Using extractor tool (RH 8080) extract the cross-tubes outer ball pins from the side steering levers.
3. Remove the nut and washer which secure the pendulum lever to the steering box rocking shaft.
4. Unlock the tab washer and remove the nut and

washer securing the steering idler/damper lever to the idler/damper shaft.

Do not remove the idler/damper lever from the steering damper unless absolutely essential, otherwise the idler/damper will have to be partially dismantled to re-position it if a splined lever is not fitted.

5. Remove the linkage from the car.

Note When removing any part of the steering linkage ensure that the rubber seals are not accidentally damaged by trapping or impact.

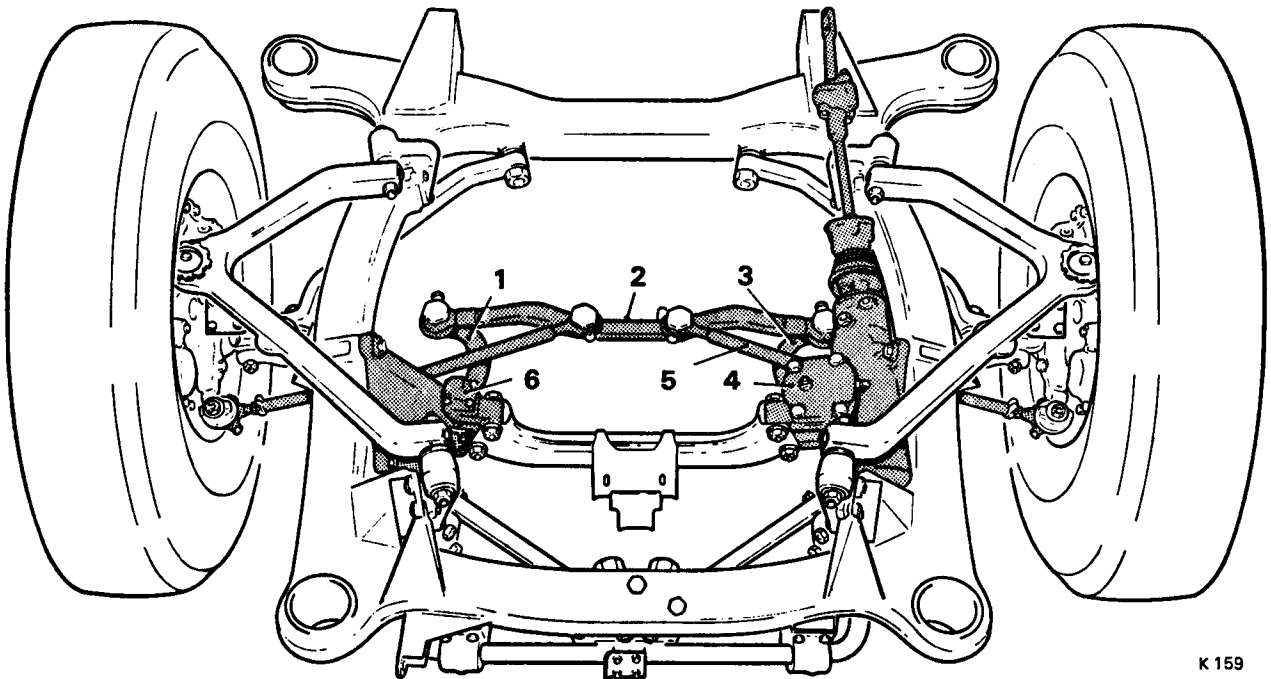

K 159

FIG. N38 STEERING LINKAGE AND IDLER/DAMPER

- | | | |
|---------------------|------------------|-------------------------|
| 1 Idler lever | 3 Pendulum lever | 5 Track rods |
| 2 Cross-beam member | 4 Steering box | 6 Steering idler/damper |

Chapter N

Steering linkage—To dismantle

1. The linkage can be readily dismantled by removing the split pins and nuts from the ball joints and extracting the pins from their sockets using extractor (RH 8080).

Ball joints—To renew

The ball joints are fitted with grease nipples and can be dismantled and renewed if necessary.

1. To facilitate removal of any link assembly, the car should be placed on a ramp or over a pit; alternatively the front of the car should be jacked up.

2. Remove the split pin and castellated nut from the ball pin end, and using the special tool (RH 8100), extract the ball pin from the eye of the lever. Remove the ball pin from the opposite lever eye in a similar manner.

3. Remove the plug retaining the ball pin and collect the seal washer; the spring, spring seat and steel ball can then be removed together with the ball pin.

4. The rubber seals between the socket and lever eye should always be renewed if the joints have been disturbed.

5. A press must be used to remove and fit the ball seat, which is squarely pressed in position against the socket shoulder. The pressure required to fit the seat should be between 800 lb. and 1250 lb. (402,8 kg. and 566,9 kg.). It is important not to damage the chamfered top edge of the seat during the pressing operation, otherwise the sealing feature of the seat will be destroyed.

6. When the seat has been pressed squarely into position the ball pin should be lightly lubricated with an approved grease and inserted, followed by the steel ball, spring seat and the spring. Fit the aluminium joint washer and the plug.

7. Repeat this procedure to install any other ball pins which require renewal.

8. Check that all seal faces are free from burrs, then fit the seal and spring, after applying Rocol T 265 grease to the seal faces. Ensure that the tapers of the ball pins are free from lubricant, then locate the ball pin tapers in position; torque tighten the castellated nuts to between 35 lb. ft. and 40 lb. ft. (4,84 kg.m. to 5,53 kg.m.) and fit the split pin.

Note The seals fitted to the inner ends of the cross-tubes are not secured to the cross steering tube track rod ends.

9. Using Wanner grease gun (RH 7202), lubricate

the ball joints with the approved grease (see Chapter D), until it exudes from the seals.

10. Each joint will require approximately $\frac{3}{4}$ oz. (9,5 gm.) of lubricant for the initial filling operation, but this quantity will be reduced for periodic servicing.

Note It will be noted that the steering cross-beam ends have a 20° 'set' and if the cross-beam is removed, care must be taken to replace it in the correct position i.e. with the 'set' pointing towards the rear of the car (see Fig. N38). Care must be taken when fitting the track rods to ensure that the adjustable end is placed outwards towards the wheels.

11. Both of the adjustable ends of the track rods are right-hand threaded for adjustment of the toe-in. Toe-in must always be checked whenever any replacement parts have been fitted to the track rods.

Steering idler/damper—To remove

The steering idler/damper can be removed from the car without disturbing the rest of the steering linkage.

1. Place the car on a ramp.
2. Disconnect the battery.
3. Remove the front exhaust pipe assembly.
4. Support the engine with either a sling or a jack and wooden pad.
5. Remove the two nuts and washers securing the engine front mounting.
6. Remove the nuts and bolts securing the steering box pipes to the front engine cross-member.
7. Remove the split pin and nut from the idler/damper lever joint on the steering cross-beam then, using extractor (RH 8100) partially extract the ball pin from the lever.
8. Remove the four bolts, nuts and washers securing the engine cross-member to the steering box and the steering idler/damper housing; remove the cross-member.
9. Remove the three setscrews and washers securing the steering idler/damper box to the sub-frame.

Steering idler/damper—To dismantle
(see Fig. N39)

1. Clean the housing to remove all traces of dirt.
2. Remove the filler plug and the plug from either end of the cylinder bore; drain the fluid.
3. Unscrew and remove the washers and nuts securing the cover of the lever access hole then remove the cover together with the joint. Discard the joint.

Chapter N

4. Slacken the actuating lever pinch bolt.
5. Unscrew the four 2 B.A. nuts and remove the washers securing the top cover; remove the cover together with the joint. Discard the joint.
6. Remove the split pin, nut and washer from the top of the idler/damper shaft.
7. Remove the upper bearing cage and rollers from the housing.
8. Carefully remove the idler/damper shaft and lever from the housing and collect the chamfered adjusting washer from the top of the shaft.
9. Remove the fluid seal from the base of the housing and discard it.

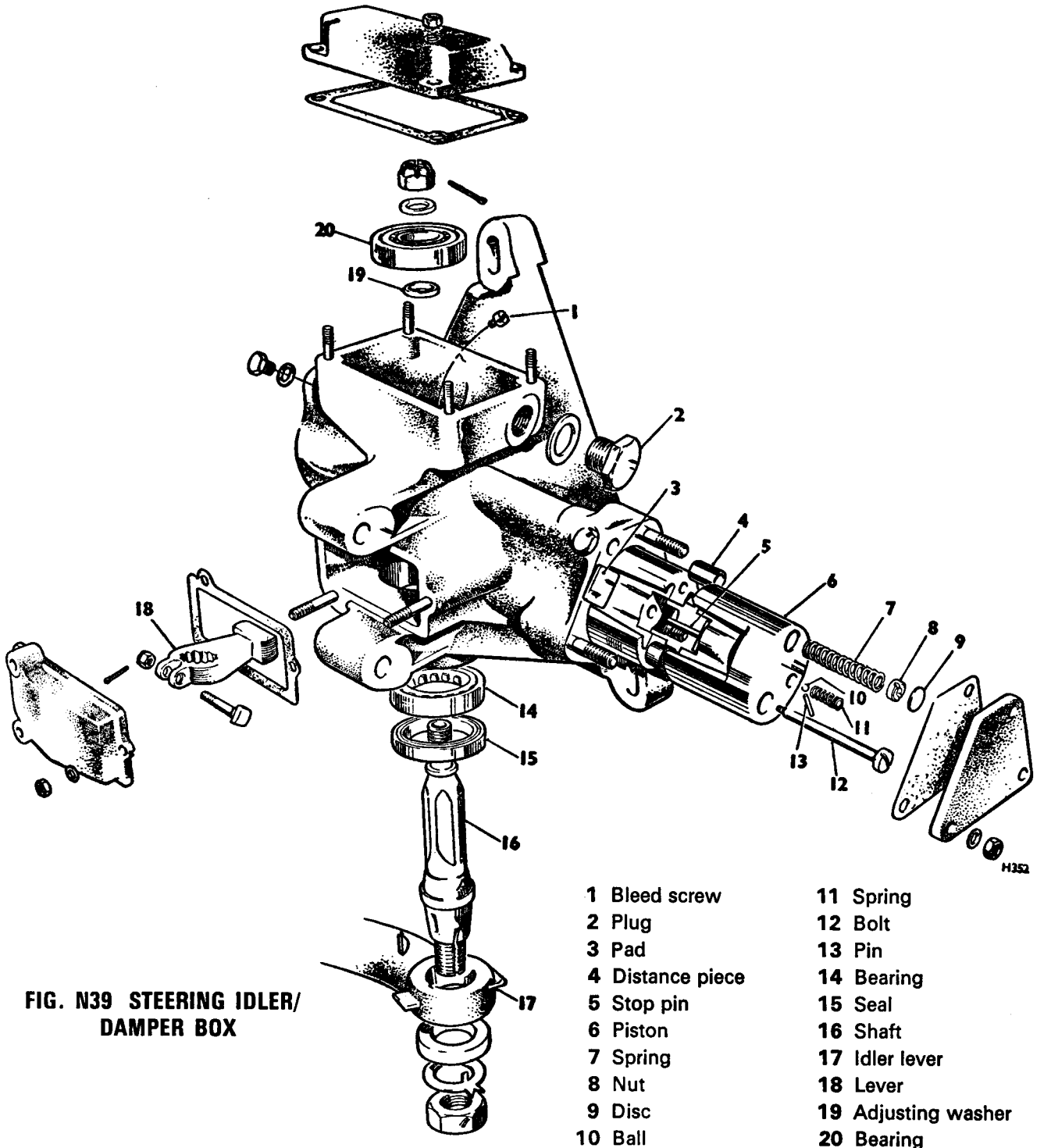

FIG. N39 STEERING IDLER/
DAMPER BOX

Printed in England/TVP LTD.

September 1968

T.S.D. 2476

Chapter N

10. Remove the lower bearing cage and rollers from the housing.
11. Remove the operating lever.
12. Unscrew the nuts and remove the washers securing the end cover and remove the cover together with the joint. Discard the joint.
Remove the piston assembly from the housing.

Bearings, actuating lever, piston shaft— To inspect

1. Wash all components thoroughly in paraffin prior to inspection.
2. Inspect the bearings, shaft, operating lever and piston assembly for signs of excessive wear, scoring or pitting, and renew if necessary.
Note If it is necessary to renew any part of the damper piston, parts may be obtained to build either a piston half or a complete piston.

Steering idler/damper—To assemble

1. Thoroughly clean all parts to be assembled.
2. If it is necessary to renew the bearings, the bearing outer tracks must be pressed from the housing and the new ones pressed squarely into position up to their abutment faces.
3. The interference between the housing and the bearing outer tracks should be 0.002 in. (0.051 mm.) and the diameter of the upper surface of the idler/damper shaft should be 0.500 in. (12.7 mm.) minus 0.005 in. (0.13 mm.).
4. Fit the Woodruff key, the idler/damper lever, lock washer and nut to the idler/damper shaft.
5. Torque tighten the nut to between 80 lb. ft. and 90 lb. ft. (11.06 kg.m. and 12.44 kg.m.) and bend over the lock washer.
6. Fit the two bearing outer races into the idler/damper housing and lightly coat with steering box fluid.
7. Place the lower thrust bearing on to the idler/damper shaft.
8. Fit the shaft through the idler/damper box.
9. Fit the thrust washer with the chamfer facing the lower thrust bearing.
10. Fit the upper bearing followed by the plain steel washer and castellated nut.

11. The pre-load on the bearings is to be adjusted by altering the thickness of the pre-load washer so that $\frac{1}{2}$ lb. to 1 lb. (0.227 kg. to 0.454 kg.) pull exerted at right angles to the idler/damper lever is required to rotate the shaft. Hold the assembly with the idler/damper shaft vertical while making this check.
12. If adjustment is required to alter the pre-load then it will be necessary to grind the flat surface of the pre-load washer.
13. Having found the adjustment, remove the idler/damper shaft and bearing cages and rollers, but do not mislay the adjusting washer.
14. Fit the lower bearing cage and rollers into the housing and then fit the shaft oil seal into the housing.

Piston—To assemble

1. Fit the ball followed by the spring on to its seat in the piston head.
Note The spring is fitted with the small coil pressing on the ball.
2. Depress the coil spring and insert the taper pin into the piston wall. The pin should be pressed in until the pin head is below the piston wall surface.
3. Carefully peen over the pin hole.
4. Repeat the above operation for the other piston half.
5. Fit the piston pads with their maximum width between the piston skirt extensions.
6. To assemble the two piston halves hold the piston so that looking at the piston crown the valve port is at the top.
7. Insert a bolt in the right-hand bore.
8. Repeat this operation for the other piston half.
9. Insert the operating lever stop pin into the outer hole of one of the piston halves.
10. Place a distance piece over each bolt and join the piston halves together.
11. Fit a spring and nut on each bolt.
12. Tighten the nut and fit a welch washer into the bore groove.
13. Punch the centre of the welch washer to flatten it and locate it in its groove.
14. Polish the piston with fine emery strip to remove any burrs.
15. Fit the piston with the actuator stop pin at the back opposite the lever cover aperture.
16. Fit the air bleed screw and two blanking plugs and aluminium washers.
17. Smear the shaft oil seal with grease (Retinax A).

Chapter N

18. Fit the pinch bolt and nut on to the actuator lever and fit the actuator lever in position between the piston with the offset to the top of the damper.

19. Insert the idler/damper shaft and lever assembly with the lower bearing in position and pass it through the square in the actuator shaft. Do not damage the seal while inserting the shaft.

20. The idler/damper shaft should be fitted so that the Woodruff key is lined up with the split in the actuator lever.

21. Fit the pre-loading washer, upper bearing, washer and nut, and torque tighten to between 42 lb. ft. and 45 lb. ft. (5,80 kg.m. and 6,22 kg.m.). Tighten to the next nearest split pin hole and fit the split pin.

22. Torque tighten the pinch bolt on the actuator lever to between 35 lb. ft. and 38 lb. ft. (4,84 kg.m. and 5,25 kg.m.).

23. Fit the actuator lever access hole cover.

24. Fit the piston bore end cover.

25. Mount the assembly in its normal operating position and fill it with the approved power steering fluid to the level of the bottom of the filler plug. Work the idler/damper lever slowly backwards and forwards over its full stroke and keep the level of fluid topped-up while doing so. Work the lever to and fro until the fluid level ceases to drop and until there is no free movement around the central position.

26. Fit the filler plug and fit the top cover and joint.

Steering idler/damper—To fit

1. Installation of the idler/damper is the reverse procedure given for its removal.

Note After fitting the steering idler/damper to the sub-frame it is important that the steering geometry is reset as detailed in Chapter H.

Toe-in—To set

To adjust the toe-in refer to 'Chapter H—Suspension Settings'.

Aligning the steering box 'tight spot' to road wheel straight ahead position

1. Place each front wheel on a turntable.
2. Disconnect the pendulum lever ball joint from the cross-beam using the special tool (RH 8100).
3. Turn the steering wheel to either full lock position.
4. Turn the steering wheel slowly towards the opposite lock whilst the second operator attempts to 'rattle' the pendulum lever.
5. Note the position of the steering wheel when the free play in the pendulum lever disappears.
6. Turn the steering to the other full lock position and repeat the above operation.
7. To find the steering box 'tight spot', position the steering wheel mid-way between the two positions previously recorded.
8. Note the steering wheel position and connect the pendulum lever ball joint to the cross-beam.
9. Position the steering wheel in the 'tight spot' position and alter the track rods by equal lengths until the road wheels are in the 'straight ahead' position.
10. Align the steering wheel spokes to the road wheels 'straight ahead' position.
11. To check the steering geometry (toe-in, lock stop adjustment and castor/camber angles) refer to 'Chapter H—Suspension settings'.

Chapter N

Section N7

FAULT DIAGNOSIS

| SYMPTOM | POSSIBLE CAUSE | ACTION |
|--|---|--|
| <p>Noisy steering system</p> <p>1. Steering pump (Hobourn Eaton)</p> <p>Steering pump (Saginaw) As in 1(a), (b), (c) and (d) above, plus the following:</p> | <p>1. (a) Low fluid level</p> <p>(b) Loose drive belt(s)</p> <p>(c) Pressure hose not correctly fitted</p> <p>(d) Excessive back pressure due to partially blocked pipes or resistance to steering gear movement</p> <p>(e) Scored rotor or rollers</p> <p>(f) Excessive wear on cam ring</p> <p>(g) Defective flow control valve</p> <p>(h) Scored pressure plate</p> <p>(j) Vanes incorrectly fitted</p> <p>(k) Vanes sticking in rotor slots</p> <p>(l) Extreme wear on pump ring</p> <p>(m) Face of thrust plate scored</p> <p>(n) Scored rotor</p> | <p>1. (a) Fill reservoir to correct level with an approved fluid and bleed system by operating steering</p> <p>(b) Correctly adjust drive belt(s)</p> <p>(c) Ensure correct run of hose</p> <p>(d) Locate restriction and correct if necessary</p> <p>(e) Renew rotor and rollers or fit new pump if required</p> <p>(f) Fit new steering pump</p> <p>(g) Renew valve</p> <p>(h) Lap to remove light scoring. Renew heavily scored components</p> <p>(j) Fit vanes correctly</p> <p>(k) Free by removing burrs or dirt</p> <p>(l) Renew pump ring, rotor and vanes</p> <p>(m) Lap to remove light scoring. Renew rotor, vanes and pump ring if rotor is heavily scored.</p> <p>(n) Lap to remove light scoring. Renew heavily scored components.</p> |
| 2. Steering box | 2. (a) Incorrect straight ahead adjustment | 2. (a) Correctly adjust tight spot in straight ahead position Note A slight rattle may occur in 'off-centre' positions because of increased clearance of the 'tight spot'. This is normal and straight ahead clearance must not be reduced below the specified limits in an effort to eliminate the noise |
| 3. Steering linkage | 3. (a) Steering box loose on front sub-frame (b) Steering linkage loose (c) Spool valve flutter on releasing steering wheel after full lock turn | 3. (a) Check torque tightness of securing bolts (b) Examine linkage pivot points for wear. Renew worn parts if required (c) Ensure that fluid is correct to specification. Examine spool valve 'O' rings for correct size and general condition |

Chapter N

| SYMPTOM | POSSIBLE CAUSE | ACTION |
|---|--|--|
| <p>Excessive play in steering</p> <p>4. Excessive play in steering wheel</p> | <p>4. (a) Excessive play in steering linkage</p> <p>(b) Steering arm backlash in 'straight-ahead' position</p> <p>(c) Incorrect thrust bearing pre-load</p> <p>(d) Incorrect worm and ball pre-load</p> <p>(e) Steering box loose on front sub-frame</p> <p>(f) Front wheel bearings incorrectly adjusted or worn</p> <p>(g) Worn check valve in pressure connection</p> <p>(h) Steering damper faulty</p> | <p>4. (a) Adjust steering linkage or renew parts if required</p> <p>(b) Correctly adjust rocking shaft gear backlash</p> <p>(c) Correctly adjust thrust bearing pre-load</p> <p>(d) Correctly adjust pre-load between worm shaft and re-circulating balls</p> <p>(e) Examine steering box mountings. Check torque tightness of securing bolts</p> <p>(f) Correctly adjust bearings or renew if required</p> <p>(g) Renew check valve</p> <p>(h) Renew damper</p> |
| <p>Oil leaks</p> <p>5. Oil leaks from steering box linkage</p> | <p>5. (a) Top cover 'O' ring seal leaking</p> <p>(b) Rocking shaft seals leaking</p> <p>(c) Housing end plug seals leaking</p> <p>(d) Rocking shaft backlash adjuster seal leaking</p> <p>(e) Torsion bar seal leaking</p> | <p>5. (a) Renew seal</p> <p>(b) Renew seals. Examine shaft for damage or wear</p> <p>(c) Renew seals</p> <p>(d) Renew seal</p> <p>(e) Renew seal. Examine torsion bar for damage</p> |
| <p>6. Oil leaks from steering pump and reservoir (Hobourn Eaton)</p> | <p>6. (a) Reservoir cover seal or filler cap seal leaking due to fluid level being too high or air in fluid</p> <p>(b) Reservoir to pump 'O' rings leaking</p> <p>(c) Flow control valve plug 'O' rings leaking</p> <p>(d) Steering pump bearing seal leaking</p> <p>(e) Reservoir or filler cap seals damaged</p> | <p>6. (a) Check oil level and top-up if required. Bleed system to remove air by operating steering. Examine cap and cover for damage or distortion</p> <p>(b) Renew 'O' rings</p> <p>(c) Renew 'O' rings</p> <p>(d) Renew seal. Examine shaft for wear or damage</p> <p>(e) Renew seals</p> |
| <p>7. Hoses and connections leaking</p> | <p>7. (a) Loose hose connections or damaged 'O' rings</p> <p>(b) Damaged hose</p> | <p>7. (a) Tighten hose connections. If tightening fails to cure leak, examine ends of hoses for cracks or damage. Renew 'O' rings if necessary</p> <p>(b) Examine hose for fretting, fraying or deterioration. Renew hose if required. Ensure that correct hose run is obtained and that hose clips are correctly fitted.</p> |

Chapter N

| SYMPTOM | POSSIBLE CAUSE | ACTION |
|---|---|---|
| 8. Car pulls to one side or the other | 8. (a) Front end geometry misaligned (b) Pump drive belt(s) slipping (c) Flow control valve sticking | 8. (a) Check steering geometry (b) Correctly adjust steering pump belt(s) (c) Examine flow control valve. Renew valve if necessary |
| 9. Momentary increase in effort when turning wheel quickly to right or left | 9. (a) Low fluid level in reservoir (b) Pump drive belt(s) slipping (c) Heavy internal fluid leak | 9. (a) Check fluid level. Top-up if required. Examine system for leaks (b) Correctly adjust pump drive belt(s) (c) Check pump outlet pressure. If pressure is low renew combined flow control and relief valve. If pressure remains low, check system for internal leaks by dismantling steering box |
| 10. Heavy steering | 10. (a) Incorrect tyre pressures (b) Loose pump drive belt(s) (c) Low fluid level in reservoir (d) Lack of lubricant in steering joints (e) Insufficient fluid pressure (f) Faulty or obstructed flow control valve (g) Incorrect front wheel alignment (h) Excessive castor or toe-in (i) Incorrect camber angle (j) Rocking shaft gear too tightly meshed (k) Distorted flexible coupling or defective universal joint (l) Triangle levers misaligned (m) Front sub-frame distorted (n) Kinks in hoses (o) Obstruction in hose. Inner bore of hose swollen, caused by overheated or incorrect fluid (p) Pressure loss in steering box cylinder caused by worn ring or scored bore (q) Leakage at valve rings or valve body to worm seal | 10. (a) Check and correct tyre pressures (b) Correctly adjust drive belt(s) (c) Check level of fluid in reservoir. Top-up if required. Examine system for leaks. (d) Examine all steering joints. Grease with approved lubricant if required (e) If the preceding checks do not reveal the cause of heavy steering check pump pressure (f) Renew or replace if necessary (g) Check and adjust if required (h) Adjust castor or toe-in to within specified limits (i) Correct camber angle to within specified limits (j) Disconnect track rods at steering arm. Check steering for stiffness. Adjust gear mesh if required (k) Examine flexible coupling. Renew if necessary. Examine universal joint in lower steering column. Renew if necessary (l) Check wheel castor and camber (m) Check sub-frame for correct alignment. Correct or renew if required (n) Ensure correct run of hoses (o) Renew hose (p) Overhaul steering box (q) Overhaul steering box |

Chapter N

| SYMPTOM | POSSIBLE CAUSE | ACTION |
|--|---|--|
| Heavy steering— <i>continued</i> | (r) Spool loose in valve body or leaking valve body (s) Damaged check valve in pressure hose connection (t) Flow control valve stuck or inoperative (u) Column bearings incorrectly adjusted | (r) Renew valve (s) Renew check valve (t) Examine flow control valve. Renew valve if necessary (u) Disconnect upper column from lower column. Correctly adjust column bearings. Grease bearings with approved lubricant |
| 11. Steering wheel side play | 11. (a) As in 10 (u) | 11. (a) As in 10 (u) |
| 12. Horn inoperative | 12. (a) Sticking brush or dirty slip ring on steering column | 12. (a) Examine brush and spring for freedom of movement |
| 13. Horn blows continuously | 13. (a) Short in horn button switch assembly in steering wheel centre | 13. (a) Examine horn button. Examine wires and connections. Check travel of horn button |
| 14. Steering column noisy in operation | 14. (a) Dry thrust bearings (b) Dry horn contact | 14. (a) Lubricate bearings (b) Lubricate horn contact |

Notes on steering system noise

It is improbable that the hydraulic side of the power assisted steering system will be absolutely quiet under all conditions and steering wheel positions. A slight hissing sound may be audible when the car is at parking speeds and attitudes, also when turning the steering wheel with a front road wheel against the kerb.

For fault diagnosis, Saginaw steering pump and hoses, refer also to Section N4.

Section N8

WORKSHOP TOOLS

| Tool Number | Description |
|------------------|---|
| RH 7202 | 'Wanner' Grease Gun—Steering Linkage |
| RH 7674 | Pliers—Two-way—Circlip and Snap Ring—Steering Column and wheel |
| RH 7779 (J-6219) | Fitting Tool—Rocking Shaft Seal—Steering Box |
| RH 7780 (J-5188) | Fitting Tool—Adjuster Plug Seal—Steering Box |
| RH 7781 (J-6657) | Extraction and Fitting Tool—Rocking Shaft Bearing—Steering Box |
| RH 7782 (J-6222) | Seal Protector—Adjuster Plug Assembly—Steering Box |
| RH 7783 (J-6221) | Extraction and Fitting Tool—Adjuster Plug Needle Bearing—Steering Box |
| RH 7785 (J-7576) | Piston Seal Compressor—Steering Box |
| RH 7786 (J-6217) | Fitting Tool—Valve Connector Seat—Steering Box |
| RH 7787 (J-7539) | Piston Arbor—Steering Box |
| RH 7788 (J-7624) | Spanner—Steering Box |
| RH 7870 | Extractor—Steering Wheel |
| RH 7871 | Flat Pin Spanner—Steering Column (For use on non-collapsible columns only) |
| RH 7872 | 'C' Spanner—Steering Wheel and Column (For use on non-collapsible columns only) |
| RH 8023 | Extractor—Pendulum Lever—Steering Linkage |
| RH 8080 | Extractor—Ball Pin—Track Rods—Steering Linkage |
| RH 8100 | Extractor—Ball Pin—Cross-beam—Steering Linkage |