

Chapter U

Section U10

SUPPLEMENTS

No. 6 North America 1976

Rolls Royce motor cars conforming to the appropriate emission control regulations and produced to the 1976 specification can be readily identified as follows.

1. Car Serial Number

A letter E as the last prefix of the Car Serial Number (e.g. SRE or LRE, etc.).

2. Emission Control Certification Label

A 1976 Emission Control Certification Label (illustrated below) fitted to the wing valance to the rear of the right-hand front suspension spring cover.

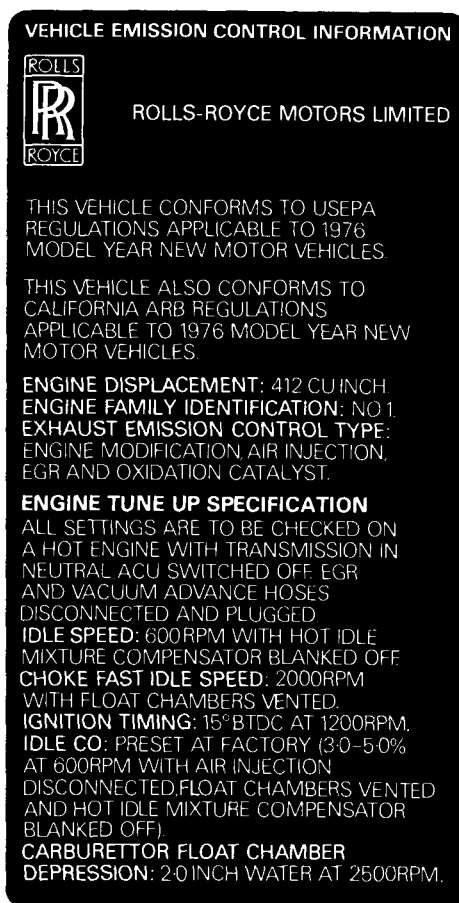

R 57

1976 EMISSION CONTROL CERTIFICATION LABEL

Chapter U

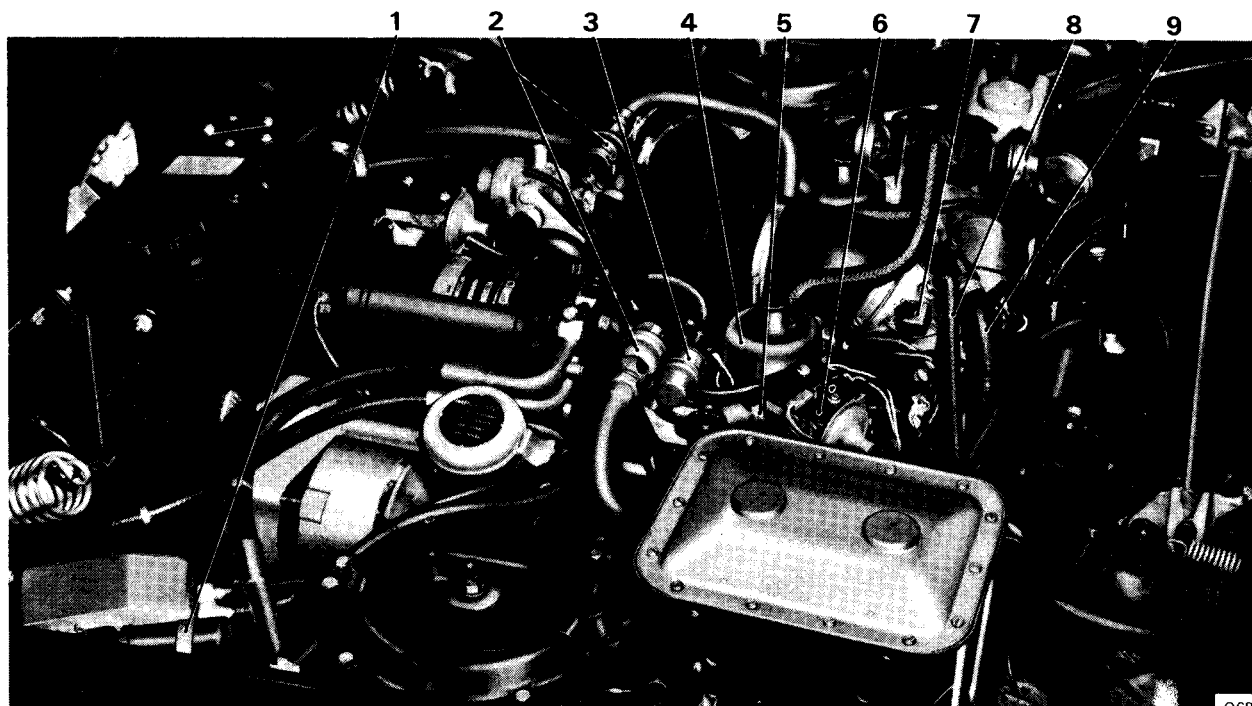

Q68

FIG. 1 VIEW INSIDE ENGINE COMPARTMENT (From Left-hand side of Car)

- | | |
|---------------------------|---|
| 1 Weaker filter | 6 E.G.R. secondary valve cut-in micro-switch assembly |
| 2 Check valves | 7 Choke solenoid |
| 3 Anti 'run-on' solenoid | 8 Choke stove pipe |
| 4 'B' bank carburetter | 9 Crankcase emission control system breather tube |
| 5 E.G.R. cut-out solenoid | |

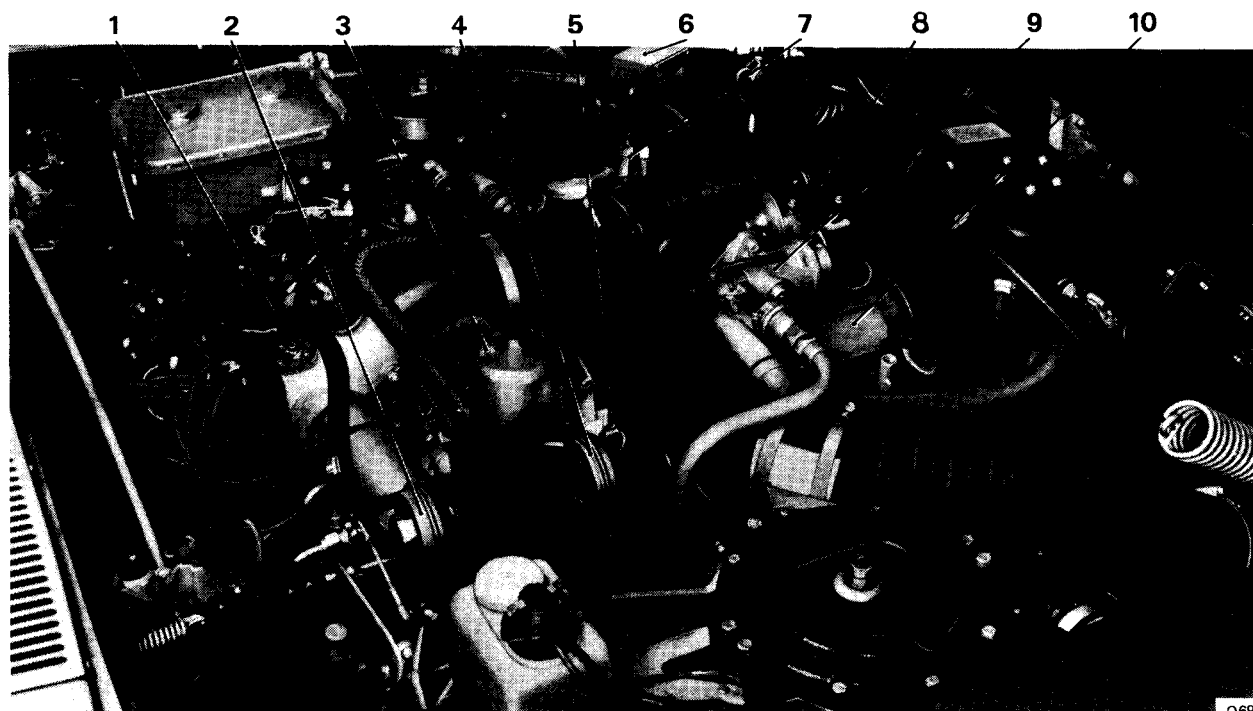

Q69

FIG. 2 VIEW INSIDE ENGINE COMPARTMENT (From Right-hand side of Car)

- | | |
|---|--|
| 1 Weaker system cut-off switch | 6 Speed control system regulator |
| 2 E.G.R. primary valve | 7 Hydraulic accumulator fluid pressure switches |
| 3 'A' bank carburetter | 8 Air diverter valve cut-out micro-switch assembly |
| 4 E.G.R. secondary valve | 9 Air diverter valve |
| 5 E.G.R. full throttle cut-out micro-switch | 10 Air pump |

EXHAUST EMISSION CONTROL SYSTEM

AIR INJECTION SYSTEM

Air injection system relief valve

The relief valve located in the discharge cavity of the air pump is changed on 1976 model year cars and is as follows.

Air pump relief valve

A spring loaded relief valve is located within the diverter valve housing and permits excess air to bypass the air injection system when the check valves are closed. The by-pass system prevents damage to the pump vanes and excessive exhaust temperatures under extreme operating conditions.

Air diverter valve

The air diverter valve is located at the front of the engine above the air pump (*see Fig. 2*) and performs two important functions in addition to housing the pressure relief valve for the air pump.

(i) **Backfire protection** (*see Fig. 3*)

Following rapid throttle closure, the inlet manifold pressure drops suddenly, causing fuel to be vapourised from the manifold walls which results in a mixture too rich to burn in the cylinders. This mixture combined with the air injected into the exhaust ports could cause backfiring.

To prevent backfiring, the diverter valve, triggered by manifold depression diverts the injected air from the exhaust ports for a short period of time.

(ii) **Catalyst overtemperature protection** (*see Fig. 3*)

Under high load conditions the low manifold depression activates a vacuum switch controlling a solenoid valve. The solenoid valve is located in the pressure line connecting the diverter valve inlet to the lower diaphragm cover. When the vacuum switch is activated the solenoid opens and applies air pump delivery pressure to the lower diaphragm, thereby diverting the air from the exhaust ports. This prevents excessive temperatures which could result in catalyst failure.

Air diverter valve—To check

The air diverter valve is a non-serviceable component. If the operation of the component is suspect, the following checks should be carried out before it is replaced.

1. Ensure that the parking brake is firmly applied and the vehicle is in 'Park'.
2. Start and run the engine at 2 000 r.p.m.
3. Ensure that **air does not escape** from the air diverter valve exhaust ports situated around the body of the air diverter valve (*see Fig. 3*).

If air does escape from the air diverter valve during Operation 3 check the following.

- (a) Check the setting of the **air diverter valve vacuum operated micro-switch assembly**, refer to Page U175 of this Supplement.
- (b) Check the operation of the **air diverter valve cut-out solenoid**, refer to Page U176 of this Supplement.
- (c) Check the **hose** (*see Fig. 5*) from the air diverter valve cover to the solenoid in the air diverter valve vacuum operated micro-switch assembly, rectify any air leaks.

Chapter U

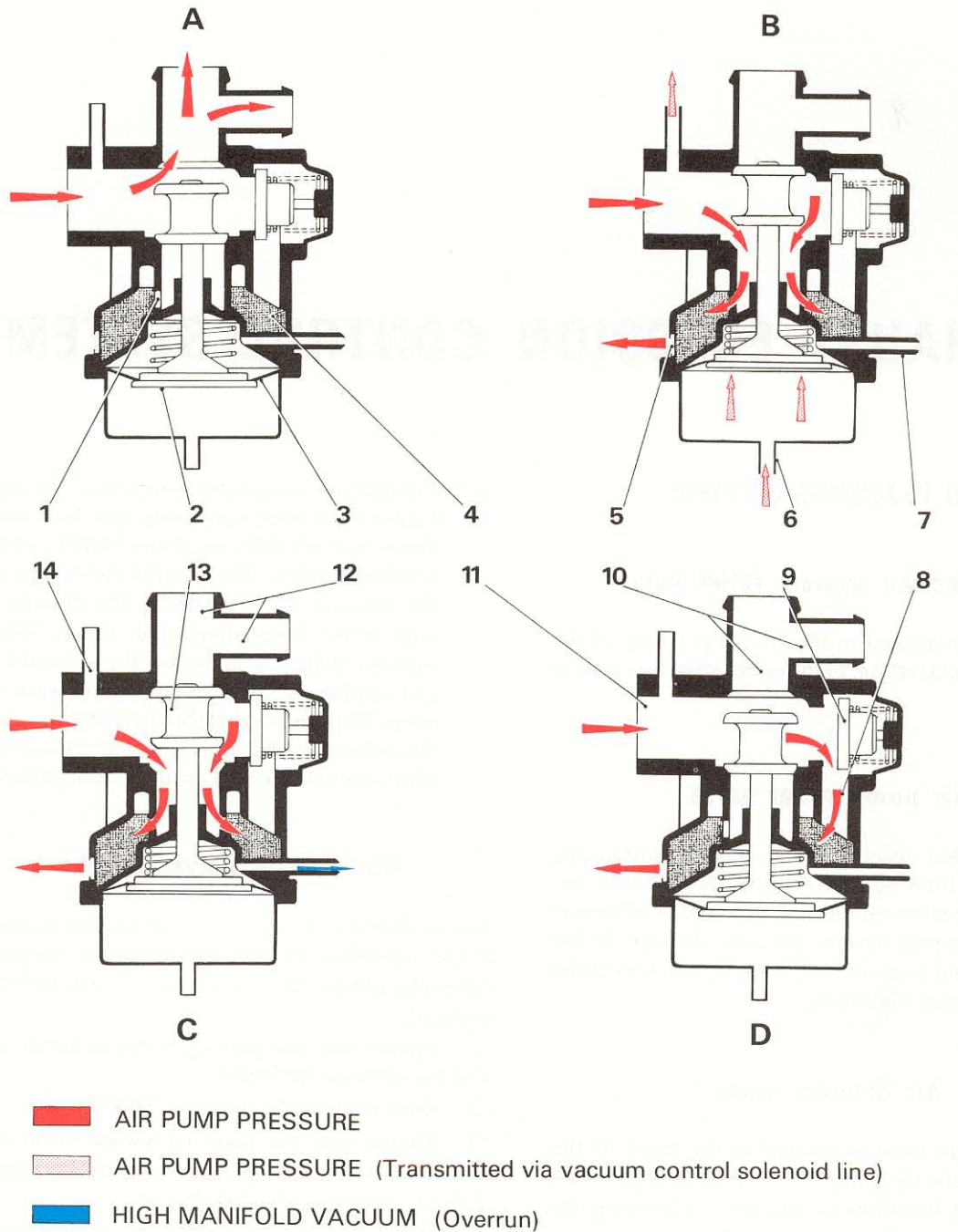

Q 308

FIG. 3 AIR DIVERTER VALVE

- A Normal operation
- B Catalyst over temperature protection
- C Backfire protection
- D Relief valve operation

- 1 Exhaust to internal silencer
- 2 Timing valve
- 3 Lower diaphragm
- 4 Internal silencer

- 5 Exhaust to atmosphere
- 6 Air pump pressure via solenoid valve
- 7 Manifold vacuum signal
- 8 Excess air
- 9 Relief valve
- 10 Valve outlets restricted
- 11 Valve inlet
- 12 Valve outlets to air manifolds
- 13 Metering valve
- 14 Air pump pressure to solenoid valve

Chapter U

(d) Repeat Operations 1 to 3 inclusive.

If air still escapes from the exhaust ports the air diverter valve assembly is faulty due to either a failed relief valve or a seized shuttle and must be replaced.

After fitting a new air diverter valve, ensure that the component operates satisfactorily.

4. Release the throttle linkage sharply so that the engine speed rapidly falls from 2 000 r.p.m., ensure that **air does escape** from the air diverter valve exhaust ports for a short period of time.

If air does not escape from the exhaust ports of the air diverter valve during Operation 4 check the following.

- The condition of the hose (see Fig. 5) from the air diverter valve to the vacuum manifold.
- The condition of any hose connected to the vacuum manifold (see Fig. 5).
- Repeat Operation 4.

If air still does not escape during Operation 4 the air diverter valve assembly is faulty due to either a diaphragm or timing valve failure and must be replaced.

After fitting a new air diverter valve, ensure that the component operates satisfactorily.

5. Allow the engine to idle at 600 r.p.m. Ensure that **no air escapes** from the air diverter valve exhaust ports.

Air diverter valve—To remove

Before commencing to remove the air diverter valve observe the following points.

- When disconnecting the various hoses ensure that each is suitably labelled to assist identification when assembling.
- Ensure that all open ends of pipes and hoses are suitably blanked off to prevent the ingress of dirt, etc.

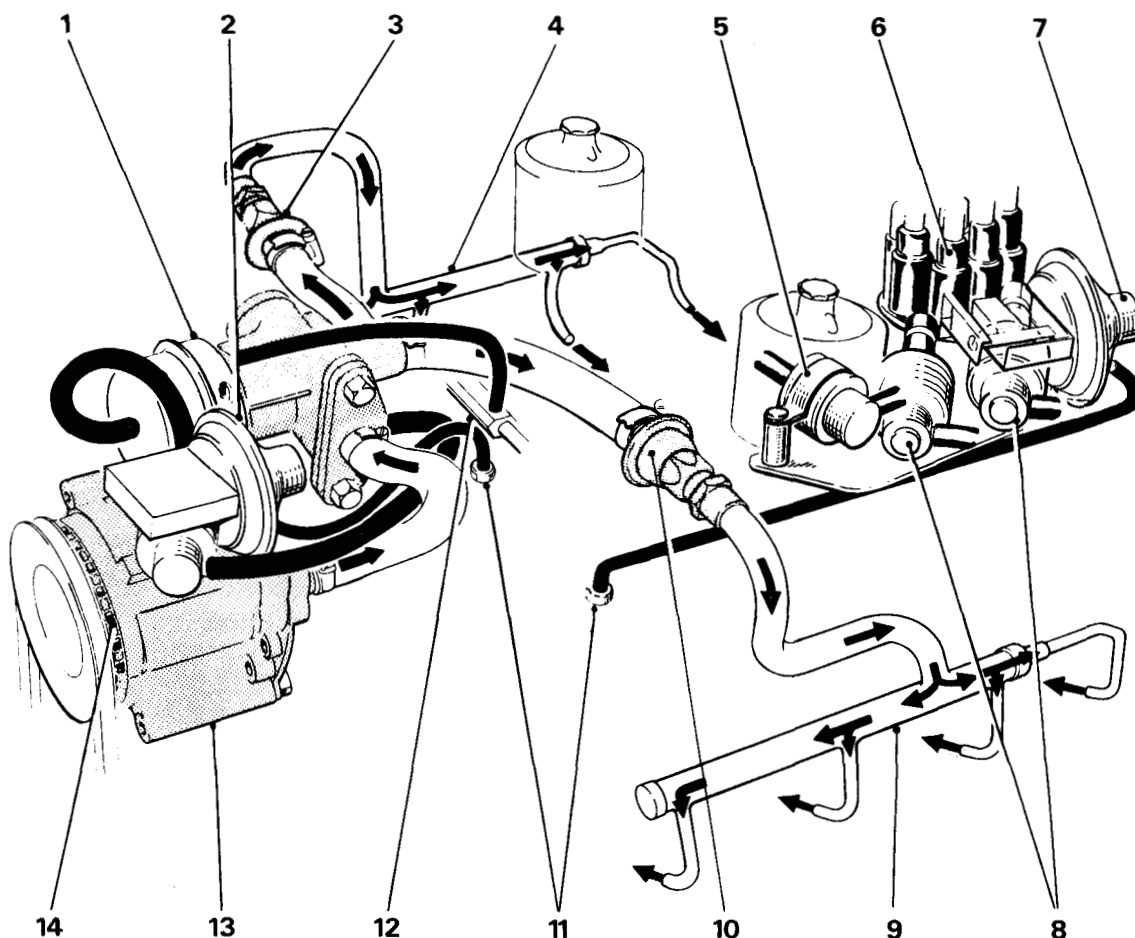

FIG. 4 AIR INJECTION SYSTEM

- | | | |
|--|---|----------------------------|
| 1 Air diverter valve | 5 Anti 'run-on' solenoid | 9 'B' bank air manifold |
| 2 Air diverter valve vacuum operated micro-switch assembly | 6 Ignition distributor | 10 Check valve |
| 3 Check valve | 7 Secondary valve micro-switch assembly | 11 Inlet manifold tappings |
| 4 'A' bank air manifold | 8 Exhaust gas recirculation solenoids | 12 Vacuum manifold |
| | | 13 Air pump |
| | | 14 Air pump intake |

Q 389

Chapter U

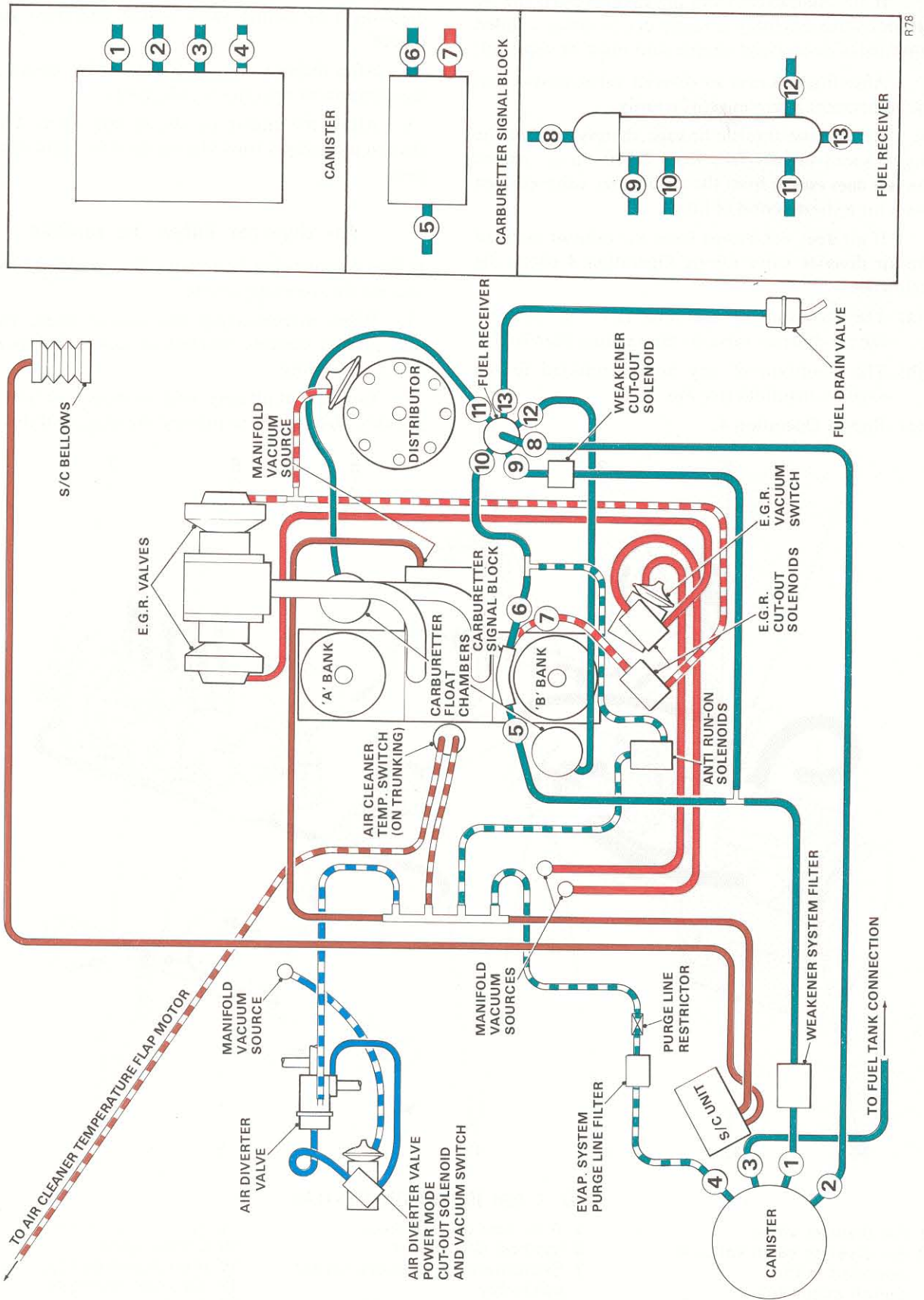

FIG. 5 HOSE ROUTING DIAGRAM—1976 MODELS

To remove the air diverter valve proceed as follows

1. Unscrew the three worm drive clips which secure the three larger diameter rubber hoses to the air diverter valve and withdraw the hoses. Two of the hoses connect to their respective air manifold check valves and the third hose to the air pump.

2. Withdraw the three smaller diameter rubber hoses from the air diverter valve.

The hose fitted to the front of the air diverter valve connects to the solenoid of the air diverter valve vacuum operated micro-switch assembly. The hose fitted to the rear of the assembly connects to the solenoid inlet and the hose fitted on the top of the assembly connects to the vacuum manifold. The hose connections are illustrated in Figure 4.

3. Using a $\frac{7}{16}$ in. A/F spanner unscrew and remove the two nuts which secure the air diverter valve to the mounting plate. Collect the two washers.

4. Hold the air diverter valve and withdraw the two bolts from the mounting plate, taking care not to lose the washer situated under the head of each bolt.

5. Remove the air diverter valve together with the spacer plate and gasket.

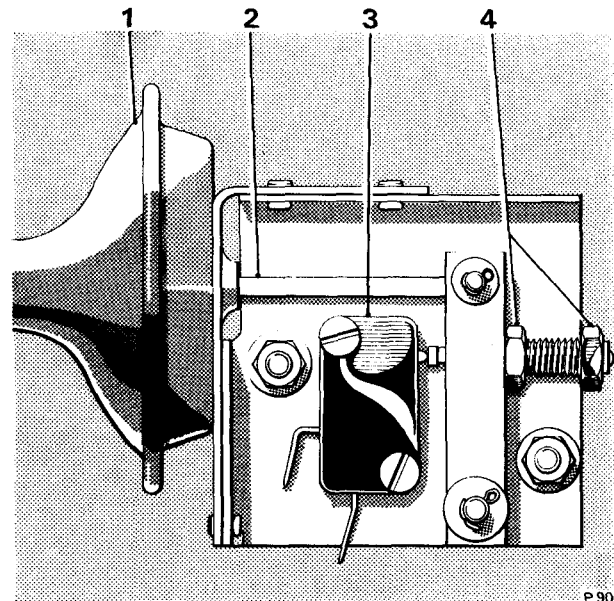

FIG. 6 VACUUM OPERATED CUT-IN SWITCH

- 1 Vacuum unit
- 2 Actuating link
- 3 Micro-switch
- 4 Adjustment screws

Air diverter valve—To fit

Fit the air diverter valve by reversing the procedure given for removal, noting the following points.

1. Ensure that all joint faces are clean.
2. Ensure that the gasket is in a good condition.
3. Always ensure that the spacer plate is fitted with the spigot projecting through the mounting plate into the hose which connects to the air pump and that the gasket is fitted to the opposite side of the mounting plate from the spigot.

EXHAUST GAS RECIRCULATION SYSTEM

A proportion of the exhaust gas from the 'A' bank exhaust downtake pipe is recirculated through vacuum operated metering valves into the carburettor 'Tee' piece, just downstream of the throttle plates. This exhaust gas mixes with the inlet charge in the induction manifold and is distributed to the cylinders thus lowering the peak combustion temperature and reducing the formation of oxides of nitrogen emissions.

A 'dual valve' exhaust gas recirculation system is used, employing a **primary valve** with a tapered metering pintle which gives an increase in flow area for an increased valve lift, and a **secondary valve** which has a reverse tapered pintle and gives a minimum flow area at full valve lift.

The vacuum signal for the **primary exhaust gas recirculation valve** is taken from a series of drillings in the carburettor body, just upstream of the throttle edge. As the throttle is opened the signal strength is progressively increased.

The **secondary valve** vacuum signal is taken from the induction manifold via a **solenoid valve** which is controlled by a vacuum switch; the secondary valve only receives the vacuum signal when a predetermined manifold depression is reached.

When the throttle is opened the **primary valve** opens progressively as the vacuum signal increases. The valve is fully open at the point where the vacuum signal equals manifold depression.

Continued opening of the throttle lowers the manifold depression and actuates the **secondary valve** which immediately moves to the full valve lift position. Further opening of the throttle continues to reduce the manifold depression and consequently, the signal to both exhaust gas recirculation valves.

The reduced signal and valve lift reduces the flow area through the **primary valve** and increases the flow area through the **secondary valve**.

At very low vacuum signal strength both valves are seated and the flow is zero; in this way the recirculated exhaust gas is metered in proportion to the engine requirements for a reduction of oxides of nitrogen whilst retaining acceptable drivability.

Chapter U



R67

FIG. 7 EXHAUST GAS RECIRCULATION SYSTEM

- | | | |
|---|---|-------------------------------------|
| A Hoses to be detached when removing carburetters | 3 Feed for distributor capsule | 5 Secondary valve solenoid assembly |
| 1 Primary valve | 4 Secondary valve vacuum operated micro-switch assembly | 6 Fuel mixture weakening device |
| 2 Secondary valve | | 7 Primary valve solenoid assembly |
| | | 8 Inlet manifold vacuum tappings |

To improve starting and driveaway quality at low temperatures solenoid valves activated by lock-out switches (see Fig. 15), interrupt the vacuum signals to both exhaust gas recirculation valves, ensuring that they remain in the closed position, until predetermined coolant temperatures are reached. The **secondary valve** cuts in at a higher coolant temperature than the **primary valve**.

A micro-switch operated by the throttle lever (see Fig. 8) also controls the cut-off solenoids to provide exhaust gas recirculation cut-off at full throttle. This feature of the system prevents the secondary valve remaining open under full throttle, high speed operation, as this would be detrimental to performance and fuel consumption.

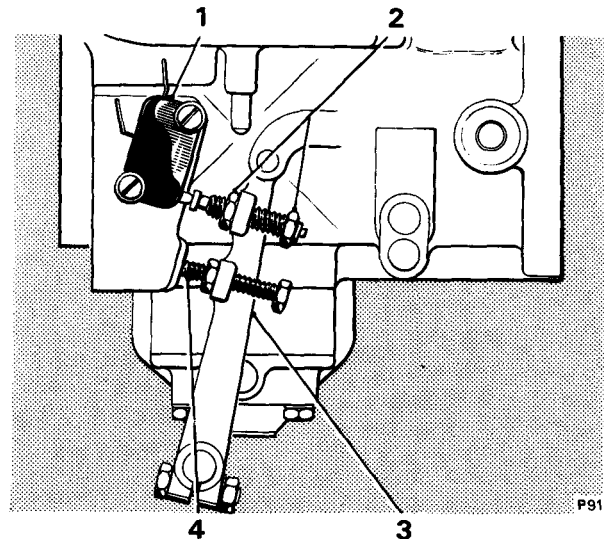

FIG. 8 FULL THROTTLE CUT-OFF MICRO-SWITCH

- 1 Micro-switch
- 2 Adjusting screws
- 3 Throttle lever
- 4 Full throttle stop

Exhaust gas recirculation valve—To remove

1. Detach the small diameter rubber hose from the valve.
2. Using a $\frac{1}{2}$ in. A/F spanner slacken the three nuts which retain the heat shield.
3. Withdraw the heat shield.
4. **Primary valve**—Unscrew and remove the two $\frac{1}{2}$ in. A/F nuts and washers retaining the valve to the mounting flange.

Secondary valve—Using a $\frac{1}{2}$ in. A/F spanner slacken the remaining nuts and then unscrew and remove both retaining nuts and washers. Unscrew the $\frac{7}{16}$ in. A/F nut retaining the mounting bracket to the 'A' bank carburettor bracket; collect the washer and withdraw the bolt.

5. Withdraw the valve and remove the gasket from the mounting flange face.

3. Clean the carbon from the valve using a wire brush fitted into a portable drill. Take care not to damage the valve seating area.

4. Thoroughly blow out the valve with compressed air to ensure that all loose carbon particles are removed.

5. Upon completion of the cleaning operations, fit the valve to the engine mounting flange as described in Exhaust gas recirculation valve—To fit.

Exhaust gas recirculation valve—To fit

Fit the valve by reversing the procedure given for removal, noting the following points.

1. Ensure that the valve pintle is secure on the valve stem.
2. Ensure that the valve and mounting flange joint faces are clean and free from carbon deposits.
3. Always use a new mounting flange gasket.

Exhaust gas recirculation valve—To clean

1. Remove the valve as described in Exhaust gas recirculation valve—To remove.
2. Using a scraper, remove all carbon film from the valve and mounting flange faces; complete the operation with a wire brush.

Exhaust gas recirculation valves—Preliminary check

To carry out preliminary checks on the operation of both **primary** and **secondary** exhaust gas recirculation valves proceed as follows.

1. Connect an electric impulse tachometer to the engine in accordance with the manufacturer's instructions.
2. Ensure that the parking brake is firmly applied and that the gear range selector is in the 'Park' position.
3. Start the engine and run until normal operating temperature is attained.
4. Allow the engine to return to the idle speed.
5. Increase the engine speed slowly noting the operation of the exhaust gas recirculation valves.

Chapter U

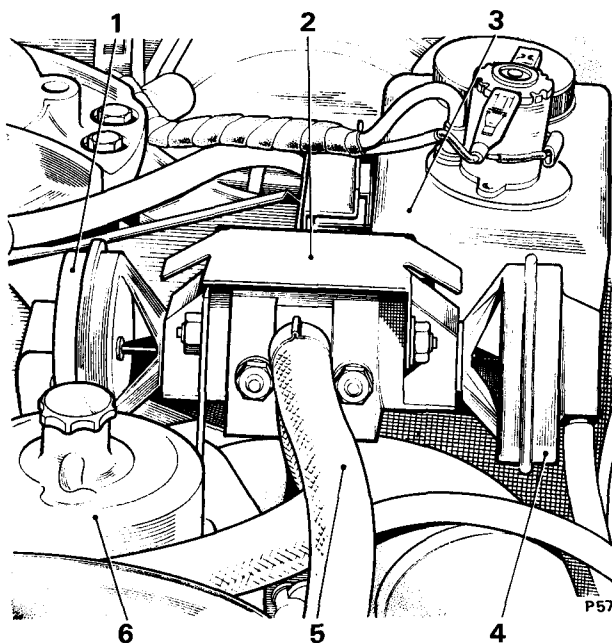

FIG. 9 EXHAUST GAS RECIRCULATION VALVES

- 1 Secondary valve
- 2 Heat shield
- 3 Windscreen washer reservoir
- 4 Primary valve
- 5 Distribution pipes
- 6 'A' bank carburetter

6. When the engine speed has reached 2 000 r.p.m. the diaphragm of the primary exhaust gas recirculation valve should have moved to the 'full valve lift' position.

7. Stop the engine. Disconnect the hose from the secondary valve cut-in solenoid vacuum unit. Blank off the open end of both the unit and the hose.

8. Disconnect the hose from the primary valve and blank off the open end of both the valve and the hose.

9. Start the engine and note that the secondary valve also moves to the full lift position. It may be necessary to increase the engine speed to prevent stalling.

If both diaphragms **have moved** to 'full valve lift' position in their respective tests, stop the engine and remove the tachometer as the test is complete.

Remove the blanks from the hoses; fit the vacuum unit hose and primary valve hose to their respective connections.

If the diaphragms **have not moved** to the required position stop the engine and proceed as follows.

Exhaust gas recirculation valve signal strength—To check

1. Remove the pressure tapping cap from 'A' bank carburetter to vent the float chambers.

2. Disconnect at the signal block the exhaust gas recirculation cut-out solenoid hose. Connect a mercury manometer 0 to 10 in. Hg. (0 to 25.4 cm. Hg.) to the signal line tube.

3. Fit dial gauge assemblies RH8841 to the carburetters in place of the dampers.

4. Zero the gauges with the engine stationary.

5. Lightly tighten the clamp screws of the dial gauge assemblies.

6. Start the engine and allow to run at an idle speed of 600 r.p.m., ensure that the piston lift of the carburetters shown on the dial gauge assemblies is equal (within 10%), adjust by using the eccentric adjuster on the carburetter throttle linkage.

7. Raise the engine speed using the idle speed adjusting screw until 'B' bank carburetter dial gauge reads 0.25 in. (6.35 mm.). 'A' bank carburetter dial gauge should also read 0.25 in. (6.35 mm.) with a tolerance of plus or minus 0.010 in. (0.254 mm.).

Note The suction chambers of both carburetters should be lightly tapped with a non-metallic object (wooden handle of a small screw-driver) during this operation.

8. Adjust the exhaust gas recirculation signal to 3.2 in. Hg. (8.13 cm. Hg.) using the adjusting screw (see Fig. 19, item 15).

9. If difficulty is experienced in obtaining the signal reading, ensure that air is not leaking at the signal block joint.

10. Disconnect the manometer and connect the exhaust gas recirculation solenoid hose to the signal tube.

Note If it is necessary to adjust the E.G.R. signal by more than 0.2 in. Hg. (0.51 cm. Hg.), refer to Operation 8, Page U187—Float chamber depression—To check and ensure that the maximum steady manometer reading is still obtainable within an engine speed range of 1 300 r.p.m. to 1 600 r.p.m.

Primary valve

11. Disconnect the solenoid to exhaust gas recirculation primary valve hose at the valve. Connect the hose to the manometer.

12. Repeat Operation 7.

13. Ensure that the exhaust gas recirculation signal shown on the manometer is between 3.0 in. Hg. (7.6 cm. Hg.) and 3.4 in. Hg. (8.6 cm. Hg.).

A **low** or **zero** reading may be caused by:

- a. Blockage in the hose from the signal tube to the cut-out solenoid.
 - b. Blockage in the hose between the cut-out solenoid and primary E.G.R. valve.
 - c. Air leak at the signal block joint face or hose connections.
 - d. Low engine temperature below 14°C. (57°F.), a faulty exhaust gas recirculation cut-off solenoid or lock-out switch (in thermostat outlet).
14. Disconnect the manometer and connect the hose to the exhaust gas recirculation valve.
 15. Check the operation of the valve by running the engine at 2 000 r.p.m. ensuring that the valve opens by observing the movement of the diaphragm.

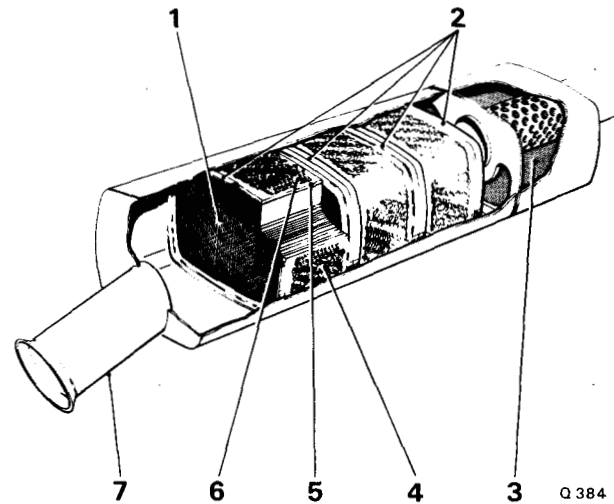

FIG. 10 CATALYTIC CONVERTER

- 1 Monolithic catalyst
- 2 Catalyst retaining plates
- 3 Silencing chamber
- 4 Stainless steel wire mesh
- 5 Fireclay coating
- 6 Ceramic tape
- 7 Inlet pipe

Secondary valve

11. Disconnect the rubber hose from the induction manifold to the vacuum operated micro-switch, at the micro-switch end and blank off the hose.
12. Detach the secondary valve to solenoid hose at the secondary valve.
13. Connect a suitable mercury manometer 0 to 10 in. Hg. (0 to 25.4 cm. Hg.) to the hose.
14. Disconnect the hose from the inlet manifold tapping to the secondary valve solenoid at the solenoid. Blank off the hose.
15. Disconnect the hose from the low temperature exhaust gas recirculation solenoid to the primary valve, at the valve.
16. Connect the primary valve hose to the open connection on the secondary valve solenoid.
17. Repeat Operation 7.
18. Ensure that the exhaust gas recirculation signal shown on the manometer is between 3.0 in. Hg. (7.6 cm. Hg.) and 3.4 in. Hg. (8.6 cm. Hg.).

A **low** or **zero** reading may be caused by:

- a. A blockage in the hose from the secondary valve solenoid to the exhaust gas recirculation secondary valve.
 - b. A faulty exhaust gas recirculation secondary valve solenoid.
 - c. Low engine temperature below 44°C. (111°F.), or a faulty exhaust gas recirculation lock-out switch (in thermostat housing).
19. Disconnect the mercury manometer and connect the hoses to their respective connections, leaving only the hose to the vacuum operated micro-switch disconnected and blanked off.

20. Check the operation of the valve by running the engine and observing the movement of the diaphragm.

If the secondary valve does not move, it may be due to a blockage in the hose from the manifold to the secondary valve solenoid.

21. Connect the hose to the vacuum operated micro-switch after first removing the blank.

OXIDATION CATALYST SYSTEM

A catalytic converter, in place of the conventional front silencer is situated in the exhaust system to the rear of the point in the system where both exhaust manifold downtake pipes combine.

The box unit contains three catalyst blocks and has sufficient volume to perform the dual functions of both converter and silencer (see Fig. 10). A platinum group metal catalyst on a ceramic monolith support is used for optimum conversion efficiency and rapid warm-up. Three separate blocks are used to minimise the effect of thermal shock and are positioned to ensure good gas distribution and effective utilisation of the catalyst volume.

The catalyst promotes reaction between the residual hydrocarbons and carbon monoxide in the exhaust and the secondary air injected into the exhaust ports. After completion of the oxidation process the exhaust gas is discharged to the atmosphere from the tailpipe.

Chapter U

Catalytic converter protection

To protect the catalytic converter from possible damage the following precautions should be taken.

(i) **Unleaded gasoline**

Use unleaded gasoline only. The use of leaded gasoline will result in a **substantial reduction in the performance of the catalyst**. Under no circumstances add fuel system cleaning agents to either the fuel tank or carburettors for induction into the engine, as these materials may have a **detrimental effect on the catalytic converter**.

(ii) **Engine malfunction**

If the engine misfires or suffers from a lack of power which could be attributed to a malfunction of either the ignition or fuel systems, the vehicle **should be driven only at low speed** and the fault rectified as soon as possible by an authorised Dealer. Driving at high speeds with a malfunction in either of these systems could cause overheating and consequent damage to the catalyst.

(iii) **Fuel**

Do not allow the engine to run out of fuel. If the engine does run out of fuel at a high speed possible **damage to the catalyst could result**.

Catalytic converter—To remove

1. Unscrew the self-tapping screws that secure the shield below the catalytic converter assembly. Withdraw the shield.

2. Unscrew the $\frac{7}{16}$ in. A/F nuts that secure the two shields to the exhaust pipe on either side of spherical joint, situated to the rear of the body crossmember.

3. Collect the washers, withdraw the bolts and remove the shields.

Note Take care when removing the shields as the edges are sharp and could cause injury to the hands.

4. Support the weight of the exhaust pipe which passes into the expansion box.

5. Using a $\frac{1}{2}$ in. A/F spanner unscrew and remove the nut retaining the exhaust mounting around the exhaust pipe (situated behind the body crossmember).

6. Remove the nut and withdraw the bolt, collect the washer.

7. Open the mount and slide it over the exhaust pipe.

8. Slacken the two $\frac{9}{16}$ in. A/F nuts retaining the exhaust clamp around the spherical joint to the rear of the body cross-member and catalytic converter assembly.

9. Unscrew the nuts completely and withdraw the bolts; collect the washers.

10. Remove the two halves of the clamp joint from the exhaust pipe. Free the two sections of the pipe from each other and collect the sealing ring.

11. Allow the forward section of the exhaust to rest on the body cross-member and repeat Operations 8 to 10 inclusive on the spherical exhaust joint situated in front of the catalytic converter assembly. Hold the forward end of the assembly as the front joint is freed.

12. Withdraw the catalytic converter assembly in a forward and downwards direction.

Catalytic converter—To Fit

Fit the catalytic converter assembly by reversing the procedure given for removal, noting the following points.

1. The seal rings and pipe flares must be thoroughly clean and free from scale and may be lightly dressed with fine emery cloth if required.

2. The clamp bolt threads should be lightly oiled to prevent binding during assembly and the spherical faces of the sealing rings and the grooves in the clamps should be smeared with a graphite lubricant, to ensure correct alignment of the pieces on assembly.

3. Fit the pipe and catalytic converter assembly complete with seal rings, then loosely fit the joint clamps and the 'handcuff' clamp.

4. The joints must not be fully tightened until the pipe has been manoeuvred to obtain the best run (free from possible fouls) and good joint alignment.

Note The pipe joints must not be 'sprung' or 'clamped' into position.

5. When the pipe run is satisfactory, torque tighten the joint clamp nuts in accordance with the standard torque figures given in Chapter P then 'set' the 'Vibrashock' mount to allow for expansion in the exhaust system, when hot.

'Vibrashock' exhaust mount—To set

This exercise is carried out by holding the 'handcuff' clamp forward whilst tightening the pinch bolt. This has the effect of misaligning the centre of the mount and this misalignment should be approximately 0.187 in. (4.76 mm.) at the mount centre.

FUEL EVAPORATION EMISSION CONTROL SYSTEM

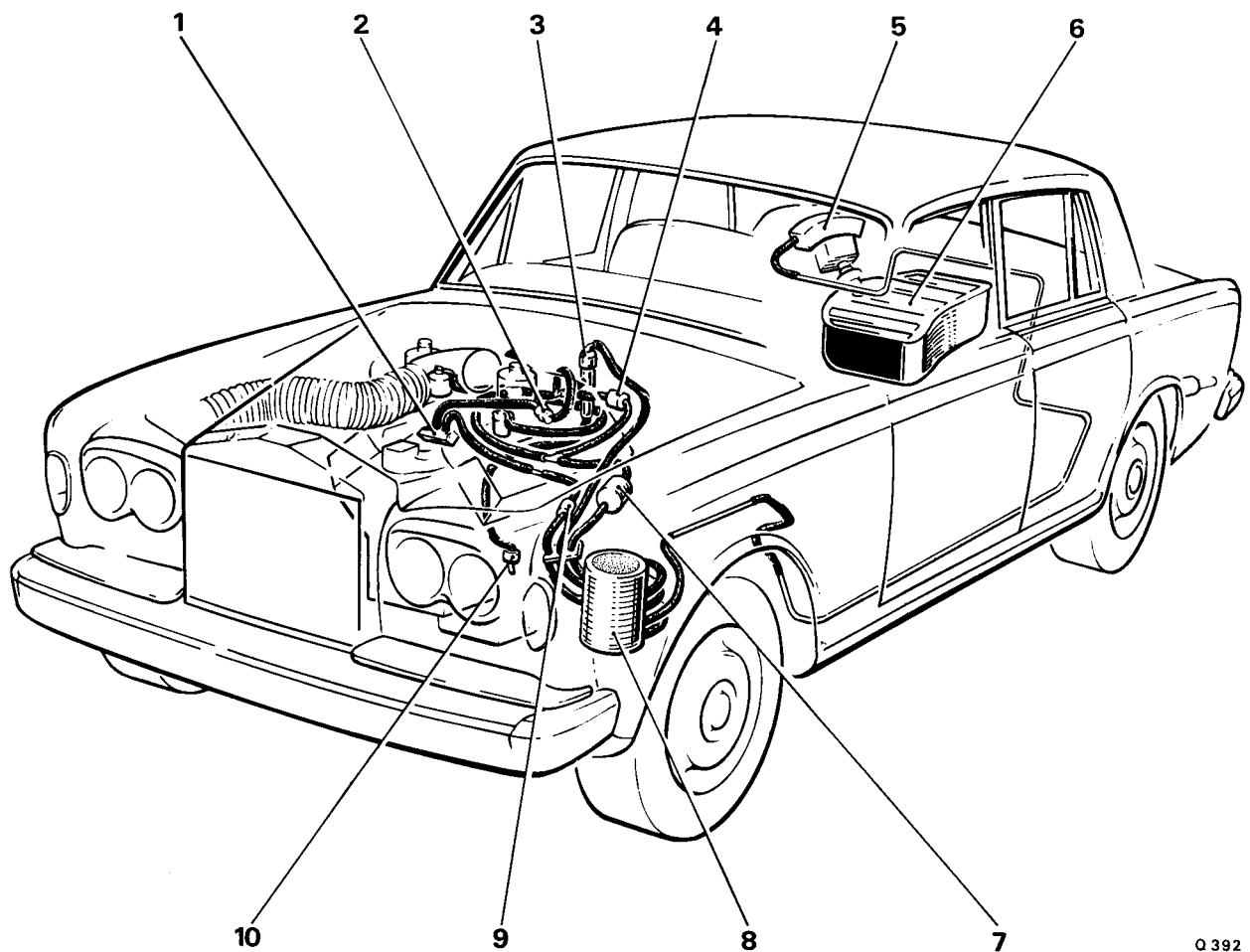

Q 392

FIG. 11 FUEL EVAPORATION EMISSION CONTROL SYSTEM—GENERAL VIEW

- | | |
|-----------------------------|-------------------------------------|
| 1 Vacuum manifold | 6 Fuel tank assembly |
| 2 Anti 'run-on' solenoid | 7 Weakener filter |
| 3 Float chamber vent valve | 8 Evaporative loss control canister |
| 4 Weakener cut-off solenoid | 9 Purge line filter |
| 5 Fuel trap assembly | 10 Float chamber drain valve |

Chapter U

Fuel tank assembly

The fuel tank assembly consists of the fuel tank, expansion tank and fuel trap assembly (see Fig. 12).

The fuel tank is vented from three positions to a fuel trap assembly which is mounted above the fuel filler. One vent is from the fuel filler neck and the other two vents from the fuel tank.

The three vent lines join at a common junction block situated adjacent to the fuel filler neck, the main vent line then encircles the fuel tank before passing to the fuel trap assembly.

From the fuel trap, a vent line passes under the floor of the car to the evaporation loss control canister.

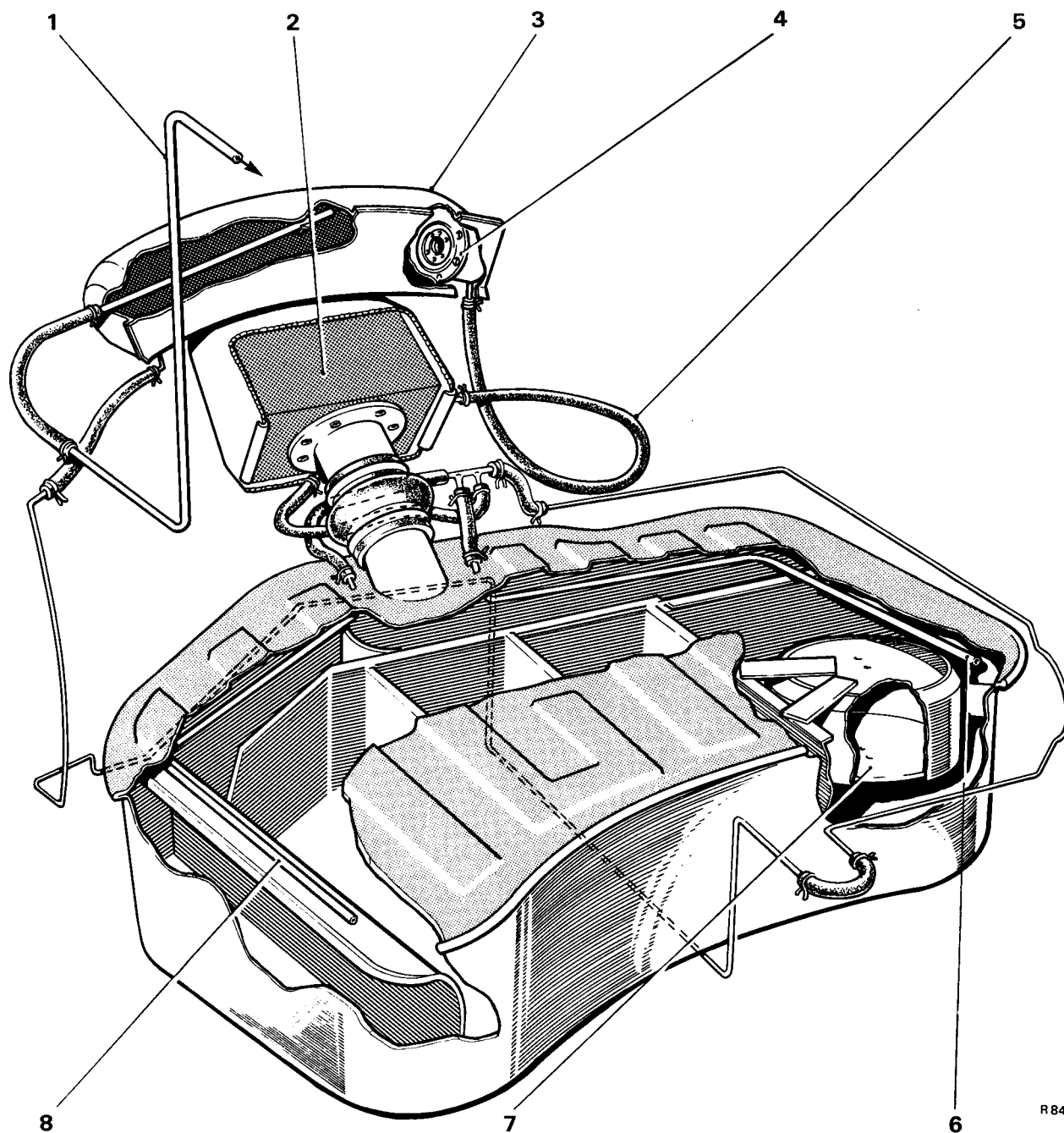

FIG. 12 FUEL EVAPORATION EMISSION CONTROL SYSTEM—FUEL TANK

- | | | |
|---|------------------------------------|------------------|
| 1 Connection to evaporation loss control canister | 3 Fuel trap | 5 Valve vent |
| 2 Fuel filler box | 4 Combined relief and vacuum valve | 6 Vent pipe |
| | | 7 Expansion tank |
| | | 8 Vent pipe |

Purge line

The purge line consists of a rubber hose, passing from the lowest connection on the canister through the valance junction piece to the vacuum manifold. Incorporated into this hose is the purge line filter and restrictor.

When the engine is running, air drawn through the canister filter and carbon picks up the stored fuel vapours and passes them via the hose, to the induction manifold. The restrictor in the line controls the flow rate at between 50 cu. ft. per hr. and 70 cu. ft. per hr. (1.41 cu. m. per hr. and 1.98 cu. m. per hr.) to maintain carburettor metering accuracy and the paper element line filter is fitted to prevent blockage of the restrictor.

Purge line filter—To remove

1. Using special pliers (RH 8090) remove the two steel retaining clips situated on either side of the unit.
2. Slacken the setscrew which secures the nylon retaining clip.
3. Withdraw the component from the clip.

Purge line filter—To fit

Fit the purge line filter by reversing the procedure given for removal noting the following points.

1. Ensure that the rubber hoses are in a good condition and new hose retaining clips are used.

Purge flow rate—To check

Check the purge flow rate as follows.

1. Disconnect the hose from the engine side of the purge line filter and insert a flowmeter and stand assembly (RH 8725) into the line. The flowmeter is a rotameter type capable of measuring between 50 cu. ft/hr. and 70 cu. ft/hr. (1.41 cu. m/hr. and 1.98 cu. m/hr.). The pressure drop across the meter is not to exceed 2 in. Hg. (5.08 cm. Hg.).
2. Start and run engine at idle speed, the flowmeter reading should be between 50 cu. ft/hr. and 70 cu. ft/hr. (1.41 cu. m/hr. and 1.98 cu. m/hr.).
3. If the flow is less than 50 cu. ft/hr. (1.41 cu. m/hr.) stop the engine and remove the purge line restrictor (see Fig. 5). Fit a piece of straight metal pipe with an internal bore larger than 0.187 in. (4.76 mm.), in the place of the restrictor.

4. Start and run the engine at idle speed, ensure that the flow is now in excess of 70 cu. ft/hr. (1.98 cu. m/hr.).
5. If the flow is less than 70 cu. ft/hr. (1.98 cu. m/hr.) check the following.
 - (i) an air leak in any of the vacuum hoses connected to the vacuum manifold (see Fig. 5).
 - (ii) a blockage in the vacuum manifold or any of the connecting hoses (see Fig. 5).
6. Rectify any air leaks or blockages found in the system. Repeat Operation 4.
7. Stop the engine and fit the purge line restrictor.
8. Start the engine and check the flow rate as detailed in Operation 2.
9. If the flow is still incorrect fit a new restrictor and again repeat Operation 2.
10. Stop the engine, remove the flowmeter assembly and connect the hoses.

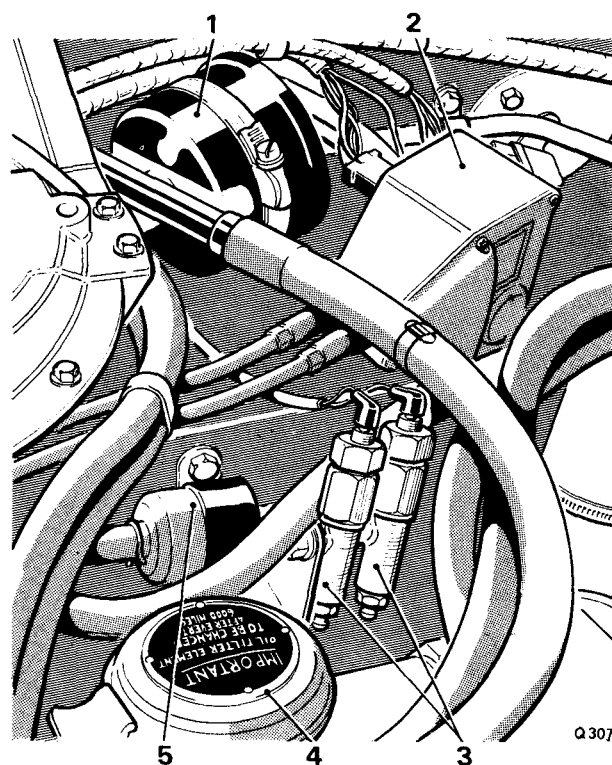

FIG. 13 POSITION OF MIXTURE WEAKENING DEVICE FILTER AND PURGE LINE FILTER

- 1 Weaker filter
- 2 Speed control system regulator
- 3 Hydraulic fluid accumulator pressure switches
- 4 Engine oil filler
- 5 Purge line filter

Chapter U

CRANKCASE EMISSION CONTROL SYSTEM

Crankcase emissions are controlled by a recirculatory closed breather system (see Fig. 14).

An insulated draught tube connects the crankcase via the oil filler which is fitted with a sealed cap, to the choke housing upstream of both the choke butterfly and the carburetters. A flame trap capsule containing three wire mesh discs is fitted in a housing at the crankcase end of the draught tube. Engine emission (blow-by) is drawn into the induction system via the draught tube, due to the depression in the choke housing.

Maintenance

1. The flame trap fitted to the breather pipe should be cleaned in the following manner, at the specified mileage.

2. Unscrew the setscrew securing the breather pipe connection to the oil filler pedestal; withdraw the connection from the pedestal (slight resistance may be felt due to the rubber 'O' ring connections).

3. Withdraw the connection from the pipe flange and collect the restrictor.

4. Wash the flame trap assembly in clean petrol, then dry with a high pressure air line. The flame trap assembly consists of 3 gauzes crimped together as shown in Figure 14.

5. To clean the adapter fitted to the choke housing, remove the single setscrew from the breather pipe end connection and detach the pipe.

6. Clean the adapter fitted to the choke housing and ensure that the holes in the adapter are clear.

7. Assembly of the flame trap and breather pipe is in the reverse order, ensuring that the 'O' rings are in good condition.

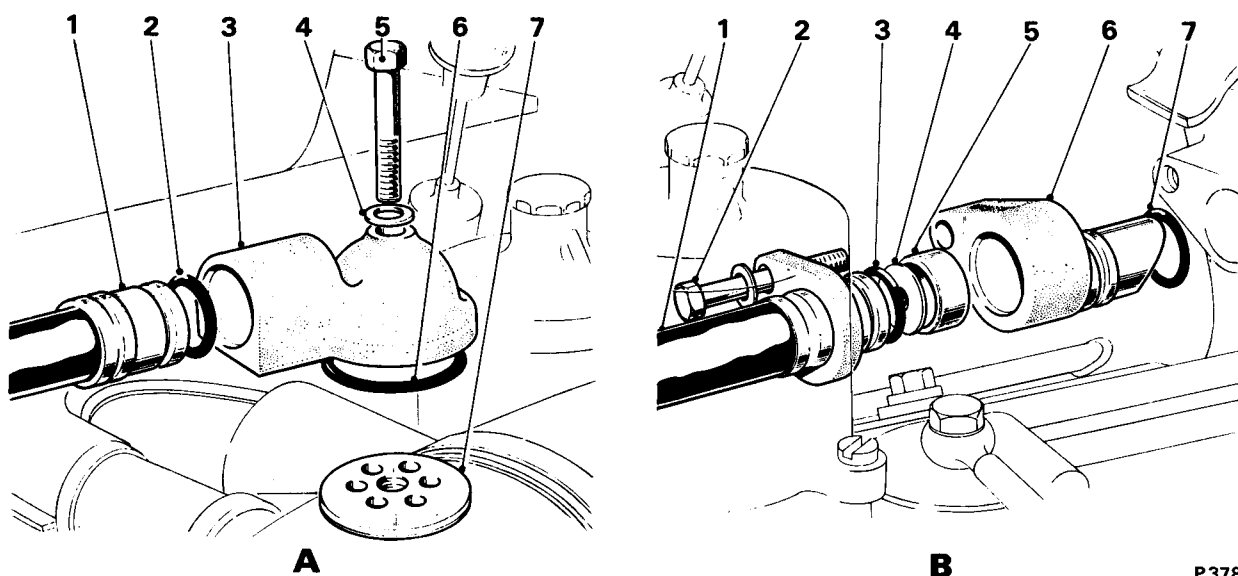

FIG. 14 EXPLODED VIEW OF CRANKCASE EMISSION CONTROL PIPE

Diagram A
 1 Pipe
 2 'O' ring
 3 Connection
 4 Washer
 5 Setscrew
 6 'O' ring
 7 Adapter

Diagram B
 1 Pipe
 2 Setscrew
 3 'O' ring
 4 Restrictor
 5 Flame trap
 6 Connection
 7 'O' ring

EMISSION CONTROL SYSTEMS (ELECTRICAL COMPONENTS)

The electrical components described in this section would normally appear in Chapter M—Electrical System, however, as they are only used in connection with the emission control system it is thought more practical to include the information in this Chapter.

The components concerned are as follows.

- (i) The exhaust gas recirculation primary valve lock-out switch.
- (ii) The exhaust gas recirculation secondary valve lock-out switch.
- (iii) The exhaust gas recirculation valve cut-off solenoids.
- (iv) The air diverter valve vacuum operated micro-switch.
- (v) The air diverter valve cut-out solenoid.
- (vi) The anti 'run-on' solenoid.
- (vii) The weakener cut-off solenoid valve.
- (viii) The weakener cut-off solenoid switch.

Note The temperatures quoted throughout this section for the various switches are nominal operating temperatures and in service, a plus or minus tolerance of a few degrees may be found.

Exhaust gas recirculation lock-out switch —To remove

The bi-metal lock-out switches are situated in the engine coolant thermostat housing and outlet elbow (see Fig. 15).

1. Remove the radiator filler cap and drain the engine coolant.
2. Disconnect the electrical lead.
3. Unscrew and remove the three 2 B.A. setscrews, spring washers and plain washers from the appropriate switch.
4. Free the joint and withdraw the respective lock-out switch.

Exhaust gas recirculation lock-out switch —To fit

Fit the lock-out switch by reversing the procedure given for removal, noting the following points.

1. Each setscrew has one spring and one plain washer.
2. The joint faces must be clean and a new gasket fitted.

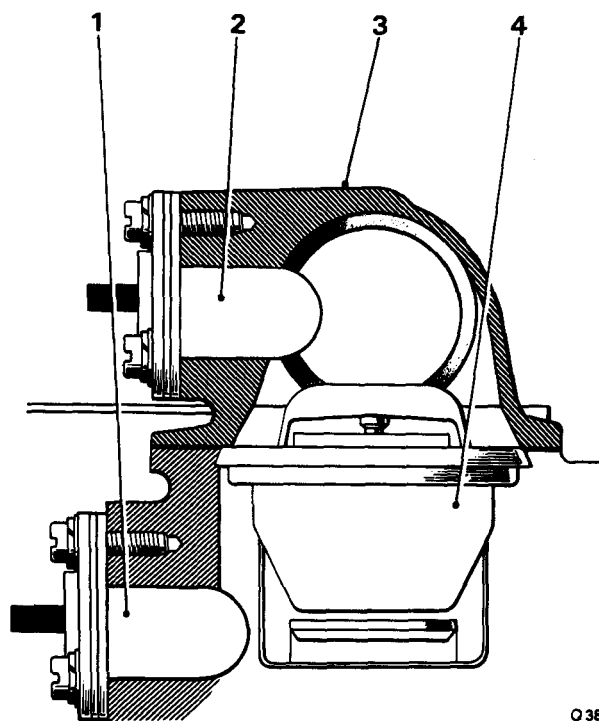

Q385

**FIG. 15 EXHAUST GAS RECIRCULATION
LOCK-OUT SWITCHES**

- 1 Secondary valve lock-out switch
- 2 Primary valve lock-out switch
- 3 Thermostat outlet elbow
- 4 Engine coolant thermostat

Chapter U

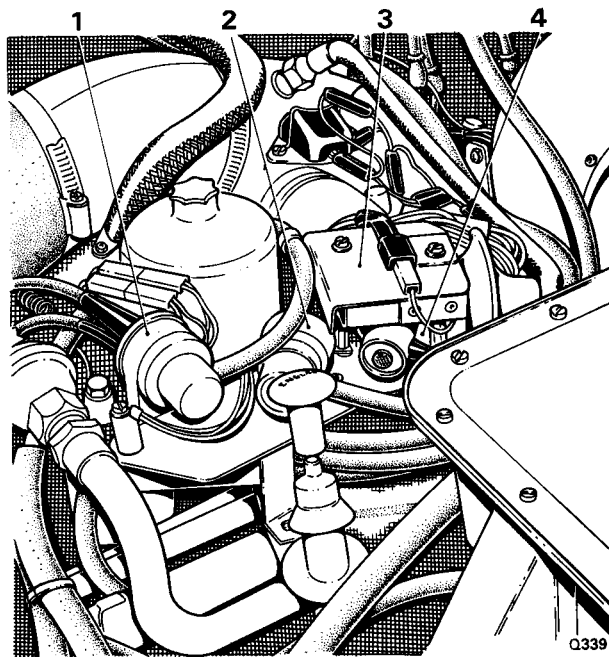

FIG. 16 SOLENOID PLATFORM

- 1 Anti 'run-on' solenoid
- 2 E.G.R. primary valve cut-out solenoid
- 3 E.G.R. secondary valve micro-switch assembly
- 4 E.G.R. secondary valve cut-out solenoid

**Exhaust gas recirculation lock-out switch
—To check**

1. Disconnect the electrical connection from the switch.
2. Connect one side of a test lamp to the switch contact of the lock-out switch to be tested and the other side to a known good electrical supply.
3. Ensure that the engine is cold and switch on the ignition.
4. Check that the test lamp bulb is illuminated.
5. **Primary valve lock-out switch**—Start and run the engine, as the coolant temperature rises to 14°C. (57°F.) the test lamp bulb should extinguish.
6. Stop the engine and allow to cool, noting that as the coolant temperature drops to 12°C. (54°F.) the test lamp bulb again illuminates.
5. **Secondary valve lock-out switch**—Start and run the engine, as the coolant temperature rises to 44°C. (111°F.) the test lamp bulb should extinguish.
6. Stop the engine and allow to cool, noting that as the coolant temperature drops to 42°C. (108°F.) the test lamp bulb again illuminates.

Note Do not leave the ignition switched on for long periods of time when the engine is not running.

**Exhaust gas recirculation primary valve
cut-off solenoid**

The exhaust gas recirculation primary valve cut-off solenoid is the middle solenoid of three solenoids situated on a small platform, adjacent to the 'B' bank carburetter (see Fig. 16).

**Exhaust gas recirculation primary valve
cut-off solenoid—To remove**

1. Detach the electrical connections, noting the position of the connections to assist identification when assembling.
2. Unscrew the two 'cheese-headed' mounting screws and withdraw the solenoid.

**Exhaust gas recirculation primary valve
cut-off solenoid—To fit**

Fit the cut-off solenoid by reversing the procedure given for removal.

**Exhaust gas recirculation primary valve
cut-off solenoid circuit wiring
—To check**

1. Connect a test lamp across the two Lucar connections to the solenoid.

Note Do not disconnect the two Lucar connections.

2. Ensure that the engine is cold.
3. Switch on the ignition and start the engine, noting that the bulb of the test lamp is illuminated.
4. Start and run the engine, as the coolant temperature rises to 14°C. (57°F.) the test lamp bulb should extinguish.
5. Depress the full throttle cut-out micro-switch plunger and check to ensure that the test lamp bulb illuminates. Release the plunger and the test lamp bulb should be extinguished.
6. Stop the engine and allow to cool, noting that as the coolant temperature drops to 12°C. (54°F.) the test lamp bulb again illuminates.

Note Do not leave the ignition switched on for long periods of time when the engine is not running.

**Exhaust gas recirculation primary valve
cut-off solenoid—To check**

1. Detach the solenoid hose at the weakener unit
2. Clean the end of the hose.
3. Switch on the ignition.

Note Do not leave the ignition switched on for long periods of time when the engine is not running.

4. Place the hose in the mouth and apply suction.
5. If the operation of the solenoid is correct note that the following conditions apply and connect the hose to the weakener.

- (i) With an engine coolant temperature of below 14°C. (57°F.) sucking on the hose should not prompt any movement of the exhaust gas recirculation valve.

Disconnect the hose from the exhaust gas recirculation valve. Clean the end of the hose, place in the mouth and blow; it should be possible to blow down this hose as the solenoid is vented to atmosphere. Connect the hose to the exhaust gas recirculation valve.

- (ii) With an engine coolant temperature of above 14°C. (57°F.) sucking on the hose from the weakener unit should move the exhaust gas recirculation valve.
 - (iii) As the engine coolant temperature falls to 12°C. (54°F.) the conditions described in (i) should again apply.
6. If the operation of the solenoid is suspect, fit a new unit.

Exhaust gas recirculation secondary valve cut-in solenoid and vacuum operated micro-switch

This assembly is situated rearmost of the three solenoid assemblies mounted on a platform, adjacent to the 'B' bank carburetter (see Figs. 7 and 16).

Exhaust gas recirculation secondary valve cut-in solenoid and vacuum operated micro-switch—To remove

1. Detach the rubber hoses from the solenoid, solenoid vent and vacuum unit.

Note Each rubber hose should be labelled as it is detached, to facilitate identification during assembly.

2. Disconnect the electrical leads at their Lucar connections.
3. Unscrew and remove the two 2 B.A. screws which retain the micro-switch cover in position. Withdraw the cover.
4. Unscrew the two reach-nuts and withdraw the micro-switch assembly.
5. Unscrew and remove the two support pillars. Withdraw the solenoid assembly.
6. Collect the two distance pieces situated beneath the solenoid feet.

Exhaust gas recirculation secondary valve cut-in solenoid and vacuum operated micro-switch—To fit

Fit the secondary valve cut-in solenoid and vacuum operated micro-switch assembly by reversing the procedure given for removal.

Exhaust gas recirculation secondary valve cut-in solenoid and vacuum operated micro-switch circuit wiring—To check

1. Connect a test lamp across the two Lucar connections to the solenoid.

Note Do not disconnect the two Lucar connections.

2. Ensure that the engine is cold.
3. Switch on the ignition and start the engine, noting that the bulb of the test lamp is illuminated.
4. Start and run the engine until the coolant temperature rises to 44°C. (111°F.).
5. Stop the engine.
6. Switch on the ignition and note that the test lamp bulb is extinguished.
7. Start the engine and run at the idle speed, noting that the bulb of the test lamp is illuminated.

Exhaust gas recirculation secondary valve cut-in solenoid and vacuum operated micro-switch—To check

1. Disconnect the rubber hose from the vacuum unit.
2. Connect a suitable hand operated vacuum pump with a scale calibrated in ins. of Hg. (RH 8800) to the vacuum unit connection.
3. Draw a vacuum of at least 12 in. Hg. (30,5 cm. Hg.) and note that the micro-switch 'clicks' at approximately 10 in. Hg. (25,4 cm. Hg.) vacuum.
4. Allow the 12 in. Hg. (30,5 cm. Hg.) vacuum to decrease slowly and note that the micro-switch 'clicks' again as the vacuum falls to between 9.0 in. Hg. and 8.5 in. Hg. (22,9 cm. Hg. and 21,6 cm. Hg.).
5. Release the vacuum and remove the pump assembly. Re-connect the rubber hose

Exhaust gas recirculation secondary valve cut-in solenoid and vacuum operated micro-switch—To set

1. Unscrew and remove the two 2 B.A. screws which retain the micro-switch cover in position.
2. Remove the cover.

Chapter U

3. Disconnect the rubber hose from the vacuum unit.
4. Connect a suitable hand operated vacuum pump with a scale calibrated in ins. of Hg. (RH 8800) to the vacuum unit connection.
5. Draw a vacuum of 12 in. Hg. (30.5 cm. Hg.) with the pump. Allow the vacuum to decrease to 8.75 in. Hg. (22.2 cm. Hg.) and then seal the vacuum line to maintain the vacuum at the micro-switch.
6. Release the lock-nut and screw the spring

loaded plunger assembly in until the micro-switch is fully depressed (see Fig. 6).

7. Screw the spring loaded plunger assembly out until the micro-switch 'clicks'. Tighten the lock-nut.

8. Check the operation of the vacuum operated micro-switch as detailed in Exhaust gas recirculation secondary valve cut-in solenoid and vacuum operated micro-switch—To check.

9. Fit the micro-switch cover. Remove the vacuum pump and re-connect the rubber hose to the vacuum unit.

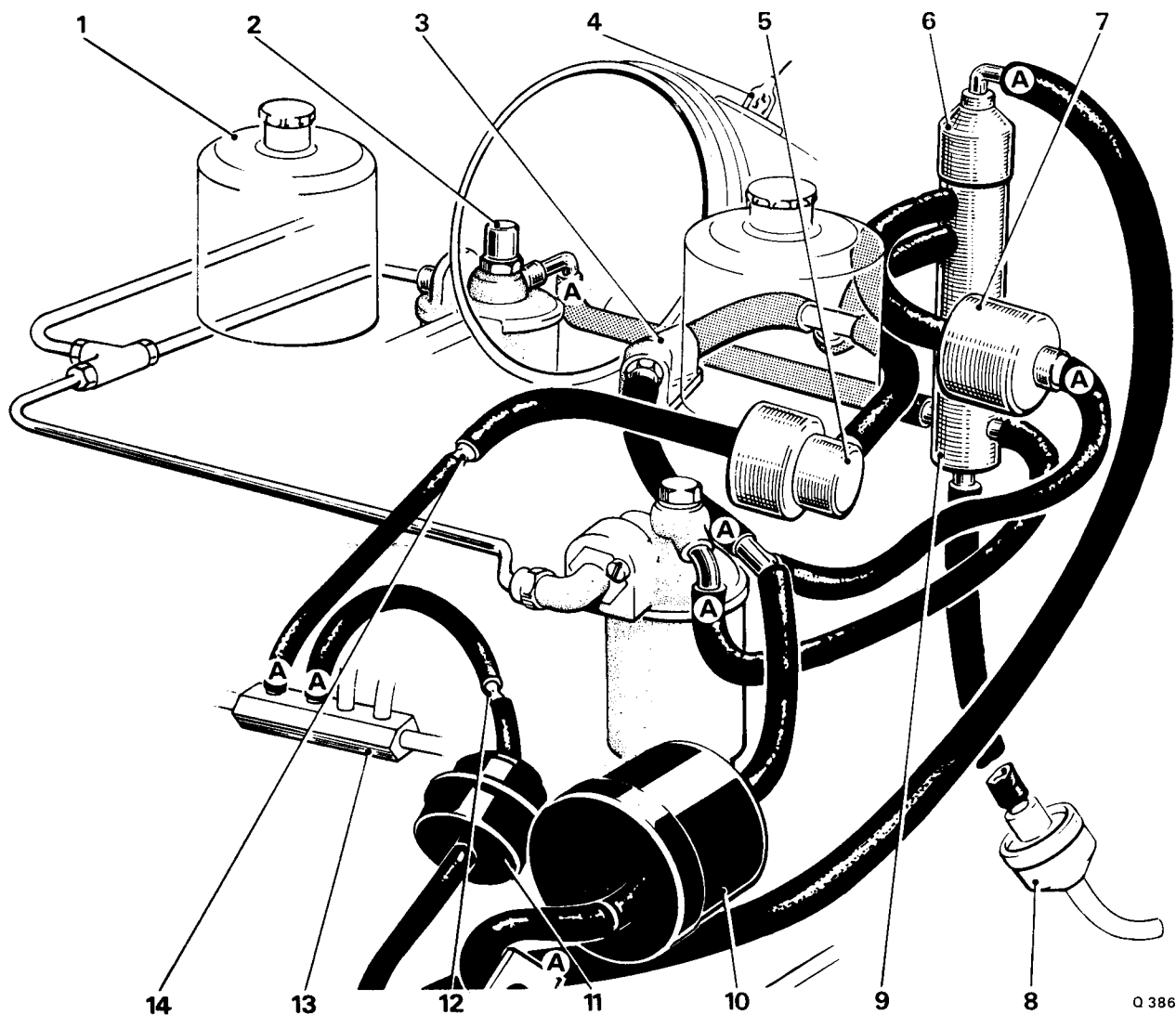

FIG. 17 CARBURETTER WEAKENING DEVICE

- | | |
|--|---|
| <p>A Hoses to be detached when removing carburetters</p> <p>1 'A' bank carburetter</p> <p>2 Float chamber pressure tapping</p> <p>3 Weakening device</p> <p>4 Bi-metal switch</p> <p>5 Anti 'run-on' solenoid</p> <p>6 Float chamber vent valve</p> | <p>7 Weakening device cut-off solenoid</p> <p>8 Float chamber drain valve</p> <p>9 Fuel receiver</p> <p>10 Weakener filter</p> <p>11 Purge line filter</p> <p>12 Purge line restrictor</p> <p>13 Vacuum manifold</p> <p>14 Restrictor</p> |
|--|---|

Exhaust gas recirculation full throttle cut-off micro-switch—To remove

1. Detach the two electrical leads at their Lucar connections.
2. Unscrew and remove the two small nuts and bolts which retain the micro-switch in position on the mounting bracket.
3. Withdraw the micro-switch.

Exhaust gas recirculation full throttle cut-off micro-switch—To fit

Fit the micro-switch by reversing the procedure given for removal. Finally, set the micro-switch.

Exhaust gas recirculation full throttle cut-off micro-switch circuit wiring—To check

1. Start and run the engine until normal operating temperature is attained.
2. Switch off the ignition.
3. Connect a test lamp in turn across the two Lucar connections to the primary and secondary exhaust gas recirculation cut-off solenoids.

Note Do not disconnect the Lucar connections.

4. Switch on the ignition and check that the test lamp bulb is extinguished.
5. Open the throttles to the full throttle position to activate the full throttle cut-off micro-switch and thereby, illuminate the test lamp bulb.

Exhaust gas recirculation full throttle cut-off micro-switch—To set

Prior to setting the exhaust gas recirculation system cut-off micro-switch, ensure that the following are correctly set.

- (i) Throttle linkage (*refer to Chapter K*).
- (ii) Carburetter linkage (*refer to page U181 of this Supplement*).
- (iii) Kick-down micro-switch (*refer to Chapter U*).

To set the cut-off micro-switch proceed as follows.

1. Depress the accelerator pedal until it touches the toeboard mounted kick-down micro-switch (further depression of the pedal requires increased effort).
2. Hold the throttle linkage in the position described in Operation I and release the lock-nut (*Fig. 8, item 2*) on the throttle lever (*item 3*).
3. Screw the spring loaded operating button away from the micro-switch.
4. When there is clearance at this point screw the spring loaded operating button toward the micro-switch until the micro-switch is heard to 'click'.

5. Tighten the lock-nut.
6. Depress the accelerator pedal further to operate the toeboard mounted kick-down micro-switch.
7. Adjust the full throttle stop (*Fig. 8, item 4*) to prevent overloading of the kick-down micro-switch. The full throttle stop should be set so that all throttle movement is stopped just prior to the operating button spring becoming fully compressed.

Air diverter valve vacuum operated micro-switch

This assembly is situated adjacent to the air diverter valve and air injection pump assemblies (*see Fig. 2, item 8*). The purpose of the unit is to assist in the protection of the exhaust catalyst (*see Catalyst over temperature protection on Page U157 of this Supplement*).

Air diverter valve vacuum operated micro-switch—To remove

To remove the assembly, carry out the procedure given on Page U173 of this Supplement under the heading 'Exhaust gas recirculation secondary valve cut-in solenoid and vacuum operated micro-switch—To remove'.

Air diverter valve vacuum operated micro-switch—To fit

Fit the assembly by reversing the procedure given for removal.

Air diverter valve vacuum operated micro-switch circuit wiring—To check

1. Connect a test lamp across the Lucar connections to the solenoid.

Note Do not disconnect the Lucar connections.

2. Start and run the engine at idle speed, noting that under these conditions (i.e. idle speed which produces a high manifold depression) the test lamp bulb illuminates.
3. Stop the engine, switch on the ignition and note that the test lamp bulb is extinguished.
4. Remove the test lamp.

Air diverter valve vacuum operated micro-switch—To check

1. Disconnect the hose from the induction manifold to the vacuum operated micro-switch, at the switch.
2. Connect a suitable hand operated vacuum pump (RH 8800) to the vacuum switch.

Chapter U

3. Draw a vacuum of at least 6 in. Hg. (15,24 cm. Hg.) and note that the switch 'clicks' at approximately 3 in. Hg. (7,62 cm. Hg.).
4. Allow the 6 in. Hg. (15,24 cm. Hg.) vacuum to decrease slowly and note that the micro-switch 'clicks' again as the vacuum falls to between 2.7 in. Hg. (6,8 cm. Hg.) and 2.2 in. Hg. (5,58 cm. Hg.).
5. Release the vacuum and remove the pump assembly. Re-connect the rubber hose.

Air diverter valve vacuum operated micro-switch—To set

1. Unscrew and remove the two 2 B.A. screws which retain the micro-switch cover in position.
2. Remove the cover.
3. Disconnect the hose from the induction manifold to the vacuum operated micro-switch, at the switch.
4. Connect a suitable hand operated vacuum pump (RH 8800) to the vacuum switch.
5. Draw a vacuum of 6 in. Hg. (15,24 cm. Hg.) on the hand pump and then allow the vacuum to decrease to 2.5 in Hg. (6,35 cm. Hg.), seal the vacuum line to maintain this vacuum at the micro-switch.
6. Release the lock-nut (*see Fig. 6*) and screw the spring loaded plunger in until the micro-switch is fully depressed.
7. Screw the spring loaded plunger assembly out until the micro-switch 'clicks'. Tighten the lock-nut.
8. Check the operation of the vacuum operated micro-switch as detailed in Air diverter valve vacuum operated micro-switch—To check.
9. Fit the hose to the vacuum operated micro-switch.

Air diverter valve cut-out solenoid—To check

1. Disconnect the hose from the air diverter valve (*see Fig. 3, item 14*) and attach an extension to the hose.
2. Switch on the ignition and apply a suction to the hose; air should pass freely down the hose.

Note If the suction is applied to the hose by the mouth, it must be for a short period only as vapour from the induction manifold will be inhaled.

3. Start and run the engine at idle speed. Apply a suction to the hose extension piece, noting that air cannot be drawn down the hose.
4. Stop the engine, remove the extension and re-connect the hose to the air diverter valve.

Anti 'run-on' solenoid

The anti 'run-on' solenoid is situated on a platform adjacent to 'B' bank carburetter; it is the foremost of the three solenoids fitted on the platform.

The use of low octane fuel often causes an engine to 'diesel' (i.e. continue to run-on after the ignition has been switched off, particularly when the engine is hot). To prevent this condition arising an anti 'run-on' solenoid is connected to the weakener unit signal line (*see Fig. 17*).

When the ignition is switched off the solenoid opens and connects the weakener system to the induction manifold, thus creating a high float chamber depression which cuts off the supply of fuel.

Anti 'run-on' solenoid—To remove

1. Disconnect the rubber hose from either side of the solenoid.
2. Disconnect the two electrical leads at their Lucar connections.
3. Unscrew and remove the two screws situated one on either side of the solenoid body.
4. Withdraw the anti 'run-on' solenoid.

Anti 'run-on' solenoid—To fit

Fit the anti 'run-on' solenoid by reversing the procedure given for removal.

Anti 'run-on' solenoid circuit wiring—To check

1. Connect a test lamp across the two Lucar connections to the solenoid.
Note Do not disconnect the two Lucar connections.
2. Switch on the ignition and check that the test lamp bulb illuminates.
3. Switch off the ignition and check that the test lamp bulb is extinguished.

Anti 'run-on' solenoid—To check

1. Detach the hose from the solenoid to the 'Tee' piece at the solenoid end and connect a piece of hose of identical internal diameter but of suitable length, to the solenoid.
2. Clean the open end of the hose.
3. Switch on the ignition.
4. Place the hose in the mouth and blow down the hose.

5. If the operation of the solenoid is correct note that the following conditions apply and connect the original hose to the solenoid.

- (i) With the ignition switched on it should not be possible to blow down the hose.
- (ii) With the ignition switched off the solenoid is de-energised and it should be possible to blow down the hose.

6. Replace hose that was removed in Operation 1.

If the operation of the solenoid is suspect, carry out the following test before fitting a new unit.

1. Remove the cap from the pressure tapping on 'A' bank carburetter float chamber. Connect a manometer, capable of measuring between 0 in. and 6 in. (0 cm. and 15,24 cm.), to the pressure tapping connection.

2. Start and run the engine at idle speed (600 r.p.m.).

3. Switch off the ignition and observe the reading on the manometer. The reading should increase momentarily to approximately 6 in. (15,24 cm.) of H₂O as the engine stops.

If the reading does not increase check the following.

- (a) A blockage in the hose from the 'Tee' piece in the weakener hose to the anti run-on solenoid.
- (b) A blockage in the hose route (2 hoses joined by a restrictor/connector from the anti 'run-on' solenoid to the vacuum manifold).
- (c) Incorrect wiring to the anti 'run-on' solenoid.

Weakener cut-off solenoid

Refer to page U21

Weakener valve cut-off switch

Refer to page U21

THE CARBURETTERS AND AUTOMATIC CHOKE SYSTEM

CARBURETTER

Data

Carburetters	Two S.U. HD8 diaphragm type.
Choke size	2.00 in. (5,08 cm.).
Jet size—		
spring loaded needle		
type	0.100 in. (2,44 mm.).
Jet needle—		
spring loaded type	..	BCQ.
Carburetter—		
air valve piston spring		Red/Blue.

CARBURETTER MIXTURE WEAKENING DEVICE

Description

In addition to the description given on pages U24 and U25, the following information is applicable.

Anti-diesel device (anti 'run-on' solenoid)

The use of low octane fuel causes the engine to 'diesel' (i.e. continue to run-on after the ignition has been switched off) when it is hot. To prevent this from happening an anti 'run-on' solenoid valve is fitted into the weakener signal line. When the ignition is switched off this valve opens and connects the weakening system to the induction manifold thus creating a high float chamber depression which cuts off the fuel supply.

Chapter U

Carburettor overrun valves

During overrun (i.e. when decelerating with the throttles closed), insufficient mixture is supplied to the engine to maintain satisfactory combustion. The overrun valves alleviate this condition by allowing some mixture to pass through the throttle plates (butterflies) at high inlet manifold depressions.

An overrun valve consists of a small disc retained in each throttle plate by a spring loaded plunger. Under normal conditions the disc is seated against the throttle plate. When the throttle is suddenly closed, the increased inlet manifold depression lifts

the disc from its seating and allows a metered quantity of air/fuel mixture to pass through the throttle plate.

The action of the overrun valves maintains satisfactory combustion on overrun, thus reducing hydrocarbon emissions and controlling catalyst temperatures.

After the sudden closure of the throttles and as soon as the manifold depression falls, the overrun valve disc returns to its seat on the throttle plate.

Throttle damper

The throttle damper prevents rapid throttle closure which would suddenly drop the inlet manifold

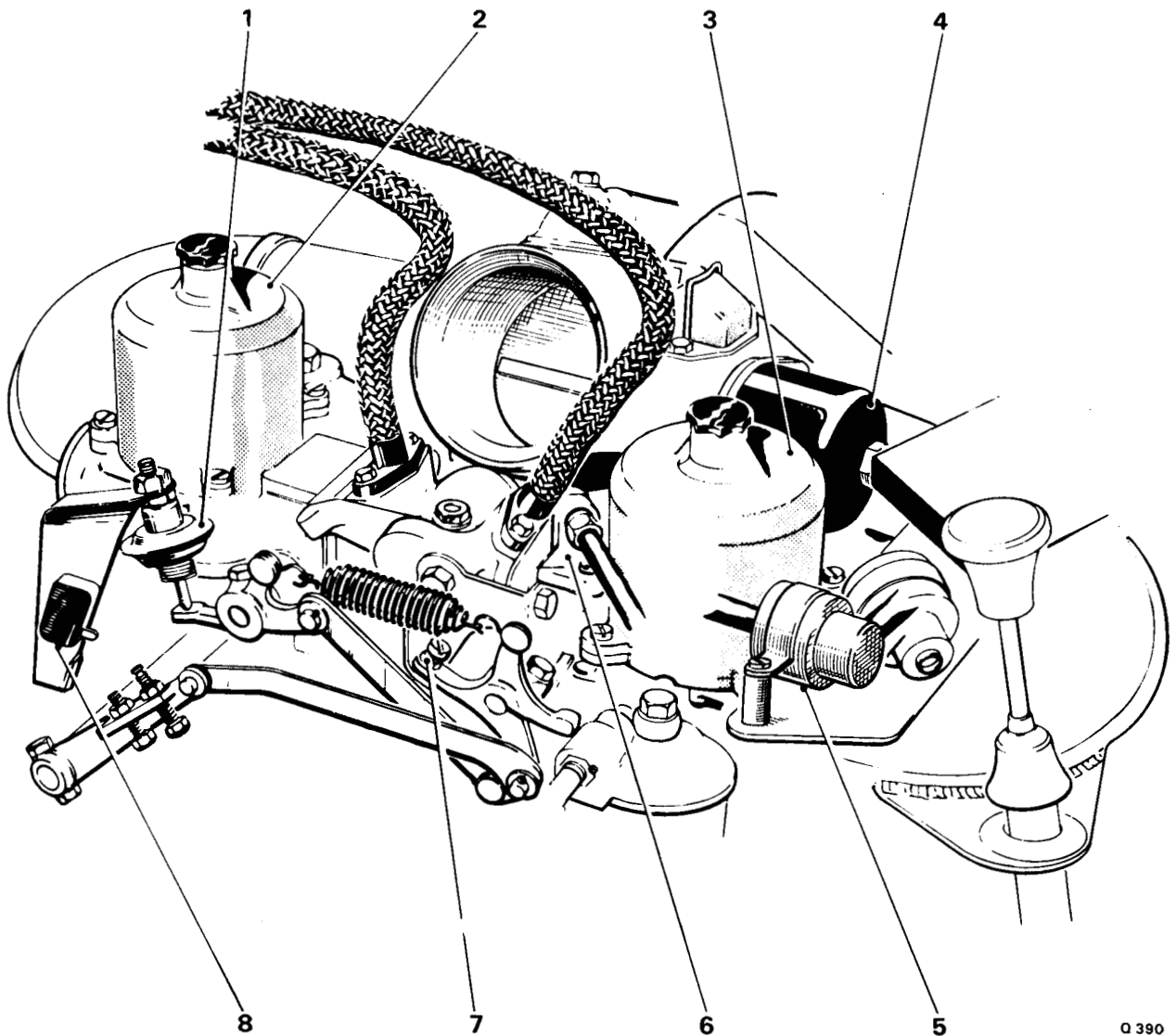

FIG. 18 VIEW OF CARBURETTERS

Q 390

- 1 Throttle damper
- 2 'A' bank carburettor
- 3 'B' bank carburettor
- 4 Choke bi-metal housing

- 5 Anti 'run-on' solenoid
- 6 Mixture weakening device
- 7 Idle stop
- 8 Full throttle (E.G.R.) cut-off micro-switch

pressure causing vapourisation of fuel from the manifold walls and a sudden increase in mixture strength.

Temperature controlled air intake

To ensure rapid warm-up and improve control of the air/fuel ratio a temperature controlled air intake is fitted (*see Fig. 22*).

A vacuum operated blending valve attached to the air cleaner assembly is controlled by a thermal sensor in the air intake elbow. This valve blends hot air from a pick-up point (scoop) adjacent to the exhaust manifold with cold air from under the front wing; thus maintaining a constant temperature of the intake air as it enters the carburetters.

Temperature controlled air intake—To check

1. Disconnect the air intake hose at the butterfly housing and check that the correct temperature sensor is fitted, this should be colour coded green.
2. Disconnect the hose from the temperature sensor to the underwing air silencer, at the temperature sensor.
3. Clean the end of the hose, place in the mouth and apply a vacuum by sucking. Check that there is no air leak. Release the vacuum sharply and listen for the vacuum motor within the wing to 'click' open.
4. Reconnect the hoses.

Note If there is an air leak or the operation of the temperature controlled air intake is suspect, remove the right-hand front underwing sheet and check the hose connection to the vacuum motor; also observe the operation of the temperature flap.

Throttle stop vacuum actuator assembly

The throttle stop vacuum actuator assembly is not fitted to cars produced to the 1976 specification.

OVERHAUL

Carburetters—To remove

Before commencing to remove the carburetters observe the following points.

1. When disconnecting the various hoses, pipes and wiring connections ensure that they are suitably labelled to assist identification when assembling.
2. Ensure that **all** open ends of pipes, hoses, etc., are suitably blanked off to prevent the ingress of dirt, etc.

To remove the carburetters proceed as follows.

1. Disconnect the battery.
2. Unscrew and remove the two $\frac{7}{16}$ in. A/F nuts from the joint in the small diameter exhaust pipe, situated below the exhaust gas recirculation valves. Free the joint.

3. Detach the following rubber hoses (*see Fig. 17*).
 - (i) The hose from the weakening device cut-off solenoid to the small diameter 'tee' piece, at the solenoid.
 - (ii) The hose from the float chamber vent valve to the valance connection block, at both ends.
 - (iii) The hose from the weakening device to the 'tee' piece.
 - (iv) The hose from the vacuum manifold to the anti 'run-on' solenoid.
 - (v) The overflow hoses from the carburetter float chambers to the fuel receiver.
 - (vi) Both hoses from the inlet manifold tappings (*see Fig. 7*).
4. Detach the following electrical connections.
 - (i) The two connections at the full throttle E.G.R. cut-out micro-switch, also release the two rubber clips which hold the loom to the 'B' bank float chamber fuel feed pipe.
 - (ii) The two connections to the anti 'run-on' solenoid, including the earth wires from beneath one of the solenoid mounting feet. Also, release the loom from the clip situated on the solenoid mounting platform.
 - (iii) The two connections to the E.G.R. secondary valve cut-in micro-switch and one connection above the micro-switch assembly.
 - (iv) The connections to both E.G.R. cut-out solenoids at the Lucar connection block.
 - (v) The choke solenoid connections, also release the wires from the adjacent clip.
 - (vi) The weakener cut-off bi-metal switch.
5. Remove the crankcase breather pipe from the choke butterfly housing; withdraw the connection from the end of the pipe.
6. Disconnect the choke stove pipe from the choke housing.
7. Disconnect the choke stove pipe from the choke bi-metal coil housing connection.
8. Unscrew the worm drive clips securing the air intake hose in position; remove the hose.

Unscrew the worm drive clip securing the metal intake elbow to the butterfly choke housing. Disconnect the two rubber hoses connected to the thermal sensor situated inside the metal elbow. Withdraw the elbow.
9. Remove the engine oil dipstick.
10. Unscrew and remove the 2 B.A. bolt, nut and washer securing the throttle linkage to the 'fore and aft' manifold shaft lever; this connection is adjacent to the 'A' bank carburetter.
11. Withdraw the throttle linkage from the manifold shaft.
12. Disconnect the main fuel feed pipe.

Chapter U

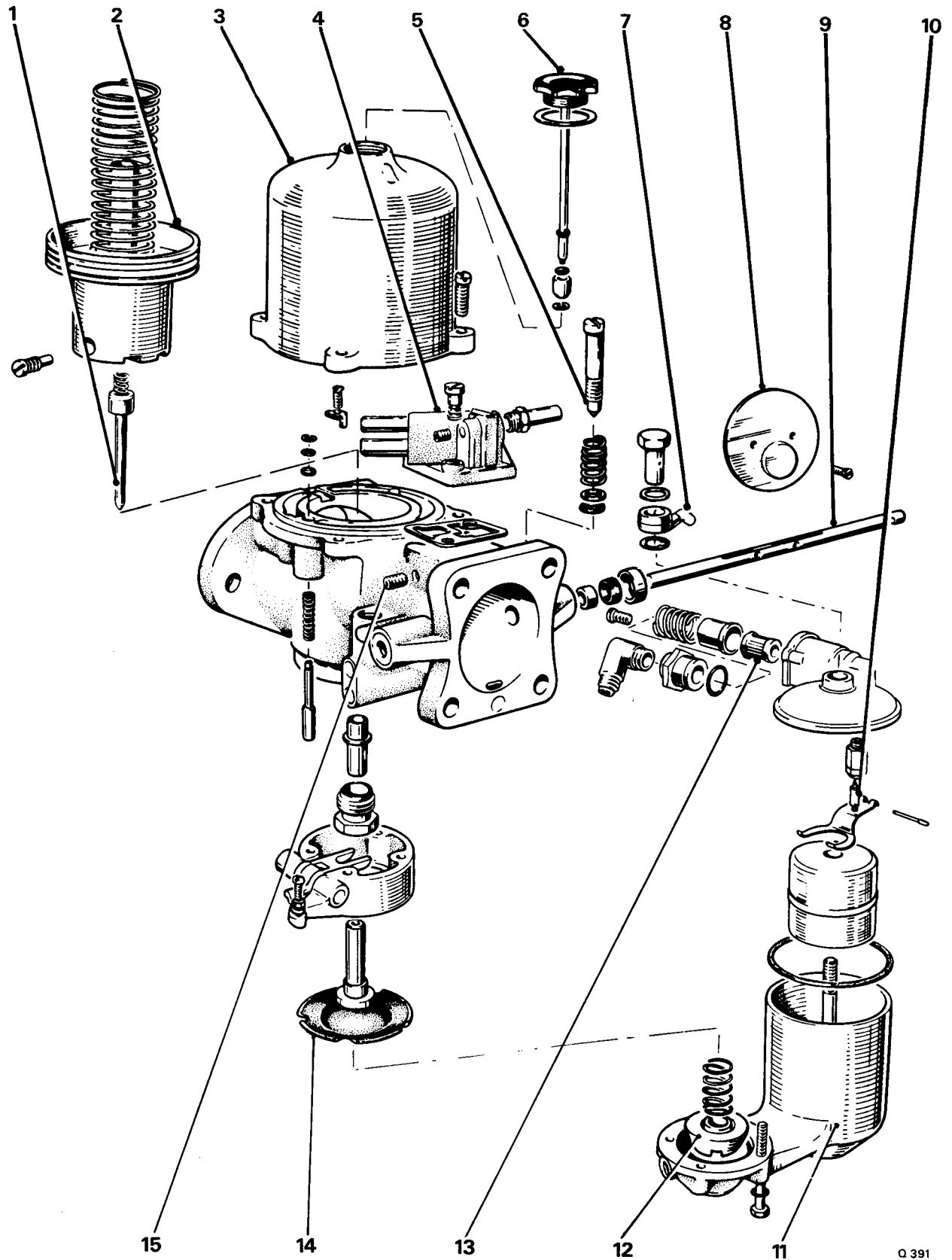

Q 391

FIG. 19 'B' BANK CARBURETTER

- | | | |
|--|---|---|
| <ul style="list-style-type: none"> 1 'Swing' needle assembly 2 Piston 3 Suction chamber 4 Mixture weakening device ('B' bank carburettor only) 5 Volume screw | <ul style="list-style-type: none"> 6 Damper 7 Overflow pipe 8 Throttle plate (incorporating overrun valve) 9 Spindle 10 Float needle | <ul style="list-style-type: none"> 11 Float chamber 12 Anti-boiling device 13 Filter element 14 Jet diaphragm 15 E.G.R. signal adjusting screw ('B' bank carburettor only) |
|--|---|---|

13. Remove the air horns, choke butterfly housing carburetters and 'Tee' piece as one complete assembly. The assembly is secured to the induction manifold by a $\frac{1}{2}$ in. A/F setscrew situated centrally on the carburetter 'Tee' piece and located by two dowel pins.

14. Before lifting the carburetters assembly from the engine check to ensure that no wires, hoses or other joints have been left connected.

Dismantle the carburetters from the 'Tee' piece and air horns as follows.

15. Unscrew the four setscrews retaining the E.G.R. distribution pipes in position on the carburetter 'Tee' piece.

16. Remove the exhaust gas recirculation valves from the carburetters assembly (*refer to Exhaust gas recirculation valves—To remove in this Supplement*) noting that the distribution pipes can be left connected to the E.G.R. valves.

17. Slacken the pinch bolt and remove the fast-idle lever from the 'A' bank carburetter butterfly spindle.

18. Unscrew and remove the two $\frac{1}{2}$ in. A/F nuts from the two setscrews securing the air horn to 'B' bank carburetter. Disconnect the rubber hoses from the solenoids. Unscrew the cheese-headed screw from the solenoid platform mounting foot adjacent to the engine oil dipstick tube, collect the nut and washer, and withdraw the solenoid platform assembly.

19. Remove the four setscrews securing the two air horns to the carburetters, collect the full throttle stop bracket assembly with the throttle damper from 'A' bank carburetter. Remove the air horns.

20. Disconnect the fuel feed pipe from the float chambers.

21. Disconnect and remove the throttle spring.

22. Completely remove the two pinch bolts securing the throttle levers to the 'A' and 'B' bank carburetter butterfly spindles; remove the levers.

23. Remove the nuts and washers securing both carburetters to the 'Tee' piece, remove the carburetters.

Carburetters—To fit

Fit the carburetters by reversing the procedure given for their removal noting the following points.

1. Fit new gaskets and washers to all joints.
2. Examine the floats for damage or punctures; fit the floats to their respective float chambers.
3. Renew the lid gaskets.
4. Fit the gaskets to the lids then fit the lids to the chambers.
5. Secure the lids and pipes to the float chambers.
6. Examine the paper filter elements for cleanliness and damage; renew if necessary.

7. Ensure that the 'O' rings on the petrol inlet unions are in good condition; renew if necessary. Fit the paper filter elements, spring retainers, springs and inlet unions to each float chamber lid. Secure the inlet unions with the retaining screws.

8. Fill the damper piston with an approved oil; the oil level should be approximately 0.5 in. (12.7 mm.) below the top of the piston rod. Do not overfill.

Carburetters—To set

The carburetters fitted to these cars are adjusted at the factory using **special equipment** to ensure that their settings comply with the current emission control regulations.

Under normal circumstances the carburetters should not require adjustment in service.

If however, adjustment is found necessary due to inadvertent disturbance or replacement of a component, set the carburetters by carrying out the following operations in the sequence given.

- A. Set throttle linkage and temporarily set engine idle speed. Check linkage clearances.
- B. Set cold start 'fast-idle' cam.
- C. Tune carburetters.
- D. Set cold start 'fast-idle' speed.
- E. Set the throttle damper plunger.
- F. Set the kick-down micro-switch.
- G. Set full throttle stop and full throttle E.G.R. cut-off micro-switch.

Contra-rotating throttles—To fit and set (see Fig. 20)

1. Assemble 'A' bank and 'B' bank throttle levers (*items 7 and 13*) onto the carburetter spindles.
2. Fit the setting jig (RH 8880) into position on the throttle levers.
3. Fully close 'B' bank carburetter butterfly (*item 8*).
4. Tighten the pinch bolt securing 'B' bank throttle lever.
5. Fully close 'A' bank carburetter butterfly (*item 3*).
6. Tighten the pinch bolt securing 'A' bank throttle lever.
7. Fit the throttle spring (*item 4*) to the throttle levers.
8. Remove the setting jig from the throttle levers.
9. Fit the cross link (*item 12*) and the eccentric throttle adjuster (*item 5*) onto the throttle levers, ensuring that both throttle butterflies are closed when adjusting and tightening the eccentric adjuster.

Note The eccentric pin should be set in the lowest position possible.

Chapter U

10. Ensure that the tang of the throttle guard (*item 6*) has a clearance of between 0.050 in. (1.27 mm.) and 0.070 in. (1.78 mm.) with the cross link and also that the tang does not foul the throttle spring. If necessary bend the tang to give these clearances.
11. Check that the throttle linkage moves freely.
12. Fit the idle stop screw (*item 10*) and adjust until it just contacts the stop bracket (*item 11*) with the throttle butterflies remaining in the closed throttle position.
13. Screw down the idle stop screw $\frac{1}{2}$ turn and tighten the lock-nut.
14. Screw both of the carburetter volume screws (*items 2 and 9*) fully in.
15. Fit the throttle damper (*item 1*) with the damper spindle compressed 0.187 in. (4.75 mm.) when throttle lever (*item 13*) is in the closed position. Ensure that the damper rod contacts the throttle lever centrally 0.20 in. (5.1 mm.) from the outer edge.
16. Connect the drive link (*item 14*) to the manifold shaft lever (*item 15*).
17. Operate the linkage to ensure free movement.
18. With the throttles in the closed position check that the 'A' bank control shaft to control rod lever

(*item 16*) on the rear of the manifold shaft is in line with the front manifold shaft lever (*item 15*). Tighten the securing bolts on both levers.

19. Operate the mechanism; check for freedom of movement within the linkage and also clearance with the various engine components.

20. To set the remainder of the linkage from the control rod lever on the rear of the manifold shaft to the accelerator pedal refer to Chapter T—Part 2.

CARBURETTER TUNING

Preliminary checks

Before tuning the carburetters the following checks should be carried out.

Ensure that the vehicle is in 'Park', the parking brake firmly applied and that the gear range actuator thermal cut-off has been removed from the main fusebox.

1. Check the condition of the spark plugs.
2. Check the ignition timing.
3. Check the flow through the choke stove pipe.
4. Check the entire induction system for air leaks.

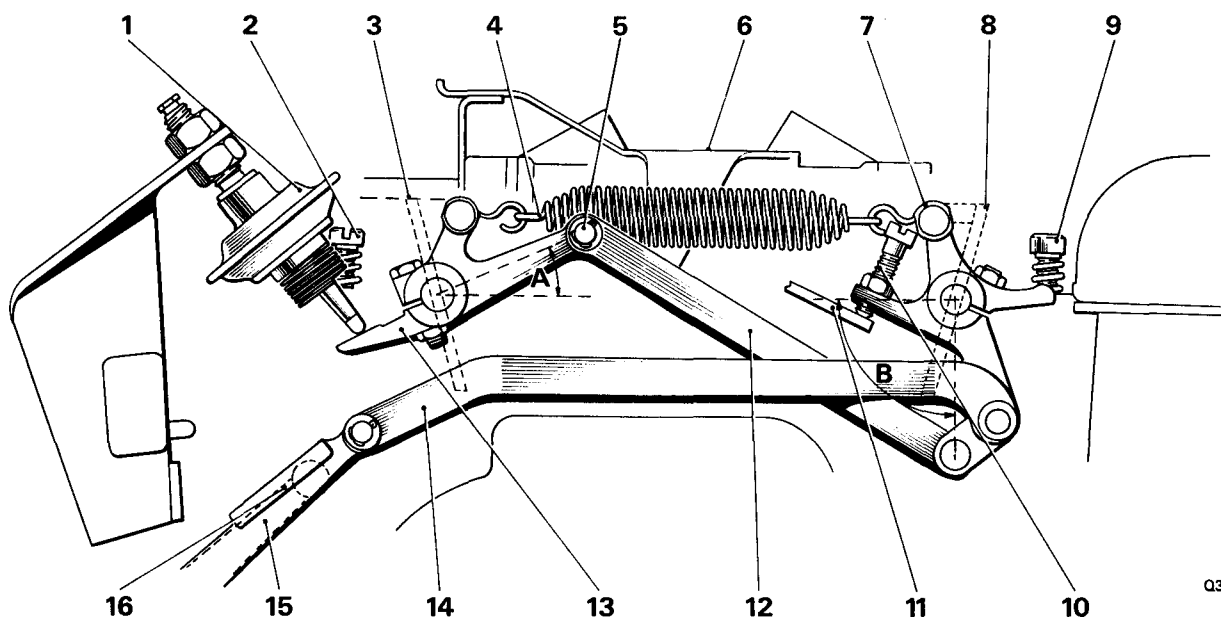

Q338

FIG. 20 CONTRA-ROTATING THROTTLE CONTROLS

- | | |
|--|---|
| A —Reference angle 22° | 8 'B' bank carburetter throttle plate |
| B —Reference angle 90° | 9 'B' bank carburetter volume screw |
| 1 Throttle damper | 10 Idle stop screw |
| 2 'A' bank carburetter volume screw | 11 Closed throttle bracket |
| 3 'A' bank carburetter throttle plate | 12 Cross link |
| 4 Throttle spring | 13 'A' bank carburetter throttle lever |
| 5 Eccentric throttle adjuster | 14 Drive link |
| 6 Throttle guard | 15 Front manifold shaft lever |
| 7 'B' bank carburetter throttle lever | 16 Rear manifold shaft lever |

5. Check the purge line flow rate.
6. Ensure that the air conditioning system is switched off.
7. Start the engine and warm up; allow to run for at least 5 minutes after the thermostat has opened.
8. Stop the engine, ensure that the choke butterfly valve is fully open and the choke 'fast-idle' off.
9. Connect an electric impulse tachometer in accordance with manufacturer's instructions.
10. Check the float chamber depression.
11. Check the exhaust gas recirculation signal strength.
12. Check the operation of the secondary exhaust gas recirculation valve and the vacuum operated micro-switch.
13. Check and set the full throttle exhaust gas recirculation cut-out micro-switch.

Tuning procedure

1. Remove the air intake hose, blank off the hot idle compensator feed drilling (see Fig. 21) and replace the hose.

2. Remove the air hoses from the check valves and fit blanks over the valves (suitable blanks may be produced from two short lengths of rubber hose with one end plugged).

Note The air injection system is inoperative when the air hoses are disconnected from the check valves. The valves must be blanked to prevent air being drawn into the exhaust port by pulsations in the exhaust system since this would affect the idle CO reading.

3. Disconnect the exhaust gas recirculation (E.G.R.) cut-out solenoid to E.G.R. valve hoses at the E.G.R. valve ends and blank off the hoses.

4. Remove the pressure tapping cap from 'A' bank carburetter float chamber to vent the float chambers to atmosphere.

5. Remove the carburetter dampers and fit a dial gauge assembly (RH 8841) in place of the damper. Ensure that both gauges read zero with the engine stopped. Start the engine and allow to idle at 600 r.p.m. noting that the piston lift shown on the dial gauge assemblies is equal (within 10%), adjust using the eccentric adjuster on the carburetter throttle linkage.

Note The average carburetter piston lift is between 0.035 in. (0.89 mm.) and 0.050 in. (1.27 mm.).

6. Ensure that the engine has run for at least 25 minutes after the thermostat has opened.

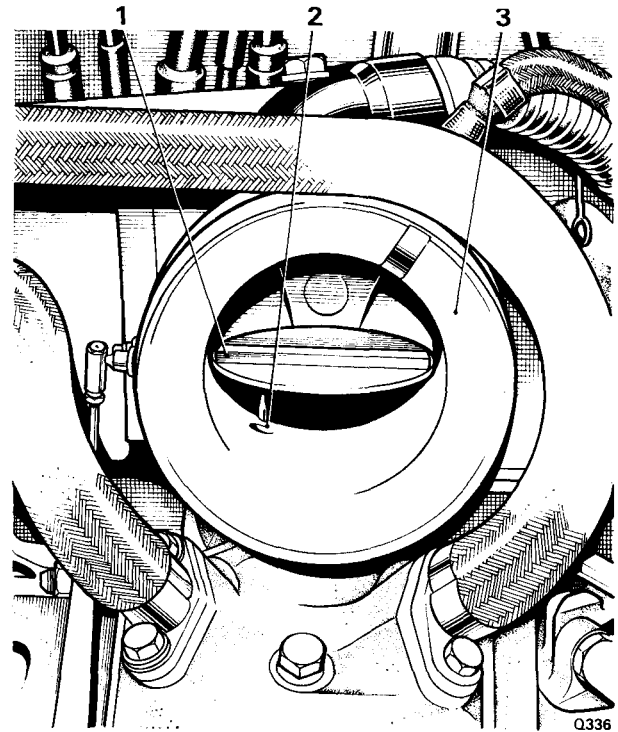

FIG. 21 HOT IDLE MIXTURE COMPENSATOR FEED

- 1 Choke butterfly
- 2 Hot idle compensator feed
- 3 Butterfly housing

7. To set 'A' bank carburetter mixture strength, remove the forward of the two blanks on the 'A' bank air manifold (see Fig. U20—Page U32); fit adapter (RH 8621) and connect to the CO meter.

8. Purge the engine at 2 000 r.p.m. in Neutral for $\frac{1}{4}$ minute, check the idle speed and reset to 600 r.p.m. using the throttle stop screw (Fig. 18, item 7).

9. Slacken the jet adjusting screw lock-nut on 'A' bank carburetter using spanner RH 8050 and set the CO meter reading to between $3\frac{3}{4}\%$ and $4\frac{1}{4}\%$ by adjusting the jet screw on 'A' bank carburetter (turning the screw clockwise richens the mixture). Tighten the lock-nut.

10. Remove the adapter RH 8621 from the air manifold and fit the blanking plug.

11. To set the mixture strength of 'B' bank carburetter, remove the rear blanking plug of the two blanking plugs on the 'A' bank air manifold (see Fig. U20—Page U32); fit adapter RH 8621 and connect to the CO meter.

12. Purge the engine at 2 000 r.p.m. in Neutral for $\frac{1}{4}$ minute, check the idle speed and reset to 600 r.p.m. using the throttle stop screw (Fig. 18, item 7).

13. Slacken the jet adjusting screw lock-nut on 'B' bank carburetter using spanner RH 8050 and set

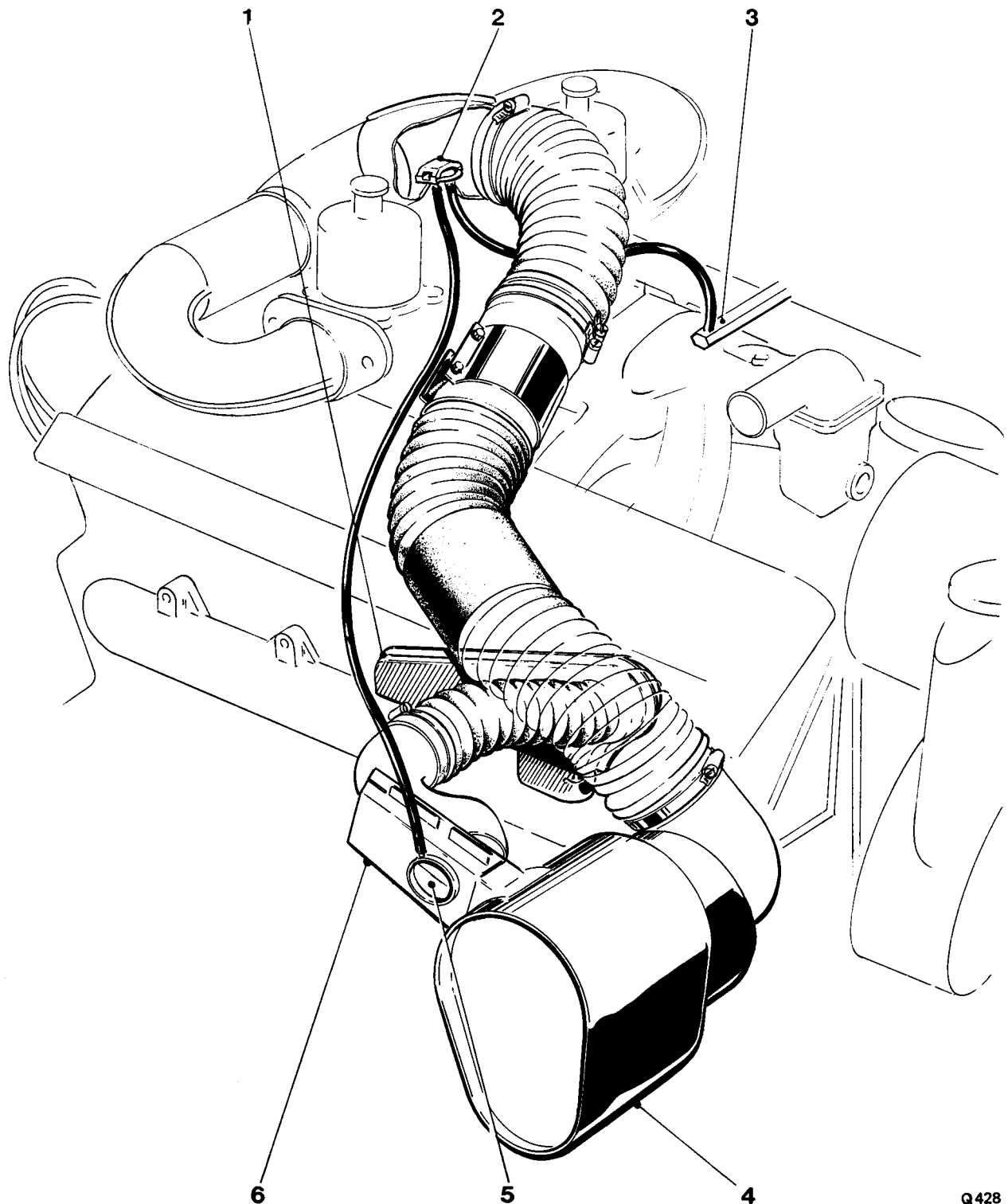

Q428

FIG. 22 TEMPERATURE CONTROLLED AIR INTAKE

- | | |
|----------------------|------------------------|
| 1 Hot air scoop | 4 Air cleaner/silencer |
| 2 Temperature sensor | 5 Air blending valve |
| 3 Vacuum manifold | 6 Cold air intake |

the CO meter reading to between $3\frac{3}{4}\%$ and $4\frac{1}{4}\%$ by adjusting the jet screw on 'B' bank carburetter (turning the screw clockwise richens the mixture). Tighten the lock-nut.

14. Remove the adapter RH 8621 from the air manifold and refit the blanking plug.

15. If setting the mixture strength involves adjusting 'B' bank carburetter jet adjusting screw by more than $\frac{3}{8}$ of a turn, the setting operations should be repeated again on 'A' bank carburetter (*Operations 7 to 9 inclusive*).

16. Check the mixture balance by raising each piston lift pin in turn. If the mixture balance is correct, the engine response for each carburetter piston lift will be identical.

If the response from each carburetter is not identical repeat Operations 6 to 16 inclusive.

17. Stop the engine and fit the probe of a suitable CO meter into the exhaust pipe in accordance with the manufacturer's instructions (a suitable CO meter is the Horiba Mexa 200).

18. Start the engine and run at idle speed until a steady CO reading is obtained (minimum time $\frac{1}{2}$ minute). The correct reading is between $3\frac{3}{4}\%$ and $4\frac{1}{4}\%$.

19. If the CO reading is not correct, slacken both jet adjusting screw lock-nuts with spanner RH 8050. Turn both jet adjusting screws by equal amounts in the same direction (up to a maximum of $\frac{1}{4}$ turn) until a CO meter reading of between $3\frac{3}{4}\%$ and $4\frac{1}{4}\%$ is obtained (turning the screws clockwise richens the mixture). Tighten the lock-nuts.

20. Fit the pressure tapping to 'A' bank carburetter float chamber, fitting a new washer if necessary. Remove the blanks from the air hoses and connect the hoses to the check valves. Remove the blanks from the E.G.R. cut-out hoses and connect the hoses to their respective E.G.R. valves.

21. Check the engine idle speed and if necessary adjust to 600 r.p.m. using the throttle stop screw.

22. Stop the engine. Remove the air intake hose and the blank from the hot idle compensator feed; fit the air intake hose.

23. Fit the gear range actuator thermal cut-out to the main fusebox.

Note The tuning operations should be carried out in the shortest possible time. If the time exceeds 3 minutes, run the engine at 2 000 r.p.m. in Neutral for $\frac{1}{4}$ minute and then resume the tuning operations. Repeat this purging operation if a further period of 3 minutes is exceeded.

After purging the system gently tap all around the neck of the carburetter suction chamber with a lightweight non-metallic object (i.e. the wooden handle of a small screwdriver), to eliminate carburetter piston hysteresis. The engine is to be run on Indolene Clear (HO) reference fuel or equivalent (Unleaded gasoline only).

Throttle damper plunger—To set

1. Move the cold start 'fast-idle' to the off position.
2. Slacken both nuts securing the throttle damper to it's bracket. Back off the nuts until they are well clear of the bracket.
3. Press the damper towards the 'A' bank throttle lever until the damper is fully compressed and the lever is just clear of the throttle stop screw.
4. Screw the lower securing nut until it is 0.025 in. (0.63 mm.) clear of the underside of the bracket. Release the damper and tighten the upper securing nut.
5. Ensure that the damper spindle is at the maximum possible radius, whilst maintaining adequate contact with the throttle lever pad. This can be achieved by adjusting the angle of the bracket.

Automatic choke stove pipe—To check

To check the stove pipe for any blockage, carry out the following procedure.

1. Start the engine and run until normal operating temperature is attained.
2. Disconnect the union at the butterfly housing and connect a flowmeter to the pipe via connector RH 8945. The flowmeter must be a rotameter type capable of measuring up to 100 cu. ft/hr. (2,83 cu. m/hr.).
3. Start the engine and run at idle speed (i.e. 600 r.p.m.); observe the flowmeter reading which should be between 50 cu. ft/hr. and 55 cu. ft/hr. (1,41 cu. m/hr. and 1,55 cu. m/hr.).
4. If the flowmeter reading is below 50 cu. ft/hr. (1,41 cu. m/hr.), stop the engine, remove the choke stove pipe and stove assembly to check for leaks.
5. If the flowmeter reading is above 55 cu. ft/hr. (1,55 cu. m/hr.) fit a new restrictor in the end of the choke bi-metal housing (*see Fig. 18*).
6. Fit the choke stove pipe and stove assembly, start the engine and again observe the flowmeter reading at idle speed.

Chapter U

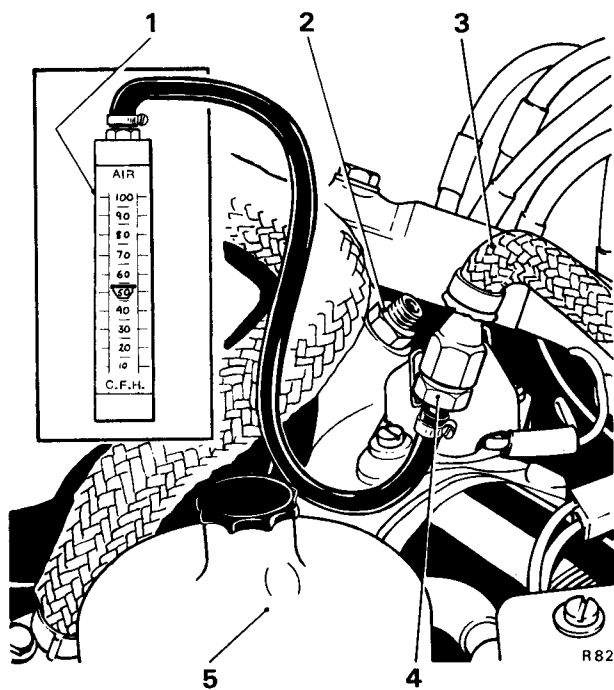

FIG. 23 CHECKING THE FLOW THROUGH THE CHOKE STOVE PIPE

- 1 Flowmeter
- 2 Choke stove pipe connection
- 3 Choke stove pipe
- 4 Adapter
- 5 'B' bank carburettor

7. Disconnect the flowmeter assembly and fit the choke stove pipe to the connection on the butterfly housing.

AUTOMATIC CHOKE—TO SET

Adjustment to kick diaphragm

Refer to Chapter K, Section K4.

Adjustment of the kick gap

Refer to Chapter K, Section K4.

Solenoid air gap

Refer to Chapter K, Section K4.

Solenoid lever spring tension

Refer to Chapter K, Section K4.

'Fast-idle' cam—To set

1. Fit the 'fast-idle' mechanism; do not tighten the 'fast-idle' lever clamping bolt.
2. Ensure that the 'fast-idle' adjustment screw is directly over the cam.
3. With the throttles closed, insert a 0.100 in. (2.54 mm.) diameter rod between the top of the 'fast-idle' cam and the boss under the 'fast-idle' adjustment screw. Tighten the clamping bolt on the 'fast-idle' lever.
4. Ensure that the throttles are closed; screw in the 'fast-idle' adjustment screw until it just makes contact with the top step of the 'fast-idle' cam.
5. Insert a 0.050 in. (1.27 mm.) diameter drill between the leading edge of the choke butterfly valve and the choke housing.
6. With the butterfly valve in this position, adjust the length of the butterfly rod so that the tip of the 'fast-idle' screw is in line with the start of the top step of the 'fast-idle' cam, (i.e. the position when the tip of the adjustment screw is about to fall from the top step to the bottom step of the cam.)
Remove the 0.050 in. (1.27 mm.) diameter drill from the choke housing.
7. With the throttles closed and the choke partly open, adjust the 'fast-idle' adjustment screw to just contact the start or bottom step of the 'fast-idle' cam, screw in a further $\frac{3}{4}$ turn and tighten the lock-nut ensuring that the adjustment screw does not move.

Thermocoil

Refer to Chapter K, Section K4.

Cold start 'fast-idle'—To set

1. Stop the engine and disconnect both solenoid to exhaust gas recirculation valve hoses at the valve ends. Blank the hoses. Disconnect the signal hose to the distributor vacuum capsule at the capsule and blank off the hose. Remove the pressure tapping cap to vent the float chambers; open the throttles and close the choke butterfly against the bi-metal coil tension by means of the butterfly link lever, release the throttles. The 'fast-idle' adjusting screw will now be resting on the high step of the 'fast-idle' cam and the throttles are in the cold start position.
2. Start the engine and check the 'fast-idle' speed. If the speed is not between 1 900 r.p.m. and 2 100 r.p.m., stop the engine, open the throttles to gain access to the adjusting screw and adjust $\frac{1}{8}$ turn for each 100 r.p.m. outside the required speed.

3. Tighten the lock-nut and check the 'fast-idle' speed. If correct open the throttles to release the 'fast-idle' cam mechanism.

4. Remove the blanks from both solenoid to the exhaust gas recirculation valve hoses and connect the hoses to their respective exhaust gas recirculation valves. Fit the pressure tapping cap to 'A' bank carburetter float chamber cover.

5. Remove the blank from the distributor advance vacuum signal hose and connect the hose to the capsule.

Float chamber depression—To check

Refer to Page U37 noting the following information.

- (i) The hose referred to in Operations 1 and 7 is now two hoses, one for each exhaust gas recirculation valve.
- (ii) The correct reading to be obtained on the manometer is 2.0 in. (5.08 cm.).
- (iii) Operation 8 should read.

8. Raise the engine speed slowly noting the manometer and tachometer readings. The maximum steady manometer reading should be obtained between 1 300 r.p.m. and 1 600 r.p.m. If the maximum depression occurs below 1 300 r.p.m. it is permissible to screw out the idle bleed screws on the carburetters by equal amounts (maximum 2.5 turns) to obtain this speed.

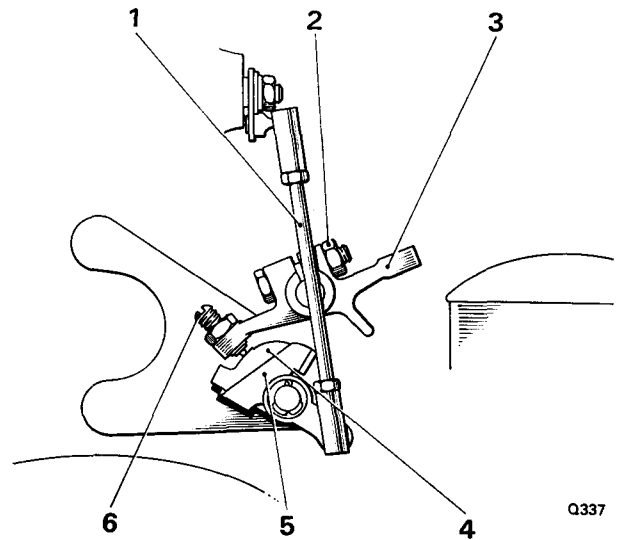

FIG. 24 'FAST-IDLE' MECHANISM

- 1 Butterfly rod
- 2 Lever clamp bolt
- 3 'Fast-idle' lever
- 4 Cam
- 5 Cam link
- 6 Adjusting screw

Exhaust gas recirculation signal strength —To check

Refer to Page U164 in this Supplement

Exhaust gas recirculation secondary valve cut-in solenoid and vacuum operated micro-switch—To check and set

Refer to Page U173 in this Supplement

Exhaust gas recirculation full throttle cut-off micro-switch—To set

Refer to Page U175 in this Supplement

IGNITION SYSTEM, DISTRIBUTOR, IGNITION COIL AND SPARKING PLUGS

Data

Ignition timing . . . 9° B.T.D.C. (Static) 15° B.T.D.C. at 1 200 r.p.m. (stroboscopic) in Neutral with the vacuum advance disconnected.
(Approach 1 200 r.p.m. from a higher speed).

Ignition control system

The ignition system utilises an Opus distributor (in which an oscillator pick-up and control unit replace the conventional contact breaker), a low inductance ignition coil and a ballast resistor. The control unit comprises an electronic oscillator, amplifier and power transistor.

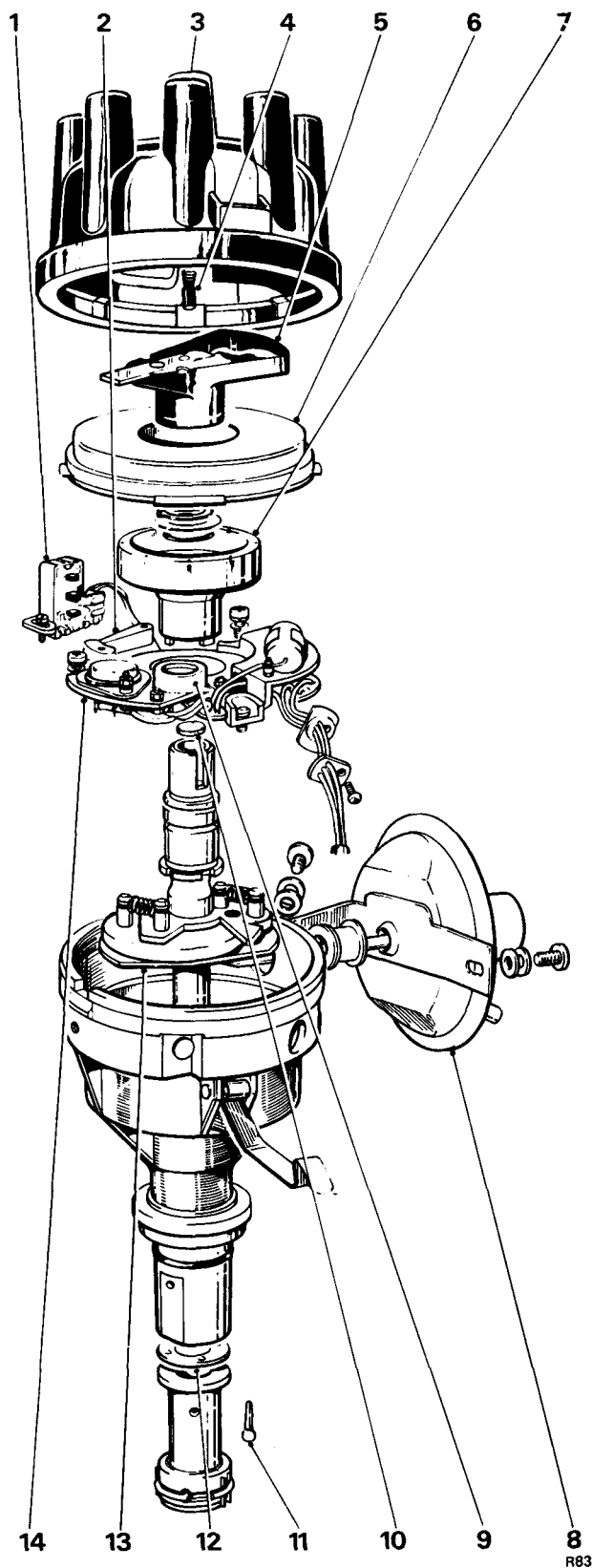

FIG. 25 EXPLODED VIEW OF DISTRIBUTOR

- 1 Pick-up module
- 2 Pick-up arm
- 3 Distributor cover/cap
- 4 High tension brush and spring
- 5 Rotor arm
- 6 Flash over shield (dust cover)
- 7 Timing rotor
- 8 Vacuum unit
- 9 Control unit
- 10 Lubrication pad
- 11 Driving dog and pin
- 12 Thrust washer
- 13 Automatic advance mechanism
- 14 Electronic module assembly

pick-up, this signal is then amplified and used to switch-off the normally conducting power transistor in the primary coil circuit thus inducing a high voltage in the secondary winding which is distributed to the sparking plugs in the normal manner.

In addition to the normal centrifugal advance mechanism the ignition distributor is fitted with a vacuum advance capsule. The E.G.R. gated orifice vacuum signal is applied to the capsule to advance the ignition timing for part throttle fuel economy during open road cruising. The vacuum signal is inhibited by a solenoid valve until a predetermined coolant temperature is reached.

This ignition control system provides increased accuracy of timing and increased service life before maintenance is required.

Ignition—To time (using a stroboscope)

The ignition is timed on A1 cylinder which is located at the front left-hand side of the engine (viewed from the front of the car).

Note If the ignition timing is to be set, ensure that the sparking plugs are in good condition before running the engine; if they require cleaning or renewal the sparking plugs gap should be set to 0.035 in. (0.9 mm.).

1. To check the ignition timing commence by running the engine until normal operating temperature is attained and the choke 'fast-idle' is in the off position. Switch off the engine.

2. Connect a stroboscope and a tachometer to the engine as described in the instructions supplied with the respective equipment. Disconnect the feed hose at the vacuum advance capsule; blank off the feed hose.

3. Start the engine and adjust the throttle stop screw to give an idle speed of 1 200 r.p.m. When setting the engine idle speed reduce from a higher speed to 1 200 r.p.m.

4. Direct the flashing light of the stroboscope onto the crankshaft damper timing marks and timing

A drum with eight ferrite rods (one per cylinder) moulded into the outer edge is mounted onto the distributor drive-shaft. As the drum rotates a voltage is created each time a ferrite rod passes the oscillator

pointer; the pointer is positioned on the right-hand side of the crankshaft damper when viewed from the front of the engine.

5. If the timing pointer does not coincide with the 15° B.T.D.C. mark on the crankshaft damper adjust the ignition timing as follows.

6. Release the clamp screw on the distributor and rotate the head of the distributor in the appropriate direction until the correct timing is obtained. Clockwise rotation of the distributor head advances the ignition and conversely anti-clockwise rotation retards the ignition. After adjustment has been carried out tighten the clamp screw and again check to ensure that the timing has not altered whilst tightening the clamp screw.

7. Set the engine idle speed to 600 r.p.m.

8. Direct the flashing light of the stroboscope onto the crankshaft damper timing marks and timing pointer. Check that the ignition timing is approximately 9° B.T.D.C.

9. Stop the engine.

10. Disconnect the hose from the vacuum manifold to the purge line restrictor at the restrictor (see Fig. 5). Connect a suitable length of hose between this hose and the connection on the distributor vacuum capsule.

11. Start the engine and set the idle speed to 600 r.p.m.

12. Direct the flashing light of the stroboscope onto the crankshaft damper timing marks and timing pointer. Check that the ignition timing has advanced to approximately 19° B.T.D.C. If the ignition timing has not advanced, the distributor assembly is faulty.

13. Stop the engine.

14. Fit all hoses to their correct connections.

15. Start the engine and set the idle speed to 600 r.p.m.

16. Stop the engine and remove all the test equipment.

Setting the engine idle speed

Ensure that the engine is at normal operating temperature and that the choke 'fast-idle' is in the off position.

The air conditioning system must be switched off and a tachometer connected to the engine in accordance with the manufacturer's instructions.

1. Stop the engine, remove the air intake hose and blank off the hot idle compensator feed drilling (see Fig. 21); replace the air intake hose.

2. Start the engine and, if necessary, adjust the engine idle speed to 600 r.p.m. using the throttle stop screw; tighten the lock-nut.

3. Stop the engine and remove the air intake hose. Remove the blank from the hot idle compensator feed drilling and detach the tachometer and stroboscopic timing equipment (if fitted). Fit the air intake hose.

Sparking plugs

The sparking plugs approved for this car are Champion RN. 14.Y. Before fitting the plugs, set the gaps with the aid of a feeler gauge to 0.035 in. (0.9 mm.) and lightly smear the threads with 'Graphogen' grease.

LUBRICATION AND MAINTENANCE

The 'Essential' maintenance which is listed in the following schedules is the minimum servicing which must be carried out at the appropriate distance/time intervals, in order to comply with the Rolls-Royce Motors Limited* warranty and the U.S. Federal and California Emission Regulations.

The 'Preventive' maintenance listed, is aimed at securing the maximum life and efficiency for the vehicle and will be carried out on request.

*In the U.S.A. this warranty is given by Rolls-Royce Motors Inc.

ESSENTIAL MAINTENANCE INITIAL SERVICE

This service will be carried out by the Dealer after the first 3 000 miles (5 000 km.) or 3 months whichever is the earlier.

Items marked * will be carried out free of charge.

INITIAL 3 000 MILES (5 000 km.) OR 3 MONTHS SERVICE WHICHEVER IS THE EARLIER

*Air injection pump

Check belt tension and reset if necessary.

*Automatic choke

Check the flow through the choke stove pipe and check for correct operation.

*Carburettors

Check oil level in air valve dampers and if necessary top-up to correct level. Check tightness of float chamber covers. Check float chamber depression. Check and if necessary reset the idle speed. Check and if necessary reset the choke 'fast-idle' speed.

Chapter U

Engine

Change engine oil.

***Fuel evaporation emission control system**

Check the purge rate; this should be between 50 cu. ft. per hr. and 70 cu. ft. per hr. (1,41 cu. m. per hr. and 1,98 cu. m. per hr.) at 600 r.p.m. in Neutral. Pressure test the fuel tank and evaporation loss line and if necessary rectify any leaks.

***Ignition system**

Check ignition timing using stroboscope and adjust if necessary; the ignition timing should be 15° B.T.D.C. with the engine running at 1200 r.p.m., the vacuum capsule disconnected and the feed hose blanked off.

Belt tension

Check the tension of all driving belts.

Engine cooling system

Tighten wormdrive clips of all coolant hoses.

Torque converter transmission

Check fluid level and top-up if necessary.

When checking the fluid level, avoid contact with the exhaust gas recirculation valves, heat shield and associated pipes as these components will be **hot**.

EVERY 3 000 MILES (5 000 km.) OR 3 MONTHS WHICHEVER IS THE EARLIER

If the car is used for constant stop/start operation change the engine oil.

EVERY 6 000 MILES (10 000 km.) OR 6 MONTHS WHICHEVER IS THE EARLIER

Engine

Change engine oil and renew oil filter element.

Battery

Check the level of the electrolyte in the battery; if necessary top-up with distilled water.

Belt tension

Check the tension of all driving belts.

Brakes

Inspect footbrake and parking brake pad linings. When changing footbrake pads examine condition of dust excluders on calipers. Manually adjust the parking brake pads. Inspect pipes and connections, rectify if necessary.

Fluid levels

Check all fluid levels.

Torque converter transmission

Check fluid level and top-up if necessary.

When checking the fluid level, avoid contact with the exhaust gas recirculation valves, heat shield and associated pipes as these components will be **hot**.

EVERY 12 500 MILES (20 000 km.) OR 12 MONTHS SERVICE WHICHEVER IS THE EARLIER

Air injection pump

Check tension of pump pulley driving belt.

Air silencer

Fit a new paper filter element.

Carburettors

Top-up oil level in air valve dampers. Check tightness of float chamber covers. Check float chamber depression. Check and if necessary reset the idle speed. Check and if necessary, reset the choke 'fast-idle' speed.

Crankcase emission control system

Remove and clean gauze flame traps in the crankcase breather tube. Clean the adapter in the choke butterfly housing.

Engine

Change engine oil and renew oil filter element.

Fuel evaporation emission control system

Check the condition of the pipes and connections.

Ignition system

Fit new sparking plugs ensuring that the gaps are set to 0.035 in. (0,9 mm.).

Lubricate distributor spindle (shaft bearings) and automatic advance mechanism with engine oil.

Check the ignition timing using a stroboscope and adjust if necessary; the ignition timing should be 15° B.T.D.C. with the engine running at 1 200 r.p.m., the vacuum capsule disconnected and the feed hose blanked off.

Battery

Check the level of the electrolyte in the battery; if necessary top-up with distilled water.

Belt tension

Check the tension of all driving belts.

Brakes

Inspect footbrake and parking brake pad linings. When changing footbrake pads examine condition of dust excluders on calipers. Manually adjust parking brake pads. Inspect pipes and connections, rectify if necessary.

Final drive unit

Check oil level and top-up if necessary.

Fluid levels

Check all fluid levels.

Front suspension

The front suspension ball joints are sealed for life and no maintenance is required until renewal is necessary or the ball joint rubber covers are damaged. Inspect the rubber covers on the front suspension ball joints; if the covers are found to be damaged new joints and covers should be fitted.

Steering ball joints

Lubricate the six grease nipples. Inspect the rubber covers on the ball joints; if the covers are found to be damaged the joints should be dismantled and new parts fitted as necessary.

Torque converter transmission

Renew transmission fluid.

When checking the fluid level, avoid contact with the exhaust gas recirculation valves, heat shield and associated pipes as these components will be **hot**.

EVERY 18 500 MILES (30 000 km.) OR 18 MONTHS SERVICE WHICHEVER IS THE EARLIER

Engine

Change engine oil and renew oil filter element.

Battery

Check the level of the electrolyte in the battery; if necessary top-up with distilled water.

Belt tension

Check the tension of all driving belts.

Brakes

Inspect footbrake and parking brake pad linings. When changing footbrake pads examine condition of dust excluders on calipers. Manually adjust the parking brake pads. Inspect pipes and connections, rectify if necessary.

Fluid levels

Check all fluid levels.

Torque converter transmission

Check fluid level and top-up if necessary.

When checking the fluid level, avoid contact with the exhaust gas recirculation valves, heat shield and associated pipes as these components will be **hot**.

EVERY 25 000 MILES (40 000 km.) OR 2 YEARS SERVICE WHICHEVER IS THE EARLIER

Air injection pump

Check tension of pump pulley driving belt.

Air injection system

Check air injection system for leaks and correct functioning. Renew any defective items.

Air silencer

Fit a new paper filter element.

Automatic choke

Check the air flow through the choke stove pipe and check the system for correct functioning.

Carburettors

Clean air valves. Remove inlet unions from the float chamber covers and fit new paper filter elements. Top-up oil level in air valve dampers. Check tightness of float chamber covers. Check float chamber depression. Check and if necessary, reset the idle speed. Check and if necessary, reset choke 'fast-idle' speed.

Carburetter mixture weakening device

Renew air filter element for the carburetter mixture weakening device.

Chapter U

Crankcase emission control system

Remove and clean gauze flame traps in crankcase breather tube. Clean the adapter in choke butterfly housing.

Engine

Change engine oil and renew oil filter element.

Engine cooling system

Fit a new engine coolant thermostat and heater tap feed hose. Check the condition of all coolant hoses: fit new hoses as necessary.

Fuel evaporation emission control system

Renew the foam filter element in the evaporation loss control canister. Check the purge rate; this should be between 50 cu. ft. per hr. and 70 cu. ft per hr. (1,41 cu. m. per hr. and 1,98 cu. m. per hr.) at 600 r.p.m. in Neutral. Renew the purge line filter if necessary.

Ignition system

Fit new sparking plugs ensuring that the gaps are set to 0.035 in. (0,9 mm.).

Lubricate distributor spindle (shaft bearings) and automatic advance mechanism with engine oil.

Check the ignition timing using a stroboscope and adjust if necessary; the ignition timing should be 15° B.T.D.C. with the engine running at 1 200 r.p.m., the vacuum capsule disconnected and the feed hose blanked off. Check the vacuum advance mechanism.

Battery

Check the level of the electrolyte in the battery; if necessary top-up with distilled water.

Belt tension

Check the tension of all driving belts.

Brakes

Inspect footbrake and parking brake pad linings. When changing footbrake pads examine condition of dust excluders on calipers. Manually adjust parking brake pads. Inspect pipes and connections: rectify if necessary.

Final drive unit

Change oil.

Fluid levels

Check all fluid levels.

Front suspension

The front suspension ball joints are sealed for life and no maintenance is required until renewal is necessary or the ball joint rubber covers are damaged. Inspect the rubber covers on the front suspension ball joints: if the covers are found to be damaged new joints and covers should be fitted.

Fuel pumps

Remove the fuel pumps and check for pumping efficiency, fit new pumps if necessary.

Hydraulic systems

Completely drain the fluid from the hydraulic circuits. Thoroughly clean the brake fluid reservoirs and sight glasses, ensure that no foreign matter enters the systems. Fill the hydraulic systems with new approved fluid. Bleed the brakes and height control systems.

Rear wheel drive-shafts

Lubricate the rear wheel drive-shaft outer universal couplings with approved grease.

Steering ball joints

Lubricate the six grease nipples. Inspect the rubber covers on the ball joints; if the covers are found to be damaged the joints should be dismantled and new parts fitted as necessary.

Torque converter transmission

Change transmission fluid.

Fit a new intake strainer.

When checking the fluid level, avoid contact with the exhaust gas recirculation valves, heat shield and associated pipes as these components will be hot.

SERVICING AFTER 25 000 MILES (40 000 km.) OR 2 YEARS WHICHEVER IS THE EARLIER

After 25 000 miles (40 000 km.) or 2 years, servicing is still due at the following intervals.

31 000 MILES (50 000 km.) OR 2½ YEARS WHICHEVER IS THE EARLIER

Carry out the 6 000 miles (10 000 km.) service.

**37 500 MILES (62 000 km.) OR
3 YEARS WHICHEVER IS THE
EARLIER**

Carry out the 12 500 miles (20 000 km.) service.

**43 500 MILES (70 000 km.) OR
3½ YEARS WHICHEVER IS
THE EARLIER**

Carry out the 6 000 miles (10 000 km.) service.

**50 000 MILES (80 000 km.) OR
4 YEARS WHICHEVER IS
THE EARLIER**

Carry out the 25 000 miles (40 000 km.) service and in addition the following operations.

Exhaust gas recirculation system

Remove and clean the exhaust gas recirculation valves and feed pipes. Clean the orifices in the carburetter 'Tee' piece. Check the exhaust gas recirculation valves for correct operation.

PREVENTIVE MAINTENANCE

INITIAL SERVICE

This service should be carried out by the Dealer after the first 3 000 miles (5 000 km.) or 3 months whichever is earlier.

Steering pump

Check the oil level in the reservoir; top-up if necessary.

Test

Road test the car for satisfactory performance.

**EVERY 6 000 MILES (10 000 km.) OR
6 MONTHS WHICHEVER IS
THE EARLIER**

Carburetters

Check the oil level in the air valve dampers and top-up if necessary.

Control linkages

Apply a few drops of engine oil to the accelerator linkage and to the gear range selector controls adjacent to the transmission casing.

Electrical system

Check all interior lamps, exterior lamps, instruments warning lamps and devices for correct operation: rectify as necessary.

Parking brake linkage

Lubricate the pivot pins and pulleys in the parking brake system with approved grease.

Tyres

Check the tread depth of all tyres, inspect all tyres for signs of damage. Check all tyre pressures when cold, adjust if necessary.

Note Include the spare tyre.

Test

Road test the car for satisfactory performance.

**EVERY 12 500 MILES (20 000 km.) OR
12 MONTHS WHICHEVER IS
THE EARLIER**

Control linkage

Apply a few drops of engine oil to the accelerator linkage and to the gear range selector controls adjacent to the transmission casing.

Electrical system

Check all interior lamps, exterior lamps, instruments, warning lamps and devices for correct operation: rectify as necessary.

Parking brake linkage

Lubricate the pivot pins and pulleys in the parking brake system with approved grease.

Spare wheel

Lubricate the spare wheel lowering bolt and mechanism.

Tyres

Check the tread depth of all the tyres, inspect all tyres for signs of damage. Check all tyre pressures when cold, adjust if necessary.

Note Include the spare tyre.

Test

Road test the car for satisfactory performance.

Chapter U

EVERY 18 500 MILES (30 000 km.) OR 18 MONTHS WHICHEVER IS THE EARLIER

Carburettors

Check the oil level in the air valve dampers and top-up if necessary.

Control linkages

Apply a few drops of engine oil to the accelerator linkage and to the gear range selector controls adjacent to the transmission casing.

Electrical system

Check all interior lamps, exterior lamps, instruments, warning lamps and devices for correct operation; rectify as necessary.

Parking brake linkage

Lubricate the pivot pins and pulleys in the parking brake system with approved grease.

Tyres

Check the tread depth of all tyres, inspect all tyres for signs of damage. Check all tyre pressures when cold, adjust if necessary.

Note Include the spare tyre.

Test

Road test the car for satisfactory performance.

EVERY 25 000 MILES (40 000 km.) OR 2 YEARS WHICHEVER IS THE EARLIER

Control linkage

Apply a few drops of engine oil to the accelerator linkage and to the gear range selector controls adjacent to the transmission casing.

Electrical system

Check all interior lamps, exterior lamps, instruments, warning lamps and devices for correct operation; rectify as necessary.

Fuel filter

Renew the main line filter element and clean the filter bowl.

Fuel tank

Slacken the drain plug one or two turns and allow any accumulated water to drain away. Tighten the drain plug.

Height control mechanism

Disconnect the control valve linkage ball joints. Clean, grease and refit the ball joints.

Parking brake linkage

Lubricate the pivot pins and pulleys in the parking brake system with approved grease.

Spare wheel

Lubricate the spare wheel lowering bolt and mechanism.

Tyres

Check the tread depth of all the tyres, inspect all tyres for signs of damage. Check all tyre pressures when cold, adjust if necessary.

Note Include the spare tyre.

Test

Road test the car for satisfactory performance.

SERVICING AFTER 25 000 MILES (40 000 km.) OR 2 YEARS WHICHEVER IS THE EARLIER

After 25 000 miles (40 000 km.) or 2 years, servicing is still due at the following intervals.

31 000 MILES (50 000 km.) OR 2½ YEARS WHICHEVER IS THE EARLIER

Carry out the 6 000 miles (10 000 km.) service.

37 500 MILES (60 000 km.) OR 3 YEARS WHICHEVER IS THE EARLIER

Carry out the 12 500 miles (20 000 km.) service

**43 500 MILES (70 000 km.) OR
3½ YEARS WHICHEVER IS
THE EARLIER**

Carry out the 6 000 miles (10 000 km.) service.

**50 000 MILES (80 000 km.) OR
4 YEARS WHICHEVER IS
THE EARLIER**

Carry out the 25 000 miles (40 000 km.) service.

**SEASONAL SCHEDULES
EVERY 12 MONTHS**

Engine cooling system

Drain the coolant from the radiator and the engine crankcase. Clean any debris from the surfaces of the refrigeration condenser and radiator matrices by reverse flushing with a hose. This should be carried out just prior to the Autumn. Fill the system with the correct anti-freeze mixture (*refer to Chapter L—Engine Cooling System of this Workshop Manual T.S.D. 2476 and the latest Service Bulletin*).

Air conditioning system

Ensure that the foam filter element fitted to the scuttle intake grille is free from obstruction. On Long Wheelbase cars fitted with a centre division, check that the foam filter element fitted to the intake grille in the rear decking panel is free from obstruction.

Check the refrigeration system for correct operation, rectify as necessary. Any work must be carried out by an experienced engineer.

Body

Check that the body drain holes are free from foreign matter.

EVERY 2 YEARS

In addition to the 12 monthly schedule, carry out the following.

Engine cooling system

Drain the coolant from the radiator and engine crankcase. Thoroughly reverse flush the coolant passages with a continuous flow of water. Change the coolant hoses where necessary. Fill the system with the correct anti-freeze mixture.

SERVICE RECOMMENDATIONS

50 000 Miles (80 000 km.)

Brake and hydraulic system

At this mileage and under normal motoring conditions it is recommended that the following servicing is carried out.

Renew the front and rear accumulator to frame connector block hoses.

Examine the sub-frame to brake caliper hoses for chafing or surface cracking; renew if necessary.

Completely drain the fluid from the hydraulic circuits. Thoroughly clean the brake fluid reservoirs and sight glasses, ensuring that no foreign matter is allowed to enter during the operation.

Fill the hydraulic system with Castrol RR 363 Brake Fluid. This fluid exceeds specification S.A.E. J 1703b in many respects and complies with D.O.T. 3 grade of FMVSS 116. Bleed the braking systems and automatic height control system.

100 000 Miles (160 000 km.)

Brake and hydraulic system

At this mileage and under normal motoring conditions it is recommended that the following servicing is carried out.

Renew all the flexible hoses to the braking systems and the automatic height control system. Fit new seals to the disc brake calipers and the deceleration conscious pressure limiting valve.

Completely drain the fluid from the hydraulic circuits. Thoroughly clean the brake fluid reservoirs and sight glasses, ensuring that no foreign matter is allowed to enter during the operation.

Fill the hydraulic system with Castrol RR 363 Brake Fluid. This fluid exceeds specification S.A.E. J 1703b in many respects and complies with D.O.T. 3 grade of FMVSS 116. Bleed the braking systems and automatic height control system.

Fuel system

Fit a new convoluted rubber hose between the fuel filler head and fuel tank assembly. Examine all flexible fuel pipes and renew any which show signs of deterioration.

SPECIAL PRECAUTIONS

Should the car be used in very cold temperatures, drain the engine sump when thoroughly warm and also drain the carburettor air valve dampers. The engine sump and carburettor air valve dampers should then be filled with oil having the following viscosity.

For constant temperatures of between 0°C. and -23°C. (32°F. and -10°F.), use a 10W/30 grade oil.

For constant temperatures of -23°C. (-10°F.) and below, use a 5W/20 grade oil.

Chapter U

FAULT DIAGNOSIS

SYMPTOMS	POSSIBLE CAUSE
<p>1. Engine will not start. (Starter motor operating).</p>	<p>1. (a) Ignition circuit broken. (b) Failed anti 'run-on' solenoid or failure of electrical supply circuit. (c) Ignition system faulty. (d) Damaged or contaminated ignition high-tension circuit. (e) Fault in fuel feed line or fouled float chamber filters. (f) Faulty choke bi-metal coil. (g) Choke solenoid inoperative. (h) Faulty choke 'fast-idle' mechanism. (i) Air leak into induction system. (j) Faulty hot idle mixture compensator. (k) Weakening device filter blocked or blockage in rubber connecting hoses. (l) Faulty weakener cut-off solenoid or failure of electrical supply circuit. (m) Faulty weakening device control switch or failure of electrical supply circuit. (n) Dislodged venturi in weakener device. (o) Flooding of carburetter float chamber or jet. (p) Fouled carburetter float chamber or jet. (q) Exhaust gas recirculation valve(s) failed. (r) Faulty exhaust gas recirculation secondary valve control switch or failure of electrical supply circuit. (s) Failed secondary exhaust gas recirculation valve cut-out solenoid or electrical supply circuit.</p>
<p>2. Engine idles very roughly.</p>	<p>2. (a) Ignition system faulty. (b) Fouled sparking plugs. (c) Damaged or contaminated ignition high-tension circuit. (d) Air leak into induction system. (e) Faulty hot idle compensator. (f) Weakening device filter blocked or blockage in rubber connecting hoses. (g) Dislodged venturi in weakener device. (h) Badly worn or damaged carburetter control linkage. (i) Flooding of carburetter float chamber or jet. (j) Sticking carburetter piston. (k) Fouled carburetter float chamber or jet. (l) Air leak into exhaust gas recirculation vacuum control circuit. (m) Exhaust gas recirculation valve(s) failed. (n) Faulty exhaust gas recirculation secondary valve control switch or failure of electrical supply circuit. (o) Failed secondary exhaust gas recirculation valve cut-out solenoid or electrical supply circuit. (p) Faulty air diverter valve. (q) Incorrect operation of temperature controlled air intake system.</p>
<p>3. Engine stalls.</p>	<p>3. (a) Ignition circuit broken. (b) Failed anti 'run-on' solenoid or failure of electrical supply circuit. (c) Ignition system faulty. (d) Damaged or contaminated ignition high-tension circuit. (e) Fault in fuel feed line or fouled float chamber filters. (f) Air leak into induction system. (g) Faulty hot idle mixture compensator. (h) Weakening device filter blocked or blockage in rubber connecting hoses. (i) Dislodged venturi in weakening device. (j) Badly worn or damaged carburetter control linkage. (k) Flooding of carburetter float chamber or jet. (l) Sticking carburetter piston. (m) Fouled carburetter float chamber or jet. (n) Air leak into exhaust gas recirculation vacuum control circuit. (o) Exhaust gas recirculation valve(s) failed. (p) Faulty exhaust gas recirculation secondary valve control switch or failure of electrical supply circuit. (q) Failed secondary exhaust gas recirculation valve cut-out solenoid or electrical supply circuit. (r) Faulty air diverter valve.</p>

SYMPTOMS	POSSIBLE CAUSE
<p>4. (i) Engine shows signs of power loss, evident at high speeds and loading. (ii) Engine misfires particularly on hard acceleration from low speed.</p>	<p>4. (a) Ignition system faulty. (b) Fouled sparking plugs. (c) Damaged or contaminated ignition high-tension circuit. (d) Fault in fuel feed line or fouled float chamber filters. (e) Choke system operation incorrect. (f) Sticking carburetter piston. (g) Fouled carburetter float chamber or jet. (h) Faulty exhaust gas recirculation full throttle cut-out switch or failure of electrical supply circuit. (i) Exhaust gas recirculation valve(s) failed. (j) Failed primary exhaust gas recirculation valve cut-out solenoid or electrical supply circuit. (k) Failed secondary exhaust gas recirculation valve cut-out solenoid or electrical supply circuit.</p>
<p>5. Engine hesitates or misfires under light load.</p>	<p>5. (a) Failed anti 'run-on' solenoid or failure of electrical supply circuit. (b) Ignition system faulty. (c) Fouled sparking plugs. (d) Damaged or contaminated ignition high-tension circuit. (e) Fault in fuel feed line or fouled float chamber filters. (f) Air leak into induction system. (g) Faulty hot idle mixture compensator. (h) Weakening device filter blocked or blockage in rubber connecting hoses. (i) Dislodged venturi in weakening device. (j) Flooding of carburetter float chamber or jet. (k) Sticking carburetter piston. (l) Fouled carburetter float chamber or jet. (m) Incorrect purge flow rate. (n) Exhaust gas recirculation valve(s) failed. (o) Faulty exhaust gas recirculation secondary valve control switch or failure of electrical circuit. (p) Failed secondary exhaust gas recirculation valve cut-out solenoid or electrical supply circuit. (q) Faulty air diverter valve. (r) Incorrect operation of temperature controlled air intake system.</p>
<p>6. Increase in fuel consumption.</p>	<p>6. (a) Ignition system faulty. (b) Faulty choke bi-metal coil. (c) Choke system operation incorrect. (d) Air leak into induction system. (e) Faulty hot idle mixture compensator. (f) Weakening device filter blocked or blockage in rubber connecting hoses. (g) Faulty weakener cut-off solenoid or failure of electrical supply circuit. (h) Faulty weakening device control switch or failure of electrical supply circuit. (i) Air leaks in mixture weakening system. (j) Flooding of carburetter float chamber or jet. (k) Sticking carburetter piston. (l) Incorrect purge flow rate. (m) Exhaust gas recirculation valve(s) failed. (n) Faulty exhaust gas recirculation secondary valve control switch or failure of electrical supply circuit. (o) Failed secondary exhaust gas recirculation valve cut-out solenoid or electrical supply circuit. (p) Faulty air diverter valve.</p>
<p>7. Decrease in fuel consumption.</p>	<p>7. (a) Air leaks in mixture weakening system. (b) Incorrect purge flow rate. (c) Faulty exhaust gas recirculation temperature control switch or failure of electrical supply circuit. (d) Air leak into exhaust gas recirculation vacuum control circuit. (e) Exhaust gas recirculation valve(s) failed. (f) Faulty exhaust gas recirculation secondary valve control switch or failure of electrical supply circuit.</p>

Chapter U

SYMPTOMS	POSSIBLE CAUSE
8. Engine 'backfires' on overrun.	8. (a) Ignition system faulty. (b) Air leak into induction system. (c) Exhaust gas recirculation valve(s) failed. (d) Failed secondary exhaust gas recirculation valve cut-out solenoid or electrical supply circuit.
9. Sudden increase in engine idle speed.	9. (a) Faulty choke 'fast-idle' mechanism. (b) Failed carburetter overrun valve.
10. Excessive noise from air injection pump or system.	10. (a) Faulty air diverter valve. (b) Faulty or damaged air injection pump.

WORKSHOP TOOLS

Tool Number Description

RH 8050 Spanner—Carburetter Jet Screw

RH 8087 Spanner—Weakener Cut-off Valve

RH 8089 Jet Centring Tool

RH 8090 Pliers—Wire Hose Clips

RH 8383 Positioning Tool—Throttle Spindle Seal

RH 8621 Adapter—Air Manifold to CO Meter

RH 8800 Vacuum Pump—Hand Operated

RH 8841 Dial Gauge—Carburetter Piston Lift

RH 8880 Setting Jig—Throttle Levers

RH 8945 Connector—Choke Stove Pipe

U198

Chapter U

Section U10

SUPPLEMENTS

No. 7 Japan 1976

Workshop personnel should refer to Chapter U (Part 2) and the Supplements Nos. 5 and 7 for servicing information applicable to 1976 model year cars.

Rolls-Royce Silver Shadow and Bentley T Series motor cars and Rolls-Royce and Bentley Corniche motor cars destined for Japan and built to the 1976 specification, have the following changes from the previous year's specification.

Changes from the 1975 Specification to the 1976 Specification.

1. Single exhaust system with a catalytic converter replacing the front silencer.
2. Heatshields for underside insulation above the catalytic converter.
3. New exhaust downtake pipe to match up with the catalytic converter.

4. Label for 'unleaded fuel' requirement fitted to the inner flap of the fuel filler compartment.
5. Unleaded gasoline only label fitted either in or adjacent to the fuel gauge on the fascia.
6. Sensors fitted to the catalytic converter and body floor to activate a warning buzzer if overheating occurs.
7. Metal temperature switch fitted to 'A' bank cylinder head.
8. Additional electrically operated booster fan fitted between the radiator grille and refrigeration matrix.
9. Fuel cooler fitted adjacent to the refrigeration compressor
10. Positions of the fuel filter and fuel pump are reversed.
11. Thermostat outlet elbow with two lock-out switches fitted.
12. Radiator grille with modified vanes to accommodate booster fan mentioned in item 8.
13. Galvanised mesh heatshields beneath the exhaust system.
14. Fuel integrity system fitted to fuel tank.

Chapter U

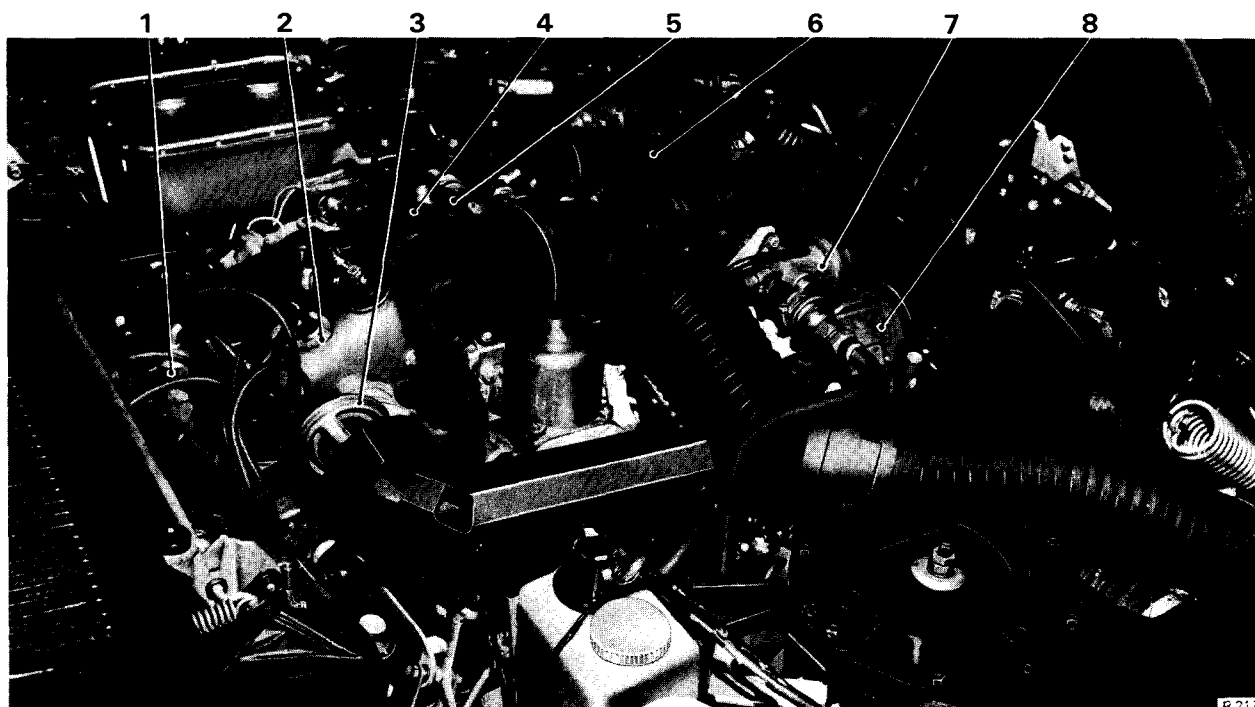

FIG. 1 VIEW INSIDE ENGINE COMPARTMENT (From Right-hand Side of Car)

- | | |
|--|------------------------|
| 1 Fuel receiver and float chamber vent valve | 5 'B' bank carburetter |
| 2 Weakener system cut-off switch | 6 Fuel cooler |
| 3 E.G.R. valve | 7 Air diverter valve |
| 4 E.G.R. distribution pipes | 8 Air pump |

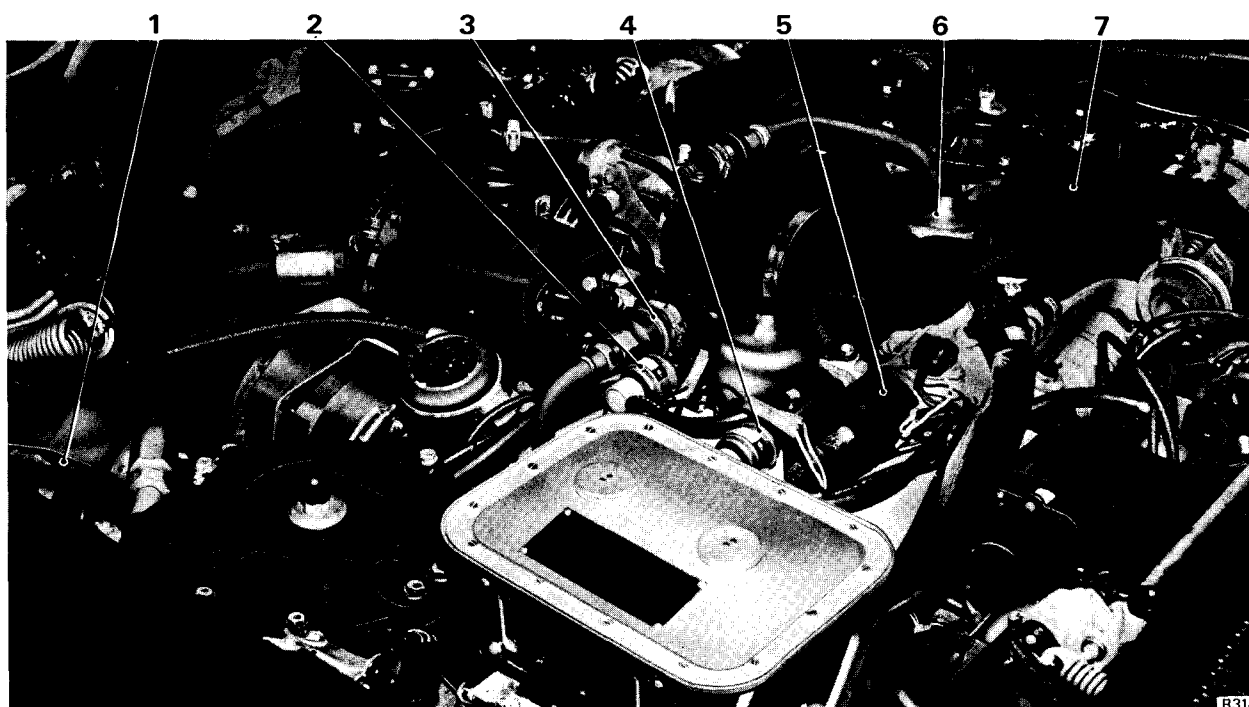

FIG. 2 VIEW INSIDE ENGINE COMPARTMENT (From Left-hand Side of Car)

- | | |
|---------------------------|-----------------------------|
| 1 Weakener filter | 5 Choke thermo-coil housing |
| 2 Anti 'run-on' solenoid | 6 'A' bank carburetter |
| 3 Check valve | 7 E.G.R. cooler |
| 4 E.G.R. cut-out solenoid | |

EXHAUST EMISSION CONTROL SYSTEM

AIR INJECTION SYSTEM

As 1975 Specification—see Supplement No. 5, except for the following.

The air diverter valve is not serviceable. If the operation of the component is suspect, the following checks should be carried out before it is replaced.

1. Ensure that the handbrake/parking brake is firmly applied and that the vehicle is in Park.
2. Start and run the engine at 2 000 r.p.m.
3. Ensure that **air does not escape** from the air diverter valve exhaust ports situated around the body of the air diverter valve.

If air escapes from the exhaust ports the air diverter valve assembly is faulty due to either a failed relief valve or a seized shuttle and must be replaced with a new unit.

4. Release the throttle linkage sharply so that the engine speed rapidly falls from 2 000 r.p.m., ensure that **air escapes** from the air diverter valve exhaust ports for a short period of time.

If air does not escape from the exhaust ports of the air diverter valve during Operation 4 check the following.

- (a) The condition of the hose from the air diverter valve to the vacuum manifold.
- (b) The condition of any hose connected to the vacuum manifold.
- (c) Repeat Operation 4.

If air still does not escape during Operation 4 the air diverter valve assembly is faulty due to either a diaphragm or timing valve failure and must be replaced.

After fitting a new air diverter valve, ensure that the component operates satisfactorily.

5. Allow the engine to idle at 600 r.p.m. Ensure that **air does not escape** from the air diverter valve exhaust ports.

EXHAUST GAS RECIRCULATION SYSTEM

As 1975 Specification—see Supplement No. 5 except for Figure 4 which provides additional information.

OXIDATION CATALYST SYSTEM

A catalytic converter, in place of the conventional front silencer is situated in the exhaust system to the rear of the point in the system where both exhaust manifold downtake pipes combine.

The box unit contains three catalyst blocks and has sufficient volume to perform the dual functions of

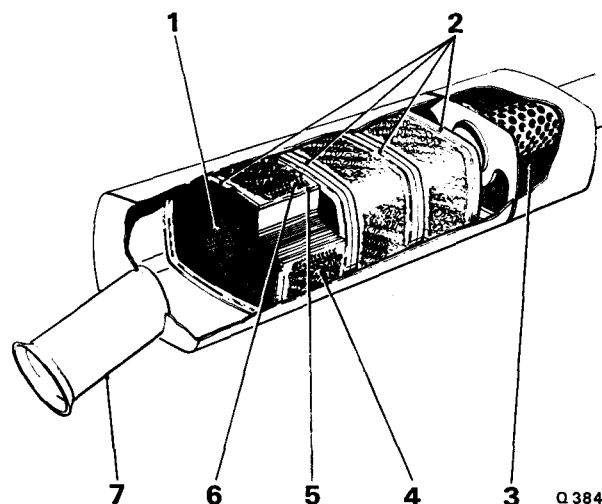

FIG. 3 CATALYTIC CONVERTER

- 1 Monolithic catalyst
- 2 Catalyst retaining plates
- 3 Silencing chamber
- 4 Stainless steel wire mesh
- 5 Fireclay coating
- 6 Ceramic tape
- 7 Inlet pipe

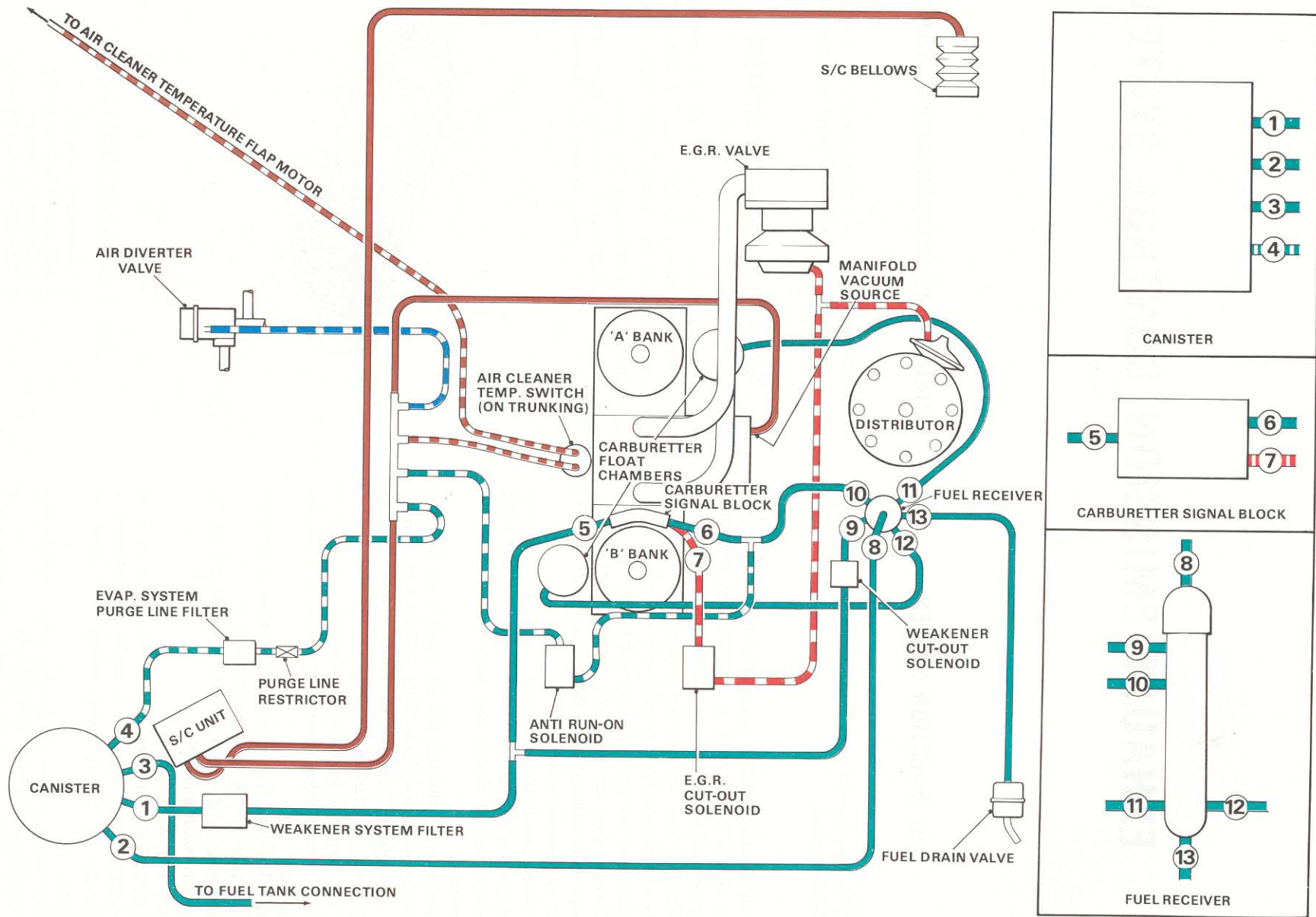

FIG. 4 HOSE ROUTING DIAGRAM

both converter and silencer (see Fig. 3). A platinum group metal catalyst on a ceramic monolith support is used for optimum conversion efficiency and rapid warm-up. Three separate blocks are used to minimise the effect of thermal shock and are positioned to ensure good gas distribution and effective utilisation of the catalyst volume.

The catalyst promotes reaction between the residual hydrocarbons and carbon monoxide in the exhaust and the secondary air injected into the exhaust ports. After completion of the oxidation process the exhaust gas is discharged to the atmosphere from the tailpipe.

Catalytic converter protection

To protect the catalytic converter from possible damage the following precautions should be taken.

(i) **Unleaded gasoline**

Use unleaded gasoline only. The use of leaded gasoline will result in a **substantial reduction in the performance of the catalyst**. Under no circumstances add fuel system cleaning agents to either the fuel tank or carburettors for induction into the engine, as these materials may have a **detrimental effect on the catalytic converter**.

(ii) **Engine malfunction**

If the engine misfires or suffers from a lack of power which could be attributed to a malfunction of either the ignition or fuel systems, the vehicle **should be driven only at low speed** and the fault rectified as soon as possible by an authorised dealer. Driving at high speeds with a malfunction in either of these systems could cause overheating and consequent damage to the catalyst.

(iii) **Fuel**

Do not allow the engine to run out of fuel. If the engine does run out of fuel at a high speed possible **damage to the catalyst could result**.

For information concerning the protection of the catalytic converter from damage due to overheating, refer to—Catalytic converter and body floor overheat warning system.

Catalytic converter—To remove

1. Unscrew the self-tapping screws that secure the shield below the catalytic converter assembly. Withdraw the shield.

2. Unscrew the $\frac{7}{8}$ in. A/F nuts that secure the two shields to the exhaust pipe on either side of spherical joint, situated to the rear of the body cross-member.

3. Collect the washers, withdraw the bolts and remove the shields.

Note Take care when removing the shields as the edges are sharp and could cause injury to the hands.

4. Remove the thermocouple from the catalytic converter assembly [refer to Emission Control Systems (Electrical Components) in this Supplement].

5. Support the weight of the exhaust pipe which passes into the expansion box.

6. Using a $\frac{1}{2}$ in. A/F spanner unscrew and remove the nut retaining the exhaust mounting around the exhaust pipe (situated behind the body cross-member).

7. Remove the nut and withdraw the bolt, collect the washer.

8. Open the mount and slide it over the exhaust pipe.

9. Slacken the two $\frac{9}{16}$ in. A/F nuts retaining the exhaust clamp around the spherical joint to the rear of the body cross-member and catalytic converter assembly.

10. Unscrew the nuts completely and withdraw the bolts; collect the washers.

11. Remove the two halves of the clamp joint from the exhaust pipe. Free the two sections of the pipe from each other and collect the sealing ring.

12. Allow the forward section of the exhaust to rest on the body cross-member and repeat Operations 9 to 11 inclusive on the spherical exhaust joint situated in front of the catalytic converter assembly. Hold the forward end of the assembly as the front joint is freed.

13. Withdraw the catalytic converter assembly in a forward and downwards direction.

Catalytic converter—To fit

Fit the catalytic converter assembly by reversing the procedure given for removal, noting the following points.

1. The seal rings and pipe flares must be thoroughly clean and free from scale and may be lightly dressed with fine emery cloth if required.

2. The clamp bolt threads should be lightly oiled to prevent binding during assembly and the spherical faces of the sealing rings and the grooves in the clamps should be smeared with a graphite lubricant, to ensure correct alignment of the pieces on assembly.

3. Fit the pipe and the catalytic converter assembly complete with seal rings, then loosely fit the joint clamps and the 'handcuff' clamp.

Chapter U

4. The joints must not be fully tightened until the pipe has been manoeuvred to obtain the best run (free from possible fouls) and good joint alignment.

Note The pipe joints must not be 'sprung' or 'clamped' into position.

5. When the pipe run is satisfactory, torque tighten the joint clamp nuts in accordance with the standard torque figures given in Chapter P then 'set' the 'Vibrashock' mount to allow for expansion in the exhaust system, when hot.

6. Fit the thermocouple to the catalytic converter assembly [refer to Emission Control Systems (Electrical Components) in this Supplement].

**Catalytic converter and body floor
overheat warning system**

For all information associated with catalytic converter overheating and the overheat warning buzzer sounding, refer to Emission Control Systems (Electrical Components) in this Supplement.

'Vibrashock' exhaust mount—To set

This exercise is carried out by holding the 'handcuff' clamp forward whilst tightening the pinch bolt. This has the effect of misaligning the centre of the mount and this misalignment should be approximately 4,76 mm. (0.187 in.) at the mount centre.

FUEL EVAPORATION EMISSION CONTROL SYSTEM

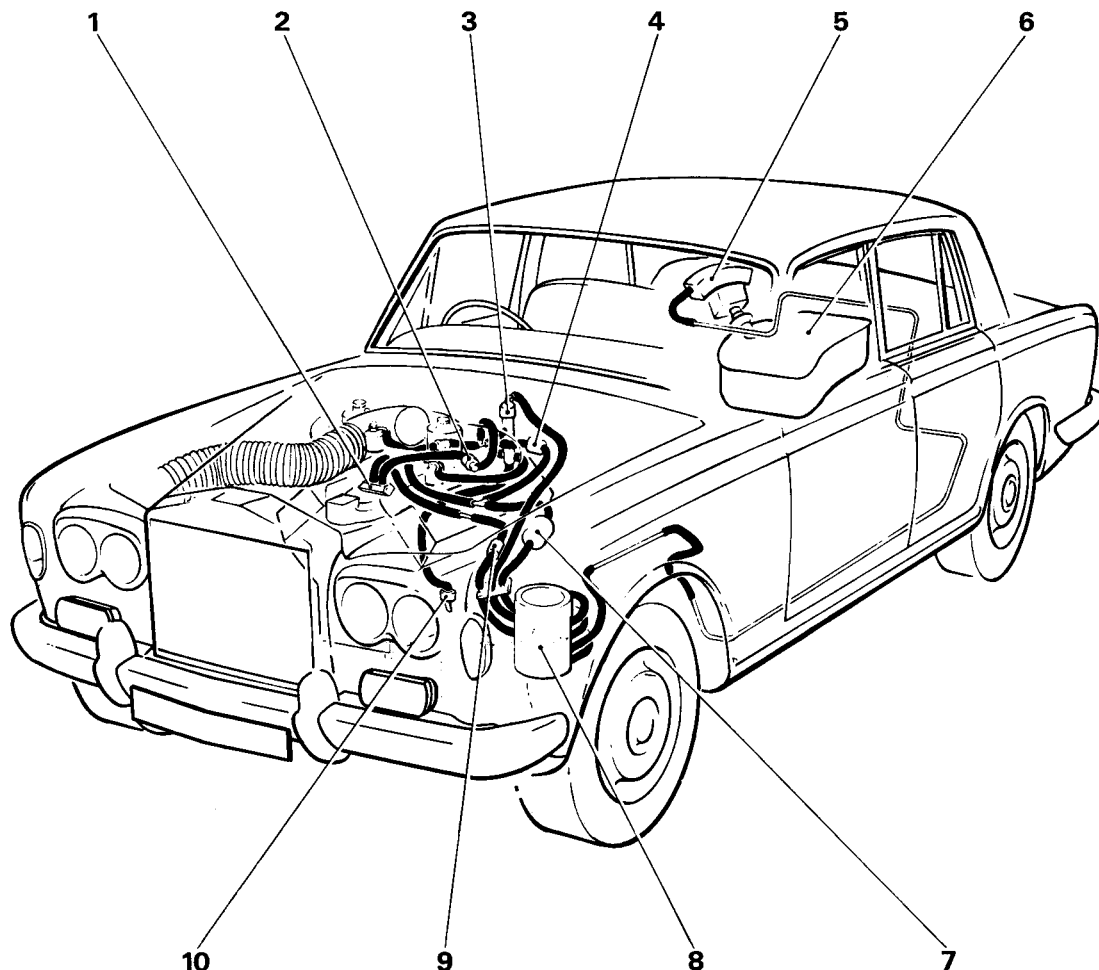

R 233

FIG. 5 FUEL EVAPORATION EMISSION CONTROL SYSTEM—GENERAL VIEW

- | | |
|-----------------------------|-------------------------------------|
| 1 Vacuum manifold | 6 Fuel tank assembly |
| 2 Anti 'run-on' solenoid | 7 Weakener filter |
| 3 Float chamber vent valve | 8 Evaporative loss control canister |
| 4 Weakener cut-off solenoid | 9 Purge line filter |
| 5 Fuel trap assembly | 10 Float chamber drain valve |

Fuel tank assembly

The fuel tank assembly consists of the fuel tank, expansion tank and fuel trap assembly (see Fig. 6).

The fuel tank is vented from three positions to a fuel trap assembly which is mounted above the fuel filler. One vent is from the fuel filler neck and the other two vents from the fuel tank.

The three vent lines join at a common junction block situated adjacent to the fuel filler neck, the main vent line then encircles the fuel tank before passing to the fuel trap assembly.

From the fuel trap, a vent line passes under the floor of the car to the evaporation loss control canister.

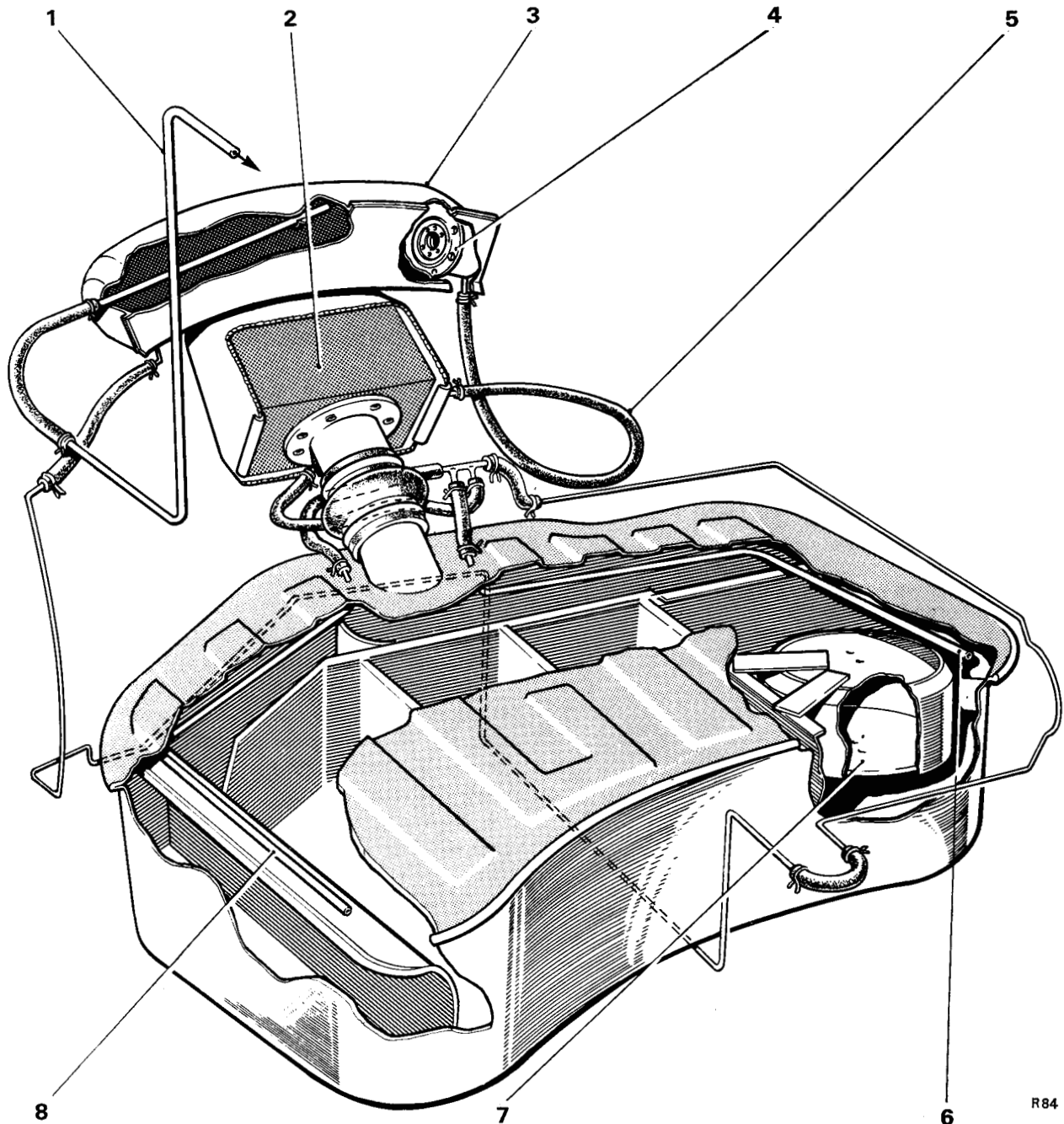

FIG. 6 FUEL EVAPORATION EMISSION CONTROL SYSTEM—FUEL TANK

1 Connection to evaporation loss control canister
2 Fuel filler box

3 Fuel trap
4 Combined relief and vacuum valve

5 Valve vent
6 Vent pipe
7 Expansion tank
8 Vent pipe

Chapter U

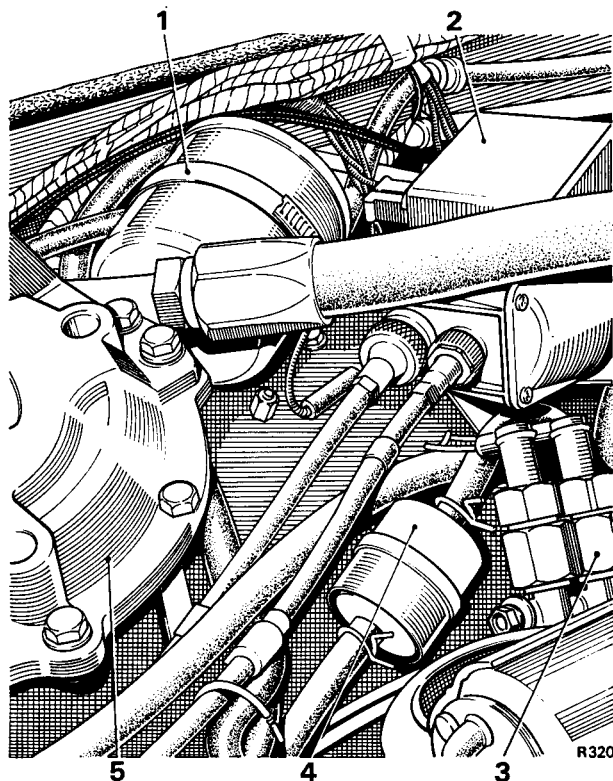

FIG. 7 POSITION OF MIXTURE WEAKENING DEVICE FILTER AND PURGE LINE FILTER

- 1 Weaker filter
- 2 Speed control system regulator
- 3 Hydraulic fluid pressure switches
- 4 Purge line filter
- 5 Road spring top cover

Purge line

The purge line consists of a rubber hose, passing from the lowest connection on the canister through the valance junction piece to the vacuum manifold. Incorporated into this hose is the purge line filter and restrictor.

When the engine is running, air drawn through the canister filter and carbon picks up the stored fuel vapours and passes them via the hose, to the induction manifold. The restrictor in the line controls the flow rate at between 1,41 cu. m./hr. and 1,98 cu. m./hr. (50 cu. ft./hr. and 70 cu. ft./hr.) to maintain carburettor metering accuracy and the paper element line filter is fitted to prevent blockage of the restrictor.

Purge line filter—To remove

1. Using special pliers (RH 8090) remove the two steel retaining clips situated on either side of the unit.

2. Slacken the setscrew which secures the nylon retaining clip.
3. Withdraw the component from the clip.

Purge line filter—To fit

Fit the purge line filter by reversing the procedure given for removal noting the following point.

1. Ensure that the rubber hoses are in a good condition and new hose retaining clips are used.

Purge flow rate—To check

Check the purge flow rate as follows.

1. Disconnect the hose from the engine side of the purge line filter and insert a flowmeter and stand assembly (RH 8725) into the line. The flowmeter is a rotameter type capable of measuring between 1,41 cu. m/hr. and 1,98 cu. m/hr. (50 cu. ft/hr. and 70 cu. ft/hr.). The pressure drop across the meter is not to exceed 5,08 cm. Hg. (2 in. Hg.).
2. Start and run the engine at idle speed, the flowmeter reading should be between 1,41 cu. m/hr. and 1,98 cu. m/hr. (50 cu. ft/hr. and 70 cu. ft/hr.).
3. If the flow is less than 1,41 cu. m/hr. (50 cu. ft/hr.) stop the engine and remove the purge line restrictor (see Fig. 4). Fit a piece of straight metal pipe with an internal bore larger than 4,76 mm. (0.187 in.), in place of the restrictor.
4. Start and run the engine at idle speed, ensure that the flow is now in excess of 1,98 cu. m/hr. (70 cu. ft/hr.).
5. If the flow is less than 1,98 cu. m/hr. (70 cu. ft/hr.) check the following.
 - (i) an air leak in any of the vacuum hoses connected to the vacuum manifold (see Fig. 4).
 - (ii) a blockage in the vacuum manifold or any of the connecting hoses (see Fig. 4).
6. Rectify any air leaks or blockages found in the system. Repeat Operation 4.
7. Stop the engine and fit the purge line restrictor.
8. Start the engine and check the flow rate as detailed in Operation 2.
9. If the flow is still incorrect fit a new restrictor and again repeat Operation 2.
10. Stop the engine, remove the flowmeter assembly and connect the hoses.

CRANKCASE EMISSION CONTROL SYSTEM

For details of this system refer to Chapter U (Part 2) and the Supplement No. 5.

EMISSION CONTROL SYSTEMS (ELECTRICAL COMPONENTS)

For servicing details of the emission related electrical components fitted to the 1976 model year car, **not** listed in this Section, refer to Chapter U (Part 2)—Section U4.

- (i) The exhaust gas recirculation valve cut-in switch.
- (ii) Electrically operated cooling system booster fan.
- (iii) Catalytic converter and body floor overheat warning system.

Exhaust gas recirculation cut-in switch

The servicing details for the component are identical to those given in Chapter U (Part 2)—Section U4. However, an additional switch has been added to the thermostat outlet elbow and therefore, reference should be made to Figure 4 in this Supplement for identification purposes.

Cooling system booster fan

A cooling system booster fan is fitted to increase the flow of air through the radiator matrix at high coolant temperatures (e.g. if the engine is allowed to run at idle for long periods).

Important Under certain conditions it is possible for the cooling system booster fan to start when the engine is not running.

The fan installation is illustrated in Figure 9.

The switch to activate the fan is illustrated in Figure 8.

Cooling system booster fan—To remove

1. Disconnect the battery and remove the radiator grille (refer to Chapter S).
2. Disconnect the electrical feed to the fan by detaching the two 'Lucar' connections situated to the left of the steering pump oil cooler (see Fig. 9).

3. Remove the four screws retaining the outer ends of the cross-stays that carry the booster fan assembly. Withdraw the fan assembly taking care not to damage the refrigeration condenser.

Cooling system booster fan—To dismantle

1. Release the clip securing the electrical feed cables to the upper cross-stay.
2. Remove the screws retaining the fan to the drive hub. Withdraw the fan.
3. Slacken the small grub screw and withdraw the fan drive hub from the fan motor shaft.

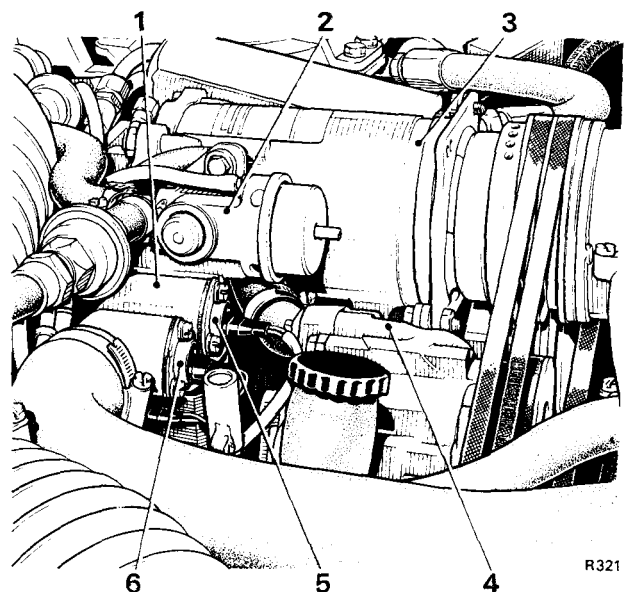

FIG. 8 THERMOSTAT ELBOW CUT-IN SWITCHES

- 1 Thermostat outlet elbow
- 2 Air diverter valve
- 3 Refrigeration compressor
- 4 Air pump
- 5 Cooling system booster fan switch
- 6 E.G.R. cut-in switch

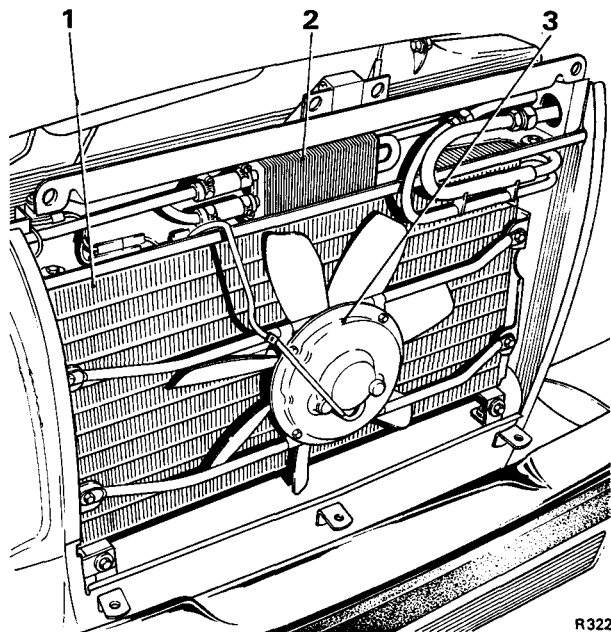

FIG. 9 COOLING SYSTEM BOOSTER FAN

- 1 Refrigeration condenser matrix
- 2 Steering pump oil cooler
- 3 Cooling system electric booster fan

4. Unscrew the four screws securing the electric fan motor to the cross-stays.

Cooling system booster fan—To assemble

Assemble the fan by reversing the procedure given for dismantling, noting the following.

1. Ensure that the fan drive hub flange is 'flush' with the end of the drive-shaft. Tighten the grub screw.

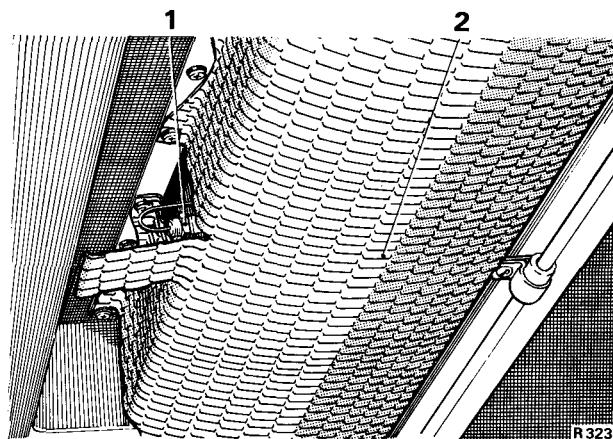

FIG. 10 CATALYTIC CONVERTER OVERHEAT PROBE

- 1 Thermocouple probe
- 2 Grass-fire heatshield

Cooling system booster fan—To fit

Fit the fan assembly by reversing the procedure given for removal.

Cooling system booster fan—To check

1. Disconnect the electrical socket from the booster fan cut-in switch (see Fig. 8).

2. Connect a short length of cable between the two connections in the socket, the fan motor should start.

Should this test prove satisfactory, but the operation of the system still be suspect, drain the coolant and replace the cut-in switch with a new unit.

Note When fitting a new cut-in switch, always ensure that the unit is the correct part as there may be similar switches fitted to the engine with different temperature settings.

Catalytic converter and body floor overhear warning system

To satisfy Japanese regulations an audible warning system is fitted to both the exhaust catalytic converter and car body floor (luggage compartment) to alert the driver if temperatures in these two areas become excessive.

The sensor for each system is shown in Figure 10 and 11 respectively.

Both warning systems utilise the same feed of the catalyst control unit (mounted under the front left-hand wing above the under wing sheet) and warning buzzer situated between the front seats (below the centre console on coachbuilt cars or below the stowage compartment on Silver Shadow cars).

If the temperature of either the catalytic converter or the car floor become excessive a warning buzzer will sound inside the car.

Overheat warning

Should an exhaust overheat condition be signalled the speed of the vehicle must be reduced to 50 k.p.h. (30 m.p.h.) immediately and this speed must not be exceeded until the cause of the overheat warning has been investigated and corrected.

Before carrying out a full diagnostic inspection two possible causes should be explored as follows:

- (a) Ensure that the vehicle did not run out of fuel.
- (b) In an ambient air temperature of above 30°C. (86°F.) ensure that the air conditioning system upper air facia switch is turned towards the 'cold

quadrant' (situated on the left-hand side and coloured blue) to activate the fuel cooler.

If the overheat warning buzzer sounds for reasons other than those detailed above a fault has occurred in:

- (a) The various systems that lead into the exhaust (i.e. fuel system, air injection system, etc.) or in the exhaust itself particularly the catalytic converter. Any faults in these areas can be determined as **system faults**.
- (b) The overheat warning circuit (i.e. faulty converter thermocouple, wiring, connections, sensors, etc.) causing the buzzer to sound although the system is operating satisfactorily. These faults can be determined as **circuit faults**.

Further conditions may apply when investigating possible faults with the overheat warning system, as follows:

- (a) The car has been returned with the warning **buzzer sounding**.
- (b) The car has been returned for investigation when the warning buzzer has sounded, but is **not sounding at the time of the investigation**.

Buzzer sounding

1. Ensure that the normal safety precautions (i.e. handbrake or parking brake is firmly applied, etc.) are carried out and the ignition is switched on.

2. Carefully observe if the vehicle appears **exceptionally hot** particularly in the area of the catalyst converter. If hotter than is usual for a car fitted with a catalyst suspect a **system fault**.

3. Raise the car bonnet, locate the Lucar connections for the catalyst converter thermocouple and disconnect the brown cable. The connections are situated adjacent to the front left-hand road spring pot cover and the valance. The two cables one brown and one blue, together with the control box loom enter the engine compartment from under the front wing (see Fig. 13).

- 4 (a) If the buzzer ceases to operate a **system fault** can be suspected, proceed to Operation 5.
- (b) If the buzzer continues to operate a **circuit fault** can be suspected, proceed to Operation 5.

After Operation 4 connect the brown cable.

5. Open the luggage compartment and carefully pull the carpet and felt from the floor at the forward end to determine if the metal floor in the area of the sensor is hot (see Fig. 11).

Note The floor temperature in this area could be extremely high and therefore, care must be taken when carrying out this test to avoid personal injury.

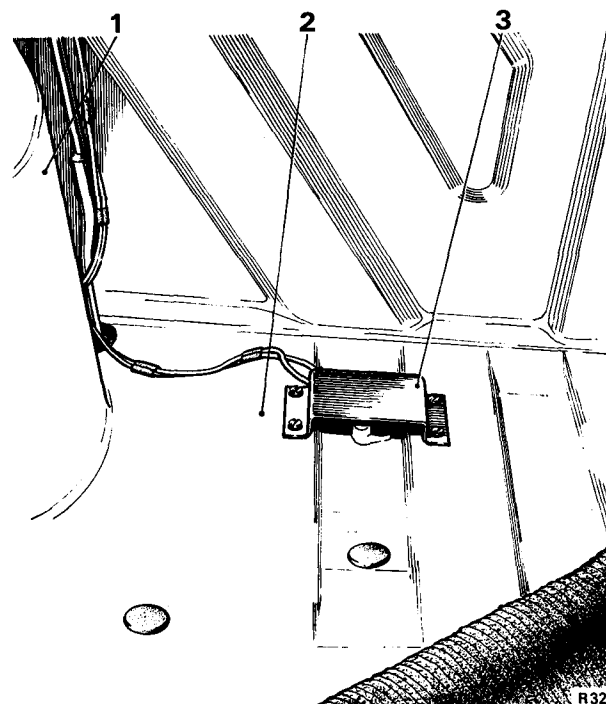

FIG. 11 BODY FLOOR TEMPERATURE SENSOR

- 1 Rear spring housing
- 2 Luggage compartment floor
- 3 Overheat sensor

6. (a) If the luggage compartment floor is very hot a **system fault** could be causing excessively high temperatures in the exhaust.
- (b) If the luggage compartment floor is cool or warm proceed to Operation 7.

7. Remove the metal cover fitted over the luggage compartment floor sensor and disconnect one of the Lucar connections to the sensor. If the buzzer ceases to operate the sensor should be tested (see Service Checks—Luggage compartment floor temperature sensor) and if found suspect in any way, renewed.

8. If the buzzer continues to operate refit all components in the luggage compartment.

9. Position the car on a ramp and carry out Operation 1.

10. From beneath the car, carefully observe the area around the catalyst converter assembly. The catalytic converter and surrounding area will normally be very hot, however, excessive temperature caused by a **system fault** will result in the overheat warning buzzer sounding.

11. Switch off the ignition and allow the car to cool down. When the car is cold switch on the ignition and check the buzzer as follows.

- (a) If the buzzer is still sounding suspect a **warning circuit fault** and check out the circuits as detailed in the service checks.

Chapter U

(b) If the buzzer is not sounding suspect a fault in one of the systems feeding into the exhaust (system fault).

From the evidence gained by carrying out Operations 1 to 11 inclusive it can be determined if the vehicle has a **system fault** or a **warning circuit fault** and the information listed in the appropriate section should be consulted.

Buzzer not sounding at the time of investigation

1. Ensure that the normal safety precautions (i.e. handbrake or parking brake is firmly applied, etc.) are carried out and the ignition is switched on.
2. Raise the car bonnet and carry out service checks on the **catalytic converter thermocouple** and **control box**.
3. Open the luggage compartment and carry out service checks on the **floor overheat warning system** wiring and switch.
4. If all the service checks on the warning circuits prove satisfactory a **system fault** should be suspected.

From the evidence gained by carrying out Operations 1 to 4 inclusive it can be determined if the vehicle has a **system fault** or a **warning circuit fault** and the information listed in the appropriate section should be consulted.

System faults

The following is a list of components and systems that may contribute to a malfunction in the exhaust resulting in overheating of the catalytic converter or luggage compartment floor.

Note Any condition resulting in an engine misfire or uneven running should always be investigated first as this condition could result in the catalytic converter overheating.

1. Faulty air injection system.
2. Faulty air diverter valve.
3. Ignition system faulty (including ignition timing).
4. Fouled sparking plugs.
5. Incorrect float chamber depression.
6. Air conditioning system faulty.
7. Blocked fuel feed line.
8. Fouled float chamber filters.
9. Choke system operation incorrect (including choke hold solenoid).
10. Sticking carburetter piston.
11. Fouled carburetter float chamber or jet.
12. Exhaust gas recirculation valve failed.
13. Air leak into induction system.
14. Failed exhaust gas recirculation cut-in solenoid, cut-in switch or electrical supply circuit.
15. Failed anti 'run-on' solenoid or electrical supply circuit.
16. Faulty hot idle mixture compensator.

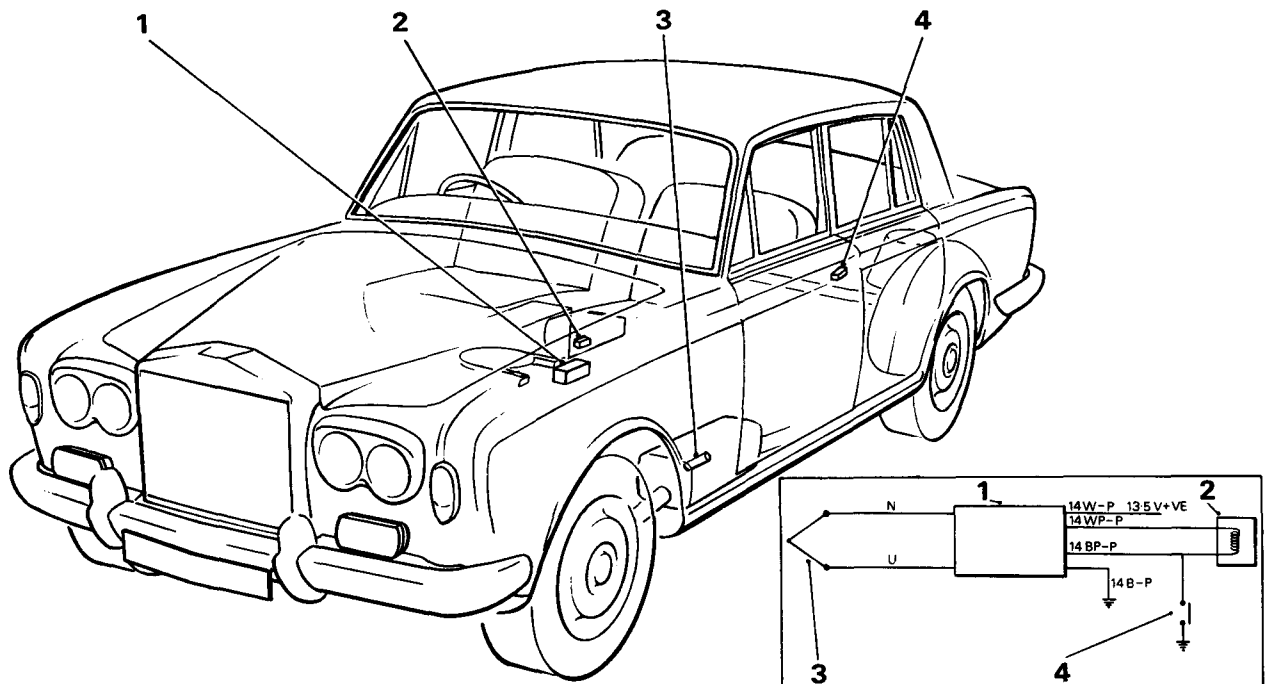

FIG. 12 OVERHEAT WARNING SYSTEM

1 Control unit
2 Warning buzzer

3 Catalyst thermocouple probe

4 Luggage compartment floor temperature sensor

17. Weakening device filter blocked or blockage in rubber connecting hoses.
18. Flooding of carburettor float chamber or jet.
19. Incorrect operation of temperature controlled air intake system.
20. Incorrect purge flow rate.

Note Should the overheat warning buzzer sound while testing is in progress, disconnect and blank off the air injection system check valves. This action should prevent overheating of the catalyst whilst the remaining tests are completed.

Warning circuit faults

The following is a list of components within the overheat warning system that may contribute to a malfunction of the warning system.

A theoretical wiring diagram of the warning circuits is illustrated in Figure 12.

1. Catalyst overheat warning control box and wiring.
2. Catalyst thermocouple probe and wiring.
3. Luggage compartment floor temperature sensor and wiring.
4. Warning buzzer.

These components together with the necessary wiring and connections can be checked by carrying out the relevant service checks.

SERVICE CHECKS

Catalyst overheat warning control box and buzzer—To check

1. Raise the car bonnet, locate the control box loom and the two catalyst thermocouple cables on the left-hand valance adjacent to the front road spring pot cover (*see Fig. 13*).
2. Identify the two catalyst thermocouple cables, one is brown and the other is blue.
3. Disconnect the blue cable at the Lucar connection and connect the end from the control box through a 9 k resistor to Positive (this can be the white wire in the control box loom).
4. Switch on the ignition, if the control and wiring is correct the warning buzzer will sound.
5. Remake the electrical connections.

Catalyst thermocouple probe—To check

1. Raise the car bonnet, locate the control box loom and the two catalyst thermocouple cables on the left-hand valance adjacent to the front road spring pot cover (*see Fig. 13*).

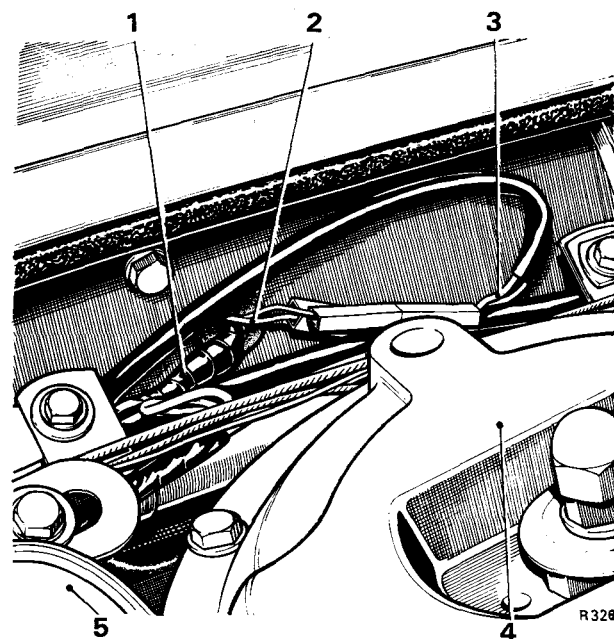

FIG. 13 CATALYTIC CONVERTER THERMOCOUPLE PROBE CABLES AND CONTROL BOX LOOM

- 1 Control box loom
- 2 Catalyst thermocouple cable (blue)
- 3 Catalyst thermocouple cable (brown)
- 4 Left-hand front road spring cover
- 5 Hydraulic systems reservoirs

2. Identify the two catalyst thermocouple cables, one is brown and the other blue.

3. Disconnect the two cables at their Lucar connections and using suitable equipment (e.g. an Avometer) ensure that the thermocouple probe is not open circuit.

4. Providing the thermocouple probe is not open circuit it is considered serviceable, however, should it be suspect for other reasons a new unit must be fitted.

5. Remake the electrical connections.

Luggage compartment floor temperature sensor—To check

1. Open the luggage compartment and pull the carpet and felt from the floor of the luggage compartment at the forward end (*see Fig. 11*).

2. Remove the four screws and withdraw the cover from above the sensor.

3. Detach the two cables from the sensor and using an additional short length of cable, connect the two together. If the buzzer sounds, the wiring and buzzer are satisfactory.

4. Remove the sensor from the car.

Chapter U

5. Using suitable test facilities (e.g. heated oil bath, oven, etc.) ensure that the sensor will operate at $110^{\circ}\text{C.} \pm 5^{\circ}\text{C.}$ ($230^{\circ}\text{F.} \pm 10^{\circ}\text{F.}$).

Should the switch operate within the prescribed limits it is satisfactory.

6. Fit the switch and the other components to the luggage compartment.

Catalyst thermocouple probe— To remove and fit

Refer to Page U203 of this Supplement, Catalytic converter—To remove, noting that the lock-nuts on the thermocouple mounting in front of the converter must be released and the thermocouple freed from the mounting.

Luggage compartment floor temperature sensor—To remove and fit

Refer to Page U211 of this Supplement, Luggage compartment floor temperature sensor—To check.

Catalyst overheat warning control box—To remove

1. Ensure that the normal safety precautions (i.e. handbrake or parking brake is firmly applied, etc.) are carried out. Firmly chock the wheels.

2. Raise the front of the car on a jack and position stands beneath the car.

3. Remove the front left-hand road wheel.

4. Remove the underwing sheet.

5. Raise the car bonnet, locate the control box loom and two catalyst thermocouple cables on the left-hand valance adjacent to the front road spring pot cover (see Fig. 13).

6. Disconnect the cables mentioned at their Lucar connectors and carefully feed them through the valance.

7. Remove the mounting setscrews and withdraw the control box from beneath the wing.

Catalyst overheat warning control box—To fit

1. Fit the control box by reversing the procedure given for removal, ensuring that the rubber grommet is correctly fitted to the hole in the wing valance and the cables are correctly connected in the engine compartment.

Overheat warning buzzer—To remove

The warning buzzer is situated between the front seats either beneath the centre console (Coachbuilt cars) or stowage compartment (4 Door Saloons).

1. To gain access to the buzzer it will be necessary to remove the front seats and stowage compartment/centre console (see Chapter S).

2. Detach the two electrical connections from the buzzer and unscrew the retaining screw.

Overheat warning buzzer—To fit

Fit the warning buzzer by reversing the procedure given for removal.

Anti 'run-on' solenoid—To check

1. Detach the hose from the solenoid to the 'Tee' piece at the solenoid end and connect a piece of hose of identical internal diameter, but of suitable length, to the solenoid.

2. Clean the open end of the hose.

3. Switch on the ignition.

4. Place the hose in the mouth and blow down the hose.

5. If the operation of the solenoid is correct note that the following conditions apply and connect the original hose to the solenoid.

(i) With the ignition switched on it should not be possible to blow down the hose.

(ii) With the ignition switched off the solenoid is de-energised and it should be possible to blow down the hose.

6. Replace the hose removed in Operation 1. If the operation of the solenoid is suspect, carry out the following test before fitting a new unit.

7. Remove the cap from the pressure tapping on 'A' bank carburetter float chamber. Connect a manometer, capable of measuring between 0 cm. and 15,24 cm. (0 in. and 6 in.), to the pressure tapping connection.

8. Start and run the engine at idling speed (600 r.p.m.).

9. Switch off the ignition and observe the reading on the manometer. The reading should increase momentarily to approximately 15,24 cm. (6 in.) of H_2O as the engine stops.

If the reading does not increase check the following:

(a) Blockage in the hose from the 'Tee' piece in the weakener hose to the anti 'run-on' solenoid.

(b) Blockage in the hose route (2 hoses joined by a restrictor/connector) from the anti 'run-on' solenoid to the vacuum manifold.

(c) Incorrect wiring to the anti 'run-on' solenoid.

THE CARBURETTORS AND AUTOMATIC CHOKE SYSTEM

Automatic choke stove pipe—To check

To check the stove pipe for any blockage, carry out the following procedure:

1. Start the engine and run until normal operating temperature is attained.
2. Disconnect the union at the butterfly housing (see Fig. 14) and connect a flowmeter to the pipe via connector RH 8945. The flowmeter must be a rotameter type capable of measuring up to 2,83 cu. m/hr. (100 cu. ft/hr.).
3. Start the engine and run at idle speed (i.e. 600 r.p.m.); observe the manometer reading which should be between 1,41 cu. m/hr. and 1,55 cu. m/hr. (50 cu. ft/hr. and 55 cu. ft/hr.).
4. If the manometer reading is below 1,41 cu.m/hr. (50 cu. ft/hr.), stop the engine, remove the choke stove pipe and stove assembly to check for leaks.
5. If the flowmeter reading is above 1,55 cu. m/hr. (55 cu. ft/hr.) fit a new restrictor in the end of the choke bi-metal housing.
6. Fit the choke stove pipe and stove assembly, start the engine and again observe the flowmeter reading at idle speed.
7. Disconnect the flowmeter assembly and fit the choke stove pipe to the connection on the butterfly housing.

Temperature controlled air intake

To ensure rapid warm-up and improve control of the air/fuel ratio a temperature controlled air intake is fitted (see Fig. 15).

A vacuum operated blending valve attached to the air cleaner assembly is controlled by a thermal sensor in the air intake elbow. This valve blends hot air from a pick-up point (scoop) adjacent to the exhaust manifold with cold air from under the front wing; thus maintaining a constant temperature of the intake air as it enters the carburettors.

Fuel cooler

A cooler is fitted into the fuel system and using the same refrigerant as the air conditioning system, cools the fuel before it enters the carburetter float chambers. The fuel cooler is situated adjacent to the refrigeration compressor and is illustrated in Figure 16.

Fuel cooler—To remove

1. Discharge the refrigerant (see Chapter C).
2. Unscrew the two unions connecting the cooler to the fuel pipes.

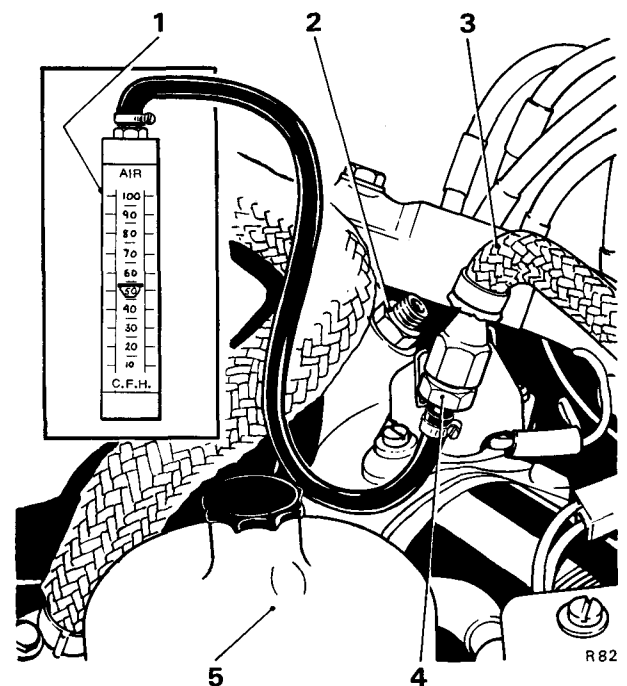
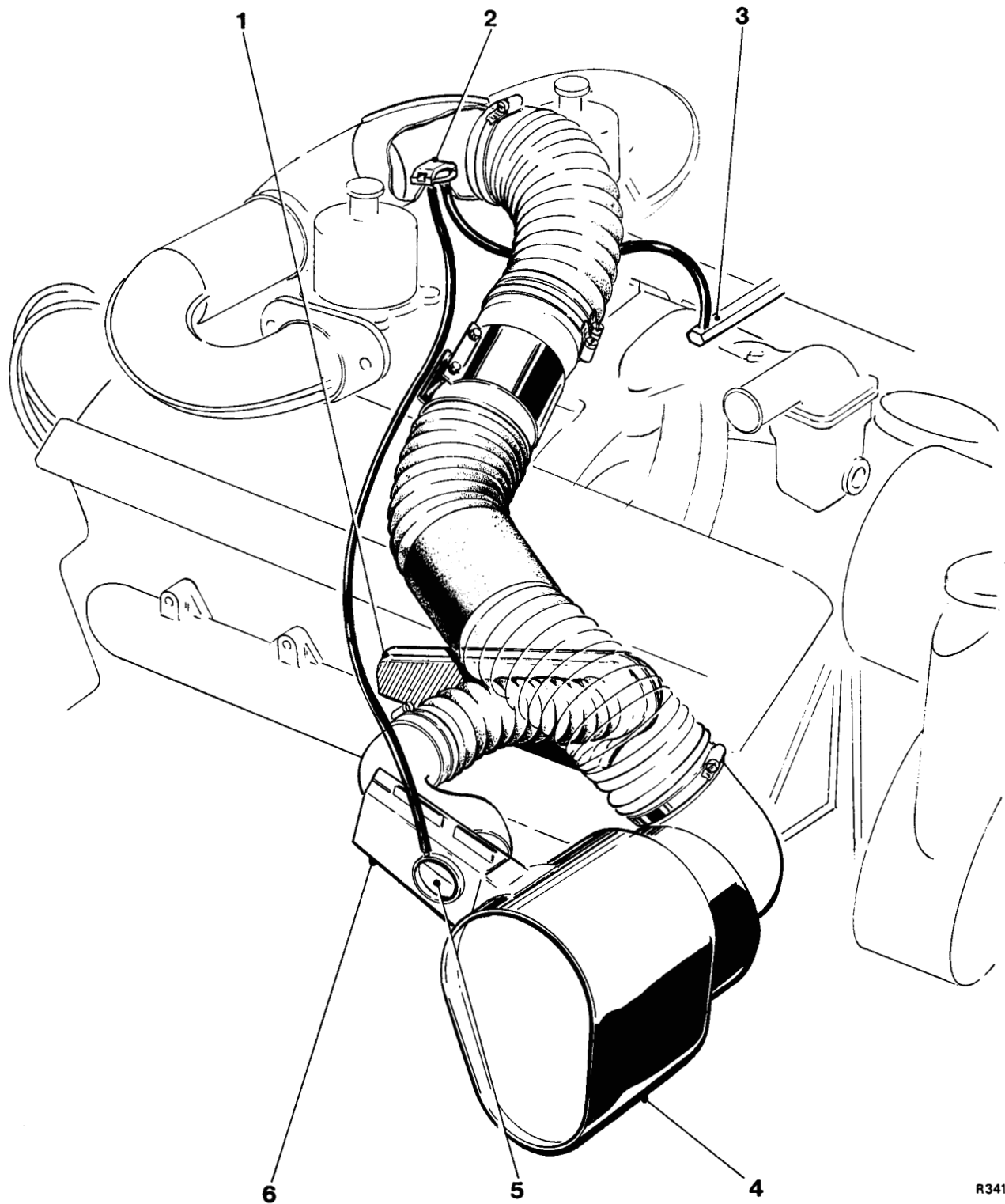

FIG. 14 CHECKING THE CHOKE STOVE PIPE DEPRESSION

- 1 Flowmeter
- 2 Choke stove pipe connection
- 3 Choke stove pipe
- 4 Adapter
- 5 'B' bank carburetter

Chapter U



R341

FIG. 15 TEMPERATURE CONTROLLED AIR INTAKE

- 1 Hot air scoop
- 2 Temperature sensor
- 3 Vacuum manifold

- 4 Air cleaner/silencer
- 5 Air blending valve
- 6 Cold air intake

3. Disconnect the refrigeration pipe from the front of the cooler.

4. Unscrew and remove the setscrew that secures the clamp plate to the rear face of the compressor.

5. Withdraw the clamp plate from the rear face of the compressor.

6. Unscrew and remove the cooler mounting setscrews situated at the forward end of the assembly; free the refrigeration pipes from the rear of the assembly. Withdraw the cooler.

Fuel cooler—To fit

To fit the fuel cooler reverse the procedure given for removal noting the following points.

1. Fit new rubber 'O' rings between the rear face of the compressor and the unions of the refrigeration pipes.

2. After fitting the cooler the full procedure of evacuation and sweeping must be carried out before the refrigeration system is charged, details are given in Chapter C.

Cold start 'fast-idle'—To set

1. Stop the engine and disconnect the solenoid to exhaust gas recirculation valve hose at the valve end. Blank the hoses. Disconnect the signal hose to the distributor vacuum capsule at the capsule and blank off the hose.

Remove the pressure tapping cap to vent the float chambers; open the throttles and close the choke butterfly against the bi-metal coil tension by means of the butterfly link lever, release the throttles.

The 'fast-idle' adjusting screw should now be resting on the high step of the 'fast-idle' cam and the throttles in the cold start position.

2. Start the engine and check the 'fast-idle' speed. If the speed is not between 1 900 r.p.m. and 2 100 r.p.m., stop the engine, open the throttles to gain

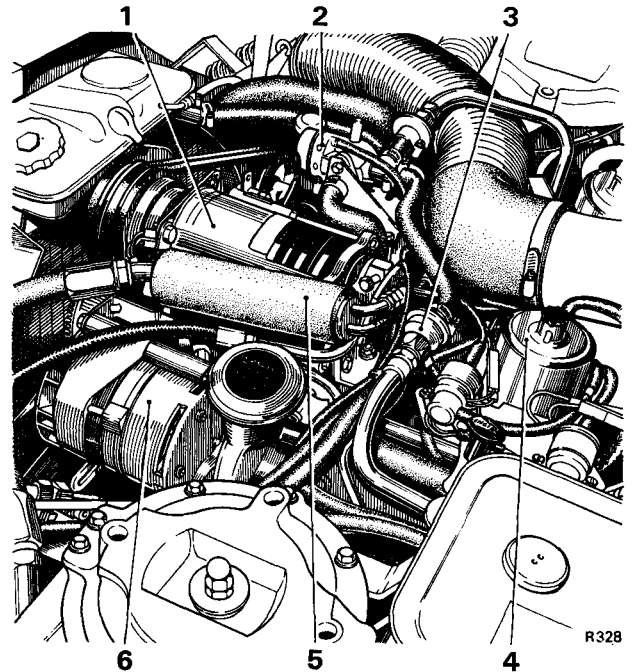

FIG. 16 FUEL COOLER

- 1 Refrigeration compressor
- 2 Air diverter valve
- 3 Check valve
- 4 'B' bank carburetter
- 5 Fuel cooler
- 6 Alternator

access to the adjusting screw and adjust $\frac{1}{8}$ turn for each 100 r.p.m. outside the required speed.

3. Tighten the lock-nut and check the 'fast-idle' speed. If the speed is correct open the throttles to release the 'fast-idle' cam mechanism.

4. Remove the blank from the solenoid to exhaust gas recirculation valve hose and connect the hose to exhaust gas recirculation valve. Fit the tapping cap to 'A' bank carburetter float chamber cover.

5. Remove the blank from the distributor advance vacuum signal hose and connect the hose to the capsule.

IGNITION SYSTEM, DISTRIBUTOR, IGNITION COIL AND SPARKING PLUGS

Data

Ignition timing 4° B.T.D.C. (static) 15° B.T.D.C. at 1 600 r.p.m. (stroboscopic) in Neutral vacuum advance disconnected and the feed hose blanked off. (Approach 1 600 r.p.m. from a higher speed).

Ignition control system

The ignition system utilises an Opus distributor (in which an oscillator pick-up and control unit replace the conventional contact breaker), a low inductance ignition coil and a ballast resistor. The control unit comprises an electronic oscillator, amplifier and power transistor.

A drum with eight ferrite rods (one per cylinder) moulded into the outer edge is mounted onto the distributor drive-shaft. As the drum rotates a voltage is created each time a ferrite rod passes the oscillator pick-up, this signal is then amplified and used to switch-off the normally conducting power transistor in the primary coil circuit thus inducing a high voltage in the secondary winding which is distributed to the sparking plugs in the normal manner.

In addition to the normal centrifugal advance mechanism the ignition distributor is fitted with a vacuum advance capsule. The E.G.R. gated orifice vacuum signal is applied to the capsule to advance the ignition timing for part throttle fuel economy during open road cruising. The vacuum signal is inhibited by a solenoid valve until a predetermined coolant temperature is reached.

This ignition control system provides increased accuracy of timing and increased service life before maintenance is required.

Ignition—To time (using a stroboscope)

The ignition is timed on A1 cylinder which is located at the front left-hand side of the engine (viewed from the front of the car).

Note If the ignition timing is to be set, ensure that the sparking plugs are in good condition before running the engine; if they require cleaning or renewal the sparking plugs gap should be set to 0,9 mm. (0.035 in.).

1. To check the ignition timing commence by running the engine until normal operating temperature is attained and the choke 'fast-idle' is in the off position. Switch off the engine.

2. Connect a stroboscope and a tachometer to the engine as described in the instructions supplied with the respective equipment. Disconnect the feed hose at the vacuum advance capsule; blank off the feed hose.

3. Start the engine and adjust the throttle stop screw to give an idle speed of 1 600 r.p.m. When setting the engine idle speed reduce from a higher speed to 1 600 r.p.m.

4. Direct the flashing light of the stroboscope onto the crankshaft damper timing marks and timing pointer; the pointer is positioned on the right-hand side of the crankshaft damper when viewed from the front of the engine.

5. If the timing pointer does not coincide with the 15° B.T.D.C. mark on the crankshaft damper adjust the ignition timing as follows.

6. Release the clamp screw on the distributor and rotate the head of the distributor in the appropriate direction until the correct timing is obtained. Clockwise rotation of the distributor head advances the ignition and conversely anti-clockwise rotation retards the ignition. After adjustment has been carried out tighten the clamp screw and again check to ensure that the timing has not altered whilst tightening the clamp screw.

7. Set the engine idle speed to 600 r.p.m.

FIG. 17 IGNITION DISTRIBUTOR

- 1 Pick-up module
- 2 Pick-up arm
- 3 Distributor cover cap
- 4 High tension brush and spring
- 5 Rotor arm
- 6 Flash over shield (dust cover)
- 7 Timing rotor
- 8 Vacuum unit
- 9 Control unit
- 10 Lubrication pad
- 11 Driving dog and pin
- 12 Thrust washer
- 13 Automatic advance mechanism
- 14 Electronic module assembly

8. Direct the flashing light of the stroboscope onto the crankshaft damper timing marks and timing pointer. Check that the ignition timing is approximately 4° B.T.D.C.

9. Stop the engine.

10. Disconnect the hose from the vacuum manifold to the purge line restrictor at the restrictor (see Fig. 4). Connect a suitable length of hose between this hose and the connection on the distributor vacuum capsule.

11. Start the engine and set the idle speed to 600 r.p.m.

12. Direct the flashing light of the stroboscope onto the crankshaft damper timing marks and timing pointer. Check that the ignition timing has advanced to approximately 14° B.T.D.C. If the ignition timing has not advanced, the distributor assembly is faulty.

13. Stop the engine.

14. Fit all hoses to their correct connections.

15. Start the engine and set the idle speed to 600 r.p.m.

16. Stop the engine and remove all the test equipment.

Setting the engine idle speed

Ensure that the engine is at normal operating temperature and that the choke 'fast-idle' is in the off position.

The air conditioning system must be switched off and a tachometer connected to the engine in accordance with the manufacturer's instructions.

1. Stop the engine, remove the air intake hose and blank off the hot idle compensator feed drilling; replace the air intake hose.

2. Start the engine and, if necessary, adjust the engine idle speed to 600 r.p.m. using the throttle stop screw; tighten the lock-nut.

3. Stop the engine and remove the air intake hose. Remove the blank from the hot idle compensator feed drilling and detach the tachometer and stroboscopic timing equipment (if fitted). Fit the air intake hose.

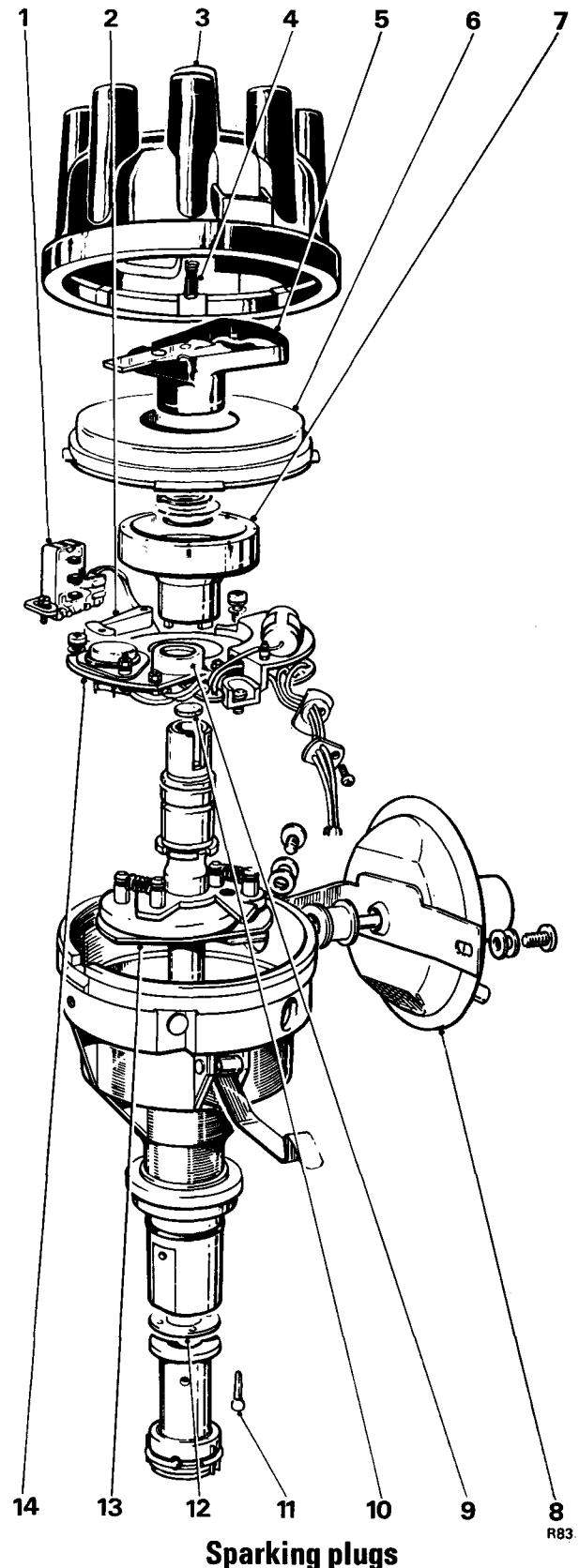

The sparking plugs approved for this car are Champion RN.14.Y. Before fitting the plugs, set the gaps to 0.9 mm. (0.035 in.) and lightly smear the threads with 'Graphogen' grease.

LUBRICATION AND MAINTENANCE

The 'Essential' maintenance which is listed in the following schedules is the minimum servicing which must be carried out at the appropriate distance/time intervals in order to comply with the Rolls-Royce new car Warranty and the Japanese Emission Regulations.

The 'Preventive' maintenance listed, is aimed at securing the maximum life and efficiency for the vehicle and will be carried out on request.

The schedules marked 'Regular' maintenance should be carried out either by the Owner, his chauffeur, or by a Distributor or Retailer.

REGULAR MAINTENANCE

Carburettors

Monthly, check the oil level in the reservoirs of the automatic air valve dampers; top-up if necessary.

Engine

Weekly or every 800 km. (500 miles), whichever is the earlier, check the oil level by means of the dipstick; top-up if necessary.

Hydraulic reservoirs

Monthly, check the level of fluid in the reservoirs for the braking and automatic levelling systems; the engine should be run for 4 minutes before checking the fluid level. Top-up if necessary to the indicated level. If frequent topping-up is required check the hydraulic systems for leaks and rectify if necessary.

Lamp units

Weekly, check all lamp bulbs for correct operation and replace any faulty bulbs.

Radiator

Every 3 months, check the level of coolant in the radiator header tank; if necessary, top-up with the correct anti-freeze/water mixture or inhibited solution.

Tyres

Weekly, check the tyre pressures; adjust if necessary. Also check the spare wheel tyre pressure; adjust if necessary. Check the tread depth of all tyres and inspect the tyres for signs of damage.

Windscreen washer

Weekly, top-up the reservoir if necessary.

ESSENTIAL MAINTENANCE

INITIAL SERVICE

This service will be carried out by the Distributor/Retailer after the first 5 000 km. (3 000 miles) or 3 months whichever is the earlier.

Items marked * will be carried out free of charge.

INITIAL 5 000 KM. (3 000 MILES) OR 3 MONTHS SERVICE WHICHEVER IS THE EARLIER

*Air injection pump

Check belt tension and reset if necessary.

*Automatic choke

Check the flow through the choke stove pipe and check for correct operation, rectify if necessary.

*Carburettors

Check oil level in air valve dampers and if necessary top-up to correct level. Check tightness of float chamber covers. Check float chamber depression, rectify if necessary. Check and if necessary reset the idle speed. Check and if necessary reset the choke 'fast-idle' speed.

Engine

Change engine oil.

*Fuel evaporation emission control system

Check the purge rate; this should be between 1,41 cu. m/hr. and 1,98 cu. m/hr. (50 cu. ft/hr. and 70 cu. ft/hr.) at 600 r.p.m. in Neutral. Pressure test the fuel tank and evaporation loss line and if necessary rectify any leaks.

*Ignition system

Check ignition timing using stroboscope and adjust if necessary; the ignition timing should be 15° B.T.D.C. with the engine running at 1 600 r.p.m. with the vacuum capsule disconnected and the feed hose blanked off.

Belt tension

Check the tension of all driving belts.

Engine cooling system

Tighten worm-drive clips of all coolant hoses.

Torque converter transmission

Check fluid level and top-up if necessary.

When checking the fluid level, avoid contact with the exhaust gas recirculation valve, heatshield and associated pipes as these components will be hot.

EVERY 5 000 KM. (3 000 MILES) OR 3 MONTHS WHICHEVER IS THE EARLIER

If the car is used for constant stop/start operation, change the engine oil.

EVERY 10 000 KM. (6 000 MILES) OR 6 MONTHS WHICHEVER IS THE EARLIER

Air conditioning system

Check the refrigeration system for correct operation, rectify as necessary. Any work must be carried out by an experienced engineer.

Engine

Change engine oil and renew oil filter element.

Exhaust system

Check grass-fire heatshields for damage. Rectify or renew shields to ensure that a minimum clearance of 5 mm. (0.20 in.) is maintained between the heatshields and exhaust pipes.

Battery

Check the level of the electrolyte in the battery; if necessary top-up with distilled water.

Belt tension

Check the tension of all driving belts.

Chapter U

Brakes

Inspect footbrake and handbrake/parking brake pad linings. When changing footbrake pads examine condition of dust excluders on calipers. Manually adjust the handbrake/parking brake pads. Inspect pipes and connections, rectify if necessary.

Fluid levels

Check all fluid levels.

Torque converter transmission

Check fluid levels and top-up if necessary.

When checking the fluid level, avoid contact with the exhaust gas recirculation valve, heatshield and associated pipes as these components will be hot.

**EVERY 20 000 KM. (12 000 MILES)
OR 12 MONTHS SERVICE
WHICHEVER IS THE EARLIER**

Air conditioning system

Check the refrigeration system for correct operation, rectify as necessary. Any work must be carried out by an experienced engineer.

Air injection pump

Check tension of pump pulley driving belt.

Air silencer

Fit a new paper filter element.

Carburettors

Top-up oil level in air valve dampers. Check tightness of float chamber covers. Check float chamber depression, rectify if necessary. Check and if necessary reset the idle speed. Check and if necessary, reset choke 'fast-idle' speed.

Crankcase emission control system

Remove and clean gauze flame traps in the crankcase breather tube. Clean the adapter in choke butterfly housing.

Engine

Change engine oil and renew oil filter element.

Exhaust system

Check grass-fire heatshields for damage. Rectify or renew shields to ensure that a minimum clearance of 5 mm. (0.20 in.) is maintained between the heatshields and exhaust pipes.

Fuel evaporation emission control system

Check the condition of the pipes and connections.

Ignition system

Fit new sparking plugs ensuring that the gaps are set to 0.9 mm. (0.035 in.).

Lubricate distributor spindle (shaft bearings) and automatic advance mechanism with engine oil.

Check the ignition timing using a stroboscope and adjust if necessary; the ignition timing should be 15° B.T.D.C. with the engine running at 1 600 r.p.m. the vacuum capsule disconnected and the feed hose blanked off.

Battery

Check the level of the electrolyte in the battery; if necessary top-up with distilled water.

Belt tension

Check the tension of all driving belts.

Brakes

Inspect footbrake and handbrake/parking brake pad linings. When changing footbrake pads examine condition of dust excluders on calipers. Manually adjust handbrake/parking brake pads. Inspect pipes and connections, rectify if necessary.

Final drive unit

Check oil level and top-up if necessary.

Fluid levels

Check all fluid levels.

Front suspension

The front suspension ball joints are sealed for life and no maintenance is required until renewal is necessary or the ball joint rubber covers are damaged. Inspect the rubber covers on the front suspension ball joints; if the covers are found to be damaged new joints and covers should be fitted.

Steering ball joints

Lubricate the six grease nipples. Inspect the rubber covers on the ball joints; if the covers are found to be damaged the joints should be dismantled and new parts fitted as necessary.

Torque converter transmission

Renew transmission fluid.

When checking the fluid level, avoid contact with the exhaust gas recirculation valve, heatshield and associated pipes as these components will be **hot**.

**EVERY 30 000 KM. (18 000 MILES)
OR 18 MONTHS SERVICE
WHICHEVER IS THE EARLIER**

Air conditioning system

Check the refrigeration system for correct operation, rectify as necessary. Any work must be carried out by an experienced engineer.

Engine

Change engine oil and renew oil filter element.

Exhaust system

Check grass-fire heatshields for damage. Rectify or renew shields to ensure that a minimum clearance of 5 mm. (0.20 in.) is maintained between the heatshields and exhaust pipes.

Battery

Check the level of electrolyte in the battery; if necessary top-up with distilled water.

Belt tension

Check the tension of all driving belts.

Brakes

Inspect footbrake and handbrake/parking brake pad linings. When changing footbrake pads examine condition of dust excluders on calipers. Manually adjust the handbrake/parking brake pads. Inspect pipes and connections, rectify if necessary.

Fluid levels

Check all fluid levels.

Torque converter transmission

Check fluid level and top-up if necessary.

When checking the fluid level, avoid contact with the exhaust gas recirculation valve, heatshield and associated pipes as these components will be **hot**.

**EVERY 40 000 KM. (24 000 MILES)
OR 2 YEARS SERVICE
WHICHEVER IS THE EARLIER**

Air conditioning system

Check the refrigeration system for correct operation, rectify as necessary. Any work must be carried out by an experienced engineer.

Air injection pump

Check tension of pump pulley driving belt.

Air injection system

Check air injection system for leaks and correct functioning. Renew any defective items.

Air silencer

Fit a new paper filter element.

Automatic choke

Check the flow through the choke stove pipe and check the system for correct functioning.

Carburettors

Clean air valves. Remove inlet unions from the float chamber covers and fit new paper filter elements. Top-up oil level in air valve dampers. Check tightness of float chamber covers. Check float chamber depression. Check and if necessary, reset the idle speed. Check and if necessary, reset choke 'fast-idle' speed.

Carburettor mixture weakening device

Renew air filter element for the carburettor mixture weakening device.

Chapter U

Crankcase emission control system

Remove and clean gauze flame traps in crankcase breather tube. Clean the adapter in choke butterfly housing.

Engine

Change engine oil and renew oil filter element.

Engine cooling system

Fit a new engine coolant thermostat and heater tap feed hose. Check the condition of all coolant hoses. Fit new hoses as necessary.

Exhaust system

Check grass-fire heatshields for damage. Rectify or renew shields to ensure that a minimum clearance of 5 mm. (0.20 in.) is maintained between the heatshields and exhaust pipes.

Fuel evaporation emission control system

Renew the foam filter element in the evaporation loss control canister. Check the purge rate; this should be between 1,41 cu. m/hr. and 1,98 cu. m/hr. (50 cu.ft/hr. and 70 cu. ft/hr.) at 600 r.p.m. in Neutral. Renew the purge line filter if necessary.

Ignition system

Fit new sparking plugs ensuring that the gaps are set to 0,9 mm. (0.035 in.).

Lubricate distributor spindle (shaft bearings) and automatic advance mechanism with engine oil.

Check the ignition timing using a stroboscope and adjust if necessary; the ignition timing should be 15° B.T.D.C. with the engine running at 1 600 r.p.m. the vacuum capsule disconnected and the feed hose blanked off. Check the vacuum advance mechanism.

Battery

Check the level of the electrolyte in the battery; if necessary top-up with distilled water.

Belt tension

Check the tension of all driving belts.

Brakes

Inspect footbrake and handbrake/parking brake pad linings. When changing footbrake pads examine condition of dust excluders on calipers. Manually adjust handbrake/parking brake pads. Inspect pipes and connections; rectify if necessary.

Final drive unit

Change oil.

Fluid levels

Check all fluid levels.

Front suspension

The front suspension ball joints are sealed for life and no maintenance is required until renewal is necessary or the ball joint rubber covers are damaged. Inspect the rubber covers on the front suspension ball joints; if the covers are found to be damaged new joints and covers should be fitted.

Fuel pumps

Remove the fuel pumps and check for pumping efficiency, fit new pumps if necessary.

Hydraulic systems

Completely drain the fluid from the hydraulic circuits. Thoroughly clean the brake fluid reservoirs and sight glasses, ensure that no foreign matter enters the systems. Fill the hydraulic systems with new approved fluid. Bleed the brakes and height control systems.

Rear wheel drive-shafts

Lubricate the rear wheel drive-shaft outer universal couplings with approved grease.

Steering ball joints

Lubricate the six grease nipples. Inspect the rubber covers on the ball joints; if the covers are found to be damaged the joints should be dismantled and new parts fitted as necessary.

Torque converter transmission

Change transmission fluid.

Fit a new intake strainer.

When checking the fluid level, avoid contact with the exhaust gas recirculation valve, heatshield and associated pipes as these components will be **hot**.

**SERVICING AFTER 40 000 KM.
(24 000 MILES) OR 2 YEARS
WHICHEVER IS THE EARLIER**

After 40 000 km. (24 000 miles) or 2 years, servicing is still due at the following intervals.

**50 000 KM. (30 000 MILES)
OR 2½ YEARS
WHICHEVER IS THE EARLIER**

Carry out the 10 000 km. (6 000 miles) service.

**60 000 KM. (36 000 MILES)
OR 3 YEARS
WHICHEVER IS THE EARLIER**

Carry out the 20 000 km. (12 000 miles) service.

**70 000 KM. (42 000 MILES)
OR 3½ YEARS
WHICHEVER IS THE EARLIER**

Carry out the 10 000 km. (6 000 miles) service.

**80 000 KM. (48 000 MILES)
OR 4 YEARS
WHICHEVER IS THE EARLIER**

Carry out the 40 000 km. (24 000 miles) service and in addition the following operations.

Exhaust gas recirculation system

Remove and clean the exhaust gas recirculation valve and feed pipes. Clean the orifices in the carburetter 'Tee' piece. Check the exhaust gas recirculation valve for correct operation.

Exhaust system

Fit a new catalytic converter assembly. Inspect the condition of the catalytic converter thermocouple and wiring, renew if there is visual evidence of damage.

PREVENTIVE MAINTENANCE

INITIAL SERVICE

This service should be carried out by the Distributor/Retailer after the first 5 000 km. (3 000 miles) or 3 months whichever ever is earlier.

Steering pump

Check the oil level in the reservoir; top-up if necessary.

Test

Road test the car for satisfactory performance.

**EVERY 10 000 KM. (6 000 MILES)
OR 6 MONTHS
WHICHEVER IS THE EARLIER**

Carburettors

Check the oil level in the air valve dampers and top-up if necessary.

Control linkages

Apply a few drops of engine oil to the accelerator linkage and to the gear range selector controls adjacent to the transmission casing.

Electrical system

Check all interior lamps, exterior lamps, instruments, warning lamps and devices for correct operation, rectify as necessary.

Handbrake/Parking brake

Lubricate the pivot pins and pulleys in the handbrake/parking brake system with approved grease.

Tyres

Check the tread depth of all tyres, inspect all tyres for signs of damage. Check all tyre pressures when cold, adjust if necessary.

Note Include the spare tyre.

Test

Road test the car for satisfactory performance.

Chapter U

EVERY 20 000 KM. (12 000 MILES) OR 12 MONTHS WHICHEVER IS THE EARLIER

Control linkage

Apply a few drops of engine oil to the accelerator linkage and to the gear range selector controls adjacent to the transmission casing.

Handbrake/Parking brake

Lubricate the pivot pins and pulleys in the handbrake/parking brake system with approved grease.

Spare wheel

Lubricate the spare wheel lowering bolt and mechanism.

Electrical system

Check all interior lamps, exterior lamps, instruments, warning lamps and devices for correct operation, rectify as necessary.

Tyres

Check the tread depth of all tyres, inspect all tyres for signs of damage. Check all tyre pressures when cold, adjust if necessary.

Note Include the spare tyre.

Test

Road test the car for satisfactory performance.

EVERY 30 000 KM. (18 000 MILES) OR 18 MONTHS WHICHEVER IS THE EARLIER

Carburettors

Check the oil level in the air valve dampers and top-up if necessary.

Control linkages

Apply a few drops of engine oil to the accelerator linkage and to the gear range selector controls adjacent to the transmission casing.

Electrical system

Check all interior lamps, exterior lamps, instruments, warning lamps and devices for correct operation, rectify as necessary.

Handbrake/Parking brake

Lubricate the pivot pins and pulleys in the handbrake/parking brake system with approved grease.

Tyres

Check the tread depth of all tyres, inspect all tyres for signs of damage. Check all tyre pressures when cold, adjust if necessary.

Note Include the spare tyre.

Test

Road test the car for satisfactory performance.

EVERY 40 000 KM. (24 000 MILES) OR 2 YEARS WHICHEVER IS THE EARLIER

Control linkage

Apply a few drops of engine oil to the accelerator linkage and to the gear range selector controls adjacent to the transmission casing.

Electrical system

Check all interior lamps, exterior lamps, instruments, warning lamps and devices for correct operation, rectify as necessary.

Fuel filter

Renew the main line filter element and clean the filter bowl.

Fuel tank

Slacken the drain plug one or two turns and allow any accumulated water to drain away. Tighten the drain plug.

Height control mechanism

Disconnect the control valve linkage ball joints. Clean, grease and refit the ball joints.

Handbrake/Parking brake

Lubricate the pivot pins and pulleys in the handbrake/parking brake system with approved grease.

Spare wheel

Lubricate the spare wheel lowering bolt and mechanism.

Tyres

Check the tread depth of all tyres, inspect all tyres for signs of damage. Check all tyre pressures when cold, adjust if necessary.

Note Include the spare tyre.

Test

Road test the car for satisfactory performance.

**SERVICING AFTER 40 000 KM.
(24 000 MILES) OR 2 YEARS
WHICHEVER IS THE EARLIER**

After 40 000 km. (24 000 miles) or 2 years, servicing is still due at the following intervals.

**50 000 KM. (30 000 MILES)
OR 2½ YEARS
WHICHEVER IS THE EARLIER**

Carry out the 10 000 km. (6 000 miles) service.

**60 000 KM. (36 000 MILES)
OR 3 YEARS
WHICHEVER IS THE EARLIER**

Carry out the 20 000 km. (12 000 miles) service.

**70 000 KM. (42 000 MILES)
OR 3½ YEARS
WHICHEVER IS THE EARLIER**

Carry out the 10 000 km. (6 000 miles) service.

**80 000 KM. (48 000 MILES)
OR 4 YEARS
WHICHEVER IS THE EARLIER**

Carry out the 40 000 km. (24 000 miles) service.

SEASONAL SCHEDULES

EVERY 12 MONTHS

Air conditioning system

Ensure that the foam filter element fitted to the scuttle intake grille is free from obstruction. On Long Wheelbase cars fitted with a centre division, check that the foam filter element fitted to the intake grille in the rear decking panel is free from obstruction.

Body

Check that the body drain holes are free from foreign matter.

Engine cooling system

Drain the coolant from the radiator and the engine crankcase. Clean any debris from the surfaces of the refrigeration condenser and radiator matrices by reverse flushing with a hose. This should be carried out just prior to the Autumn. Fill the system with the correct anti-freeze mixture (*refer to Chapter L—Engine Cooling System of this Workshop Manual T.S.D. 2476 and the latest Service Bulletin*).

EVERY 2 YEARS

In addition to the 12 monthly schedule, carry out the following.

Engine cooling system

Drain the coolant from the radiator and engine crankcase. Thoroughly reverse flush the coolant passages with a continuous flow of water. Change the coolant hoses where necessary. Fill the system with the correct anti-freeze mixture.

SERVICE RECOMMENDATIONS

80 000 KM. (48 000 MILES)

At this mileage and under normal motoring conditions it is recommended that the following servicing is carried out.

Chapter U

Hydraulic systems

Renew the front and rear accumulator to frame connector block hoses.

Examine the sub-frame to brake caliper hoses for chafing or surface cracking; renew if necessary.

160 000 KM. (96 000 MILES)

At this mileage and under normal motoring conditions it is recommended that the following servicing is carried out.

Hydraulic systems

Renew all the flexible hoses to the braking systems and the automatic height control system. Fit new seals to the disc brake calipers and the deceleration conscious pressure limiting valve.

Fuel system

Fit a new convoluted rubber hose between the fuel filler head and fuel tank assembly. Examine all flexible fuel pipes and renew any which show signs of deterioration.

SPECIAL PRECAUTIONS

Should the car be used in very cold temperatures, drain the engine sump when thoroughly warm and also drain the carburetter air valve dampers. The engine sump and carburetter air valve dampers should then be filled with oil having the following viscosity.

For constant temperatures of between 0°C. and -23°C. (32°F. and -10°F.), use a 10W/30 grade oil.

For constant temperatures of -23°C. (-10°F.) and below, use a 5W/20 grade oil.

FAULT DIAGNOSIS

SYMPTOMS	POSSIBLE CAUSE
<p>1. Engine will not start. (Starter motor operating).</p>	<p>1. (a) Ignition circuit broken. (b) Failed anti 'run-on' solenoid or failure of electrical supply circuit. (c) Ignition system faulty. (d) Damaged or contaminated ignition high-tension circuit. (e) Fault in fuel feed line or fouled float chamber filters. (f) Faulty choke bi-metal coil. (g) Choke solenoid inoperative. (h) Faulty choke 'fast-idle' mechanism. (i) Air leak into induction system. (j) Faulty hot idle mixture compensator. (k) Weakening device filter blocked or blockage in rubber connecting hoses. (l) Faulty weakener cut-off solenoid or failure of electrical supply circuit. (m) Faulty weakening device control switch or failure of electrical supply circuit. (n) Dislodged venturi in weakener device. (o) Flooding of carburetter float chamber or jet. (p) Fouled carburetter float chamber or jet. (q) Exhaust gas recirculation valve failed.</p>
<p>2. Engine idles very roughly.</p>	<p>2. (a) Ignition system faulty. (b) Fouled sparking plugs. (c) Damaged or contaminated ignition high-tension circuit. (d) Air leak into induction system. (e) Faulty hot idle compensator. (f) Weakening device filter blocked or blockage in rubber connecting hoses. (g) Dislodged venturi in weakener device. (h) Badly worn or damaged carburetter control linkage. (i) Flooding of carburetter float chamber or jet. (j) Sticking carburetter piston. (k) Fouled carburetter float chamber or jet. (l) Air leak into exhaust gas recirculation vacuum control circuit. (m) Exhaust gas recirculation valve failed. (n) Faulty air diverter valve. (o) Incorrect operation of temperature controlled air intake system.</p>
<p>3. Engine stalls.</p>	<p>3. (a) Ignition circuit broken. (b) Failed anti 'run-on' solenoid or failure of electrical supply circuit. (c) Ignition system faulty. (d) Damaged or contaminated ignition high-tension circuit. (e) Fault in fuel feed line or fouled float chamber filters. (f) Air leak into induction system. (g) Faulty hot idle mixture compensator. (h) Weakening device filter blocked or blockage in rubber connecting hoses. (i) Dislodged venturi in weakening device. (j) Badly worn or damaged carburetter control linkage. (k) Flooding of carburetter float chamber or jet. (l) Sticking carburetter piston. (m) Fouled carburetter float chamber or jet. (n) Air leak into exhaust gas recirculation vacuum control circuit. (o) Exhaust gas recirculation valve failed. (p) Faulty air diverter valve.</p>

Printed in Great Britain

March 1976

T.S.D. 2476

Chapter U

SYMPTOMS	POSSIBLE CAUSE
<p>4. (i) Engine shows signs of power loss, evident at high speeds and loading. (ii) Engine misfires particularly on hard acceleration from low speed.</p>	<p>4. (a) Ignition system faulty. (b) Fouled sparking plugs. (c) Damaged or contaminated ignition high-tension circuit. (d) Fault in fuel feed line or fouled float chamber filters. (e) Choke system operation incorrect. (f) Sticking carburetter piston. (g) Fouled carburetter float chamber or jet. (h) Exhaust gas recirculation valve failed. (i) Failed exhaust gas recirculation valve cut-out solenoid or electrical supply circuit.</p>
<p>5. Engine hesitates or misfires under light load.</p>	<p>5. (a) Failed anti 'run-on' solenoid or failure of electrical supply circuit. (b) Ignition system faulty. (c) Fouled sparking plugs. (d) Damaged or contaminated ignition high-tension circuit. (e) Fault in fuel feed line or fouled float chamber filters. (f) Air leak into induction system. (g) Faulty hot idle mixture compensator. (h) Weakening device filter blocked or blockage in rubber connecting hoses. (i) Dislodged venturi in weakening device. (j) Flooding of carburetter float chamber or jet. (k) Sticking carburetter piston. (l) Fouled carburetter float chamber or jet. (m) Incorrect purge flow rate. (n) Exhaust gas recirculation valve failed. (o) Faulty air diverter valve. (p) Incorrect operation of temperature controlled air intake system.</p>
<p>6. Increase in fuel consumption.</p>	<p>6. (a) Ignition system faulty. (b) Faulty choke bi-metal coil. (c) Choke system operation incorrect. (d) Air leak into induction system. (e) Faulty hot idle mixture compensator. (f) Weakening device filter blocked or blockage in rubber connecting hoses. (g) Faulty weakener cut-off solenoid or failure of electrical supply circuit. (h) Faulty weakening device control switch or failure of electrical supply circuit. (i) Air leaks in mixture weakening system. (j) Flooding of carburetter float chamber or jet. (k) Sticking carburetter piston. (l) Incorrect purge flow rate. (m) Exhaust gas recirculation valve failed. (n) Faulty air diverter valve.</p>
<p>7. Decrease in fuel consumption.</p>	<p>7. (a) Air leaks in mixture weakening system. (b) Incorrect purge flow rate. (c) Faulty exhaust gas recirculation temperature control switch or failure of electrical supply circuit. (d) Air leak into exhaust gas recirculation vacuum control circuit. (e) Exhaust gas recirculation valve failed.</p>
<p>8. Engine 'backfires' on overrun.</p>	<p>8. (a) Ignition system faulty. (b) Air leak into induction system. (c) Exhaust gas recirculation valve failed.</p>
<p>9. Sudden increase in engine idle speed.</p>	<p>9. (a) Faulty choke 'fast-idle' mechanism. (b) Failed carburetter overrun valve.</p>
<p>10. Excessive noise from air injection pump or system.</p>	<p>10. (a) Faulty air diverter valve. (b) Faulty or damaged air injection pump.</p>

WORKSHOP TOOLS

Tool Number Description

RH 8050	Spanner—Carburetter Jet Screw
RH 8087	Spanner—Weakener Cut-off Valve
RH 8089	Jet Centring Tool
RH 8090	Pliers—Wire Hose Clips
RH 8383	Positioning Tool—Throttle Spindle Seal
RH 8621	Adapter—Air Manifold to CO Meter
RH 8841	Dial Gauge—Carburetter Piston Lift
RH 8880	Setting Jig—Throttle Levers
RH 8945	Connector—Choke Stove Pipe

Chapter U

Chapter U

Section U10

SUPPLEMENTS

No. 8 Australia 1976

Printed in Great Britain

March 1976

T.S.D. 2476

For general details of the emission control systems Workshop Personnel should refer to Chapter U (Part 2). However, changes from Chapter U (Part 2) applicable to cars destined for Australia and built to the 1976 Specification are contained within this Supplement.

Information contained within this Supplement includes the following.

1. Exhaust Gas Recirculation System (E.G.R.—Single valve system).
2. Fuel Evaporation Emission Control System.
3. Crankcase Emission Control System.
4. Emission Control Systems (Electrical Components).
5. Carburettors and Automatic Choke System.
6. Ignition System, Distributor, Ignition Coil and Sparking Plugs.
7. Lubrication and Maintenance.

It should also be noted that the engine compression ratio has been reduced to 8.0:1 on cars produced to this specification.

Vehicle identification

Rolls-Royce motor cars conforming to the appropriate emission control regulations and produced to the 1976 specification can be readily identified as follows.

A 1976 Emission Control Certification Label (illustrated) fitted to the wing valance to the rear of the right-hand front suspension spring cover.

VEHICLE EMISSION CONTROL INFORMATION



Rolls-Royce Motors Limited

This vehicle conforms to ADR27/A regulations applicable to cars sold after 1 July 1976

Engine displacement: 6750ml
Engine family identification: No 1

Engine tune up specification

All settings are to be checked on a hot engine with transmission in neutral, ACU switched off, EGR and vacuum advance hoses disconnected and blanked off.

Idle speed: 600rpm

Ignition timing: 15° BTDC at 1600rpm

Idle CO: Preset at factory (5.0-5.5% at 600rpm with air injection disconnected, float chambers vented, and hot idle mixture compensator blanked off)

R 647

1976 EMISSION CONTROL CERTIFICATION LABEL

U231

Chapter U

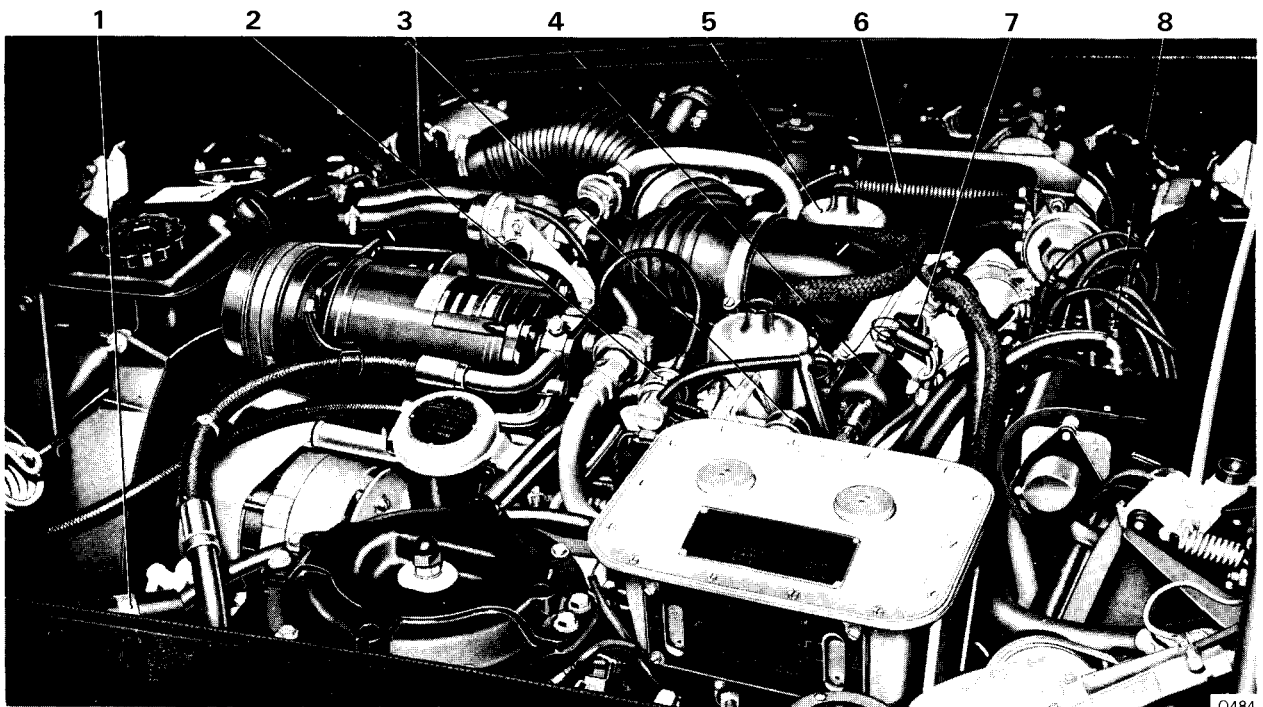

FIG. 1 VIEW INSIDE ENGINE COMPARTMENT (From Left-hand side of Car)

- | | |
|--------------------------------------|------------------------------------|
| 1 Weakener filter | 5 'A' bank carburetter |
| 2 Anti 'run-on' solenoid | 6 Exhaust gas recirculation cooler |
| 3 Exhaust gas recirculation solenoid | 7 Choke solenoid |
| 4 Choke thermo-coil housing | 8 Ignition distributor |

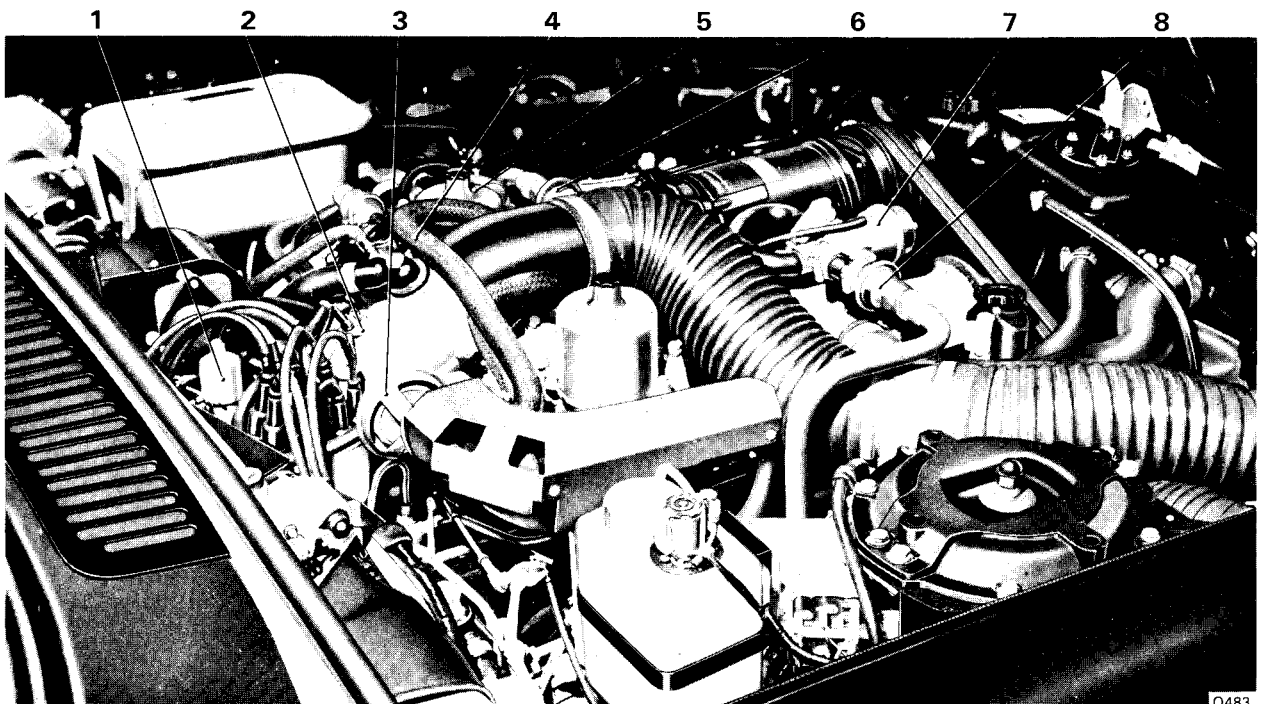

FIG. 2 VIEW INSIDE ENGINE COMPARTMENT (From Right-hand side of Car)

- | | |
|--|------------------------|
| 1 Fuel receiver and float chamber vent valve | 5 'B' bank carburetter |
| 2 Weakener system cut-off switch | 6 Check valve |
| 3 Exhaust gas recirculation valve | 7 Air diverter valve |
| 4 Exhaust gas recirculation distribution pipes | 8 Check valve |

EXHAUST EMISSION CONTROL SYSTEM

AIR INJECTION SYSTEM

Air injection system relief valve

The relief valve located in the discharge cavity of the air pump is changed from Chapter U (Part 2) and is as follows.

Air pump relief valve

A spring loaded relief valve is located within the diverter valve housing and permits excess air to bypass the air injection system when the check valves are closed. The by-pass system prevents damage to the pump vanes and excessive exhaust temperatures under extreme operating conditions.

Air diverter valve

The air diverter valve is located at the front of the engine above the air pump (*see Fig. 2*) and performs the following important function in addition to housing the pressure relief valve for the air pump.

(i) **Backfire protection** (*see Fig. 3*)

Following rapid throttle closure, the inlet manifold pressure drops suddenly, causing fuel to be vapourised from the manifold walls which results in a mixture too rich to burn in the cylinders. This mixture combined with the air injected into the exhaust ports could cause backfiring.

To prevent backfiring, the diverter valve, triggered by manifold depression diverts the injected air from the exhaust ports for a short period of time.

Air diverter valve—To check

The air diverter valve is a non-serviceable component. If the operation of the component is suspect, the following checks should be carried out before it is replaced.

1. Ensure that the parking brake is firmly applied and the vehicle is in 'Park'.
2. Start and run the engine at 2 000 r.p.m.
3. Ensure that **air does not escape** from the air diverter valve exhaust ports situated around the body of the air diverter valve (*see Fig. 3*).

If air still escapes from the exhaust ports the air diverter valve assembly is faulty due to either a failed relief valve or a seized shuttle and must be replaced.

After fitting a new air diverter valve, ensure that the component operates satisfactorily.

4. Release the throttle linkage sharply so that the engine speed rapidly falls from 2 000 r.p.m., ensure that **air escapes** from the air diverter valve exhaust ports for a short period of time.

If air does not escape from the exhaust ports of the air diverter valve during Operation 4 check the following.

- (a) The condition of the hose from the air diverter valve to the vacuum manifold (*see Fig. 5*).
- (b) The condition of any hose connected to the vacuum manifold (*see Fig. 5*).
- (c) Repeat Operation 4.

If air still does not escape during Operation 4 the air diverter valve assembly is faulty due to either a diaphragm or timing valve failure and must be replaced.

After fitting a new air diverter valve, ensure that the component operates satisfactorily.

Chapter U

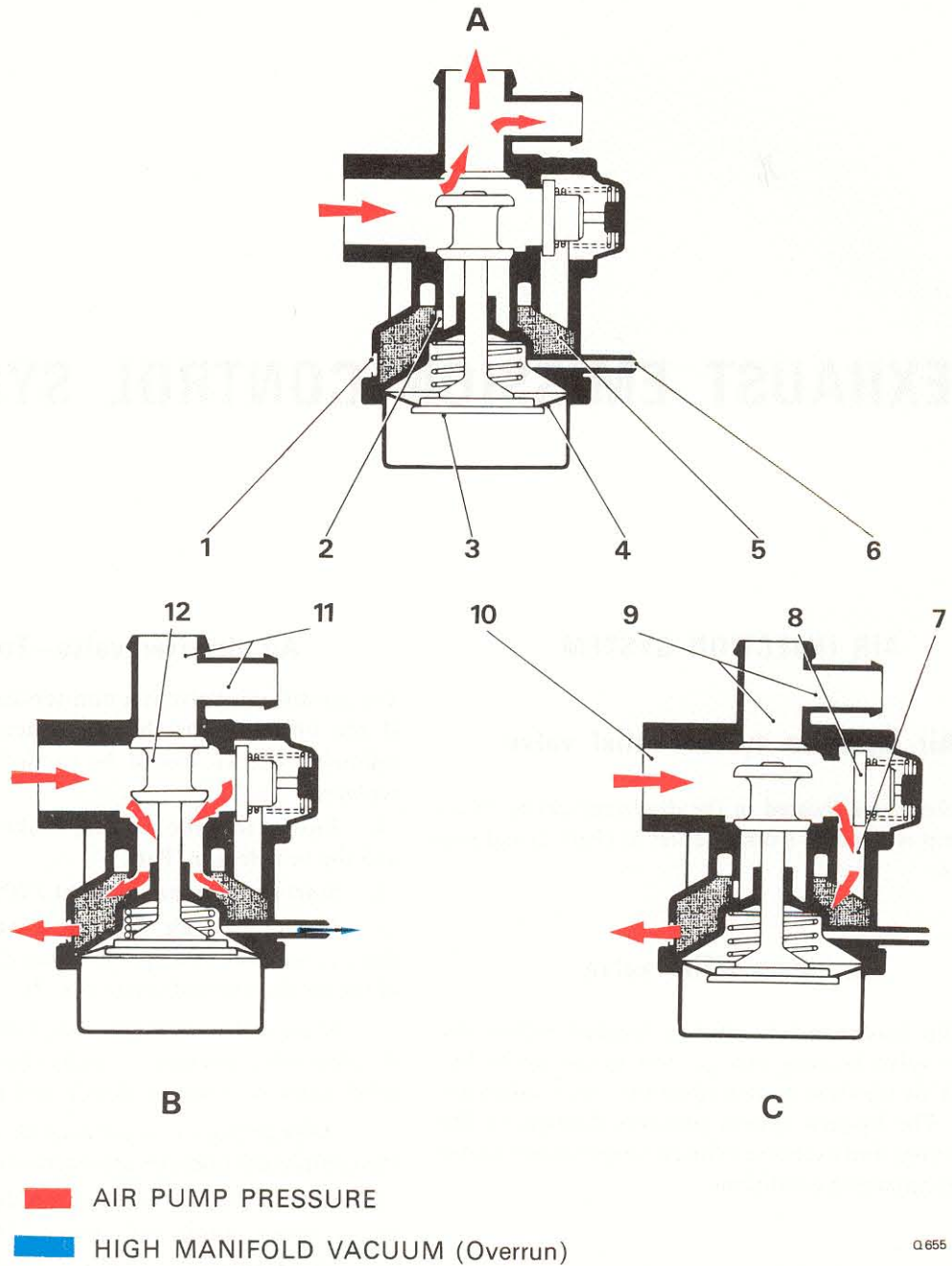

Q.655

FIG. 3 AIR DIVERTER VALVE

- | | |
|---|--|
| <p>A Normal operation</p> <p>B Backfire protection</p> <p>C Relief valve operation</p> <p>1 Exhaust to atmosphere</p> <p>2 Exhaust to internal silencer</p> <p>3 Timing valve</p> <p>4 Lower diaphragm</p> | <p>5 Internal silencer</p> <p>6 Manifold vacuum signal</p> <p>7 Excess air</p> <p>8 Relief valve</p> <p>9 Valve outlets restricted</p> <p>10 Valve inlet</p> <p>11 Valve outlets to air manifolds</p> <p>12 Metering valve</p> |
|---|--|

Chapter U

5. Allow the engine to idle at 600 r.p.m. Ensure that **air does not escape** from the air diverter valve exhaust ports.

Air diverter valve—To remove

Before commencing to remove the air diverter valve observe the following points.

1. When disconnecting the various hoses ensure that each is suitably labelled to assist identification when assembling.

2. Ensure that all open ends of pipes and hoses are suitably blanked off to prevent the ingress of dirt, etc.

diverter valve and withdraw the hoses. Two of the hoses connect to their respective air manifold check valves and the third hose to the air pump.

2. Withdraw the small diameter rubber hose from the air diverter valve.

3. Using a $\frac{7}{16}$ in. A/F spanner unscrew and remove the two nuts which secure the air diverter valve to the mounting plate. Collect the two washers.

4. Hold the air diverter valve and withdraw the two bolts from the mounting plate, taking care not to lose the washer situated under the head of each bolt.

5. Remove the air diverter valve together with the spacer plate and gasket.

To remove the air diverter valve proceed as follows

1. Unscrew the three worm drive clips which secure the three larger diameter rubber hoses to the air

Air diverter valve—To fit

Fit the air diverter valve by reversing the procedure given for removal, noting the following points.

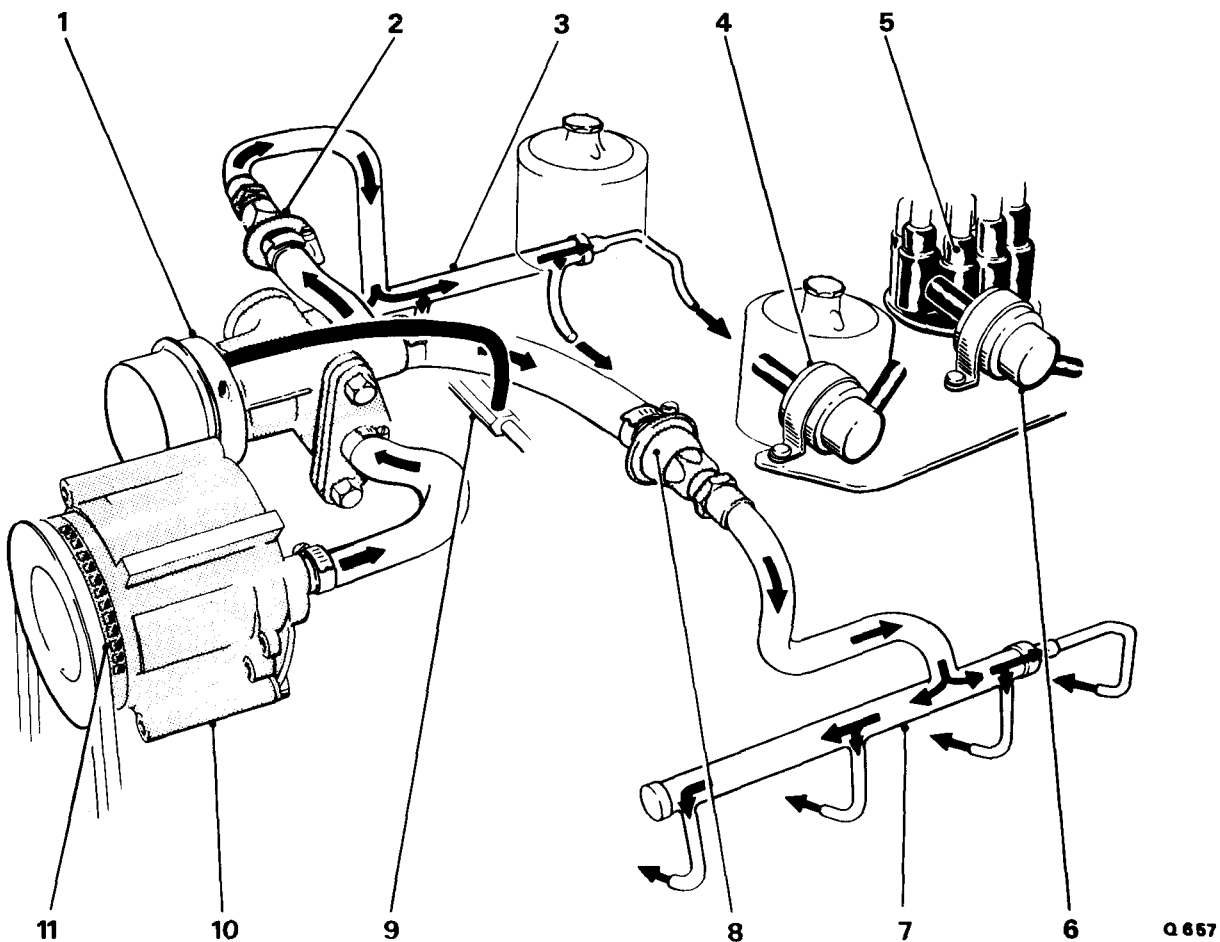

FIG. 4 AIR INJECTION SYSTEM

1 Air diverter valve
2 Check valve
3 'A' bank air manifold
4 Anti 'run-on' solenoid

5 Ignition distributor
6 Exhaust gas recirculation solenoid
7 'B' bank air manifold

8 Check valve
9 Vacuum manifold solenoid
10 Air pump
11 Air pump intake

Q 657

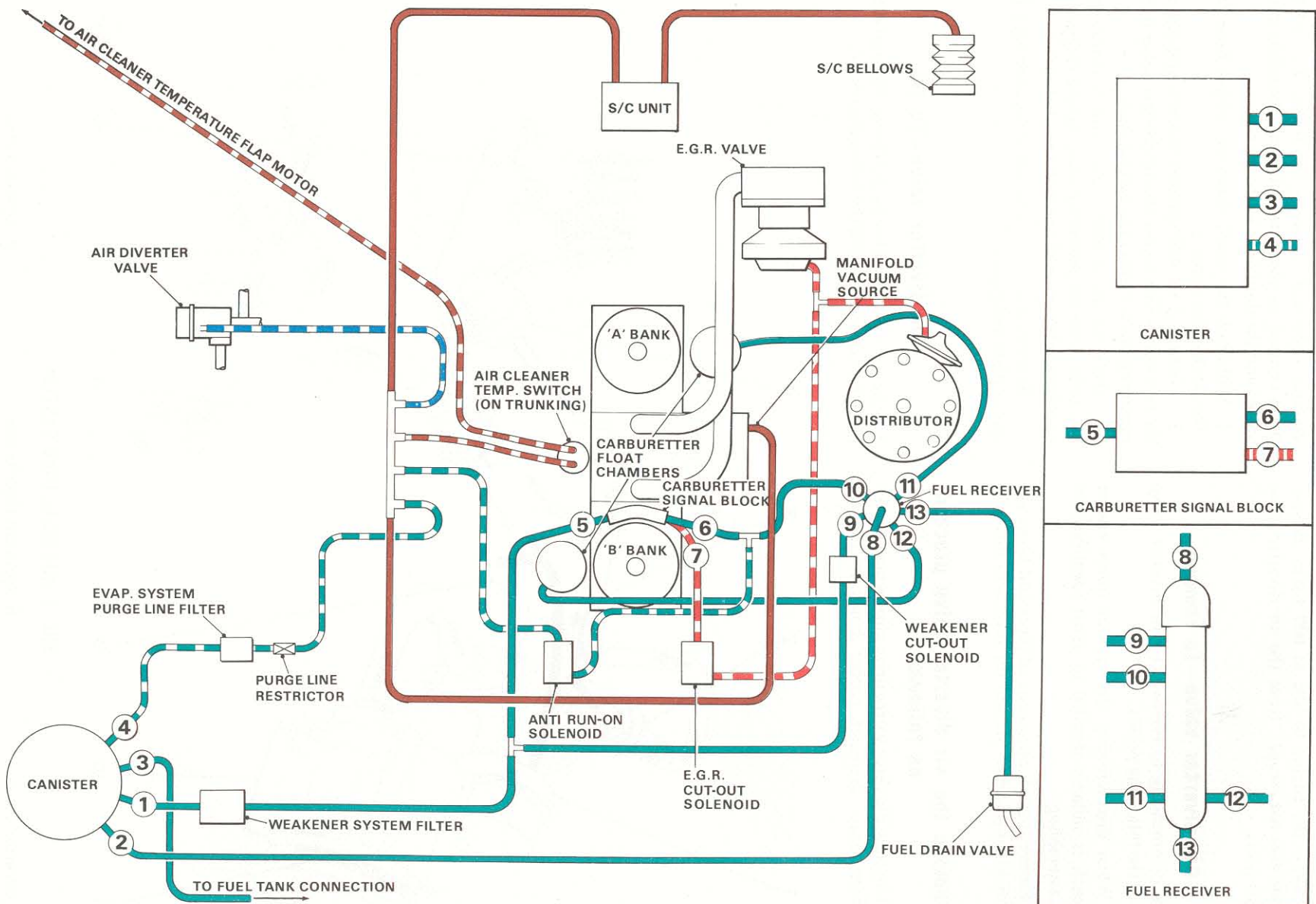

R319A

FIG. 5 HOSE ROUTING DIAGRAM—1976 MODELS

1. Ensure that all joint faces are clean.
2. Ensure that the gasket is in a good condition.
3. Always ensure that the spacer plate is fitted with the spigot projecting through the mounting plate into the hose which connects to the air pump and that the gasket is fitted to the opposite side of the mounting plate from the spigot.

For details of the remainder of the Air Injection System see **Workshop Manual T.S.D. 2476—Chapter U (Part 2)**.

EXHAUST GAS RECIRCULATION SYSTEM

This system is similar to the system detailed in Chapter U except that the 'A' bank exhaust manifold has the exhaust gas recirculation system take-off flange above the manifold as shown in Figure 6.

The exhaust gas recirculation system cooler is situated above the engine on the 'A' bank side and a large heat shield is fitted around the cooler as shown in Figure 2.

As a result of these changes the pipe run between the exhaust manifold and cooler has changed.

CAUTION

When carrying out any work in or around the area of the exhaust gas recirculation system cooler (e.g. when checking the torque converter transmission fluid level), avoid contact with the various components and pipes of the system as they contain **hot** exhaust gases when the engine is running.

A second change from Chapter U (Part 2) is the E.G.R. Full Throttle Cut-off Micro-switch, details of which are as follows.

A micro-switch operated by the throttle lever (see Fig. 7) controls the cut-off solenoid to provide exhaust gas recirculation cut-off at full throttle. This feature of the system prevents the E.G.R. valve remaining open under full throttle high speed operation, as this would be detrimental to performance and fuel consumption.

For details of the remainder of the Exhaust Gas Recirculation System see **Workshop Manual T.S.D. 2476 —Chapter U (Part 2)**.

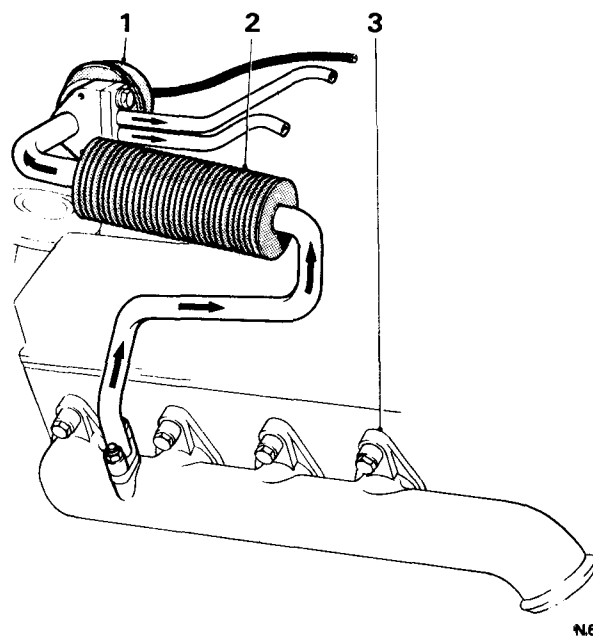

N645

FIG. 6 EXHAUST GAS RECIRCULATION SYSTEM PIPE RUN FROM EXHAUST MANIFOLD TO EXHAUST GAS RECIRCULATION VALVE

- 1 Exhaust gas recirculation valve
- 2 Exhaust gas recirculation cooler
- 3 'A' bank exhaust manifold

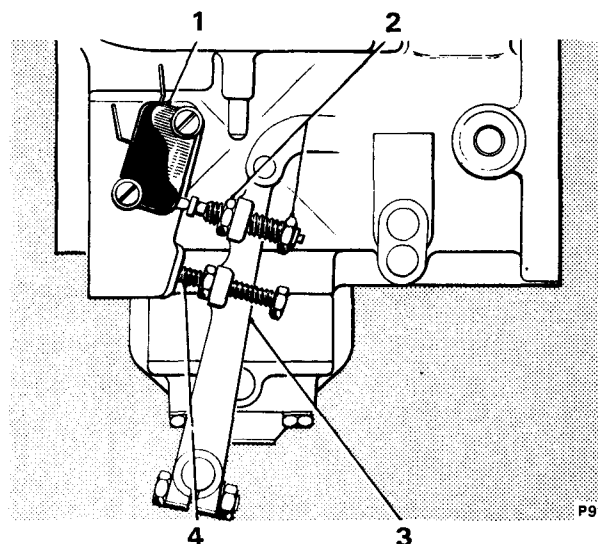

P91

FIG. 7 FULL THROTTLE CUT-OFF MICRO-SWITCH

- 1 Micro-switch
- 2 Adjusting screws
- 3 Throttle lever
- 4 Full throttle stop

Chapter U

FUEL EVAPORATION EMISSION CONTROL SYSTEM

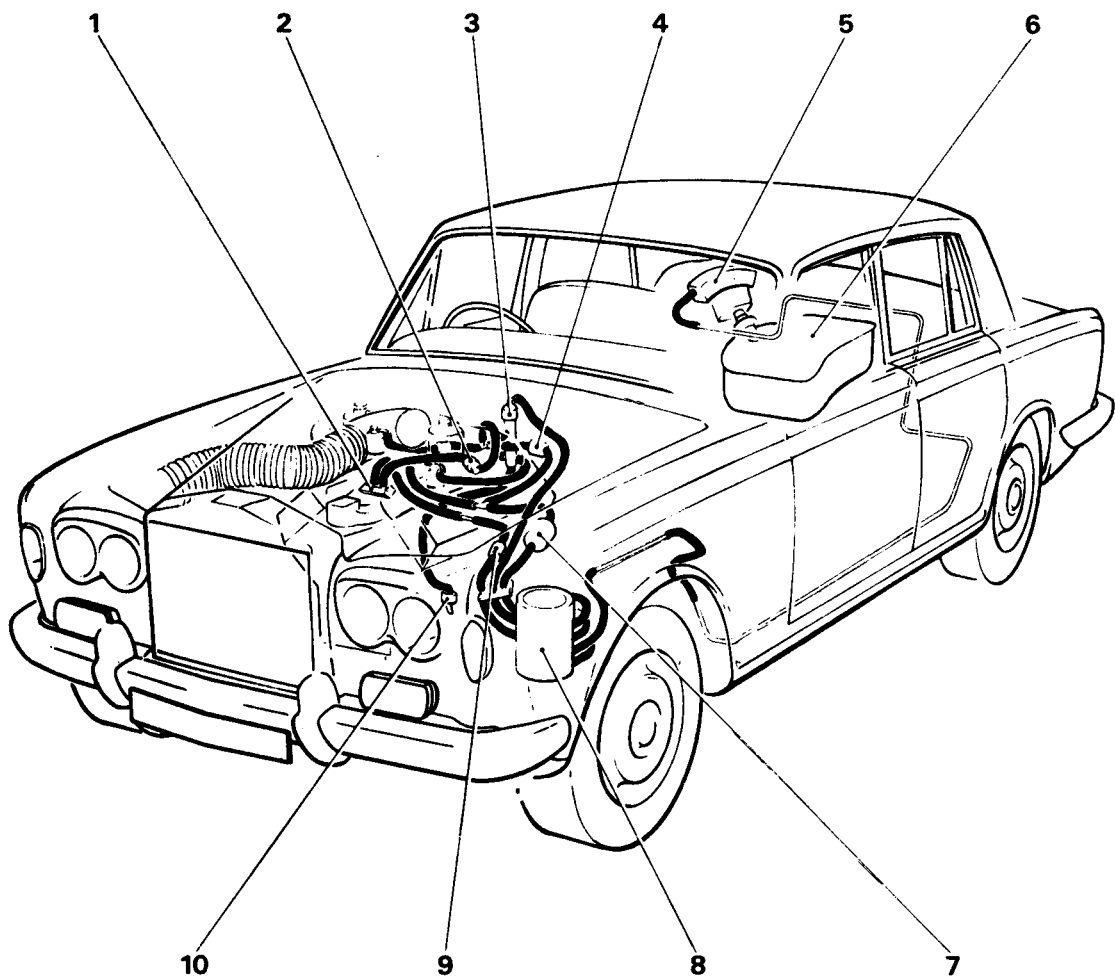

R 233

FIG. 8 FUEL EVAPORATION EMISSION CONTROL SYSTEM—GENERAL VIEW

- | | |
|-----------------------------|-------------------------------------|
| 1 Vacuum manifold | 6 Fuel tank assembly |
| 2 Anti 'run-on' solenoid | 7 Weakener filter |
| 3 Float chamber vent valve | 8 Evaporative loss control canister |
| 4 Weakener cut-off solenoid | 9 Purge line filter |
| 5 Fuel trap assembly | 10 Float chamber drain valve |

Chapter U

Fuel tank assembly

The fuel tank assembly consists of the fuel tank, expansion tank and fuel trap assembly (see Fig. 9).

The fuel tank is vented from three positions to a fuel trap assembly which is mounted above the fuel filler. One vent is from the fuel filler neck and the other two vents from the fuel tank.

The three vent lines join at a common junction block situated adjacent to the fuel filler neck, the main vent line then encircles the fuel tank before passing to the fuel trap assembly.

From the fuel trap, a vent line passes under the floor of the car to the evaporation loss control canister.

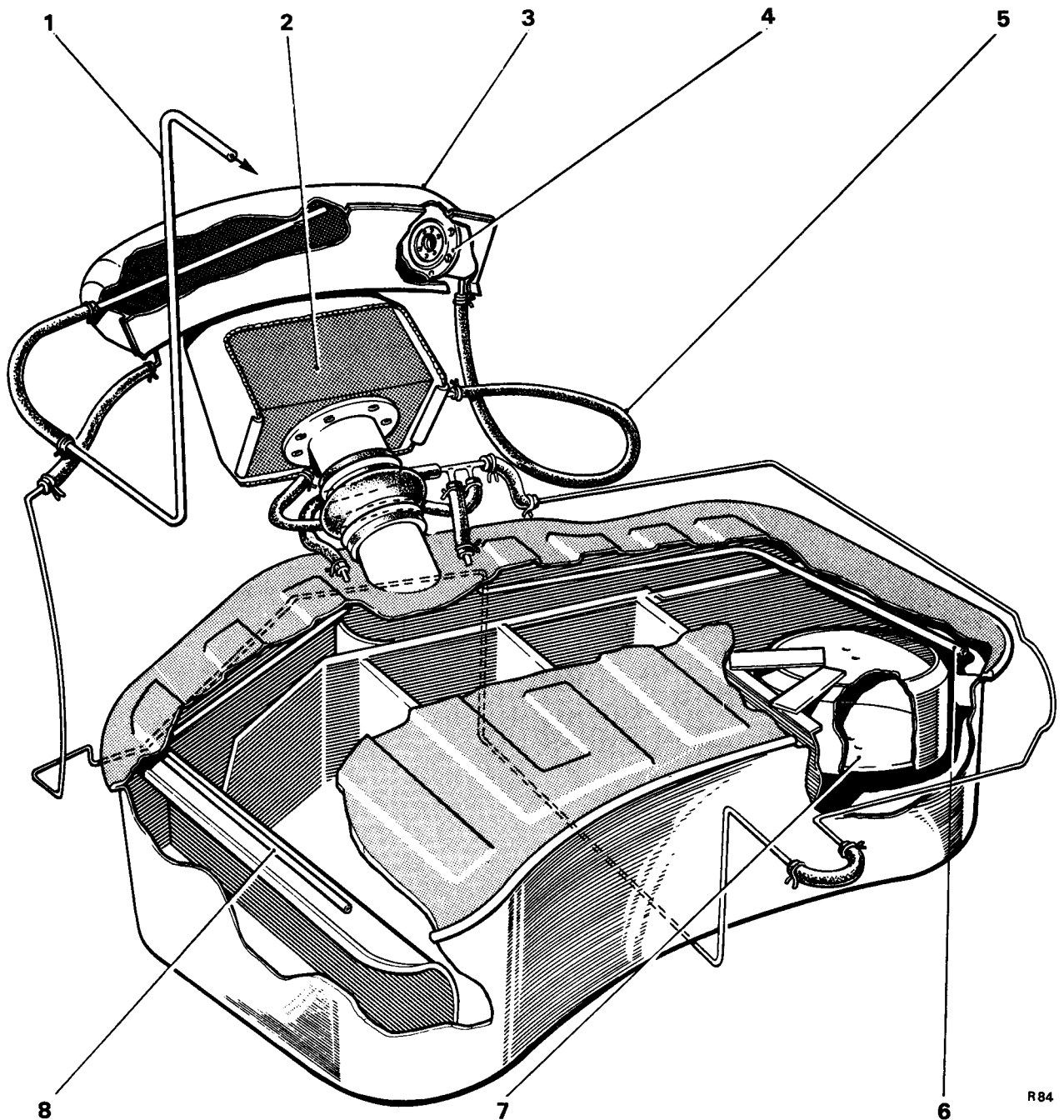

FIG. 9 FUEL EVAPORATION EMISSION CONTROL SYSTEM—FUEL TANK

1 Connection to
evaporation loss
control canister
2 Fuel filler box

3 Fuel trap
4 Combined relief
and vacuum valve

5 Valve vent
6 Vent pipe
7 Expansion tank
8 Vent pipe

Chapter U

Purge line

The purge line consists of a rubber hose, passing from the lowest connection on the canister through the valance junction piece to the vacuum manifold. Incorporated into this hose is the purge line filter and restrictor.

When the engine is running, air drawn through the canister filter and carbon picks up the stored fuel vapours and passes them via the hose, to the induction manifold. The restrictor in the line controls the flow rate at between 1,41 cu. m. per/hr. and 1,98 cu. m. per/hr. (50 cu. ft. per/hr. and 70 cu. ft. per/hr.) to maintain carburettor metering accuracy and the paper element line filter is fitted to prevent blockage of the restrictor.

Purge line filter—To remove

1. Using special pliers (RH 8090) remove the two steel retaining clips situated on either side of the unit.

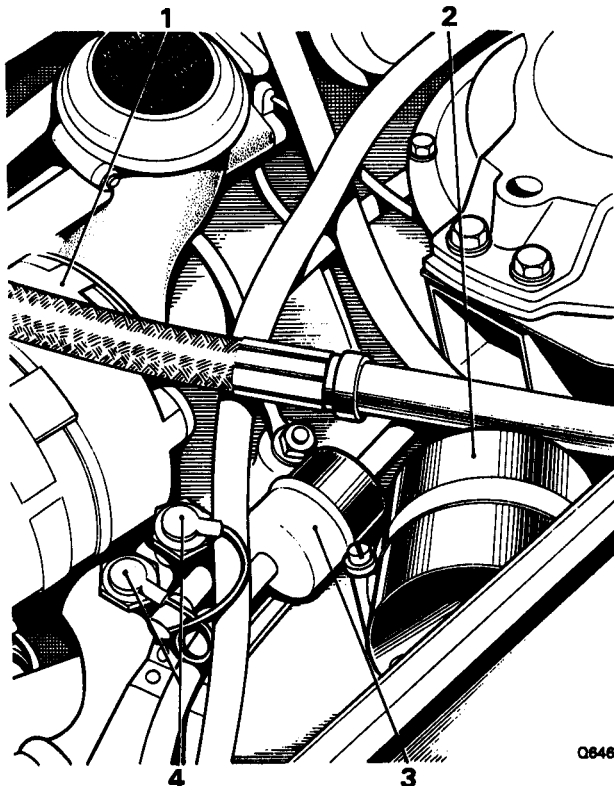

FIG. 10 POSITION OF MIXTURE WEAKENING DEVICE FILTER AND PURGE LINE FILTER

- 1 Alternator
- 2 Weakener filter
- 3 Purge line filter
- 4 Hydraulic fluid accumulator pressure switches

2. Slacken the setscrew which secures the nylon retaining clip.
3. Withdraw the component from the clip.

Purge line filter—To fit

Fit the purge line filter by reversing the procedure given for removal noting the following points.

1. Ensure that the rubber hoses are in a good condition and new hose retaining clips are used.

Purge flow rate—To check

Check the purge flow rate as follows.

1. Disconnect the hose from the engine side of the purge line filter and insert a flowmeter and stand assembly (RH 8725) into the line. The flowmeter is a rotameter type capable of measuring between 1,41 cu. m/hr. and 1,98 cu. m/hr. (50 cu. ft/hr. and 70 cu. ft/hr.). The pressure drop across the meter is not to exceed 5,08 cm. Hg. (2 in. Hg.).
2. Start and run the engine at idle speed, the flowmeter reading should be between 1,41 cu. m/hr. and 1,98 cu. m/hr. (50 cu. ft/hr. and 70 cu. ft/hr.).
3. If the flow is less than 1,41 cu. m/hr. (50 cu. ft/hr.) stop the engine and remove the purge line restrictor (see Fig. 5). Fit a piece of straight metal pipe with an internal bore larger than 4,76 mm. (0.187 in.), in the place of the restrictor.
4. Start and run the engine at idle speed, ensure that the flow is now in excess of 1,98 cu. m/hr. (70 cu. ft/hr.).
5. If the flow is less than 1,98 cu. m/hr. (70 cu. ft/hr.) check the following.
 - (i) an air leak in any of the vacuum hoses connected to the vacuum manifold (see Fig. 5).
 - (ii) a blockage in the vacuum manifold or any of the connecting hoses (see Fig. 5).
6. Rectify any air leaks or blockages found in the system. Repeat Operation 4.
7. Stop the engine and fit the purge line restrictor.
8. Start the engine and check the flow rate as detailed in Operation 2.
9. If the flow is still incorrect fit a new restrictor and again repeat Operation 2.
10. Stop the engine, remove the flowmeter assembly and connect the hoses.

For details of the remainder of the Fuel Evaporation Emission Control System see **Workshop Manual T.S.D. 2476—Chapter U (Part 2)**.

CRANKCASE EMISSION CONTROL SYSTEM

Crankcase emissions are controlled by a recirculatory closed breather system (*see Fig. 11*).

An insulated draught tube connects the crankcase via the oil filler which is fitted with a sealed cap, to the choke housing upstream of both the choke butterfly and the carburetters. A flame trap capsule containing three wire mesh discs is fitted in a housing at the crankcase end of the draught tube. Engine emission (blow-by) is drawn into the induction system via the draught tube, due to the depression in the choke housing.

Maintenance

1. The flame trap fitted to the breather pipe should be cleaned in the following manner, at the specified mileage.

2. Unscrew the setscrew securing the breather pipe connection to the oil filler pedestal; withdraw the connection from the pedestal (slight resistance may be felt due to the rubber 'O' ring connections).

3. Withdraw the connection from the pipe flange and collect the restrictor.

4. Wash the flame trap assembly in clean petrol, then dry with a high pressure air line. The flame trap assembly consists of 3 gauzes crimped together as shown in Figure 11.

5. To clean the adapter fitted to the choke housing, remove the single setscrew from the breather pipe end connection and detach the pipe.

6. Clean the adapter fitted to the choke housing and ensure that the holes in the adapter are clear.

7. Assembly of the flame trap and breather pipe is in the reverse order, ensuring that the 'O' rings are in good condition.

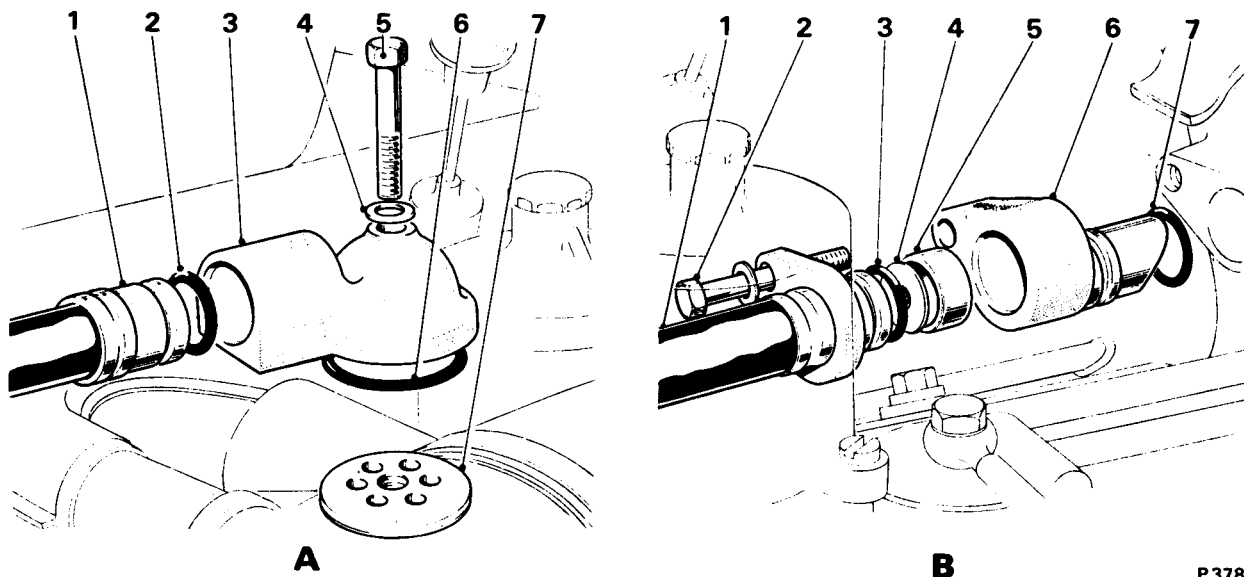

FIG. 11 EXPLODED VIEW OF CRANKCASE EMISSION CONTROL PIPE

Diagram A
 1 Pipe
 2 'O' ring
 3 Connection
 4 Washer
 5 Setscrew
 6 'O' ring
 7 Adapter

Diagram B
 1 Pipe
 2 Setscrew
 3 'O' ring
 4 Restrictor
 5 Flame trap
 6 Connection
 7 'O' ring

P378

Chapter U

EMISSION CONTROL SYSTEMS (ELECTRICAL COMPONENTS)

The electrical components covered by this section would normally appear in Chapter M — Electrical System, however, as they are only used in connection with the emission control systems it is thought more practical to include the information in this Chapter.

The components concerned are as follows.

- (i) The exhaust gas recirculation valve cut-in switch.
- (ii) The exhaust gas recirculation valve cut-off solenoid.

- (iii) The anti 'run-on' solenoid.
- (iv) The weakener cut-off solenoid valve.
- (v) The weakener cut-off solenoid switch.

For details of the remainder of the Emission Control Systems (Electrical Components) see **Workshop Manual T.S.D. 2476 — Chapter U (Part 2).**

THE CARBURETTERS AND AUTOMATIC CHOKE SYSTEM

CARBURETTER

Data

- Carburetters Two S.U. HD8 diaphragm type.
- Choke size 5.08 cm. (2.00 in.).
- Jet size—
spring loaded needle type 2.44 mm. (0.100 in.).
- Jet needle—
spring loaded type BDD
- Carburetter—
air valve piston spring Red/Blue.

CARBURETTER MIXTURE WEAKENING DEVICE

Description

In addition to the description given on pages U24 and U25, the following information is applicable.

Anti-diesel device (anti 'run-on' solenoid)

The use of low octane fuel causes the engine to 'diesel' (i.e. continue to run-on after the ignition has been switched off) when it is hot. To prevent this from happening an anti 'run-on' solenoid valve is fitted into the weakener signal line. When the ignition is switched off this valve opens and connects the weakening system to the induction manifold thus creating a high float chamber depression which cuts off the fuel supply.

Carburetter overrun valves

During overrun (i.e. when decelerating with the throttles closed), insufficient mixture is supplied to the engine to maintain satisfactory combustion. The overrun valves alleviate this condition by allowing some mixture to pass through the throttle plates (butterflies) at high inlet manifold depressions.

An overrun valve consists of a small disc retained in each throttle plate by a spring loaded plunger. Under normal conditions the disc is seated against the throttle plate. When the throttle is suddenly closed, the increased inlet manifold depression lifts the disc from its seating and allows a metered quantity of air/fuel mixture to pass through the throttle plate.

Chapter U

The action of the overrun valves maintains satisfactory combustion on overrun, thus reducing hydrocarbon emissions.

After the sudden closure of the throttles and as soon as the manifold depression falls, the overrun valve disc returns to its seat on the throttle plate.

Throttle damper

The throttle damper prevents rapid throttle closure which would suddenly drop the inlet manifold pressure causing vapourisation of fuel from the manifold walls and a sudden increase in mixture strength.

Temperature controlled air intake

To ensure rapid warm-up and improve control of the air/fuel ratio a temperature controlled air intake is fitted.

A vacuum operated blending valve attached to the air cleaner assembly is controlled by a thermal sensor in the air intake elbow. This valve blends hot air from a pick-up point (scoop) adjacent to the exhaust manifold with cold air from under the front wing; thus maintaining a constant temperature of the intake air as it enters the carburetters.

Throttle stop vacuum actuator assembly

The throttle stop vacuum actuator assembly is not fitted to cars produced to the 1976 specification.

Contra-rotating throttles—To fit and set (see Fig. 12)

1. Assemble 'A' bank and 'B' bank throttle levers (items 7 and 13) onto the carburetter spindles.
2. Fit the setting jig (RH 8880) into position on the throttle levers.
3. Fully close 'B' bank carburetter butterfly (item 8).
4. Tighten the pinch bolt securing 'B' bank throttle lever.
5. Fully close 'A' bank carburetter butterfly (item 3).
6. Tighten the pinch bolt securing 'A' bank throttle lever.
7. Fit the throttle spring (item 4) to the throttle levers.
8. Remove the setting jig from the throttle levers.

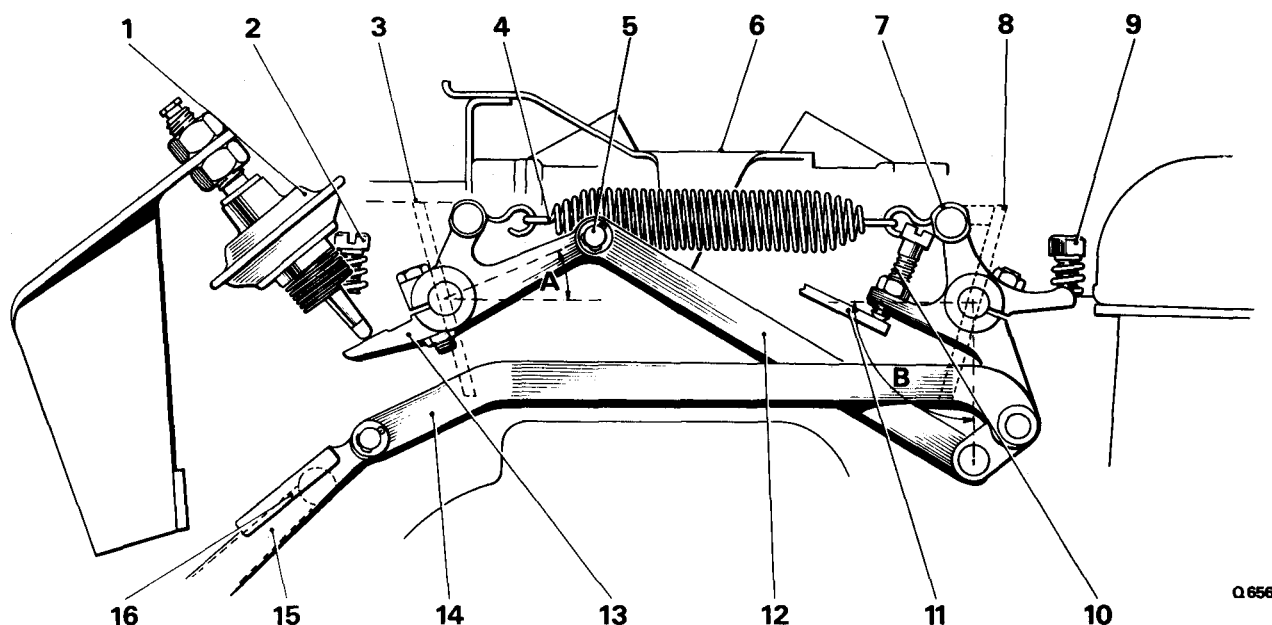
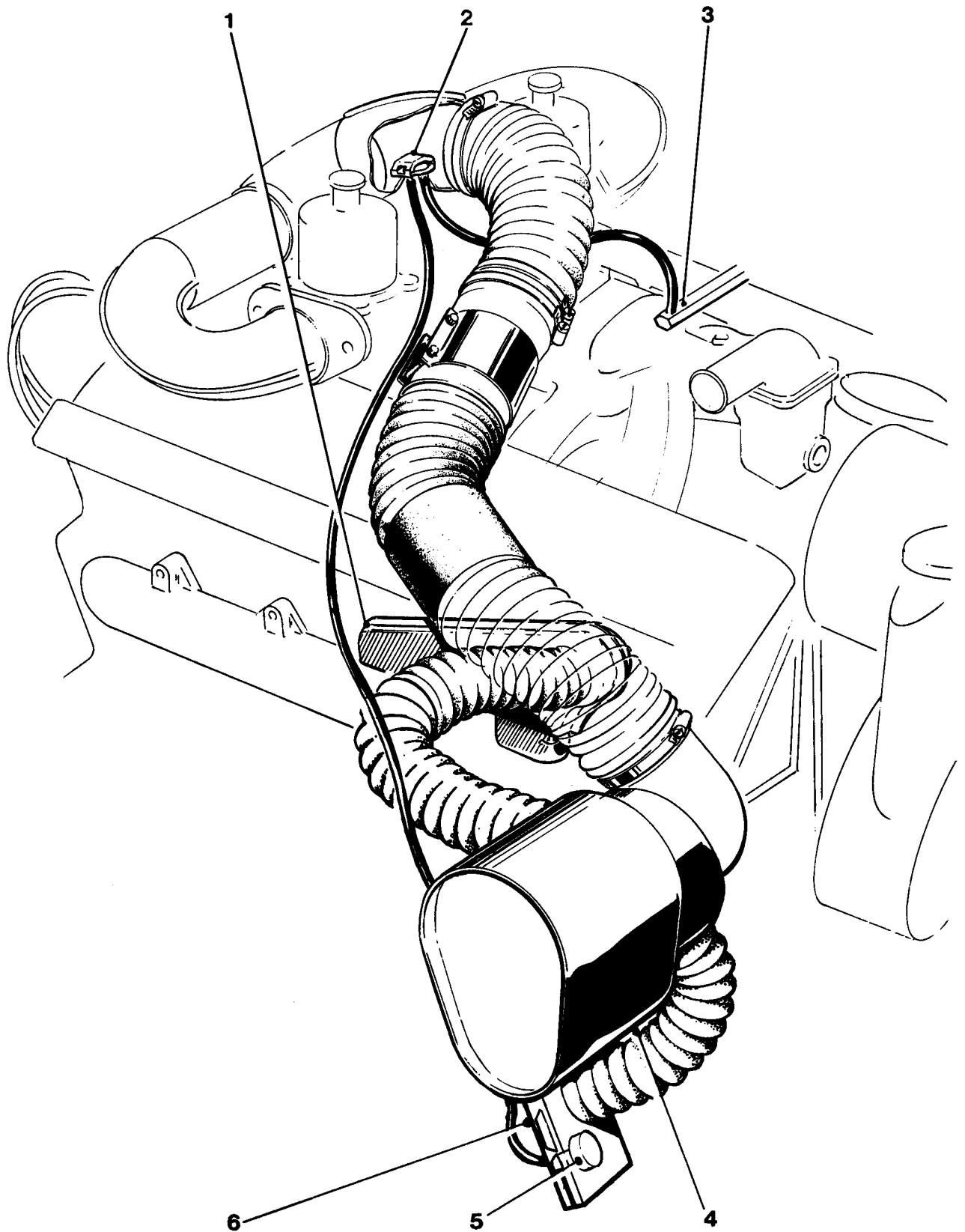

FIG. 12 CONTRA-ROTATING THROTTLE CONTROLS

- | | |
|---------------------------------------|--|
| A=Reference angle 22° | 8 'B' bank carburetter throttle plate |
| B=Reference angle 90° | 9 'B' bank carburetter volume screw |
| 1 Throttle damper | 10 Idle stop screw |
| 2 'A' bank carburetter volume screw | 11 Closed throttle bracket |
| 3 'A' bank carburetter throttle plate | 12 Cross link |
| 4 Throttle spring | 13 'A' bank carburetter throttle lever |
| 5 Eccentric throttle adjuster | 14 Drive link |
| 6 Throttle guard | 15 Front manifold shaft lever |
| 7 'B' bank carburetter throttle lever | 16 Rear manifold shaft lever |

Chapter U



Q 428

FIG. 13 TEMPERATURE CONTROLLED AIR INTAKE

- 1 Hot air scoop
- 2 Temperature sensor
- 3 Vacuum manifold

- 4 Air cleaner/silencer
- 5 Air blending valve
- 6 Cold air intake

Chapter U

9. Fit the cross link (*item 12*) and the eccentric throttle adjuster (*item 5*) onto the throttle levers, ensuring that both throttle butterflies are closed when adjusting and tightening the eccentric adjuster.

Note The eccentric pin should be set in the lowest position possible.

10. Ensure that the tang of the throttle guard (*item 6*) has a clearance of between 1,27 mm. (0.050 in.) and 1,78 mm. (0.070 in.) with the cross link and also that the tang does not foul the throttle spring. If necessary bend the tang to give these clearances.

11. Check that the throttle linkage moves freely.

12. Fit the idle stop screw (*item 10*) and adjust until it just contacts the stop bracket (*item 11*) with the throttle butterflies remaining in the closed throttle position.

13. Screw down the idle stop screw $\frac{1}{2}$ turn and tighten the lock-nut.

14. Screw both of the carburetter volume screws (*items 2 and 9*) fully in.

15. Fit the throttle damper (*item 1*) with the damper spindle compressed 4,75 mm. (0.187 in.) when throttle lever (*item 13*) is in the closed position. Ensure that the damper rod contacts the throttle lever centrally 5,1 mm. (0.20 in.) from the outer edge.

16. Connect the drive link (*item 14*) to the manifold shaft lever (*item 15*).

17. Operate the linkage to ensure free movement.

18. With the throttles in the closed position check that the 'A' bank control shaft to control rod lever (*item 16*) on the rear of the manifold shaft is in line with the front manifold shaft lever (*item 15*). Tighten the securing bolts on both levers.

19. Operate the mechanism; check for freedom of movement within the linkage and also clearance with the various engine components.

20. To set the remainder of the linkage from the control rod lever on the rear of the manifold shaft to the accelerator pedal refer to Chapter T—Part 2.

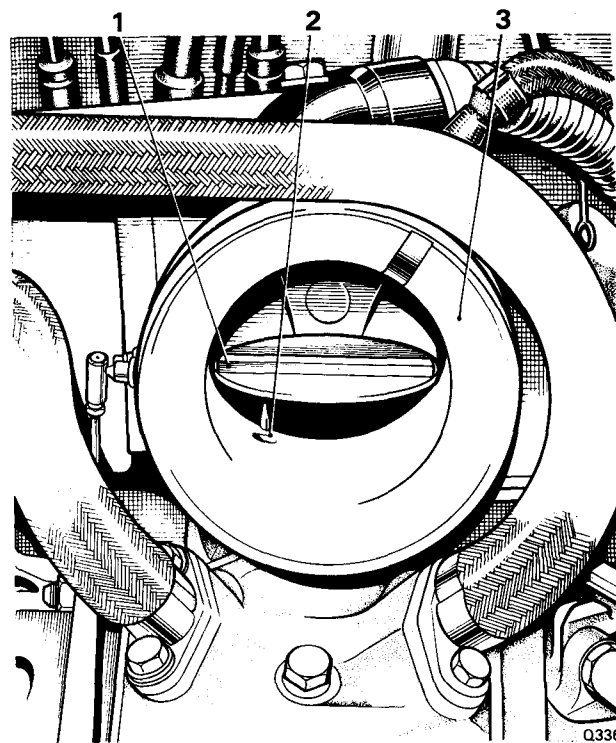

FIG.14 HOT IDLE MIXTURE COMPENSATOR FEED

- 1 Choke butterfly
- 2 Hot idle compensator feed
- 3 Butterfly housing

Throttle damper plunger—To set

1. Move the cold start 'fast-idle' to the off position.
2. Slacken both nuts securing the throttle damper to its bracket. Back off the nuts until they are well clear of the bracket.
3. Press the damper towards the 'A' bank throttle lever until the damper is fully compressed and the lever is just clear of the throttle stop screw.
4. Screw the lower securing nut until it is 0,63 mm. (0.025 in.) clear of the underside of the bracket. Release the damper and tighten the upper securing nut.
5. Ensure that the damper spindle is at the maximum possible radius, whilst maintaining adequate contact with the throttle lever pad. This can be achieved by adjusting the angle of the bracket.

Tuning procedure

The tuning procedure is given on page U32 with the following changes.

1. When blanking off the hot idle compensator feed drilling refer to Figure 14 in this Supplement.

Automatic choke stove pipe—To check

To check the stove pipe for any blockage, carry out the following procedure.

Chapter U

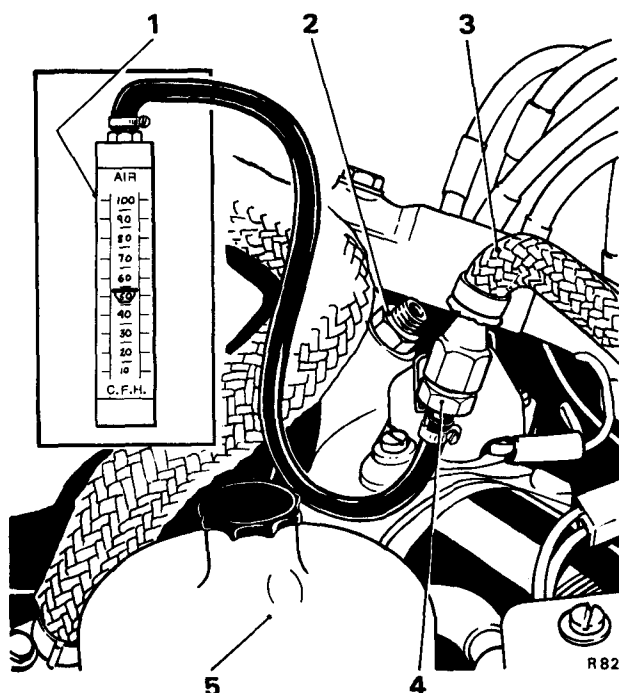

FIG. 15 CHECKING THE FLOW THROUGH THE CHOKE STOVE PIPE

- 1 Flowmeter
- 2 Choke stove pipe connection
- 3 Choke stove pipe
- 4 Adapter
- 5 'B' bank carburetter

1. Start the engine and run until normal operating temperature is attained.

2. Disconnect the union at the butterfly housing (see Fig. 15), and connect a flowmeter to the pipe via connector RH 8945. The flowmeter must be a rotameter type capable of measuring up to 2,83 cu. m/hr. (100 cu. ft/hr.).

3. Start the engine and run at idle speed (i.e. 600 r.p.m.); observe the flowmeter reading which should be between 1,41 cu. m/hr. and 1,55 cu. m/hr. (50 cu. ft/hr. and 55 cu. ft/hr.).

4. If the flowmeter reading is below 1,41 cu.m/hr. (50 cu. ft/hr.), stop the engine, remove the choke stove pipe and stove assembly to check for leaks.

5. If the flowmeter reading is above 1,55 cu. m/hr. (55 cu. ft/hr.) fit a new restrictor in the end of the choke bi-metal housing.

6. Fit the choke stove pipe and stove assembly, start the engine and again observe the flowmeter reading at idle speed.

7. Disconnect the flowmeter assembly and fit the choke stove pipe to the connection on the butterfly housing.

'Fast-idle' cam—To set

1. Fit the 'fast-idle' mechanism; do not tighten the 'fast-idle' lever clamping bolt.

2. Ensure that the 'fast-idle' adjustment screw is directly over the cam.

3. With the throttles closed, insert a 2,54 mm. (0.100 in.) diameter rod between the top of the 'fast-idle' cam and the boss under the 'fast-idle' adjustment screw. Tighten the clamping bolt on the 'fast-idle' lever.

4. Ensure that the throttles are closed; screw in the 'fast-idle' adjustment screw until it just makes contact with the top step of the 'fast-idle' cam.

5. Insert a 1,27 mm. (0.050 in.) diameter drill between the leading edge of the choke butterfly valve and the choke housing.

6. With the butterfly valve in this position, adjust the length of the butterfly rod so that the tip of the 'fast-idle' screw is in line with the start of the top step of the 'fast-idle' cam, (i.e. the position when the tip of the adjustment screw is about to fall from the top step to the bottom step of the cam).

Remove the 1,27 mm. (0.050 in.) diameter drill from the choke housing.

7. With the throttles closed and the choke partly open, adjust the 'fast-idle' adjustment screw to just contact the start or bottom step of the 'fast-idle' cam, screw in a further $\frac{1}{2}$ turn and tighten the lock-nut ensuring that the adjustment screw does not move.

Cold start 'fast-idle'—To set

1. Stop the engine and disconnect the solenoid to exhaust gas recirculation valve hose at the valve end. Blank the hose. Disconnect the signal hose to the distributor vacuum capsule at the capsule and blank off the hose. Remove the pressure tapping cap to vent the float chambers; open the throttles and close the choke butterfly against the bi-metal coil tension by means of the butterfly link lever, release the throttles. The 'fast-idle' adjusting screw will now be resting on the high step of the 'fast-idle' cam and the throttles are in the cold start position.

2. Start the engine and check the 'fast-idle' speed. If the speed is not between 1 900 r.p.m. and 2 100 r.p.m., stop the engine, open the throttles to gain access to the adjusting screw and adjust $\frac{1}{8}$ turn for each 100 r.p.m. outside the required speed.

3. Tighten the lock-nut and check the 'fast-idle' speed. If correct open the throttles to release the 'fast-idle' cam mechanism.

4. Remove the blank from the solenoid to the exhaust gas recirculation valve hose and connect the

Chapter U

hose to the exhaust gas recirculation valve. Fit the tapping cap to 'A' bank carburetter float chamber cover.

5. Remove the blank from the distributor advance vacuum signal hose and connect the hose to the capsule.

Float chamber depression—To check

Refer to Page U37 noting the following information.

- (i) The correct reading to be obtained on the manometer is 7,62 cm. (3.0 in.).
- (ii) **Operation 8** should read

8. Raise the engine speed slowly noting the manometer and tachometer readings. The maximum steady manometer reading should be obtained between 1 300 r.p.m. and 1 600 r.p.m. If the maximum depression occurs below 1 300 r.p.m. it is permissible to screw out the idle bleed screws on the carburetters by equal amounts (maximum 2.5 turns) to obtain this speed.

For details of the remainder of The Carburetters and Automatic Choke System see **Workshop Manual T.S.D. 2476 —Chapter U (Part 2).**

IGNITION SYSTEM, DISTRIBUTOR, IGNITION COIL AND SPARKING PLUGS

Data

Ignition timing . . . 4° B.T.D.C. (Static) 15° B.T.D.C. at 1 600 r.p.m. (stroboscopic) in Neutral with the vacuum advance disconnected and the feed hose blanked off. (Approach 1 600 r.p.m. from a higher speed).

Ignition control system

The ignition system utilises an Opus distributor (in which an oscillator pick-up and control unit replace the conventional contact breaker), a low inductance ignition coil and a ballast resistor. The control unit comprises an electronic oscillator, amplifier and power transistor.

A drum with eight ferrite rods (one per cylinder) moulded into the outer edge is mounted onto the distributor drive-shaft. As the drum rotates a voltage is created each time a ferrite rod passes the oscillator pick-up, this signal is then amplified and used to switch-off the normally conducting power transistor in the primary coil circuit thus inducing a high voltage in the secondary winding which is distributed to the sparking plugs in the normal manner.

In addition to the normal centrifugal advance mechanism the ignition distributor is fitted with a vacuum advance capsule. The E.G.R. gated orifice

vacuum signal is applied to the capsule to advance the ignition timing for part throttle fuel economy during open road cruising. The vacuum signal is inhibited by a solenoid valve until a predetermined coolant temperature is reached.

This ignition control system provides increased accuracy of timing and increased service life before maintenance is required.

Ignition—To time (using a stroboscope)

The ignition is timed on A1 cylinder which is located at the front left-hand side of the engine (viewed from the front of the car).

Note If the ignition timing is to be set, ensure that the sparking plugs are in good condition before running the engine; if they require cleaning or renewal the sparking plugs gap should be set to 0,76 mm. (0.030 in.).

1. To check the ignition timing commence by running the engine until normal operating temperature is attained and the choke 'fast-idle' is in the off position. Switch off the engine.

2. Connect a stroboscope and a tachometer to the engine as described in the instructions supplied with the respective equipment. Disconnect the feed hose at the vacuum advance capsule; blank off the feed hose.

Chapter U

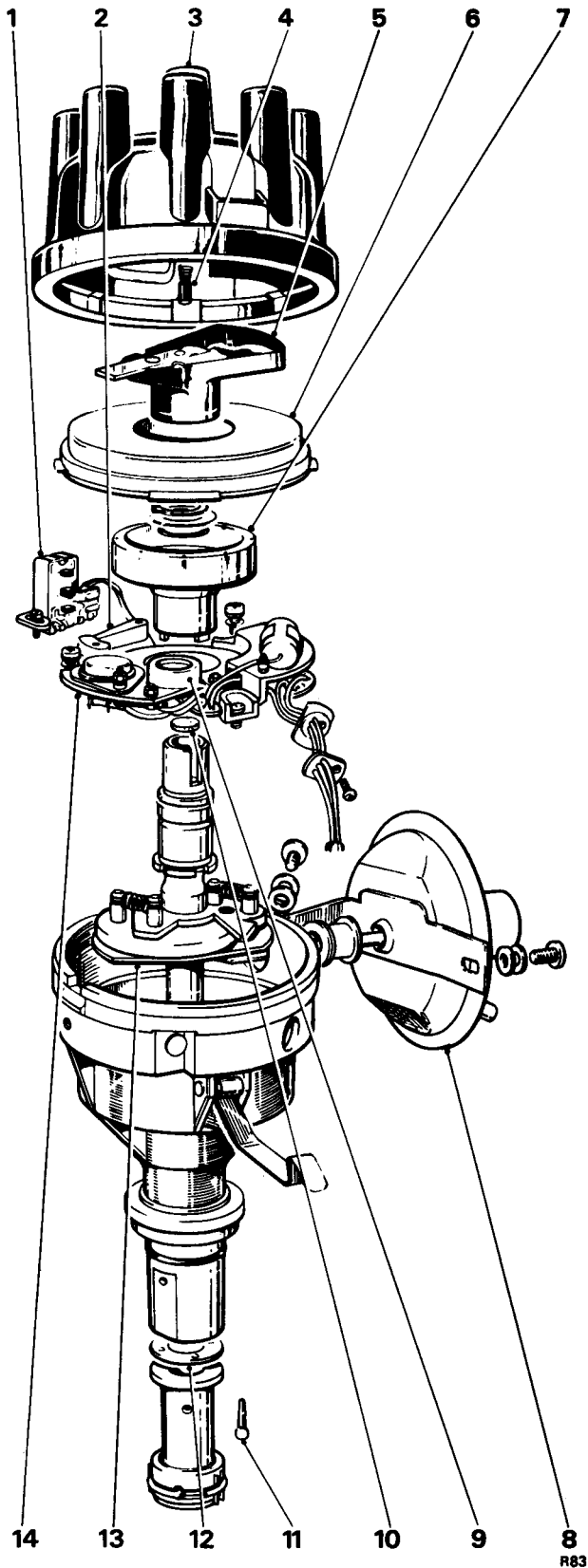

FIG. 16 EXPLODED VIEW OF DISTRIBUTOR

- 1 Pick-up module
- 2 Pick-up arm
- 3 Distributor cover/cap
- 4 High tension brush and spring
- 5 Rotor arm
- 6 Flash over shield (dust cover)
- 7 Timing rotor
- 8 Vacuum unit
- 9 Control unit
- 10 Lubrication pad
- 11 Driving dog and pin
- 12 Thrust washer
- 13 Automatic advance mechanism
- 14 Electronic module assembly

4. Direct the flashing light of the stroboscope onto the crankshaft damper timing marks and timing pointer; the pointer is positioned on the right-hand side of the crankshaft damper when viewed from the front of the engine.

5. If the timing pointer does not coincide with the 15° B.T.D.C. mark on the crankshaft damper adjust the ignition timing as follows.

6. Release the clamp screw on the distributor and rotate the head of the distributor in the appropriate direction until the correct timing is obtained. Clockwise rotation of the distributor head advances the ignition and conversely anti-clockwise rotation retards the ignition. After adjustment has been carried out tighten the clamp screw and again check to ensure that the timing has not altered whilst tightening the clamp screw.

7. Set the engine idle speed to 600 r.p.m.

8. Direct the flashing light of the stroboscope onto the crankshaft damper timing marks and timing pointer. Check that the ignition timing is approximately 4° B.T.D.C.

9. Stop the engine.

10. Disconnect the hose from the vacuum manifold to the purge line restrictor at the restrictor (*see Fig. 5*). Connect a suitable length of hose between this hose and the connection on the distributor vacuum capsule.

11. Start the engine and set the idle speed to 600 r.p.m.

12. Direct the flashing light of the stroboscope onto the crankshaft damper timing marks and timing pointer. Check that the ignition timing has advanced to approximately 14° B.T.D.C. If the ignition timing has not advanced, the distributor assembly is faulty.

13. Stop the engine.

14. Fit all hoses to their correct connections.

15. Start the engine and set the idle speed to 600 r.p.m.

16. Stop the engine and remove all the test equipment.

3. Start the engine and adjust the throttle stop screw to give an idle speed of 1 600 r.p.m. When setting the engine idle speed reduce from a higher speed to 1 600 r.p.m.

Chapter U

Setting the engine idle speed

Ensure that the engine is at normal operating temperature and that the choke 'fast-idle' is in the off position.

The air conditioning system must be switched off and a tachometer connected to the engine in accordance with the manufacturer's instructions.

1. Stop the engine, remove the air intake hose and blank off the hot idle compensator feed drilling (see Fig. 14). replace the air intake hose.

2. Start the engine and, if necessary, adjust the engine idle speed to 600 r.p.m. using the throttle stop screw; tighten the lock-nut.

3. Stop the engine and remove the air intake hose. Remove the blank from the hot idle compensator feed drilling and detach the tachometer and stroboscopic timing equipment (if fitted). Fit the air intake hose.

Sparking plugs

The sparking plugs approved for this car are Champion RN. 14.Y. Before fitting the plugs, set the gaps with the aid of a feeler gauge to 0,75 mm. (0.030 in.) and lightly smear the threads with 'Graphogen' grease.

LUBRICATION AND MAINTENANCE

The 'Essential' maintenance which is listed in the following schedules is the minimum servicing which must be carried out at the appropriate distance/time intervals in order to comply with the Rolls-Royce new car Warranty and the Australian Emission Regulations.

The 'Preventive' maintenance listed, is aimed at securing the maximum life and efficiency for the vehicle and will be carried out on request.

The schedules marked 'Regular' maintenance should be carried out either by the Owner, his chauffeur, or by a Distributor or Retailer.

REGULAR MAINTENANCE**Carburettors**

Monthly, check the oil level in the reservoirs of the automatic air valve dampers; top-up if necessary.

Engine

Weekly or every 800 km. (500 miles), whichever is the earlier, check the oil level by means of the dipstick; top-up if necessary.

Hydraulic reservoirs

Monthly, check the level of fluid in the reservoirs for the braking and automatic levelling systems; the engine should be run for 4 minutes before checking the fluid level. Top-up if necessary to the indicated level. If frequent topping-up is required check the hydraulic systems for leaks and rectify if necessary.

Lamp units

Weekly, check all lamp bulbs for correct operation and replace any faulty bulbs.

Radiator

Every 3 months, check the level of coolant in the radiator header tank; if necessary, top-up with the correct anti-freeze/water mixture or inhibited solution.

Tyres

Weekly, check the tyre pressures; adjust if necessary. Also check the spare wheel tyre pressure; adjust if necessary. Check the tread depth of all tyres and inspect the tyres for signs of damage.

Windscreen washer

Weekly, top-up the reservoir if necessary.

Chapter U

ESSENTIAL MAINTENANCE

INITIAL SERVICE

This service will be carried out by the Distributor/Retailer after the first 5 000 km. (3 000 miles) or 3 months whichever is the earlier.

Items marked * will be carried out free of charge.

INITIAL 5 000 km. (3 000 MILES) OR 3 MONTHS SERVICE WHICHEVER IS THE EARLIER

***Air injection pump**

Check belt tension and reset if necessary.

***Automatic choke**

Check the flow through the choke stove pipe and check for correct operation, rectify if necessary.

***Carburettors**

Check oil level in air valve dampers and if necessary top-up to correct level. Check tightness of float chamber covers. Check float chamber depression, rectify if necessary. Check and if necessary reset the idle speed. Check and if necessary reset the choke 'fast-idle' speed.

Engine

Change engine oil.

***Fuel evaporation emission control system**

Check the purge rate; this should be between 1,41 cu. m/hr. and 1,98 cu. m/hr. (50 cu. ft/hr. and 70 cu. ft/hr.) at 600 r.p.m. in Neutral. Pressure test the fuel tank and evaporation loss line and if necessary rectify any leaks.

***Ignition system**

Check ignition timing using stroboscope and adjust if necessary; the ignition timing should be 15° B.T.D.C. with the engine running at 1 600 r.p.m. the vacuum capsule disconnected and the feed hose blanked off.

Belt tension

Check the tension of all driving belts.

Engine cooling system

Tighten wormdrive clips of all coolant hoses.

Torque converter transmission

Check fluid level and top-up if necessary.

When checking the fluid level, avoid contact with the exhaust gas recirculation valve, heatshield and associated pipes as these components will be hot.

EVERY 5 000 KM. (3 000 MILES) OR 3 MONTHS WHICHEVER IS THE EARLIER

If the car is used for constant stop/start operation, change the engine oil.

EVERY 10 000 KM. (6 000 MILES) OR 6 MONTHS WHICHEVER IS THE EARLIER

Engine

Change engine oil and renew oil filter element.

Battery

Check the level of the electrolyte in the battery; if necessary top-up with distilled water.

Belt tension

Check the tension of all driving belts.

Chapter U

Brakes

Inspect footbrake and handbrake pad linings. When changing footbrake pads examine condition of dust excluders on calipers. Manually adjust handbrake pads. Inspect pipes and connections, rectify if necessary.

Fluid levels

Check all fluid levels.

Torque converter transmission

Check fluid levels and top-up if necessary.

When checking the fluid level, avoid contact with the exhaust gas recirculation valve, heatshield and associated pipes as these components will be **hot**.

**EVERY 20 000 KM. (12 000 MILES) OR
12 MONTHS SERVICE WHICHEVER
IS THE EARLIER**

Air injection pump

Check tension of pump pulley driving belt.

Air silencer

Fit a new paper filter element.

Carburettors

Top-up oil level in air valve dampers. Check tightness of float chamber covers. Check float chamber depression, rectify if necessary. Check and if necessary reset the idle speed. Check and if necessary, reset choke 'fast-idle' speed.

Crankcase emission control system

Remove and clean gauze flame traps in the crankcase breather tube. Clean the adapter in choke butterfly housing.

Engine

Change engine oil and renew oil filter element.

Fuel evaporation emission control system

Check the condition of the pipes and connections.

Ignition system

Fit new sparking plugs ensuring that the gaps are set to 0,75 mm. (0.030 in.).

Lubricate distributor spindle (shaft bearings) and automatic advance mechanism with engine oil.

Check the ignition timing using a stroboscope and adjust if necessary; the ignition timing should be 15° B.T.D.C. with the engine running at 1 600 r.p.m.. the vacuum capsule disconnected and the feed hose blanked off.

Battery

Check the level of the electrolyte in the battery; if necessary top-up with distilled water.

Belt tension

Check the tension of all driving belts.

Brakes

Inspect footbrake and handbrake pad linings. When changing footbrake pads examine condition of dust excluders on calipers. Manually adjust handbrake pads. Inspect pipes and connections, rectify if necessary.

Final drive unit

Check oil level and top-up if necessary.

Fluid levels

Check all fluid levels.

Front suspension

The front suspension ball joints are sealed for life and no maintenance is required until renewal is necessary or the ball joint rubber covers are damaged. Inspect the rubber covers on the front suspension ball joints; if the covers are found to be damaged new joints and covers should be fitted.

Chapter U

Steering ball joints

Lubricate the six grease nipples. Inspect the rubber covers on the ball joints; if the covers are found to be damaged the joints should be dismantled and new parts fitted as necessary.

Torque converter transmission

Renew transmission fluid.

When checking the fluid level, avoid contact with the exhaust gas recirculation valve, heatshield and associated pipes as these components will be **hot**.

Torque converter transmission

Check fluid level and top-up if necessary.

When checking the fluid level, avoid contact with the exhaust gas recirculation valve, heatshield and associated pipes as these components will be **hot**.

**EVERY 30 000 KM. (18 000 MILES) OR
18 MONTHS SERVICE WHICHEVER
IS THE EARLIER**

**EVERY 40 000 KM. (24 000 MILES) OR
2 YEARS SERVICE WHICHEVER
IS THE EARLIER**

Air injection pump

Check tension of pump pulley driving belt.

Engine

Change engine oil and renew oil filter element.

Air injection system

Check air injection system for leaks and correct functioning. Renew any defective items.

Battery

Check the level of the electrolyte in the battery; if necessary top-up with distilled water.

Air silencer

Fit a new paper filter element.

Belt tension

Check the tension of all driving belts.

Automatic choke

Check the air flow through the choke stove pipe and check the system for correct functioning.

Brakes

Inspect footbrake and handbrake pad linings. When changing footbrake pads examine condition of dust excluders on calipers. Manually adjust handbrake pads. Inspect pipes and connections, rectify if necessary.

Carburettors

Clean air valves. Remove inlet unions from the float chamber covers and fit new paper filter elements. Top-up oil level in air valve dampers. Check tightness of float chamber covers. Check float chamber depression. Check and if necessary, reset the idle speed. Check and if necessary, reset choke 'fast-idle' speed.

Fluid levels

Check all fluid levels.

Carburettor mixture weakening device

Renew air filter element for the carburettor mixture weakening device.

Chapter U

Brakes

Inspect footbrake and handbrake pad linings. When changing footbrake pads examine condition of dust excluders on calipers. Manually adjust handbrake pads. Inspect pipes and connections, rectify if necessary.

Fluid levels

Check all fluid levels.

Torque converter transmission

Check fluid levels and top-up if necessary.

When checking the fluid level, avoid contact with the exhaust gas recirculation valve, heatshield and associated pipes as these components will be **hot**.

**EVERY 20 000 KM. (12 000 MILES) OR
12 MONTHS SERVICE WHICHEVER
IS THE EARLIER**

Air injection pump

Check tension of pump pulley driving belt.

Air silencer

Fit a new paper filter element.

Carburettors

Top-up oil level in air valve dampers. Check tightness of float chamber covers. Check float chamber depression, rectify if necessary. Check and if necessary reset the idle speed. Check and if necessary, reset choke 'fast-idle' speed.

Crankcase emission control system

Remove and clean gauze flame traps in the crankcase breather tube. Clean the adapter in choke butterfly housing.

Engine

Change engine oil and renew oil filter element.

Fuel evaporation emission control system

Check the condition of the pipes and connections.

Ignition system

Fit new sparking plugs ensuring that the gaps are set to 0,75 mm. (0.030 in.).

Lubricate distributor spindle (shaft bearings) and automatic advance mechanism with engine oil.

Check the ignition timing using a stroboscope and adjust if necessary; the ignition timing should be 15° B.T.D.C. with the engine running at 1 600 r.p.m., the vacuum capsule disconnected and the feed hose blanked off.

Battery

Check the level of the electrolyte in the battery; if necessary top-up with distilled water.

Belt tension

Check the tension of all driving belts.

Brakes

Inspect footbrake and handbrake pad linings. When changing footbrake pads examine condition of dust excluders on calipers. Manually adjust handbrake pads. Inspect pipes and connections, rectify if necessary.

Final drive unit

Check oil level and top-up if necessary.

Fluid levels

Check all fluid levels.

Front suspension

The front suspension ball joints are sealed for life and no maintenance is required until renewal is necessary or the ball joint rubber covers are damaged. Inspect the rubber covers on the front suspension ball joints; if the covers are found to be damaged new joints and covers should be fitted.

Chapter U

Steering ball joints

Lubricate the six grease nipples. Inspect the rubber covers on the ball joints; if the covers are found to be damaged the joints should be dismantled and new parts fitted as necessary.

Torque converter transmission

Renew transmission fluid.

When checking the fluid level, avoid contact with the exhaust gas recirculation valve, heatshield and associated pipes as these components will be **hot**.

Torque converter transmission

Check fluid level and top-up if necessary.

When checking the fluid level, avoid contact with the exhaust gas recirculation valve, heatshield and associated pipes as these components will be **hot**.

**EVERY 30 000 KM. (18 000 MILES) OR
18 MONTHS SERVICE WHICHEVER
IS THE EARLIER**

**EVERY 40 000 KM. (24 000 MILES) OR
2 YEARS SERVICE WHICHEVER
IS THE EARLIER**

Engine

Change engine oil and renew oil filter element.

Air injection system

Check air injection system for leaks and correct functioning. Renew any defective items.

Battery

Check the level of the electrolyte in the battery; if necessary top-up with distilled water.

Air silencer

Fit a new paper filter element.

Belt tension

Check the tension of all driving belts.

Automatic choke

Check the air flow through the choke stove pipe and check the system for correct functioning.

Brakes

Inspect footbrake and handbrake pad linings. When changing footbrake pads examine condition of dust excluders on calipers. Manually adjust handbrake pads. Inspect pipes and connections, rectify if necessary.

Carburettors

Clean air valves. Remove inlet unions from the float chamber covers and fit new paper filter elements. Top-up oil level in air valve dampers. Check tightness of float chamber covers. Check float chamber depression. Check and if necessary, reset the idle speed. Check and if necessary, reset choke 'fast-idle' speed.

Fluid levels

Check all fluid levels.

Carburettor mixture weakening device

Renew air filter element for the carburettor mixture weakening device.

Chapter U

Crankcase emission control system

Remove and clean gauze flame traps in crankcase breather tube. Clean the adapter in choke butterfly housing.

Engine

Change engine oil and renew oil filter element.

Engine cooling system

Fit a new engine coolant thermostat and heater tap feed hose. Check the condition of all coolant hoses; fit new hoses as necessary.

Fuel evaporation emission control system

Renew the foam filter element in the evaporation loss control canister. Check the purge rate; this should be between 1,41 cu. m/hr. and 1,98 cu. m/hr. (50 cu.ft/hr. and 70 cu. ft/hr.) at 600 r.p.m. in Neutral. Renew the purge line filter if necessary.

Ignition system

Fit new sparking plugs ensuring that the gaps are set to 0,75 mm. (0.030 in.).

Lubricate distributor spindle (shaft bearings) and automatic advance mechanism with engine oil.

Check the ignition timing using a stroboscope and adjust if necessary; the ignition timing should be 15° B.T.D.C. with the engine running at 1 600 r.p.m., the vacuum capsule disconnected and the feed hose blanked off. Check the vacuum advance mechanism.

Battery

Check the level of the electrolyte in the battery; if necessary top-up with distilled water.

Belt tension

Check the tension of all driving belts.

Brakes

Inspect footbrake and handbrake pad linings. When changing footbrake pads examine condition of dust excluders on calipers. Manually adjust handbrake pads. Inspect pipes and connections, rectify if necessary.

Final drive unit

Change oil.

Fluid levels

Check all fluid levels.

Front suspension

The front suspension ball joints are sealed for life and no maintenance is required until renewal is necessary or the ball joint rubber covers are damaged. Inspect the rubber covers on the front suspension ball joints; if the covers are found to be damaged new joints and covers should be fitted.

Fuel pumps

Remove the fuel pumps and check for pumping efficiency, fit new pumps if necessary.

Hydraulic systems

Completely drain the fluid from the hydraulic circuits. Thoroughly clean the brake fluid reservoirs and sight glasses, ensure that no foreign matter enters the systems. Fill the hydraulic systems with new approved fluid: Bleed the brakes and height control systems.

Rear wheel drive-shafts

Lubricate the rear wheel drive-shaft outer universal couplings with an approved grease.

Steering ball joints

Lubricate the six grease nipples. Inspect the rubber covers on the ball joints; if the covers are found to be damaged the joints should be dismantled and new parts fitted as necessary.

Torque converter transmission

Change transmission fluid.

Fit a new intake strainer.

When checking the fluid level, avoid contact with the exhaust gas recirculation valve, heatshield and associated pipes as these components will be hot.

Chapter U**SERVICING AFTER 40 000 KM.
(24 000 MILES) OR 2 YEARS
WHICHEVER IS THE EARLIER**

After 40 000 km. (24 000 miles) or 2 years, servicing is still due at the following intervals.

**50 000 KM. (30 000 MILES)
OR 2½ YEARS
WHICHEVER IS THE EARLIER**

Carry out the 10 000 km. (6 000 miles) service.

**60 000 KM. (36 000 MILES)
OR 3 YEARS
WHICHEVER IS THE EARLIER**

Carry out the 20 000 km. (12 000 miles) service.

**70 000 KM. (42 000 MILES)
OR 3½ YEARS
WHICHEVER IS THE EARLIER**

Carry out the 10 000 km. (6 000 miles) service.

**80 000 KM. (48 000 MILES)
OR 4 YEARS
WHICHEVER IS THE EARLIER**

Carry out the 40 000 km. (24 000 miles) service and in addition the following operation.

Exhaust gas recirculation system

Remove and clean the exhaust gas recirculation valve and feed pipes. Clean the orifices in the carburetter 'Tee' piece. Check the exhaust gas recirculation valve for correct operation.

PREVENTIVE MAINTENANCE**INITIAL SERVICE**

This service should be carried out by the Distributor/ Retailer after the first 5 000 km. (3 000 miles) or 3 months whichever is the earlier.

Steering pump

Check the oil level in the reservoir; top-up if necessary.

Test

Road test the car for satisfactory performance.

**EVERY 10 000 KM. (6 000 MILES)
OR 6 MONTHS
WHICHEVER IS THE EARLIER****Carburetters**

Check the oil level in the air valve dampers and top-up if necessary.

Control linkages

Apply a few drops of engine oil to the accelerator linkage and to the gear range selector controls adjacent to the transmission casing.

Electrical system

Check all interior lamps, exterior lamps, instruments, warning lamps and devices for correct operation. rectify as necessary.

Handbrake

Lubricate the pivot pins and pulleys in the handbrake system with approved grease.

Tyres

Check the tread depth of all the tyres, inspect all tyres for signs of damage. Check all tyre pressures when cold, adjust if necessary.

Note Include the spare tyre.

Test

Road test the car for satisfactory performance.

Chapter U

**EVERY 20 000 KM. (12 000 MILES)
OR 12 MONTHS
WHICHEVER IS THE EARLIER****Control linkage**

Apply a few drops of engine oil to the accelerator linkage and to the gear range selector controls adjacent to the transmission casing.

Handbrake

Lubricate the pivot pins and pulleys in the handbrake system with approved grease.

Spare wheel

Lubricate the spare wheel lowering bolt and mechanism.

Electrical system

Check all interior lamps, exterior lamps, instruments, warning lamps and devices for correct operation, rectify as necessary.

Tyres

Check the tread depth of all the tyres, inspect all tyres for signs of damage. Check all tyre pressures when cold, adjust if necessary.

Note Include the spare tyre.

Test

Road test the car for satisfactory performance.

**EVERY 30 000 KM. (18 000 MILES)
OR 18 MONTHS
WHICHEVER IS THE EARLIER****Carburettors**

Check the oil level in the air valve dampers and top-up if necessary.

Control linkages

Apply a few drops of engine oil to the accelerator linkage and to the gear range selector controls adjacent to the transmission casing.

Electrical system

Check all interior lamps, exterior lamps, instruments, warning lamps and devices for correct operation, rectify as necessary.

Handbrake

Lubricate the pivot pins and pulleys in the handbrake system with approved grease.

Tyres

Check the tread depth of all tyres, inspect all tyres for signs of damage. Check all tyre pressures when cold, adjust if necessary.

Note Include the spare tyre.

Test

Road test the car for satisfactory performance.

**EVERY 40 000 KM. (24 000 MILES)
OR 2 YEARS
WHICHEVER IS THE EARLIER****Control linkage**

Apply a few drops of engine oil to the accelerator linkage and to the gear range selector controls adjacent to the transmission casing.

Electrical system

Check all interior lamps, exterior lamps, instruments, warning lamps and devices for correct operation, rectify as necessary.

Fuel filter

Renew the main line filter element and clean the filter bowl.

Fuel tank

Slacken the drain plug one or two turns and allow any accumulated water to drain away. Tighten the drain plug.

Height control mechanism

Disconnect the control valve linkage ball joints. Clean, grease and refit the ball joints.

Chapter U

Handbrake

Lubricate the pivot pins and pulleys in the handbrake system with approved grease.

Spare wheel

Lubricate the spare wheel lowering bolt and mechanism.

Tyres

Check the tread depth of all tyres, inspect all tyres for signs of damage. Check all tyre pressures when cold, adjust if necessary.

Note Include the spare tyre.

Test

Road test the car for satisfactory performance.

SERVICING AFTER 40 000 KM. (24 000 MILES) OR 2 YEARS WHICHEVER IS THE EARLIER

After 40 000 km. (24 000 miles) or 2 years, servicing is still due at the following intervals.

50 000 KM. (30 000 MILES) OR 2½ YEARS WHICHEVER IS THE EARLIER

Carry out the 10 000 km. (6 000 miles) service.

60 000 KM. (36 000 MILES) OR 3 YEARS WHICHEVER IS THE EARLIER

Carry out the 20 000 km. (12 000 miles) service.

70 000 KM. (42 000 MILES) OR 3½ YEARS WHICHEVER IS THE EARLIER

Carry out the 10 000 km. (6 000 miles) service.

80 000 KM. (48 000 MILES) OR 4 YEARS WHICHEVER IS THE EARLIER

Carry out the 40 000 km. (24 000 miles) service.

SEASONAL SCHEDULES

EVERY 12 MONTHS

Air conditioning system

Ensure that the foam filter element fitted to the scuttle intake grille is free from obstruction. On Long Wheelbase cars fitted with a centre division, check that the foam filter element fitted to the intake grille in the rear decking panel is free from obstruction.

Body

Check that the body drain holes are free from foreign matter.

Engine cooling system

Drain the coolant from the radiator and the engine crankcase. Clean any debris from the surfaces of the refrigeration condenser and radiator matrices by reverse flushing with a hose. This should be carried out just prior to the Autumn. Fill the system with the correct anti-freeze mixture (*refer to Chapter L—Engine Cooling System of this Workshop Manual T.S.D. 2476 and the latest Service Bulletin*).

EVERY 2 YEARS

In addition to the 12 monthly schedule, carry out the following.

Engine cooling system

Drain the coolant from the radiator and engine crankcase. Thoroughly reverse flush the coolant passages with a continuous flow of water. Change the coolant hoses where necessary. Fill the system with the correct anti-freeze mixture.

SERVICE RECOMMENDATIONS

80 000 KM. (48 000 MILES)

At this mileage and under normal motoring conditions it is recommended that the following servicing is carried out.

Chapter U**Hydraulic systems**

Renew the front and rear accumulator to frame connector block hoses.

Examine the sub-frame to brake caliper hoses for chafing or surface cracking; renew if necessary.

Fuel system

Fit a new convoluted rubber hose between the fuel filler head and fuel tank assembly. Examine all flexible fuel pipes and renew any which show signs of deterioration.

160 000 KM. (96 000 MILES)

At this mileage and under normal motoring conditions it is recommended that the following servicing is carried out.

Hydraulic systems

Renew all the flexible hoses to the braking systems and the automatic height control system. Fit new seals to the disc brake calipers and the deceleration conscious pressure limiting valve.

SPECIAL PRECAUTIONS

Should the car be used in very cold temperatures, drain the engine sump when thoroughly warm and also drain the carburetter air valve dampers. The engine sump and carburetter air valve dampers should then be filled with oil having the following viscosity.

For constant temperatures of between 0°C. and -23°C. (32°F. and -10°F.), use a 10W/30 grade oil.

For constant temperatures of -23°C. (-10°F.) and below, use a 5W/20 grade oil.

Chapter U

FAULT DIAGNOSIS

SYMPTOMS	POSSIBLE CAUSE
<p>1. Engine will not start. (Starter motor operating).</p>	<p>1. (a) Ignition circuit broken. (b) Failed anti 'run-on' solenoid or failure of electrical supply circuit. (c) Ignition system faulty. (d) Damaged or contaminated ignition high-tension circuit. (e) Fault in fuel feed line or fouled float chamber filters. (f) Faulty choke bi-metal coil. (g) Choke solenoid inoperative. (h) Faulty choke 'fast-idle' mechanism. (i) Air leak into induction system. (j) Faulty hot idle mixture compensator. (k) Weakening device filter blocked or blockage in rubber connecting hoses. (l) Faulty weakener cut-off solenoid or failure of electrical supply circuit. (m) Faulty weakening device control switch or failure of electrical supply circuit. (n) Dislodged venturi in weakener device. (o) Flooding of carburetter float chamber or jet. (p) Fouled carburetter float chamber or jet. (q) Exhaust gas recirculation valve failed.</p>
<p>2. Engine idles very roughly.</p>	<p>2. (a) Ignition system faulty. (b) Fouled sparking plugs. (c) Damaged or contaminated ignition high-tension circuit. (d) Air leak into induction system. (e) Faulty hot idle compensator. (f) Weakening device filter blocked or blockage in rubber connecting hoses. (g) Dislodged venturi in weakener device. (h) Badly worn or damaged carburetter control linkage. (i) Flooding of carburetter float chamber or jet. (j) Sticking carburetter piston. (k) Fouled carburetter float chamber or jet. (l) Air leak into exhaust gas recirculation vacuum control circuit. (m) Exhaust gas recirculation valve failed. (n) Faulty air diverter valve. (o) Incorrect operation of temperature controlled air intake system.</p>
<p>3. Engine stalls.</p>	<p>3. (a) Ignition circuit broken. (b) Failed anti 'run-on' solenoid or failure of electrical supply circuit. (c) Ignition system faulty. (d) Damaged or contaminated ignition high-tension circuit. (e) Fault in fuel feed line or fouled float chamber filters. (f) Air leak into induction system. (g) Faulty hot idle mixture compensator. (h) Weakening device filter blocked or blockage in rubber connecting hoses. (i) Dislodged venturi in weakening device. (j) Badly worn or damaged carburetter control linkage. (k) Flooding of carburetter float chamber or jet. (l) Sticking carburetter piston. (m) Fouled carburetter float chamber or jet. (n) Air leak into exhaust gas recirculation vacuum control circuit. (o) Exhaust gas recirculation valve failed. (p) Faulty air diverter valve.</p>

Chapter U

SYMPTOMS	POSSIBLE CAUSE
4. (i) Engine shows signs of power loss, evident at high speeds and loading. (ii) Engine misfires particularly on hard acceleration from low speed.	4. (a) Ignition system faulty. (b) Fouled sparking plugs. (c) Damaged or contaminated ignition high-tension circuit. (d) Fault in fuel feed line or fouled float chamber filters. (e) Choke system operation incorrect. (f) Sticking carburetter piston. (g) Fouled carburetter float chamber or jet. (h) Exhaust gas recirculation valve failed. (i) Failed exhaust gas recirculation valve cut-out solenoid or electrical supply circuit.
5. Engine hesitates or misfires under light load.	5. (a) Failed anti 'run-on' solenoid or failure of electrical supply circuit. (b) Ignition system faulty. (c) Fouled sparking plugs. (d) Damaged or contaminated ignition high-tension circuit. (e) Fault in fuel feed line or fouled float chamber filters. (f) Air leak into induction system. (g) Faulty hot idle mixture compensator. (h) Weakening device filter blocked or blockage in rubber connecting hoses. (i) Dislodged venturi in weakening device. (j) Flooding of carburetter float chamber or jet. (k) Sticking carburetter piston. (l) Fouled carburetter float chamber or jet. (m) Incorrect purge flow rate. (n) Exhaust gas recirculation valve failed. (o) Faulty air diverter valve. (p) Incorrect operation of temperature controlled air intake system.
6. Increase in fuel consumption.	6. (a) Ignition system faulty. (b) Faulty choke bi-metal coil. (c) Choke system operation incorrect. (d) Air leak into induction system. (e) Faulty hot idle mixture compensator. (f) Weakening device filter blocked or blockage in rubber connecting hoses. (g) Faulty weakener cut-off solenoid or failure of electrical supply circuit. (h) Faulty weakening device control switch or failure of electrical supply circuit. (i) Air leaks in mixture weakening system. (j) Flooding of carburetter float chamber or jet. (k) Sticking carburetter piston. (l) Incorrect purge flow rate. (m) Exhaust gas recirculation valve failed. (n) Faulty air diverter valve.
7. Decrease in fuel consumption.	7. (a) Air leaks in mixture weakening system. (b) Incorrect purge flow rate. (c) Faulty exhaust gas recirculation temperature control switch or failure of electrical supply circuit. (d) Air leak into exhaust gas recirculation vacuum control circuit. (e) Exhaust gas recirculation valve failed.
8. Engine 'backfires' on overrun.	8. (a) Ignition system faulty. (b) Air leak into induction system. (c) Exhaust gas recirculation valve failed.
9. Sudden increase in engine idle speed.	9. (a) Faulty choke 'fast-idle' mechanism. (b) Failed carburetter overrun valve.
10. Excessive noise from air injection pump or system.	10. (a) Faulty air diverter valve. (b) Faulty or damaged air injection pump.

Chapter U**WORKSHOP TOOLS**

<i>Tool Number</i>	<i>Description</i>
RH 8050	Spanner—Carburetter Jet Screw
RH 8087	Spanner—Weakener Cut-off Valve
RH 8089	Jet Centring Tool
RH 8090	Pliers—Wire Hose Clips
RH 8383	Positioning Tool—Throttle Spindle Seal
RH 8621	Adapter—Air Manifold to CO Meter
RH 8841	Dial Gauge—Carburetter Piston Lift
RH 8880	Setting Jig—Throttle Levers
RH 8945	Connector—Choke Stove Pipe

Chapter U - 1976 Running Change

Chapter U

Section U10

SUPPLEMENTS

No. 6 North America 1976

FUEL EVAPORATION EMISSION CONTROL SYSTEM

Printed in Great Britain

August 1976

T.S.D. 2476

The 1976 Running Change is now incorporated into the North American 1976 model year build specification and consists of a new fuel tank fitted at the forward end of the luggage compartment behind the carpet covered sealing panel (see Fig. 1).

The new design of fuel tank does not have a fuel trap assembly. Adequate expansion volume for the fuel is provided within the fuel tank and the combined pressure/vacuum relief valve is located in the fuel filler cap. The fuel tank is illustrated in Figure 2.

A rollover valve is incorporated in the vent line from the fuel tank to the evaporative loss control canister, the purpose of this valve is to prevent fuel from reaching the canister in the event of vehicle inversion.

The nominal capacity of the fuel tank is 22.5 U.S. galls.(18.5 Imp. galls.,85 litres).

Evaporation loss control canister

The evaporation loss control canister is mounted under the front left-hand wing (fender). It is a cylindrical container filled with activated carbon granules and has the following four connections.

- (i) The mixture weakening device
- (ii) The float chamber vent
- (iii) The fuel tank vent
- (iv) The purge line

The top of the container is open to atmosphere and contains a foam air filter element.

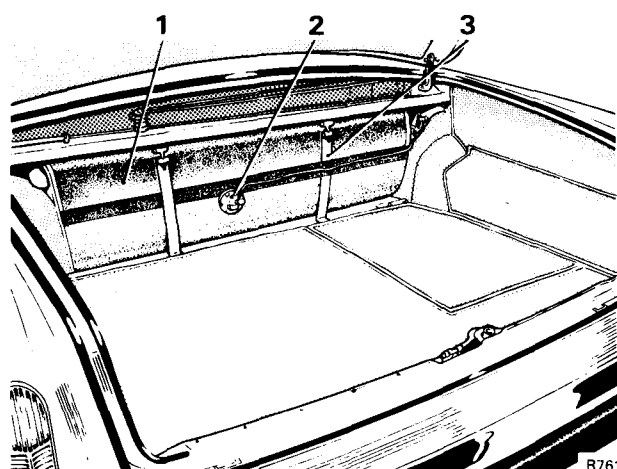

FIG. 1 POSITION OF FUEL TANK

- 1 Fuel tank
- 2 Gauge unit
- 3 Retaining strap

Chapter U - 1976 Running Change

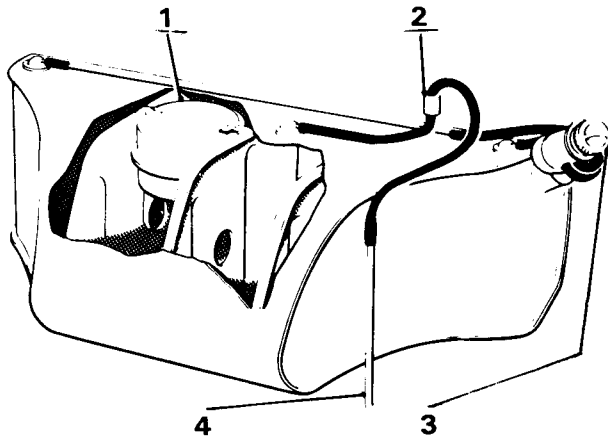

FIG. 2 FUEL TANK ASSEMBLY

- 1 Expansion tank and overfill limiter
- 2 Rollover valve
- 3 Fuel filler cap (incorporating combined pressure and vacuum relief valve)
- 4 Pipe to evaporation loss control canister

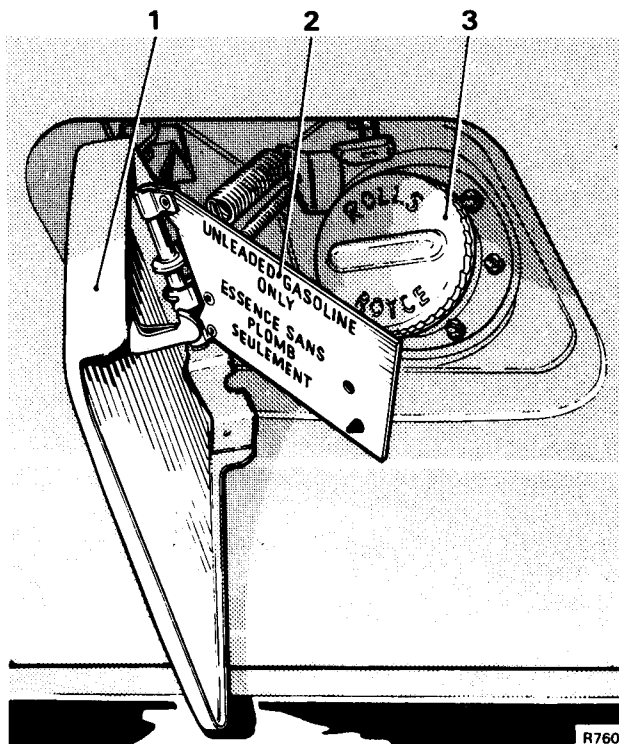

FIG. 3 FUEL FILLER (Saloon)

- 1 Filler door
- 2 Warning plate
- 3 Fuel filler cap

Fuel tank vent (see Fig. 2)

The fuel tank is vented via two connections to the filler neck which allows adequate venting of the tank when it is being filled.

A separate vapour line from the fuel tank passes via a rollover valve (situated on the top of the fuel tank), under the floor on the left-hand side of the car to the evaporation loss control canister.

The rollover valve prevents fuel from entering the evaporation emission control canister during harsh manoeuvres or in the event of vehicle inversion. Fuel vapour passes freely through the valve.

In the event of a blockage in the vapour line to the evaporation loss control canister, a combined pressure and vacuum relief valve in the fuel filler cap prevents any excessive build-up of pressure due to fuel vapourisation or depression as the fuel is consumed.

An expansion tank situated within the main fuel tank inhibits complete filling and thereby provides fuel expansion volume to cope with extreme temperature conditions.

Fuel tank—To remove

1. Disconnect the battery.
2. Drain the fuel from the tank; this is best achieved by disconnecting the fuel pipe from the tank to the filter at the filter end.
Fit the fuel pipe to the fuel filter.
3. Unscrew the four 'Poizdrive' screws situated across the carpet covered sealing panel. Remove the screws and collect the washers.
4. Withdraw the carpet covered seal panel to reveal the fuel tank assembly.
5. Unscrew the worm drive clip securing the rollover valve assembly to the crossmember. Detach the rollover valve from the crossmember.
6. Remove the crossmember (see Figs. 4 and 5); this is secured by a $\frac{7}{16}$ in. A/F nut, bolt and washer to the bottom of each luggage compartment lid hinge assembly.
7. Disconnect the three electrical cables from the fuel tank level gauge (see Fig. 5).
8. Remove the tape from the electrical loom by peeling it back from the fuel tank. Tape the electrical loom away from the vicinity of the fuel tank.
9. Unscrew the worm drive clips securing the three rubber vent hoses to their respective connections on the fuel tank (see Fig. 6); withdraw the hoses.
10. Unscrew the worm drive clip securing the rubber filler neck hose to the fuel tank (see Fig. 5); withdraw the hose.

Blank off the fuel tank connection.

Chapter U - 1976 Running Change

11. From beneath the car, unscrew and detach the fuel pipe. This connection is an olive and threaded union.

Blank off the fuel tank connection.

12. Unlock and unscrew the half-nut from each of the two tank retaining strap bolts (see Fig. 6).

13. Unscrew the full nut from each of the two tank retaining strap bolts (see Fig. 6).

14. Withdraw the bolts and collect the four bridge pieces from the end of the retaining straps (see Fig. 6).

15. Bend the retaining straps and carefully withdraw the fuel tank assembly.

Fuel tank—To fit

1. Sweep clean the forward end of the luggage compartment, between the road spring pots.

If blanking plugs, nuts, washers, etc., remain in this area when the fuel tank is fitted, they could become the cause of noise which may prove difficult to eradicate once the fuel tank is in position.

Also, ensure that the battery is disconnected and the usual standard workshop precautions carried out.

2. Ensure that the self-tapping screws that secure the pipe retaining clips beneath the car do not protrude to far into the luggage compartment. Extra long self-tapping screws could puncture the fuel tank.

3. Position the strips of 'Compriband' in position. Also fit the 'Compriband' pad around the hole in the luggage compartment floor.

The 'Compriband' and the two rubber blocks [that fit approximately 5,08 cm. (2.0 in.) above the luggage compartment floor on the panel dividing the compartment from the car interior] should be secured in position using an appropriate adhesive such as 'Dunlop S81'.

The position of all mounting strips are shown in Figure 7.

4. Fit the four fuel tank securing straps to the body (see Fig. 7). The two upper mountings are similar and are shown in Figure 7—inset A. The two lower mountings are different, the left-hand mounting is shown in Figure 7—inset B, where the bolt passes through the body and is retained by a nut. The right-hand mount is shown in Figure 7—inset C, where the bolt has a distance piece and screws directly into a threaded bush attached to the body.

5. Fit the 4,8 mm. ($\frac{3}{16}$ in.) internal diameter rubber hose to the metal pipe situated on the left-hand side of the luggage compartment, adjacent to the panel dividing the luggage compartment from the car interior. (see Fig. 5).

Temporarily attach the open end of the rubber hose high in the luggage compartment so that it will be above the fuel tank.

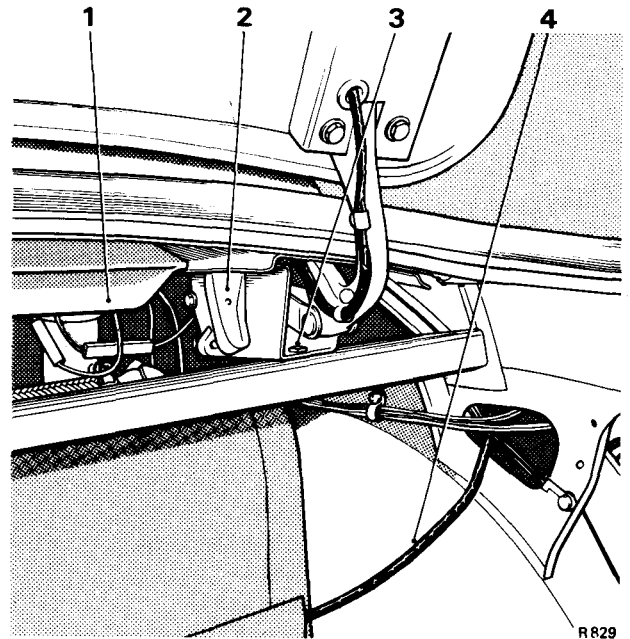

FIG. 4 LUGGAGE COMPARTMENT LID HINGE ASSEMBLY

- 1 Interior ventilation duct
- 2 Hinge assembly
- 3 Crossmember retaining bolt
- 4 Gauge unit loom

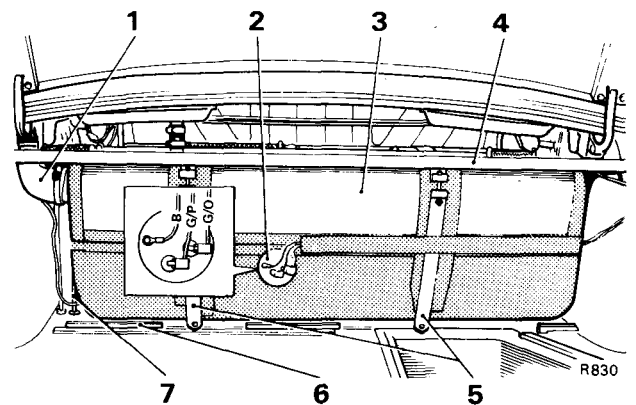

FIG. 5 FUEL TANK FITTINGS

- 1 Fuel filler hose
- 2 Gauge unit
- 3 Soundproofing panel
- 4 Crossmember
- 5 Securing straps
- 6 Carpet runner slots
- 7 Metal pipe (to evaporation loss control canister)

Chapter U - 1976 Running Change

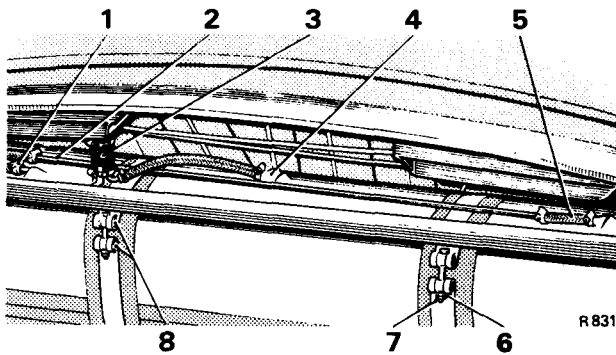

FIG. 6 FUEL TANK VENT CONNECTIONS

- 1 Vent-filler neck
- 2 Fuel tank vent metal pipe
- 3 Rollover valve
- 4 Vent - rollover valve
- 5 Vent - filler neck
- 6 Full nut
- 7 Half nut (locknut)
- 8 Bridge pieces

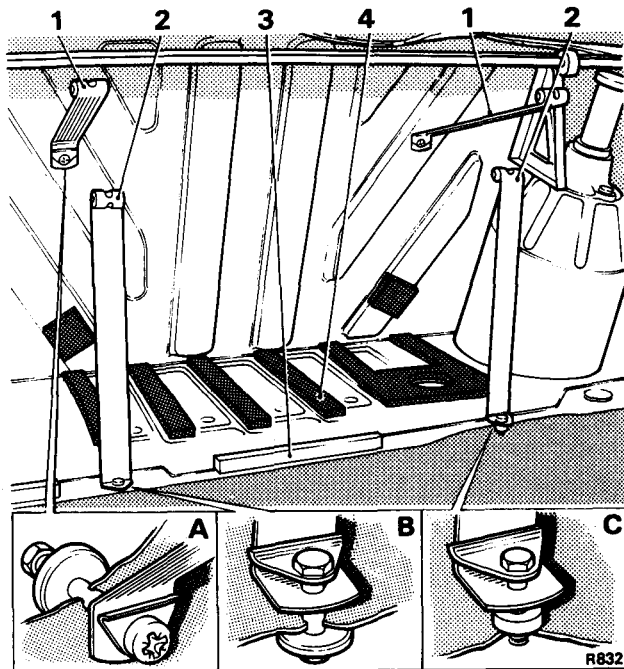

FIG. 7 LUGGAGE COMPARTMENT - FUEL TANK FITTINGS

- 1 Upper securing straps
- 2 Lower securing straps
- 3 Carpet runner slots
- 4 'Compriband' rubber

6. Fit the soundproofing panel to the fuel tank and secure in position with tape (see Fig. 5). In addition, fit two pieces of tape around the fuel tank so that the securing straps will sit on the tape when the tank is secured in position (see Fig. 5).

7. Bend the securing straps to enable the fuel tank to be fitted.

8. Fit the fuel tank into position, ensuring that the boss on the base of the tank fits into the hole in the luggage compartment floor.

9. Secure the fuel tank in position as follows (see Fig. 5).

10. Fit a bridge piece to the end of each securing strap and secure the fuel tank in position by fitting a long $\frac{7}{16}$ in. A/F bolt, downwards, through the upper and lower securing strap bridge pieces. Screw a full nut onto the bolt.

11. Repeat Operation 10 to the second set of securing straps.

12. Tighten the full nut of each set of securing straps and lock in position by fitting an additional half nut to each of the two bolts.

13. From beneath the car fit the fuel pipe to the fuel tank, this connection is provided by an olive and a threaded union.

14. Fit the rubber intake pipe to the fuel tank neck and secure the end of the hose with a worm drive clip.

15. Fit the two 8,0 mm. ($\frac{5}{16}$ in.) internal diameter rubber hoses of the fuel intake assembly to the fuel tank vents. One hose connects directly to the vent, whilst the second hose, connects to the vent on the other side of the fuel tank, via a metal pipe which is fitted across the top of the tank (see Fig. 6).

Secure the ends of the hoses with worm drive clips.

16. Fit the open end of the 4,8 mm. ($\frac{3}{16}$ in.) diameter hose referred to in Operation 5 to the top of the rollover valve assembly. Fit an 8,0 mm. ($\frac{5}{16}$ in.) internal diameter hose between the centre vent in the top of the fuel tank and the bottom connection of the rollover valve (see Fig. 6).

Secure the ends of the hose with worm drive clips.

17. Fit the crossmember (see Fig. 5), attaching it to the bottom bracket of each of the two luggage compartment lid hinge assemblies with a $\frac{7}{16}$ in. A/F bolt, washer and nut (see Fig. 4).

18. Locate the fuel gauge sender unit electrical loom situated above the right-hand rear wheel arch; there are three cables in the loom and these are coloured black, green/orange and green/purple.

Tape the cables across the fuel tank until they are adjacent to the fuel gauge sender unit, as shown in Figure 5.

19. Connect the cables to the fuel gauge sender unit as shown in the inset of Figure 5.

20. Locate the base of the carpet covered panel into the wooden runner slots (see Fig. 5) and

Chapter U - 1976 Running Change

secure the top of the panel with four 'Pozidrive' screws and washers to the crossmember.

21. Connect the battery.

Fuel filler—To remove (Saloon cars)

1. Disconnect the battery.
2. Unscrew and remove the four 'Pozidrive' screws situated across the carpet covered sealing panel at the forward end of the luggage compartment.
3. Withdraw the carpet covered seal panel to reveal the fuel tank assembly.
4. Unscrew the worm drive clips securing the two 8,0 mm. ($\frac{5}{16}$ in.) internal diameter rubber hoses to the two outer vents on the top of the fuel tank, one hose fits directly onto a vent while the other hose fits to a metal pipe which extends across the width of the fuel tank; withdraw the hoses.
5. Unscrew the worm drive clip securing the fuel inlet hose to the fuel tank; withdraw the hose and blank off the fuel tank inlet.
6. From inside the car remove the trim panel that covers the filler assembly, this is situated adjacent to the rear window.

On 4 door saloons (except Long Wheelbase Saloons with the small rear window) unscrew the two screws from the wood finisher fitted around the rear window. Carefully withdraw the trim panel to reveal the upper connection for the fuel filler.

7. Unscrew the worm drive clip securing the fuel filler hose to the fuel filler head. Withdraw the fuel filler neck assembly downwards into the luggage compartment.
8. Open the fuel filler flap; unscrew and remove the fuel filler cap.

9. Using a screwdriver, unscrew and remove the six screws securing the fuel filler head to the body, collect the washers from the retaining screws and withdraw the fuel filler head assembly.

Fuel filler—To fit (Saloon cars)

Fit the fuel filler assembly by reversing the procedure given for removal, noting the following.

1. When fitting the fuel filler head to the body, ensure that the restrictor is in its lowest position.

Fuel filler—To remove (Convertible cars)

1. Remove the carpet covered sealing panel from the forward end of the luggage compartment.
2. Locate the fuel filler neck assembly situated on the left-hand side of the fuel tank.
3. Disconnect the two rubber hoses from the outer vents on top of the fuel tank.
4. Unscrew the upper and lower worm drive clips from the fuel filler neck assembly, withdraw the assembly and blank off the fuel tank.
5. Open the fuel filler flap and unscrew the fuel filler cap.
6. Using a screwdriver, unscrew and remove the six screws securing the fuel filler head to the body, collect the washers from beneath the heads of the screws. Withdraw the assembly.

Fuel filler—To fit (Convertible cars)

Fit the fuel filler assembly by reversing the procedure given for removal.

Chapter U - 1976 Running Change

EMISSION CONTROL SYSTEMS (ELECTRICAL COMPONENTS)

Fuel gauge—Air cored

The fuel gauge fitted to these cars is an 'air cored' instrument. The gauge operates on a slightly different principle to its predecessors in that it does not have the iron core.

The main advantage of this new type of instrument is that it is effectively damped, this characteristic does mean however, that the engine oil sump level indications on the fuel gauge will not be instantaneous and operators are advised to keep the test button on the facia depressed for approximately 5 seconds until the gauge needle has stabilized.

In the past, the facia button mentioned also tested the engine overheat buzzer (with the low coolant warning lamp also being illuminated), however, this feature is no longer included in the test circuit.

Engine overheat

warning buzzer—To test

At the intervals specified in the Service Schedules the engine overheat warning buzzer should be tested for operation as follows.

1. Locate the warning buzzer sender unit situated on 'A' bank cylinder head, between the sparking plugs of cylinders A3 and A4.
2. Detach the 'Lucar' connection (green/purple cable).
3. Switch on the ignition, the buzzer should sound whenever the 'Lucar' connection (green/purple cable) is earthed.

THE CARBURETTORS AND AUTOMATIC CHOKE SYSTEM

Fuel cooler

A cooler is fitted into the fuel system and using the same refrigerant as the air conditioning system, cools the fuel before it enters the carburettor float chambers. The fuel cooler is situated adjacent to the refrigeration compressor

Fuel cooler—To remove

1. Discharge the refrigerant (*see Chapter C*).
2. Unscrew the two unions connecting the cooler to the fuel pipes.
3. Disconnect the refrigeration pipe from the front of the cooler.
4. Unscrew and remove the setscrew that secures the clamp plate to the rear face of the compressor.

5. Withdraw the clamp plate from the rear face of the compressor.

6. Unscrew and remove the cooler mounting setscrews situated at the forward end of the assembly; free the refrigeration pipes from the rear of the assembly. Withdraw the cooler.

Fuel cooler—To fit

To fit the fuel cooler reverse the procedure given for removal noting the following points.

1. Fit new rubber 'O' rings between the rear face of the compressor and the unions of the refrigeration pipes.
2. After fitting the cooler the full procedure of evacuation and sweeping must be carried out before the refrigeration system is charged, details are given in Chapter C.

Chapter U

Section U10

SUPPLEMENTS

No. 9 North America
1968-1976 (inclusive)

PROVISION OF ALTITUDE PERFORMANCE ADJUSTMENTS

Regulations concerning the provision of altitude performance adjustments, applying to all 'model years' from 1968 to 1981 inclusive, necessitate the fitting of new needles to the carburetters to improve the exhaust emissions.

These adjustments concern vehicles being operated at altitudes other than that for which the vehicle was originally certified.

High Altitude Areas are defined in the Federal Register - Volume 41 - Number 46 - Dated Monday, March 8th 1976 - as a County or Counties in the U.S.A. wholly located above 1 219 metres (4 000 feet).

These altitude performance adjustment instructions are applicable to all Rolls-Royce and Bentley vehicles manufactured for initial sale in North America (1968 - 1976 'model years' inclusive).

The following is a list of the kits available, applicable to the appropriate model year(s).

Kit Number	Model Year
RH 2819	1968
RH 2820	1969-1972 (inclusive)
RH 2821	1973
RH 2822	1974
RH 2823	1975-1976 (inclusive)

The kits consist of a pair of needles and an 'Update' label.

After the new needles have been fitted, the idle CO (carburetter mixture strength) will have to be checked and reset if necessary. Reference should be made to the appropriate 'model year' of Chapter U, for the relevant settings.

When the above work has been carried out, the Vehicle Emission Control Information Update label supplied with the kit, should be fitted under the bonnet **alongside** the existing emission control certification label, but must not be fitted to any part that can be easily detached from the vehicle.

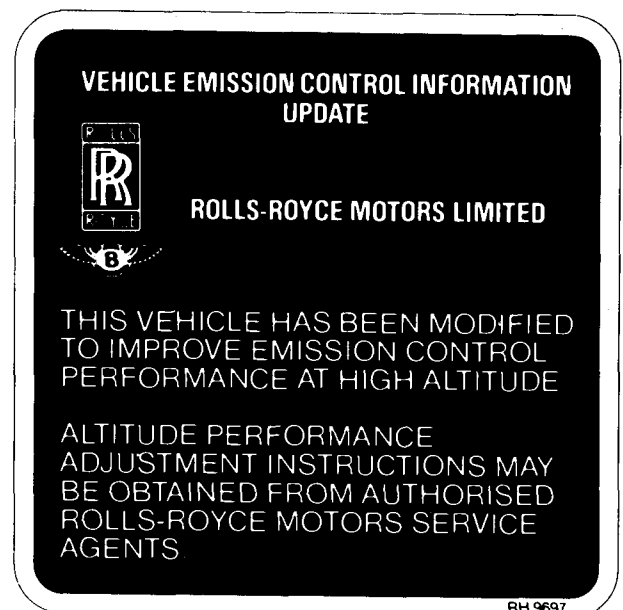

**VEHICLE EMISSION CONTROL
INFORMATION UPDATE LABEL**

Chapter U

Needles - To remove

1. Thoroughly clean the outside of the carburetter.
2. Mark the suction chamber and carburetter body with a pencil, to aid assembly.
3. Unscrew and remove the damper and washer.
4. Remove the suction chamber retaining screws and remove the chamber without tilting it.
5. Remove the piston spring.
6. Carefully lift out the piston and needle assembly. Empty the oil from the piston rod.
7. **Carburetters fitted with a fixed needle.**

Remove the needle locking screw and withdraw the needle. If it cannot easily be removed, first tap the needle inwards, then pull outwards.

Carburetters fitted with a spring loaded needle.

Remove the needle guide locking screw from the piston, then withdraw the needle assembly taking care not to bend the needle.

Withdraw the needle guide from the needle and remove the spring.

Needles - To fit

Carburetters fitted with a fixed needle

1. Fit the needle to the piston assembly. The shoulder or lower edge of the groove must be level with the lower face of the piston rod (see Fig. 1). Fit and tighten the locking screw.
2. Invert the suction chamber and spin the piston assembly to check for concentricity of the needle.

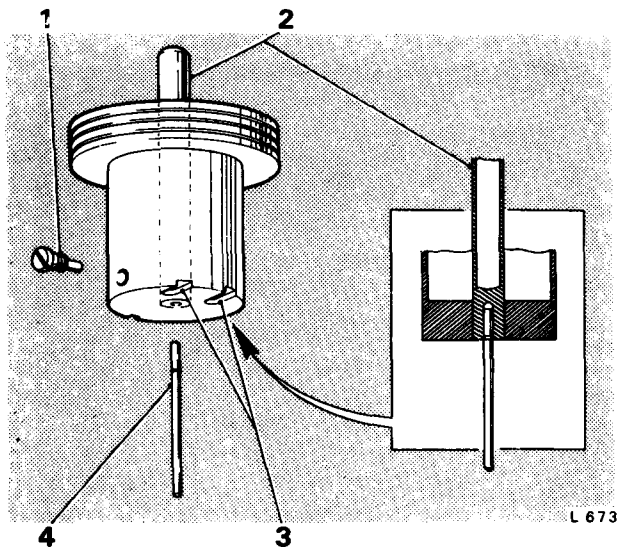

FIG.1 CORRECT POSITION OF THE FIXED NEEDLE

- 1 Needle locking screw
- 2 Piston rod
- 3 Transfer holes
- 4 Needle

3. Check that the piston key is secure in the carburetter body.
4. Fit the piston assembly to the body, then fit the piston spring over the piston rod. Fit the suction chamber taking care not to 'wind up' the piston spring. Fit and tighten the suction chamber retaining screws.
5. Ensure the upper portion of the piston rod in each carburetter is filled with the same type of oil as used in the engine. The correct level is approximately 13 mm. (0.50 in.) from the top of the tube.
6. Fit the piston damper and washer.

Carburetters fitted with a spring loaded needle

1. Fit the spring of the spring loaded needle onto the needle collar ensuring that the spring locates in the groove (see Fig. 2).
2. Fit the guide onto the needle so that the end with the indentation is towards the flange on the collar.

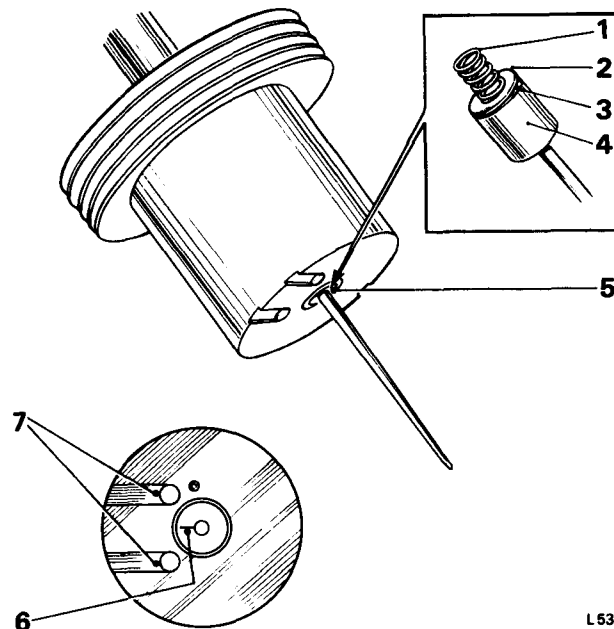

FIG.2 CORRECT POSITION OF THE SPRING LOADED NEEDLE

- 1 Spring
- 2 Collar
- 3 Indentation
- 4 Guide
- 5 Needle and guide position
- 6 Guide mark
- 7 Transfer holes and cut-outs

3. Fit the needle and guide into the piston. The lower face of the guide must be flush with the face of the piston (*see Fig. 2*), and the mark on the guide must be adjacent to the point midway between the two cut-outs in the piston.

4. Fit and tighten the guide locking screw to the piston.

5. Check that the piston key is secure in the carburetter body.

6. Fit the piston assembly to the carburetter body, carefully guiding the needle into the jet.

7. Fit the piston spring over the piston rod.

8. Fit the suction chamber, taking care not to 'wind up' the piston spring. Fit and tighten the suction chamber retaining screws.

9. Ensure the upper portion of the piston rod in each carburetter is filled with the same type of oil as used in the engine. The correct level is

approximately 13 mm. (0.50 in.) from the top of the tube.

10. Fit the piston damper and washer.

Tuning the carburetters

For the tuning and setting of the idle CO, reference should be made to the relevant 'model year' of Chapter U.

Carburetter tamperproofing (if fitted)

If during the tuning of the carburetter it is necessary to adjust the idle CO setting, then retamperproofing of the carburetter adjusters will be necessary.