



Workshop Manual

**Rolls-Royce Silver Shadow
(including Long Wheelbase Saloon)
Rolls-Royce Corniche
Bentley T Series
and Bentley Corniche**

Up to and including car serial number 30000

Wiring Diagrams

CONTENTS

		SECTION
Theoretical	R.H.D. cars prior to Serial Number 5000	1
Practical	R.H.D. cars prior to Serial Number 5000	2
Theoretical	R.H.D. cars from Serial Number 5000 to 6000	3
Theoretical	L.H.D. cars from Serial Number 6000 to 9000	4
Practical	L.H.D. cars from Serial Number 6000 to 9000	5
Theoretical	L.H.D. Long Wheelbase cars with Division from Serial Number LRX 6598	6
Practical	L.H.D. Long Wheelbase cars with Division from Serial Number LRX 6598	6
Practical	L.H.D. cars prior to Serial Number 6000	7
Practical	R.H.D. Long Wheelbase cars with Division from Serial Number LRX 6598	8

CONTENTS cont.

R 539

SECTION

Printed in England

September 1972

T.S.D. 2476

Practical	R.H.D. cars from Serial Number 9000	9
Practical	L.H.D. cars from Serial Number 9000	10
Practical	L.H.D. Long Wheelbase cars with Division from Serial Number 9000	11
Practical	R.H.D. and L.H.D. cars Radio Receivers and Stereo Tape Equipment from Serial Number 9000	12
Practical	L.H.D. cars from Serial Number 11882	13
Theoretical	All cars built to 1972 Electrical Specification	14
Theoretical	All cars built to 1973 Electrical Specification	15
Theoretical and practical	Rolls-Royce Silver Shadow and Bentley 'T' series saloons built to August 1975 Electrical Specification	16
Theoretical	Rolls-Royce & Bentley Corniche with Automatic Air Conditioning	17

KEY TO DIAGRAMS

It should be noted that the colours indicated in the table are often combined in pairs e.g. 14GY-C. The number '14' represents the cable size, the cable comprising of 14 strands of wire, each strand being 0.010 in. diameter. The 'GY' indicates that the cable is two colour, Green and Yellow and the 'C' indicates that the cable is cotton covered.

CABLE COLOUR CODE

B = Black S = Slate
 G = Green U = Blue
 N = Brown W = White
 P = Purple Y = Yellow
 R = Red

CABLE SIZES

14 = 14/.010in.
 28 = 28/.012in.
 44 = 44/.012in.
 65 = 65/.012in.
 120 = 120/.012in.

CABLE TYPE

'C' denotes cotton covered cable
 'P' denotes plastic covered cable

EXAMPLE

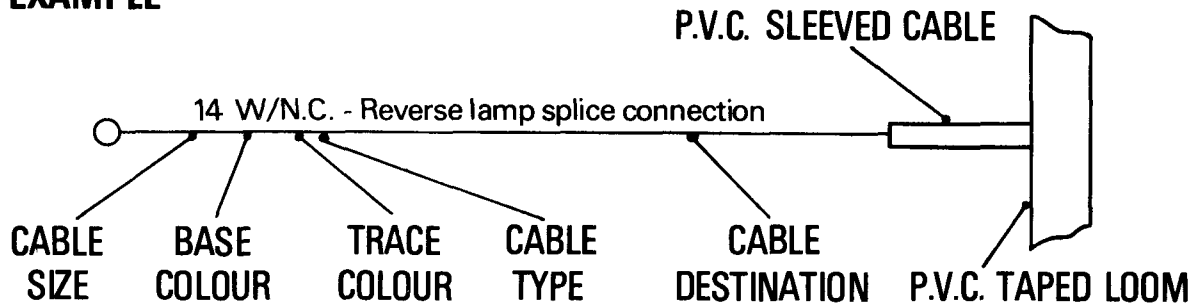

CONNECTION DETAILS

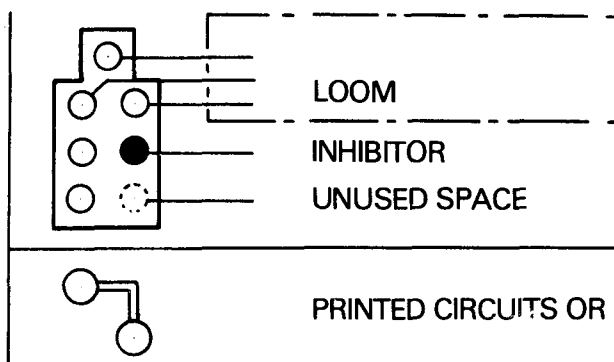
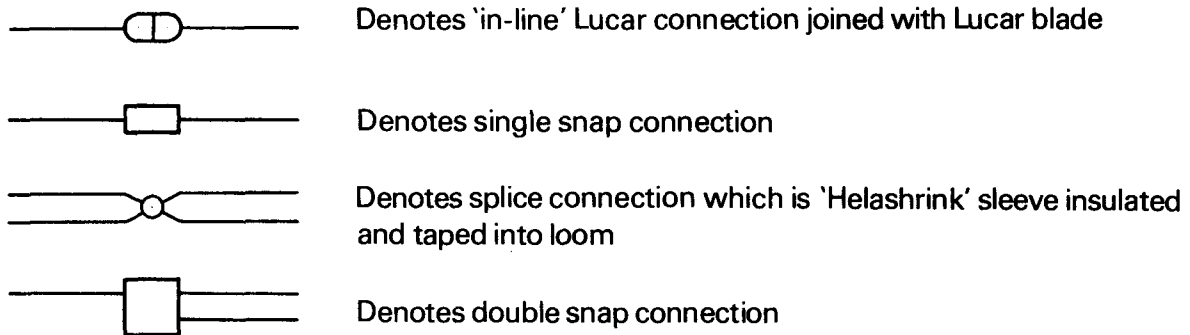

Section 1

RIGHT-HAND DRIVE CARS PRIOR TO SERIAL NUMBER 5000

APPLICATION	SHEET No
Theoretical	1
Theoretical	2

THEORETICAL WIRING DIAGRAM

SHEET 1

ROLLS-ROYCE SILVER SHADOW AND BENTLEY T SERIES 4-DOOR SALOONS

TSD Publication 2218

© Rolls-Royce Limited (1966)

Rolls-Royce policy is one of continuous engineering improvement and the right is reserved to revise the contents of this publication without prior notice.

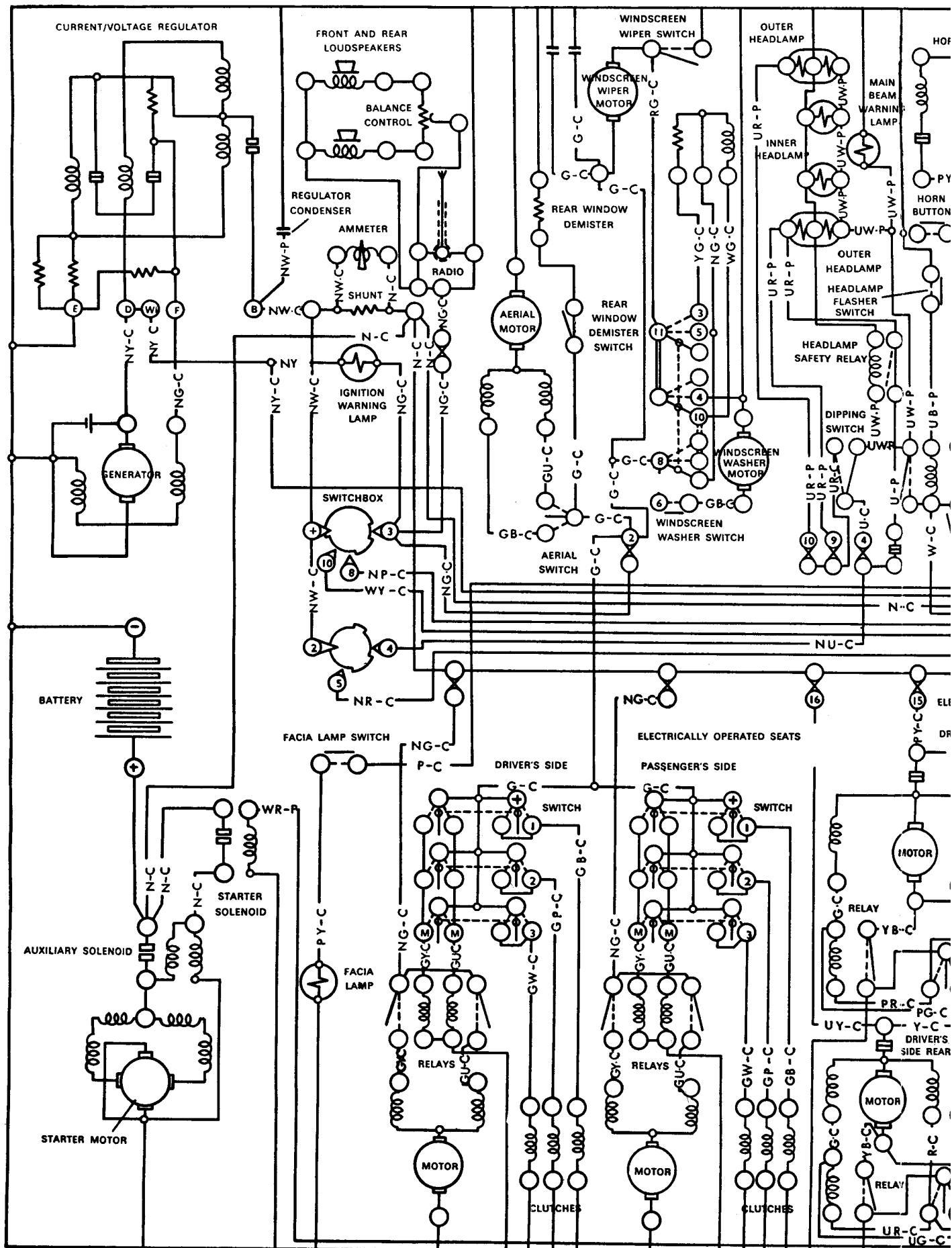

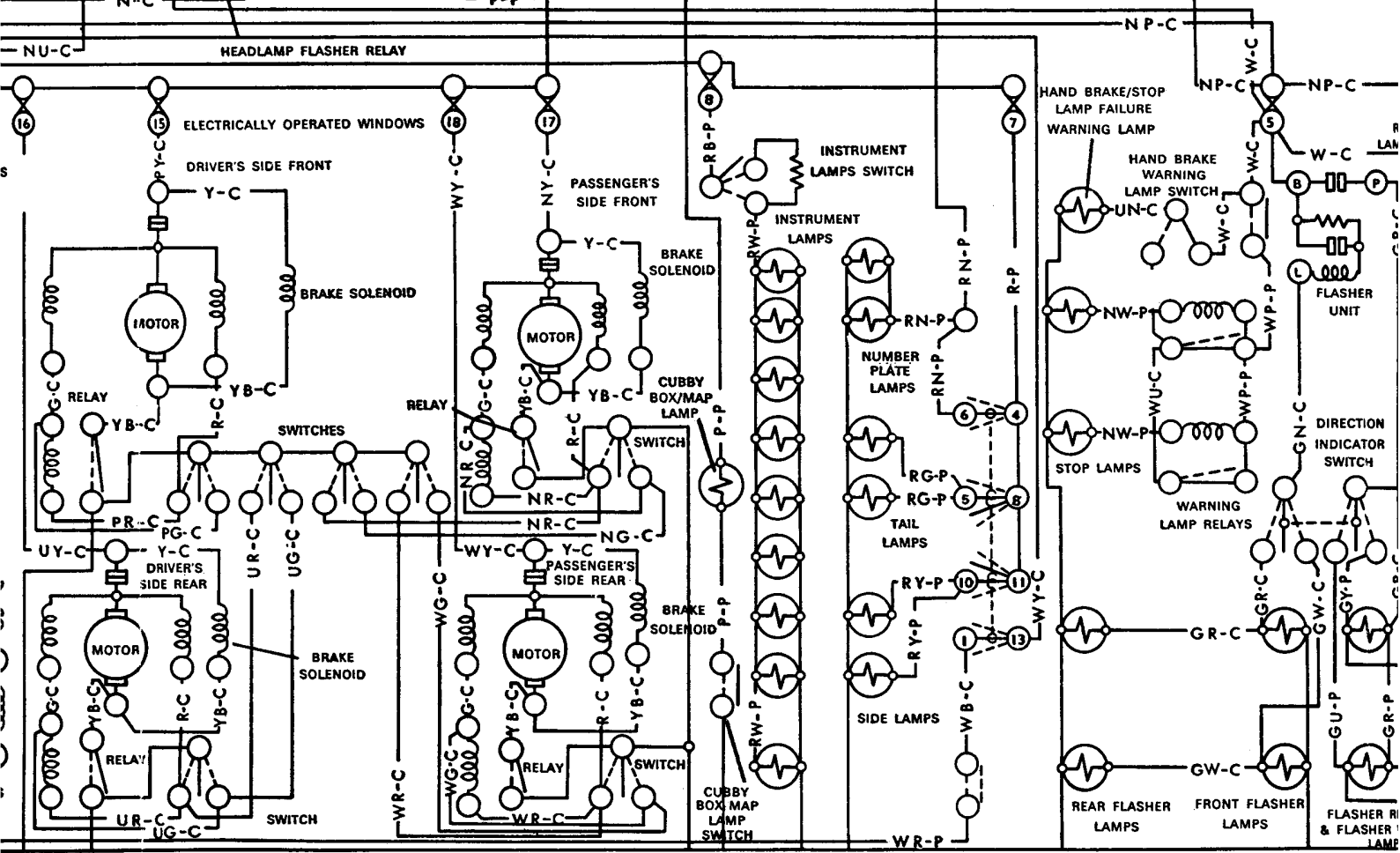
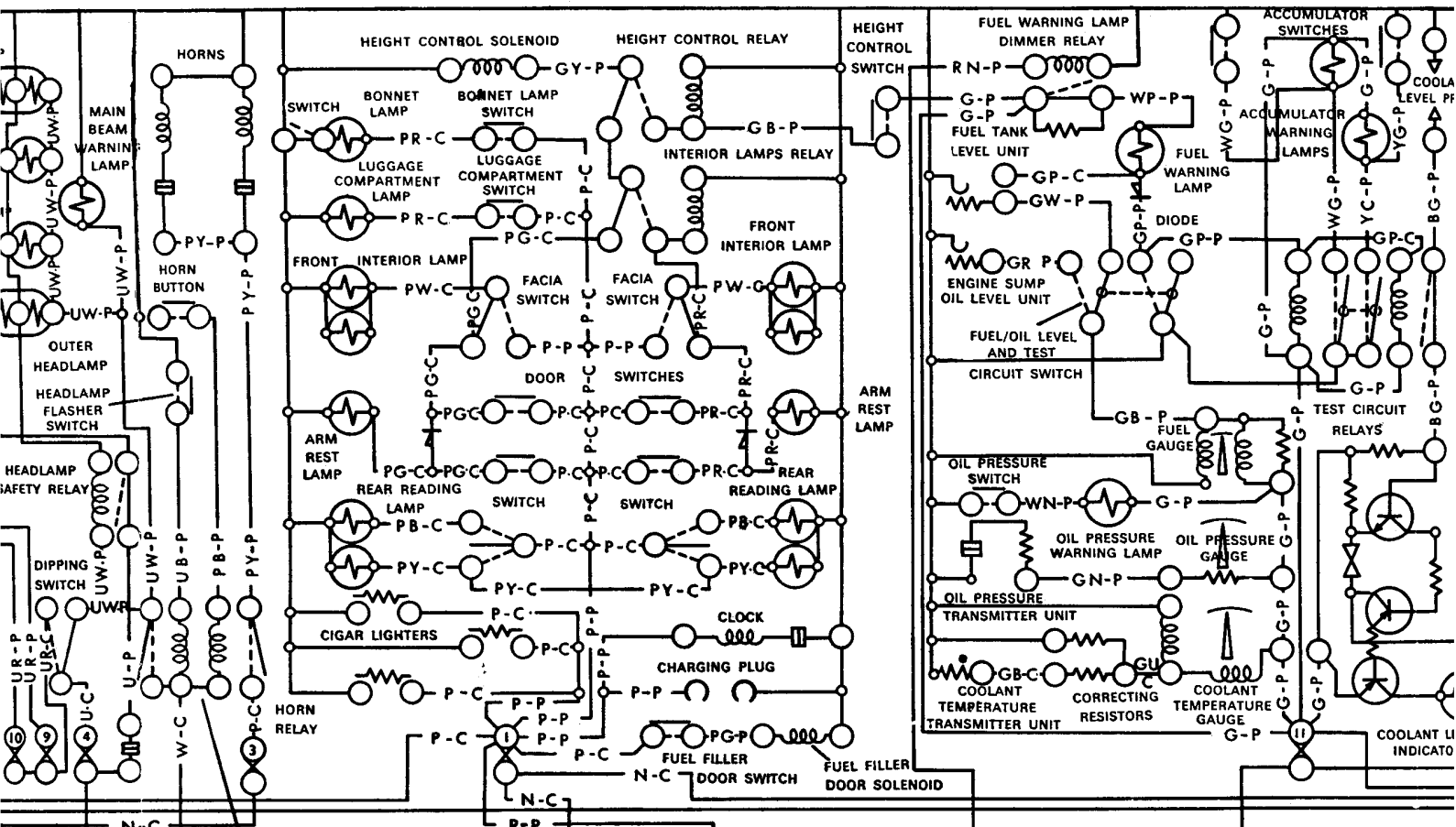

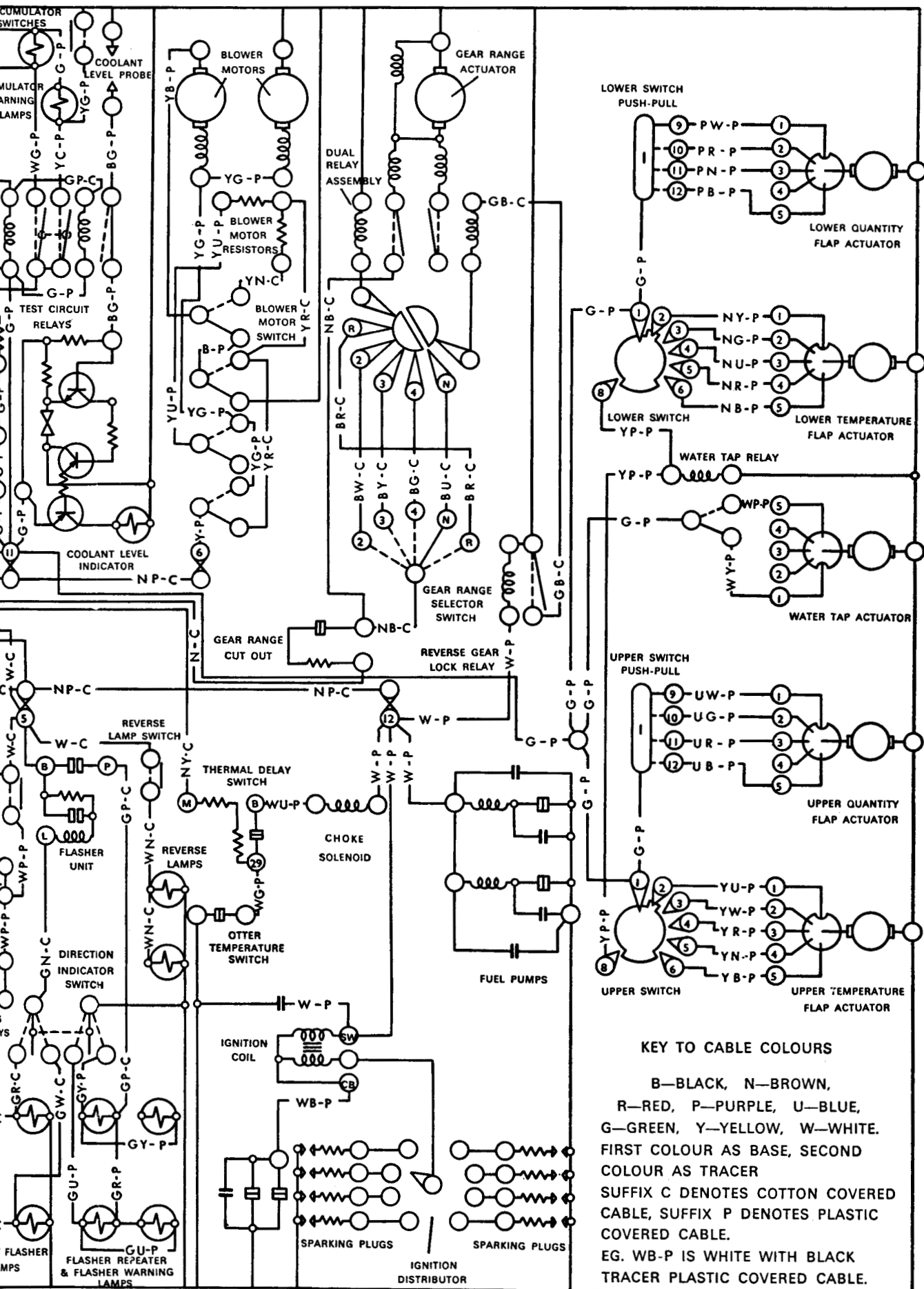

THEORETICAL WIRING DIAGRAM
SHEET 2

ADDITIONAL AND ALTERNATIVE CIRCUITS
TO SHEET 1

ROLLS-ROYCE SILVER SHADOW
AND
BENTLEY T SERIES
4-DOOR SALOONS

TSD Publication 2218

© Rolls-Royce Limited (1967)

**Rolls-Royce policy is one of continuous engineering
improvement and the right is reserved to revise the
contents of this publication without prior notice.**

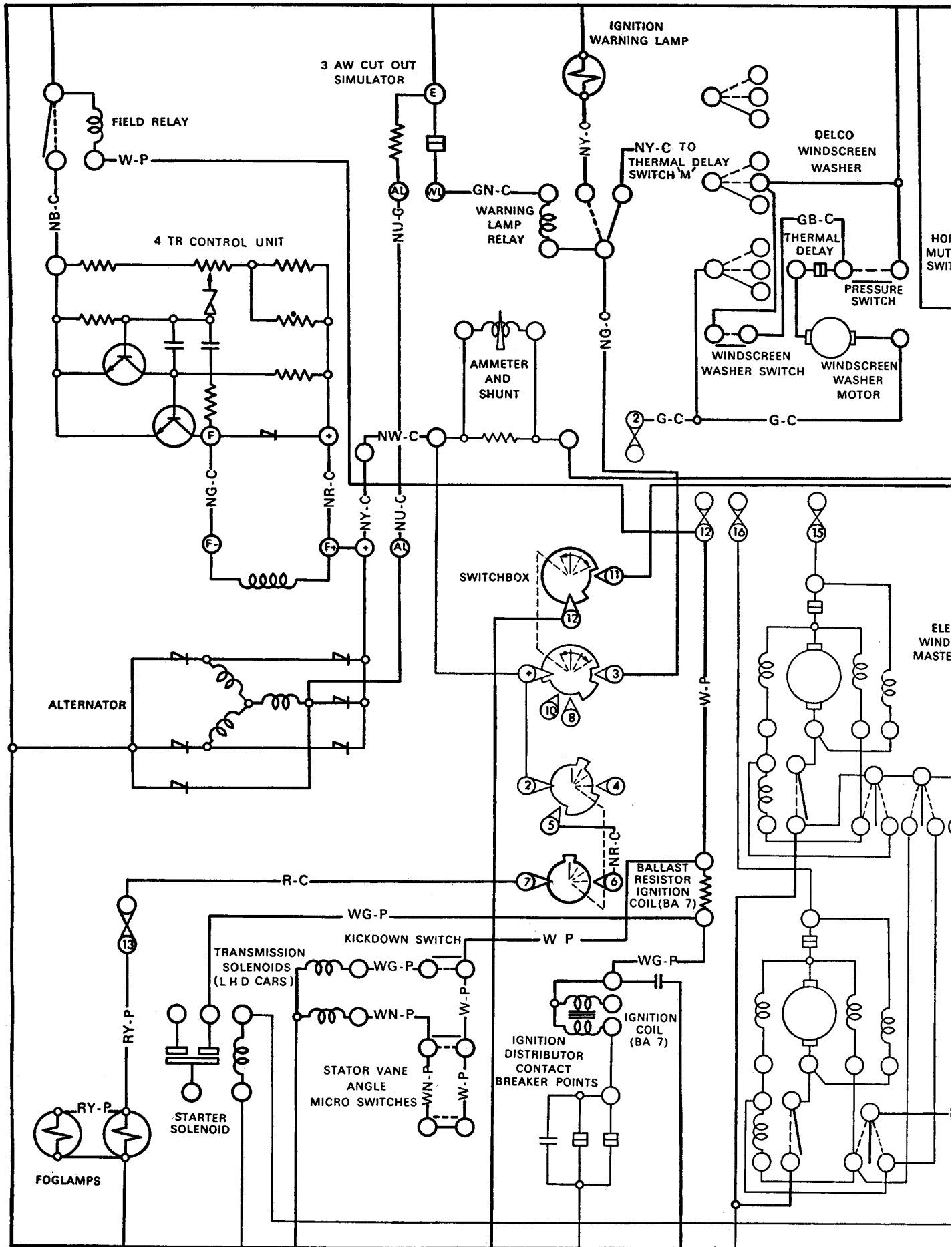

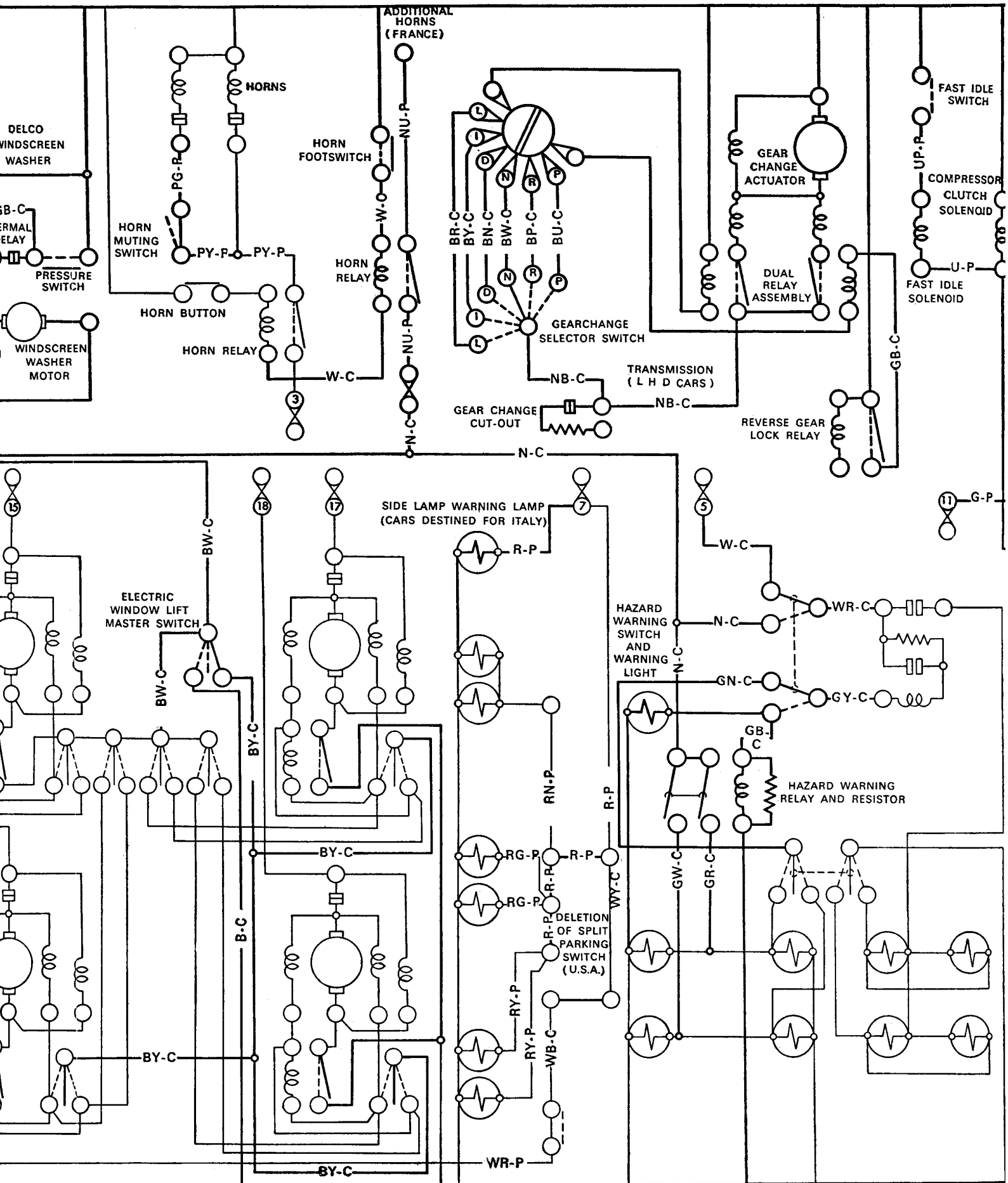

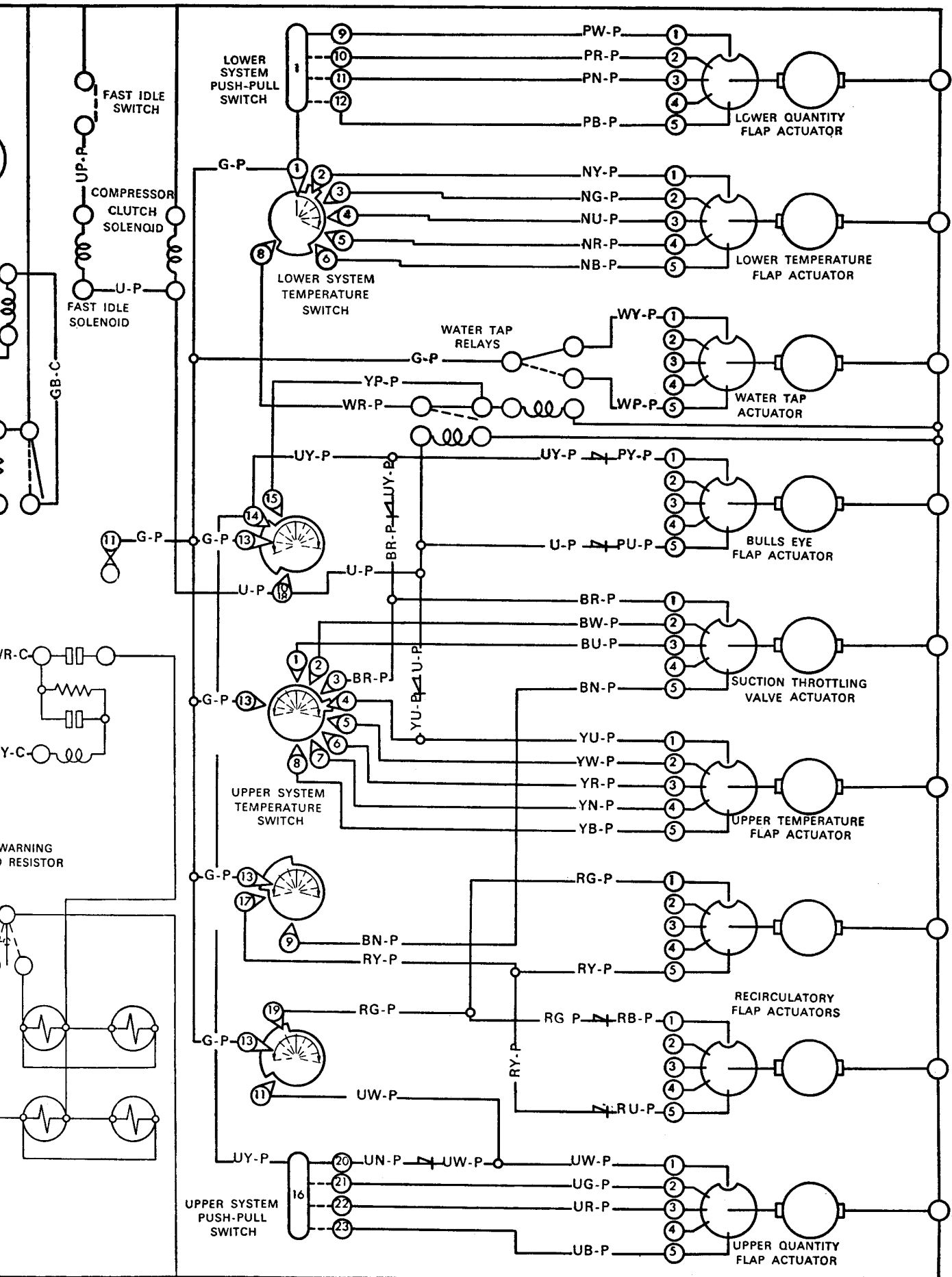

Section 2

RIGHT-HAND DRIVE CARS PRIOR TO SERIAL NUMBER 5000

APPLICATION	SHEET No
Charging, Starter and Distribution	1
Engine and Instruments	2
Lighting	3
Direction Indicators and Handbrake Warning Lamp	4
Electrically Operated Windows	5
Electrically Operated Seats	6
Gear Range Selector	7
Air Conditioning Unit (A.C.U.)	8
Radio Receiver and Speakers	9
Interior Lighting	10

SHEET 1

CHARGING, STARTER AND DISTRIBUTION

R.H. DRIVE CARS

FIRST EDITION

T.S.D. Publication 2432

© *Rolls-Royce Limited, 1967*

28 B-C

R. H. VALANCE EARTH POINT

R. H. VALANCE LO

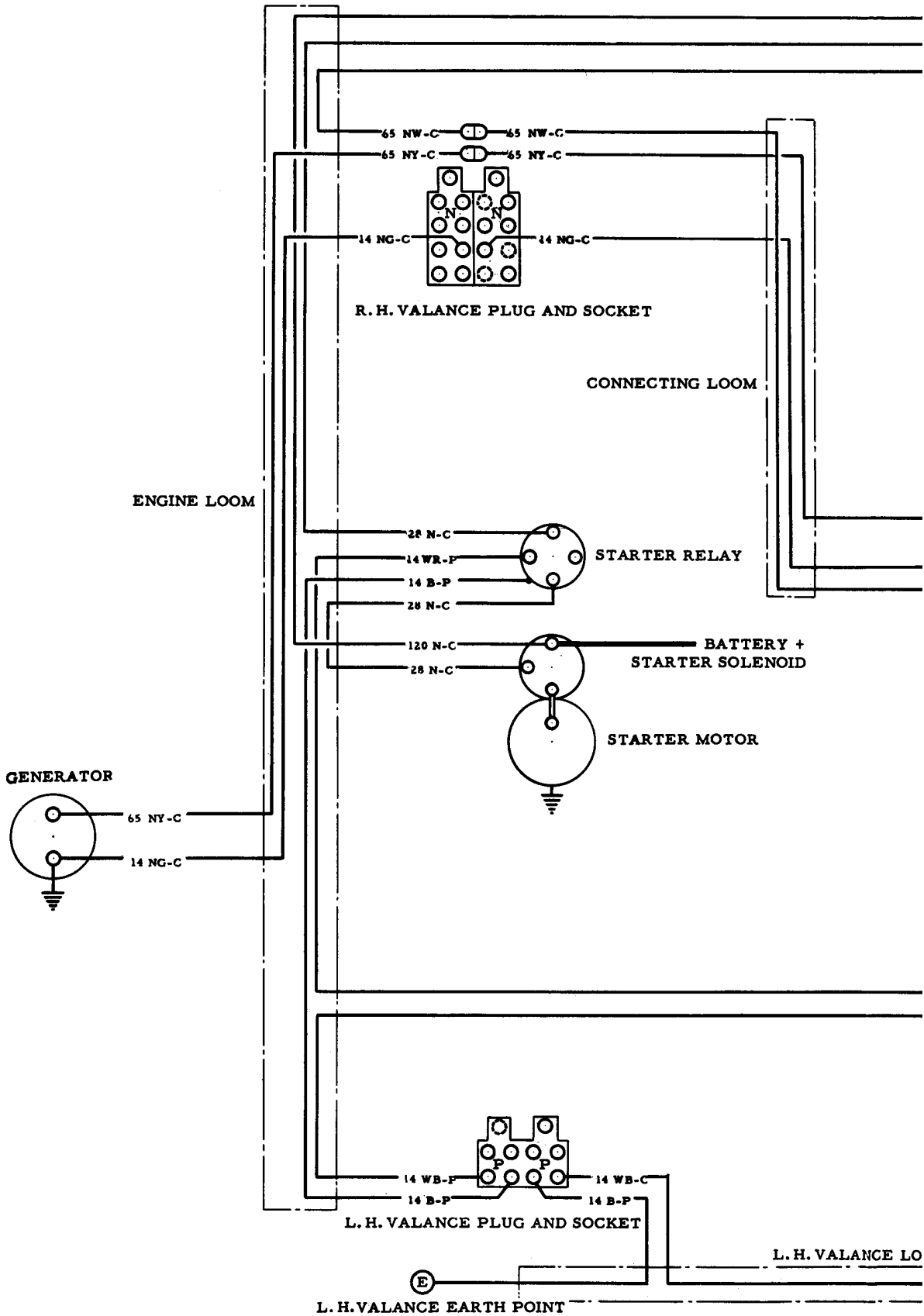

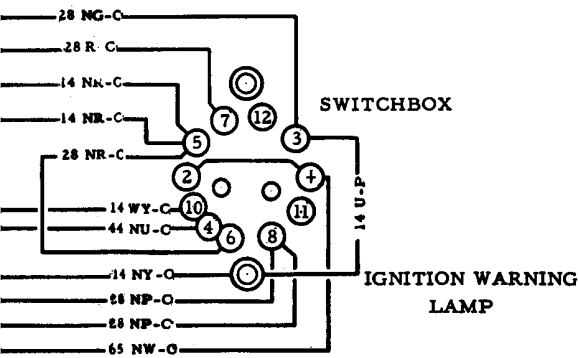
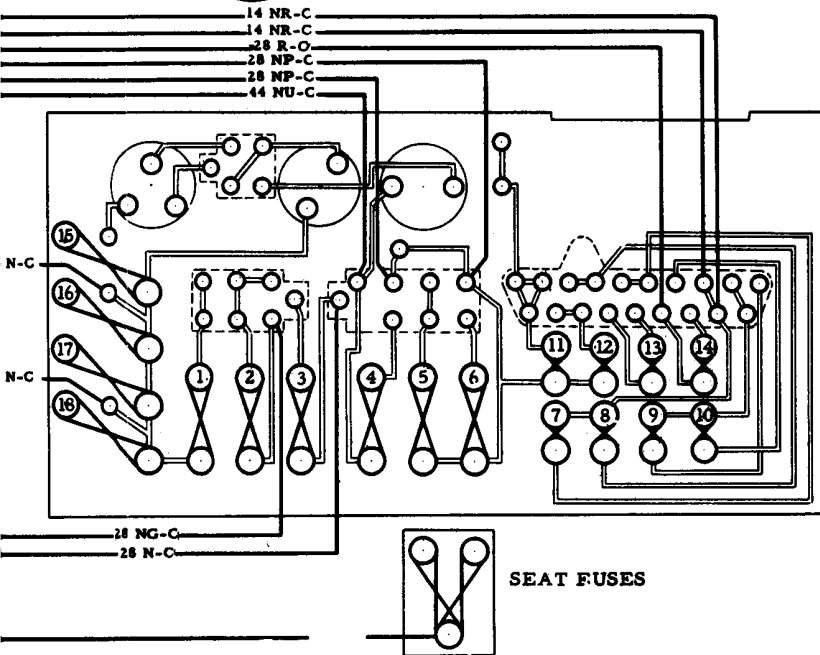

SWITCHBOX FUNCTIONS	
(+) (2)	FEED
(3)	'ON' WITH IGNITION AND 'PICNIC'
(4)	HEADLAMPS
(5)	SIDELAMPS
(6)	FEED FOR FOGLAMPS
(7)	FOGLAMPS
(8)	IGNITION
(10)	STARTER
(11) (12)	'IGNITION' CONTROL-ELECTRIC WINDOW LIFT

SHEET 2

ENGINE AND INSTRUMENTS

R.H. DRIVE CARS

FIRST EDITION

T.S.D. Publication 2432

© *Rolls-Royce Limited, 1967*

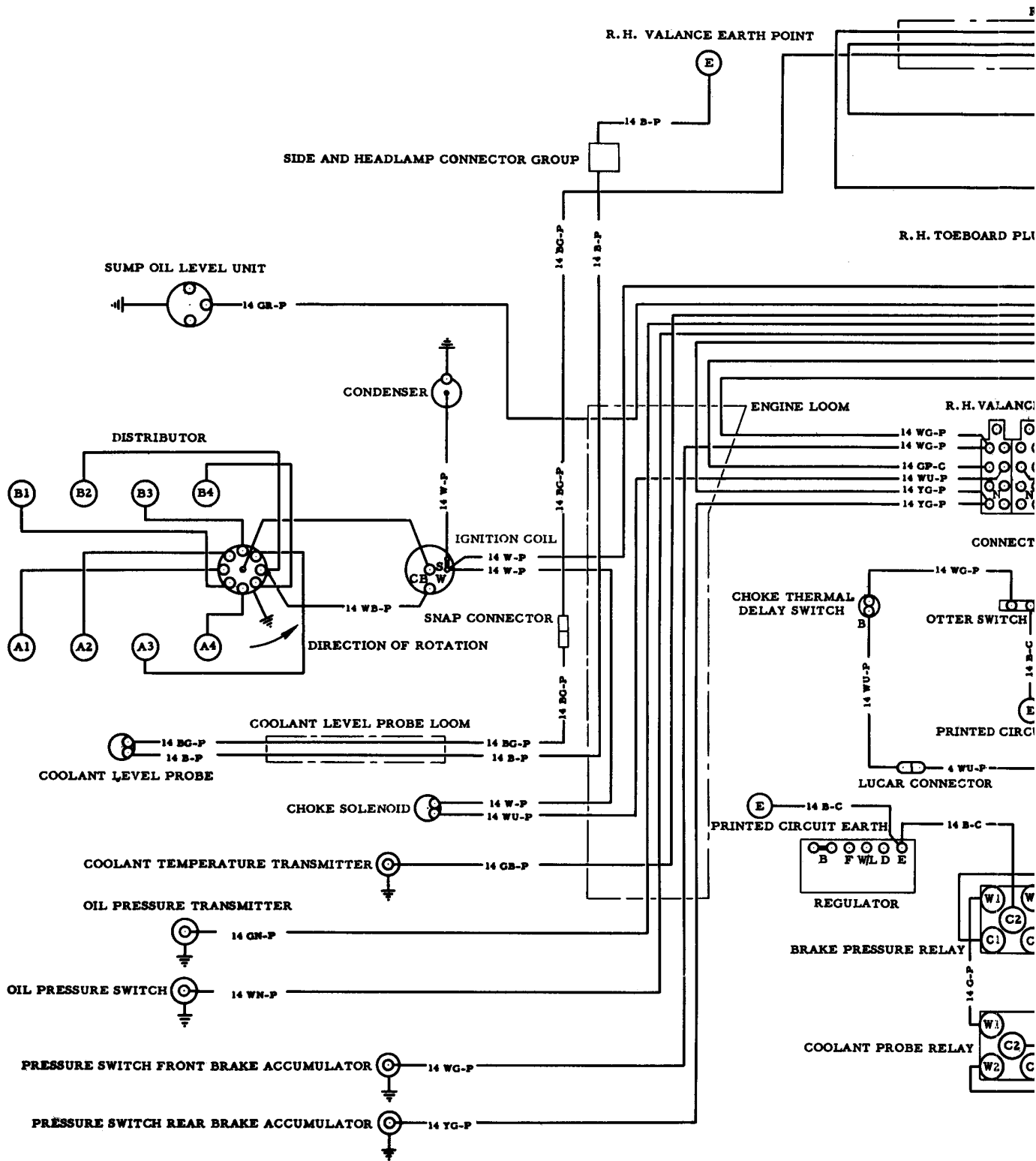

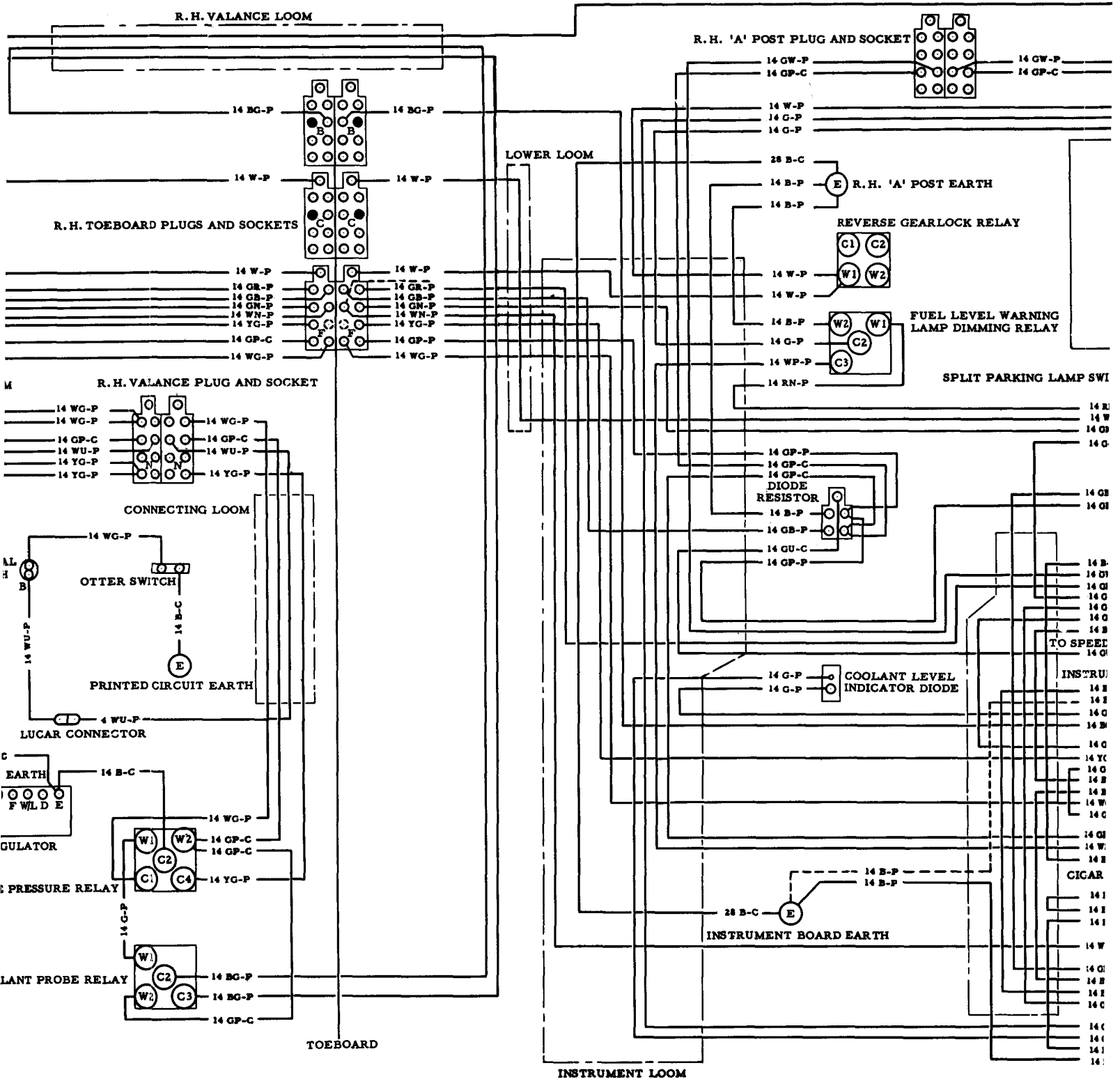

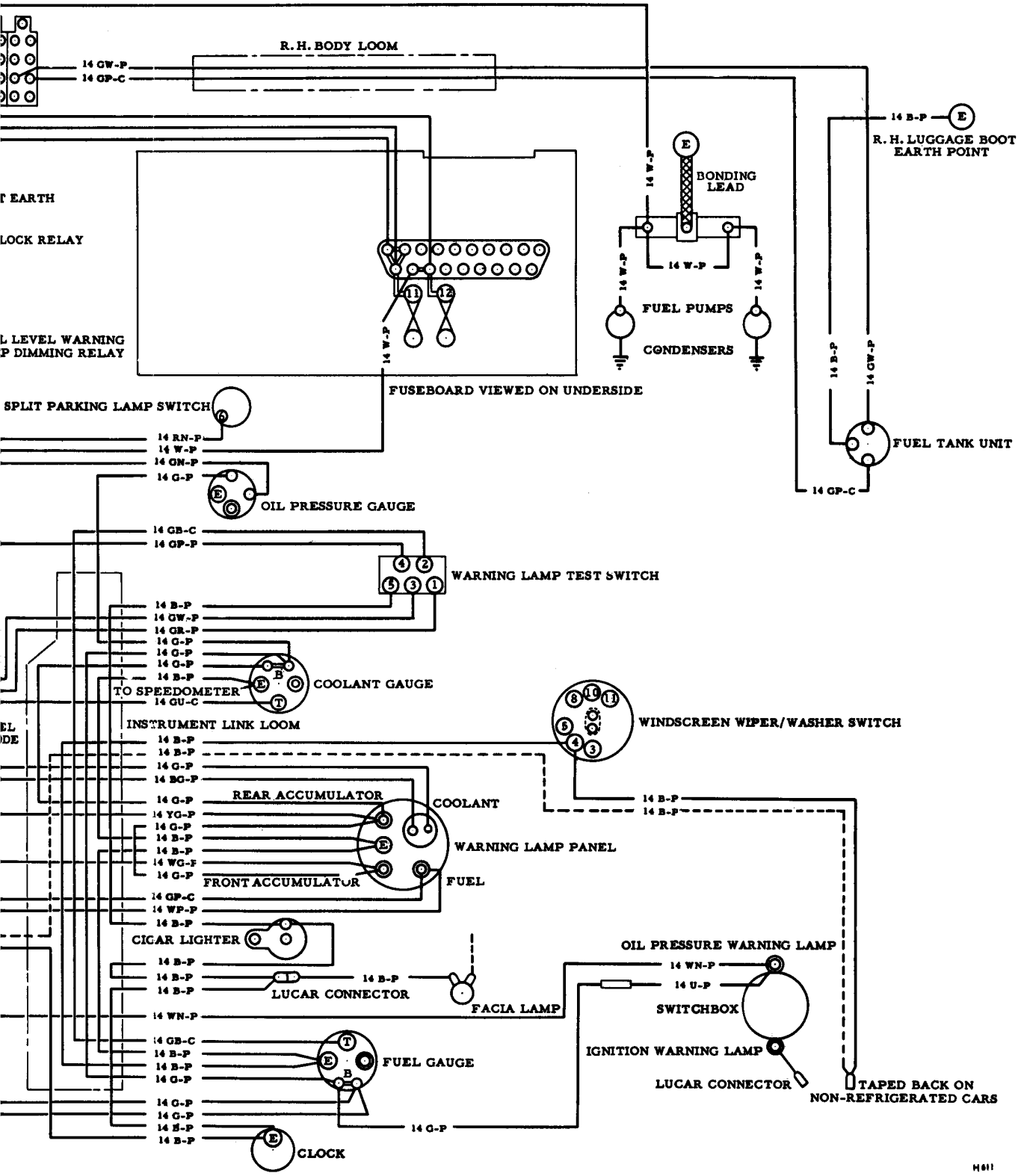

SHEET 3

LIGHTING

R.H. DRIVE CARS

FIRST EDITION

T.S.D. Publication 2432

© *Rolls-Royce Limited, 1967*

R.H. VALANCE EARTH POINT (E)

R.H. 'A' POST EARTH POINT (E)

R.H. VALANCE LOOM

R.H. TOEBOARD PLUGS /

SIDE/FLASHER LAMP



14 R-P
14 B-P

TWIN HEADLAMPS



14 UR-P
14 B-P
14 UW-P



14 UW-P
14 B-P

TWIN HEADLAMPS



14 UW-P
14 B-P



14 UW-P
14 B-P
14 UR-P

SIDE/FLASHER LAMP



14 R-P
14 B-P

SIDE/FLASHER AND HEADLAMP SNAP CONNECTOR GROUP

RELAY BOX VIEWED ON UNDERSIDE

SOCKET T

SOCKET U

SOCKET V

SIDE/FLASHER AND HEADLAMP SNAP CONNECTOR GROUP

L.H. VALANCE LOOM

L.H. TOEBOARD PLUGS AND SO

TOEBOARD

L.H. VALANCE EARTH POINT (E)

Printed in England

October 1967

T.S.D. 2432

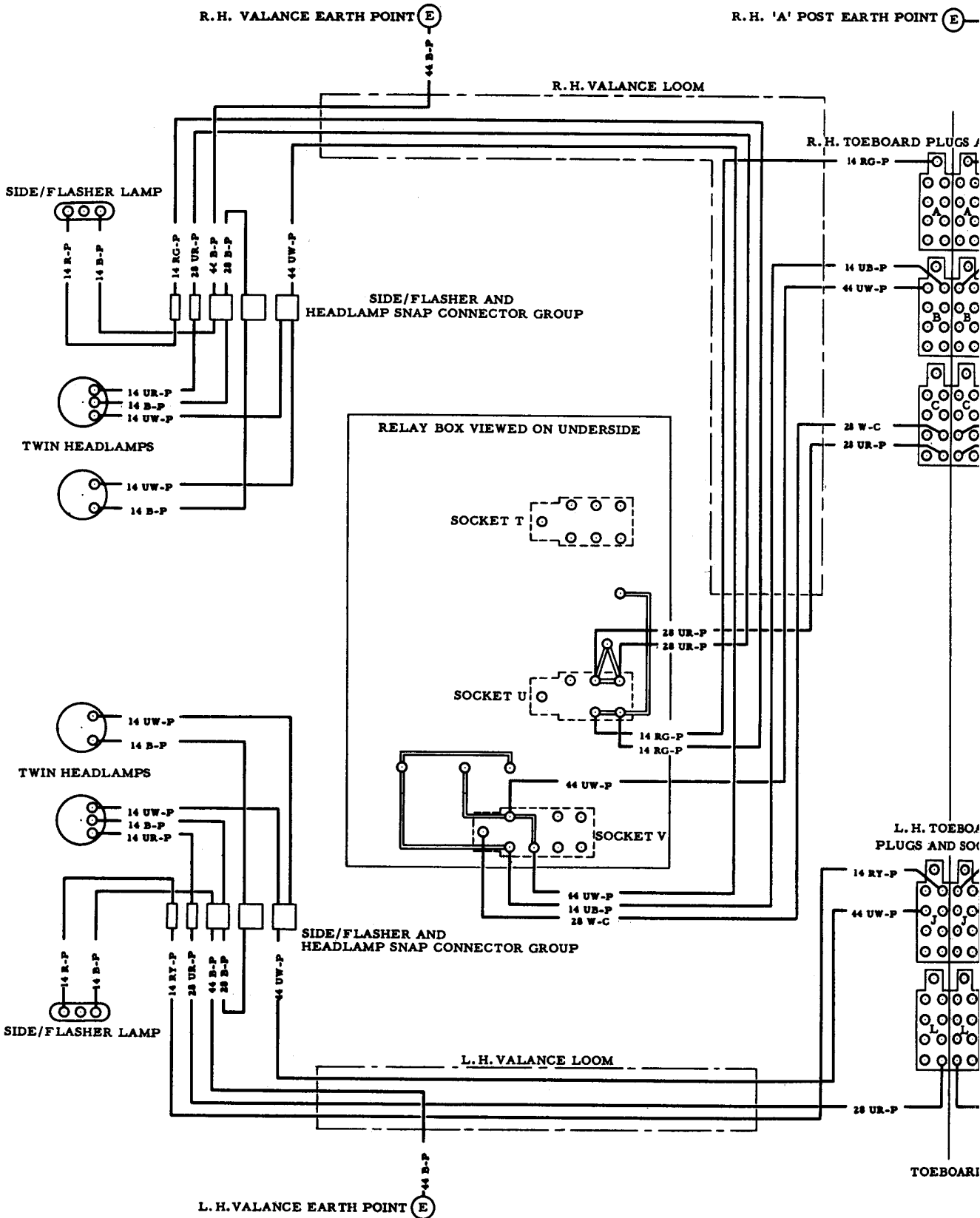

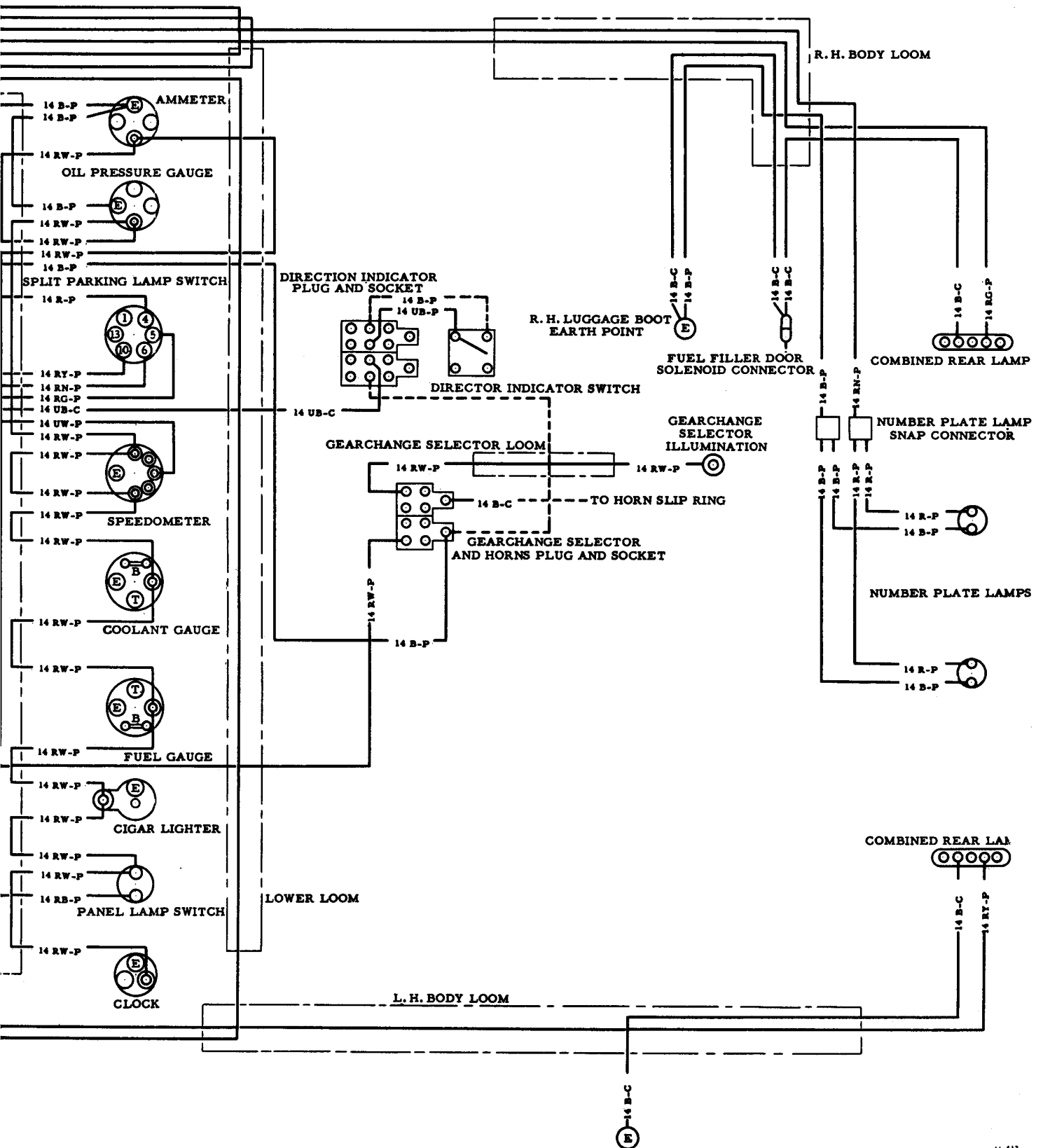

SHEET 4

FLASHERS, WIPERS AND HAND BRAKE WARNING LAMP R.H. DRIVE CARS FIRST EDITION

T.S.D. Publication 2432

© *Rolls-Royce Limited, 1967*

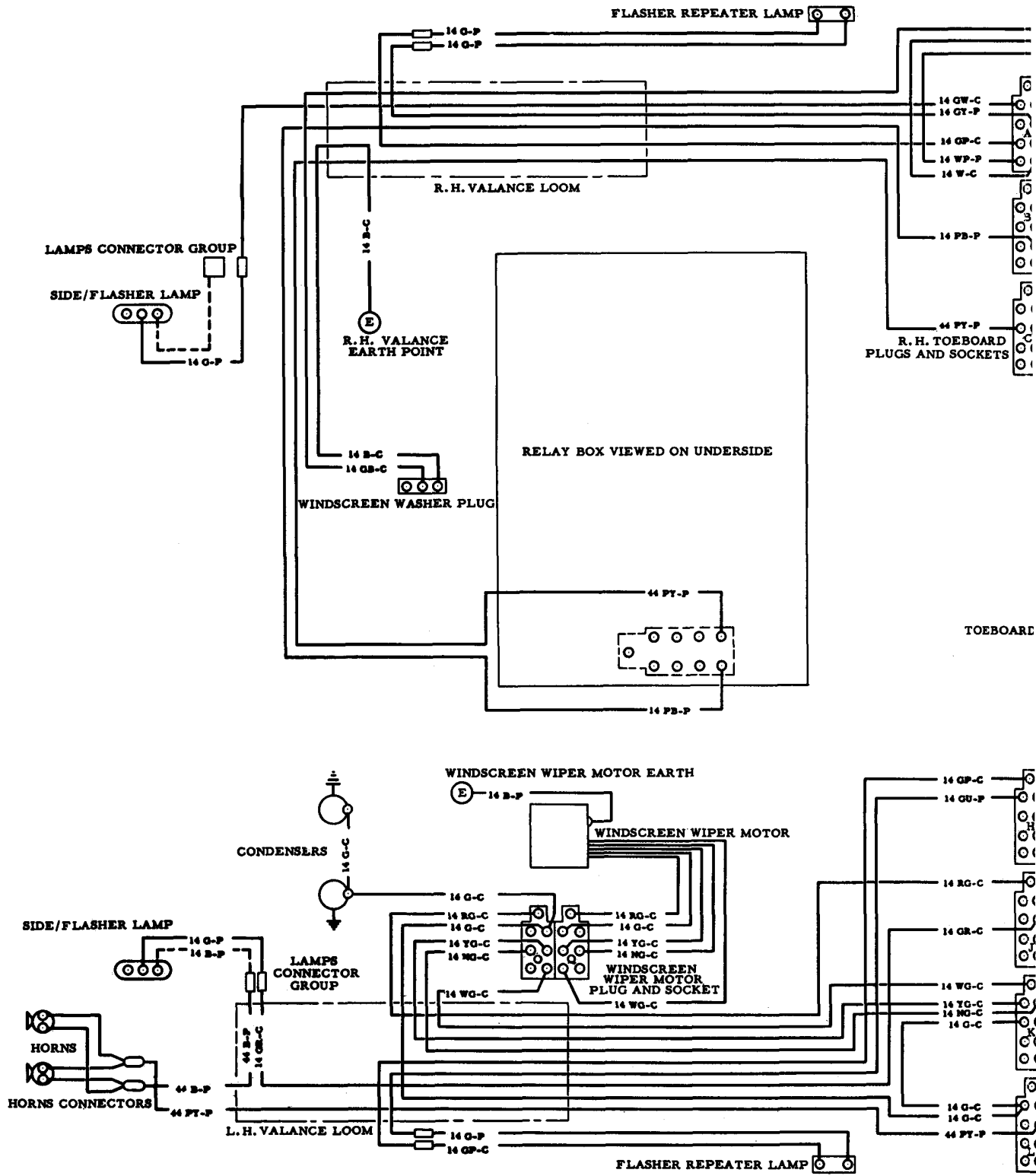

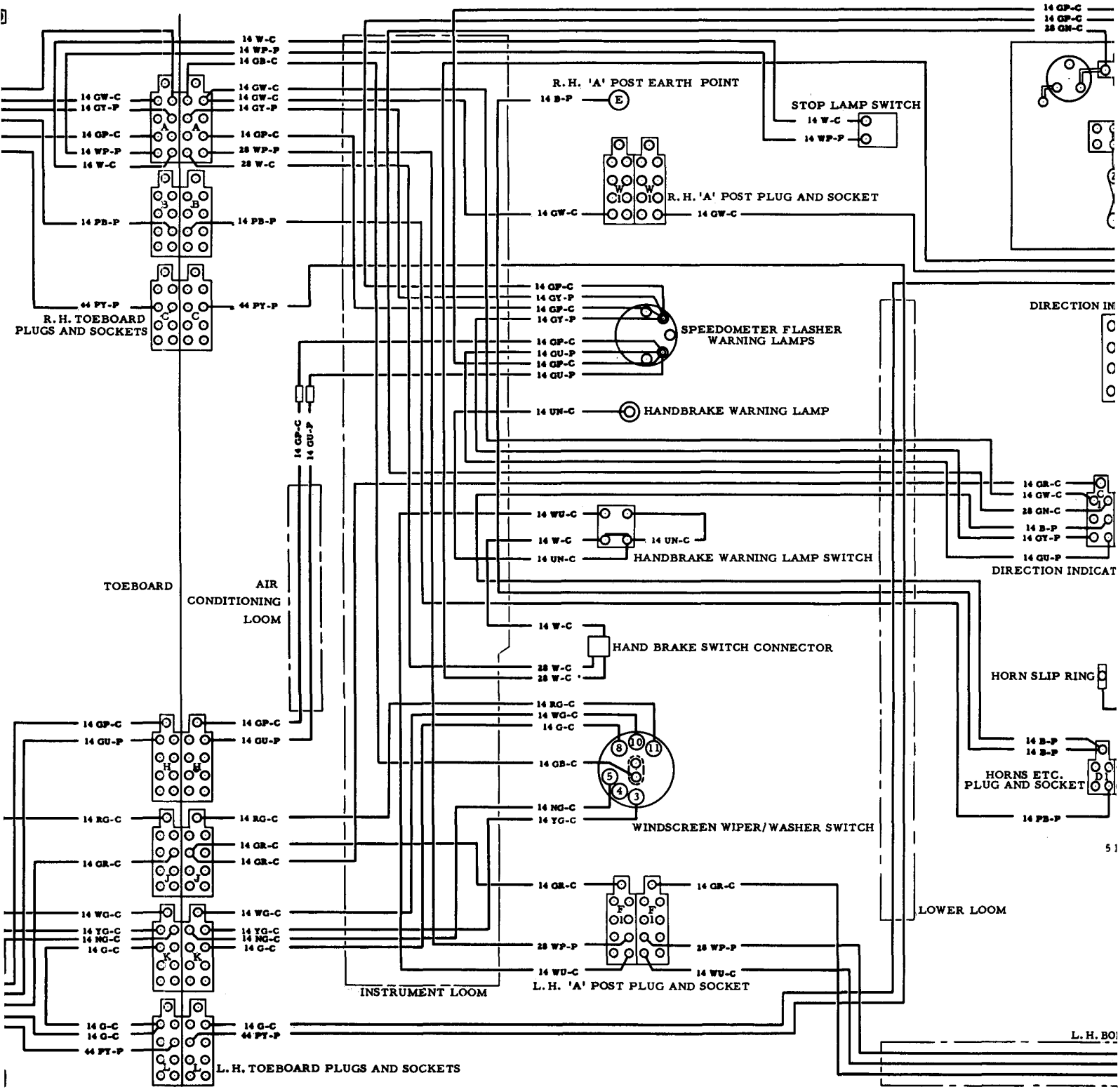

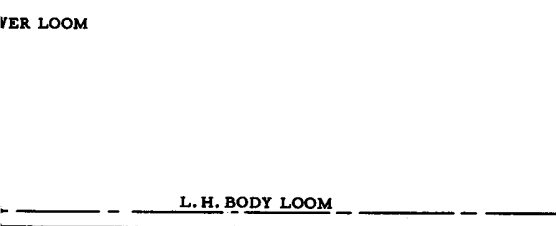
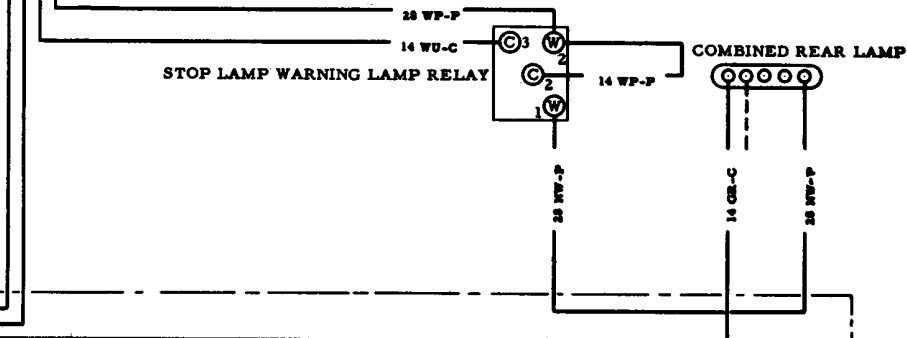
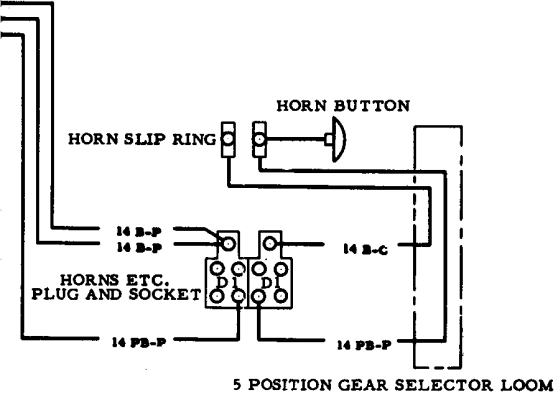
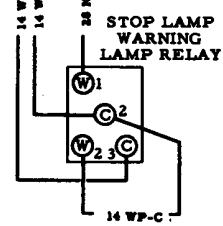
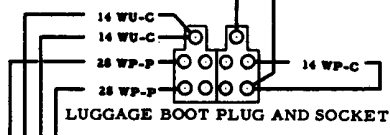
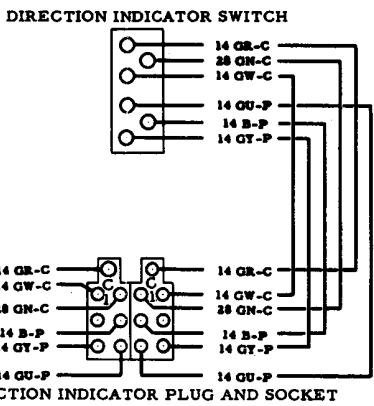
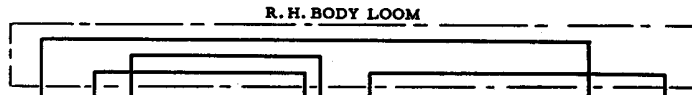
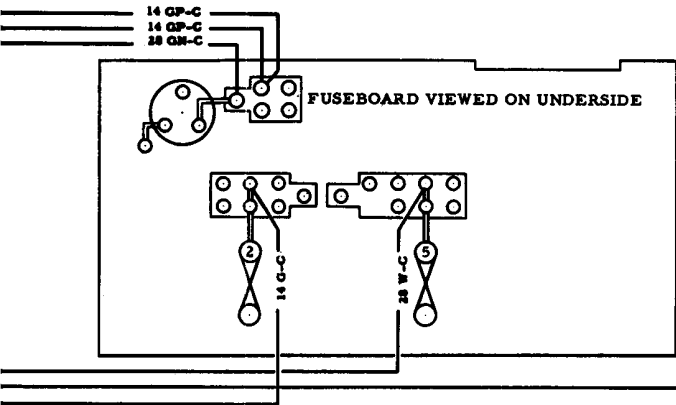

SHEET 5

WINDOW LIFT

R.H. DRIVE CARS

FIRST EDITION

T.S.D Publication 2432

© *Rolls-Royce Limited, 1967*

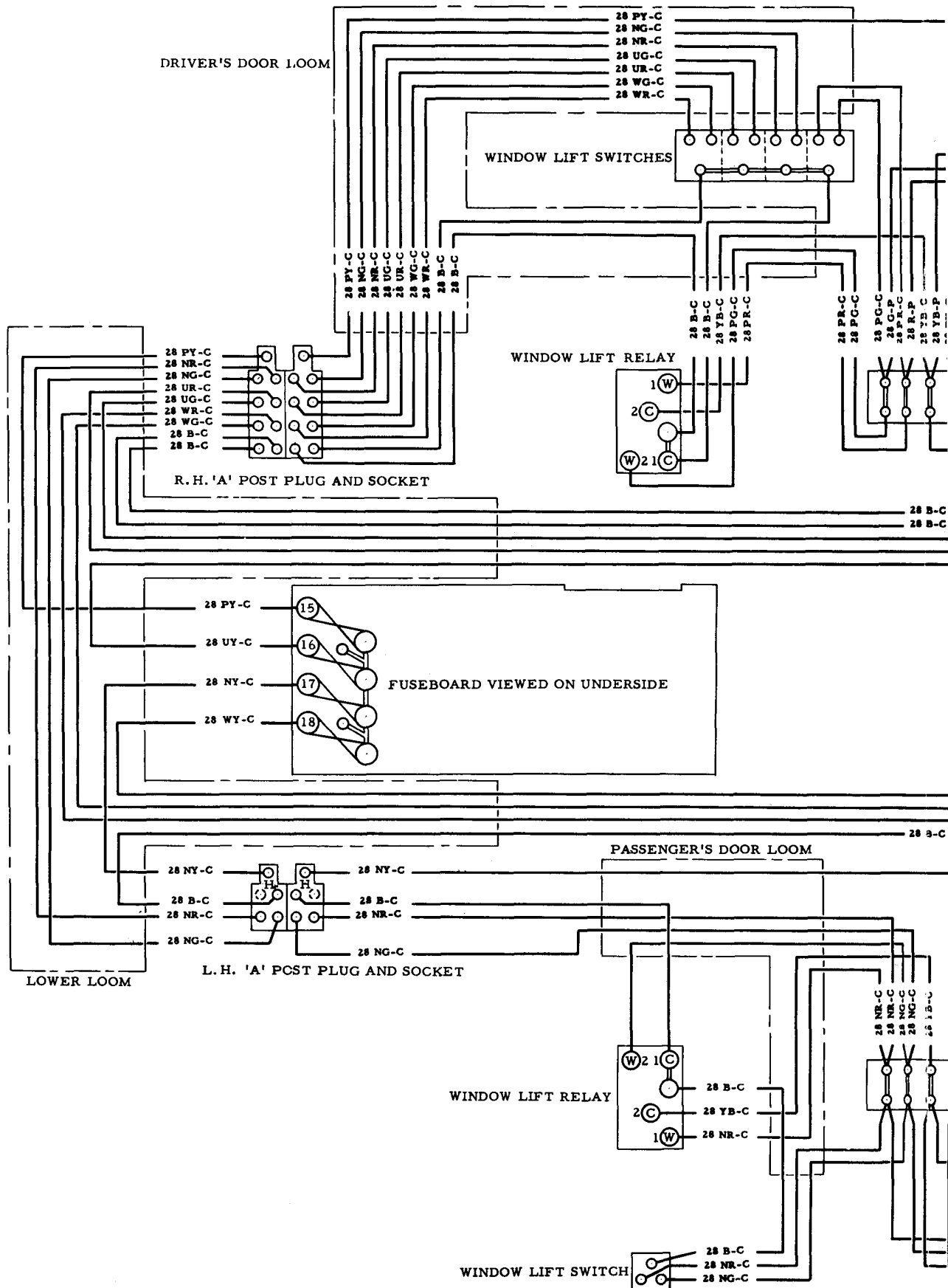

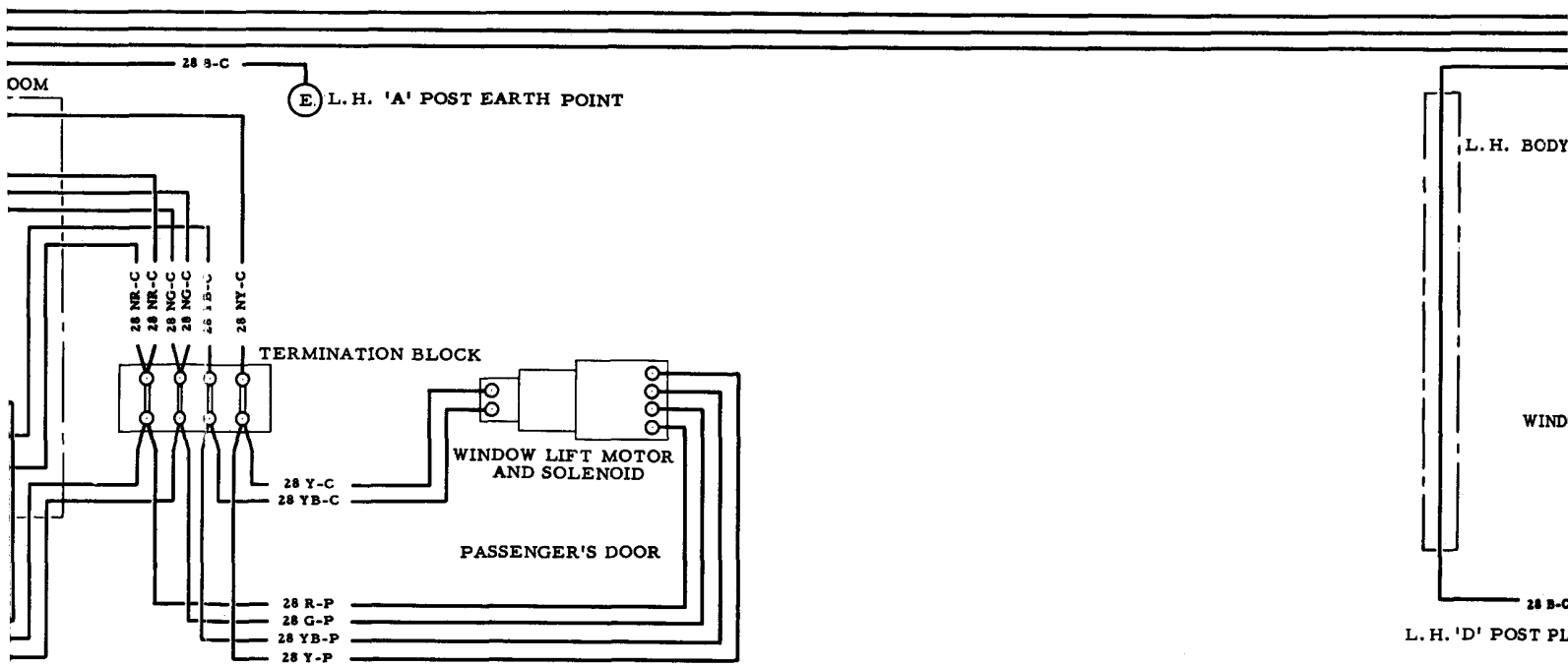
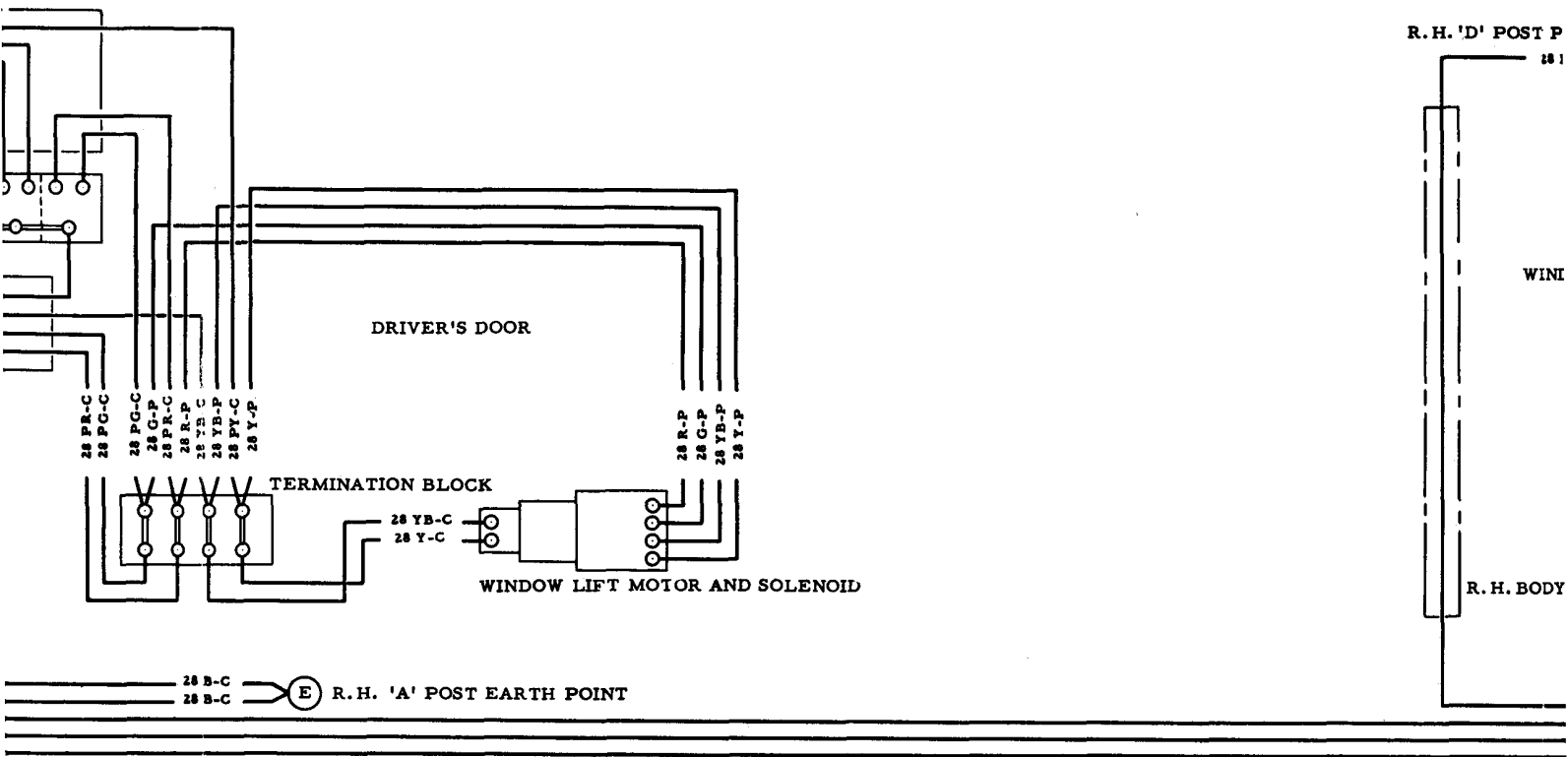

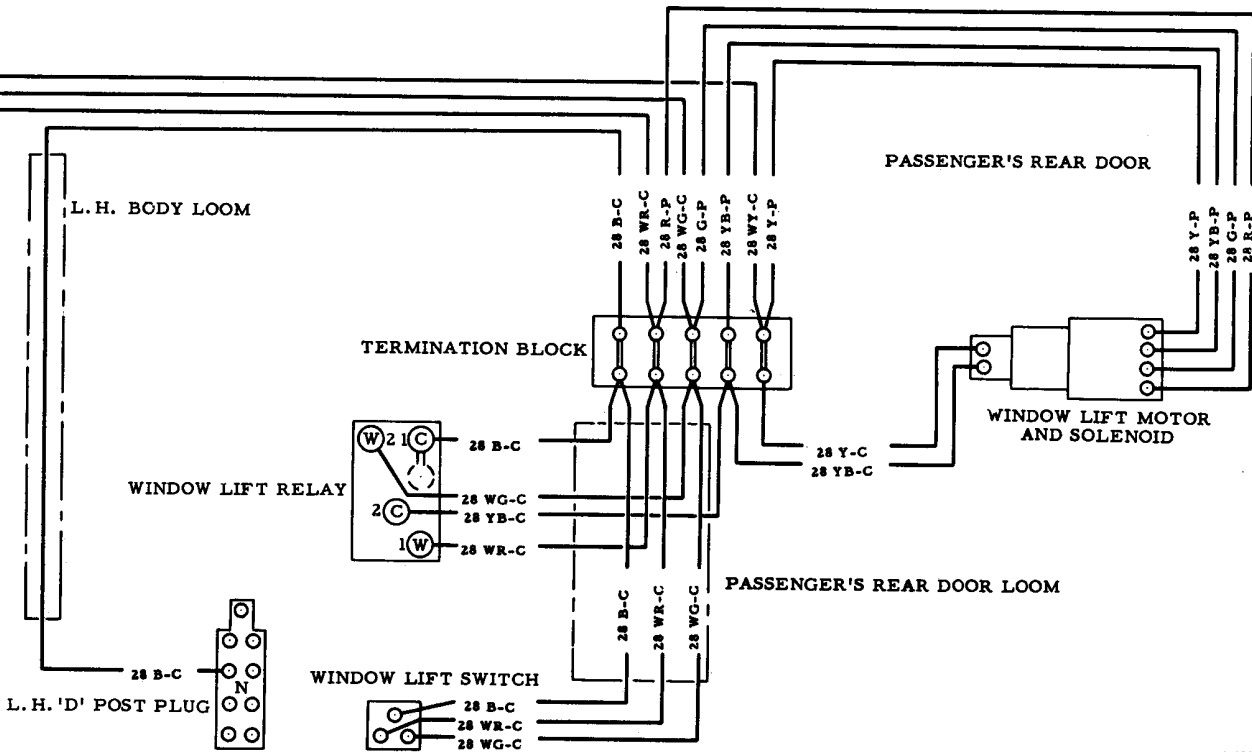
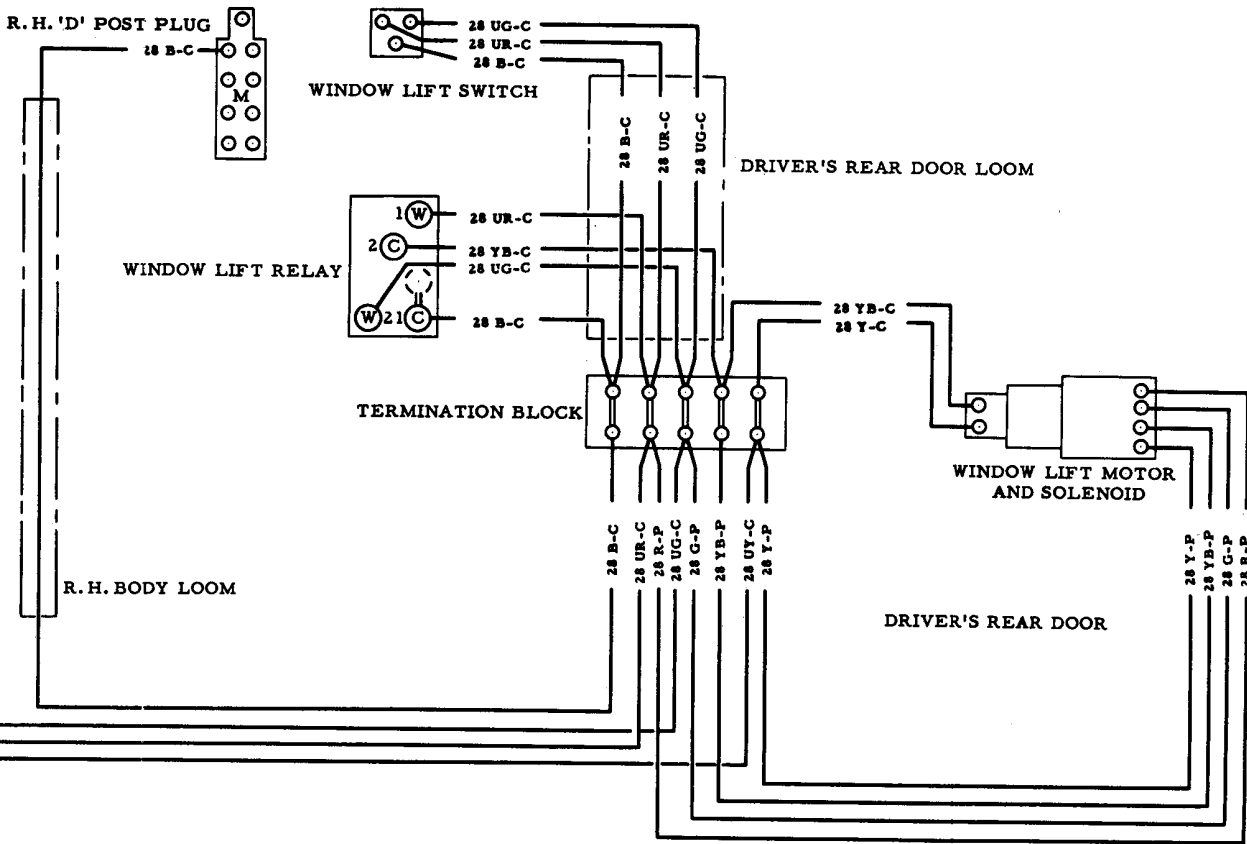

SHEET 6

ELECTRICALLY OPERATED SEATS

R.H. DRIVE CARS

FIRST EDITION

T.S.D. Publication 2432

© *Rolls-Royce Limited, 1967*

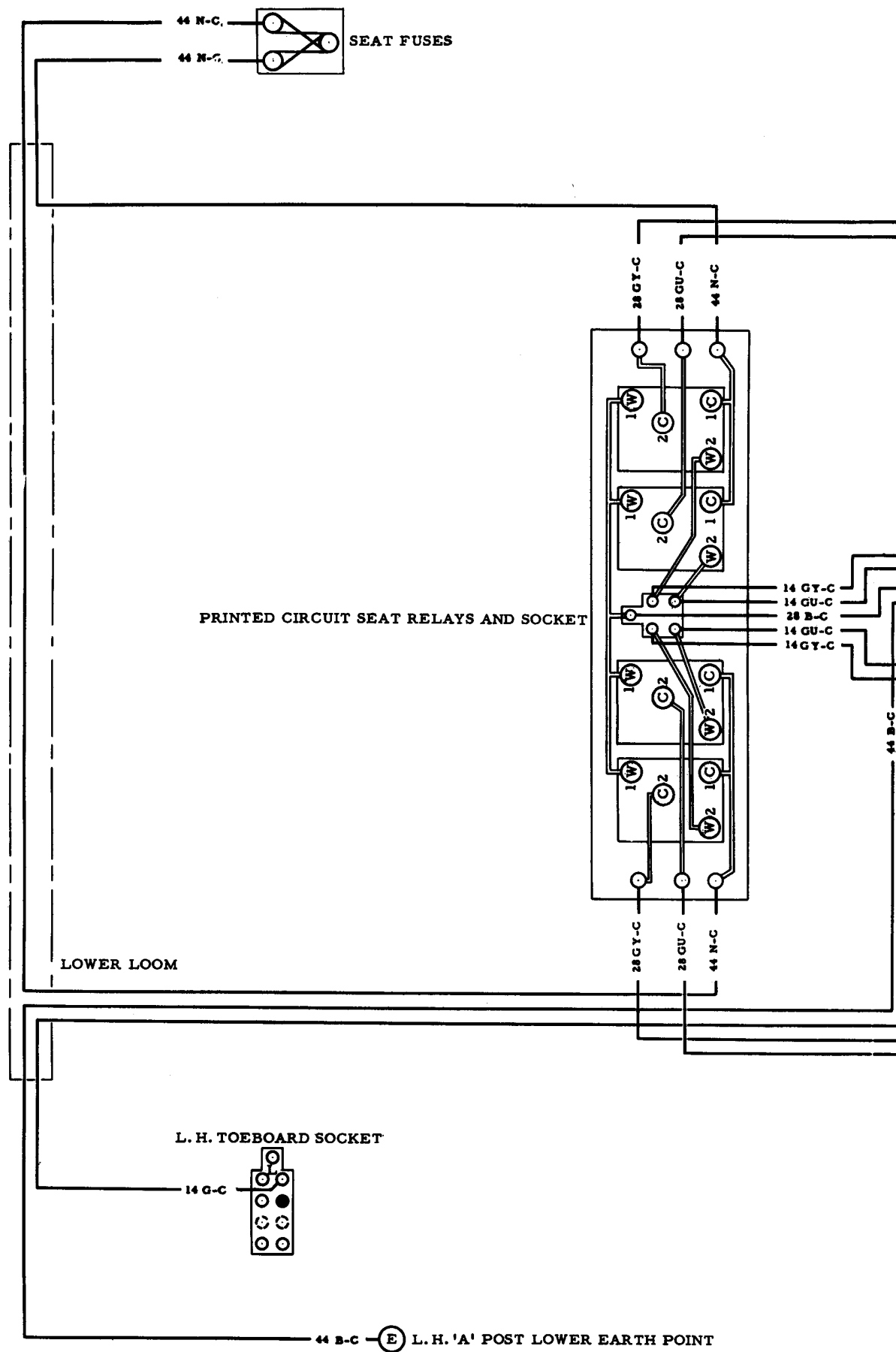

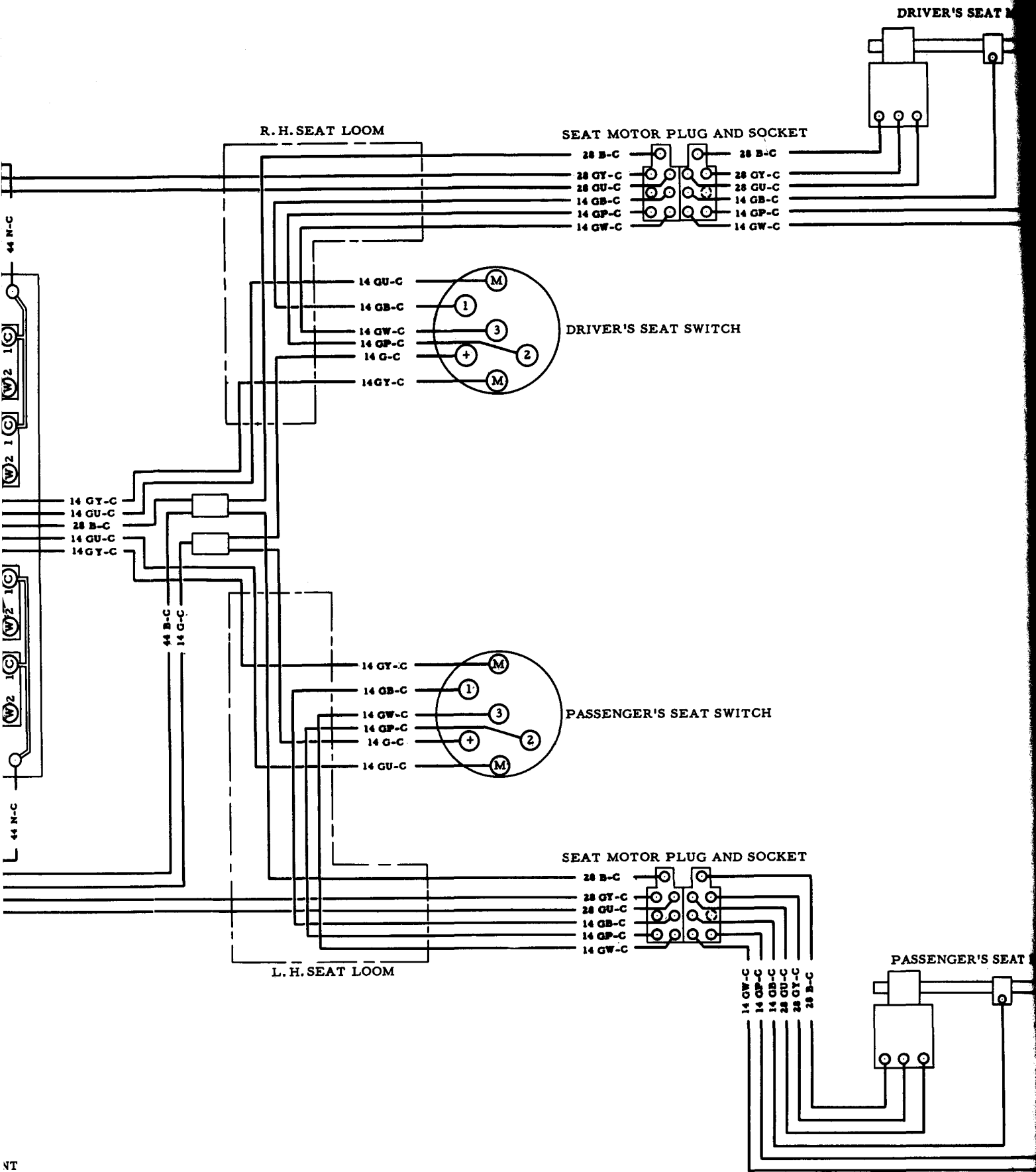

NT

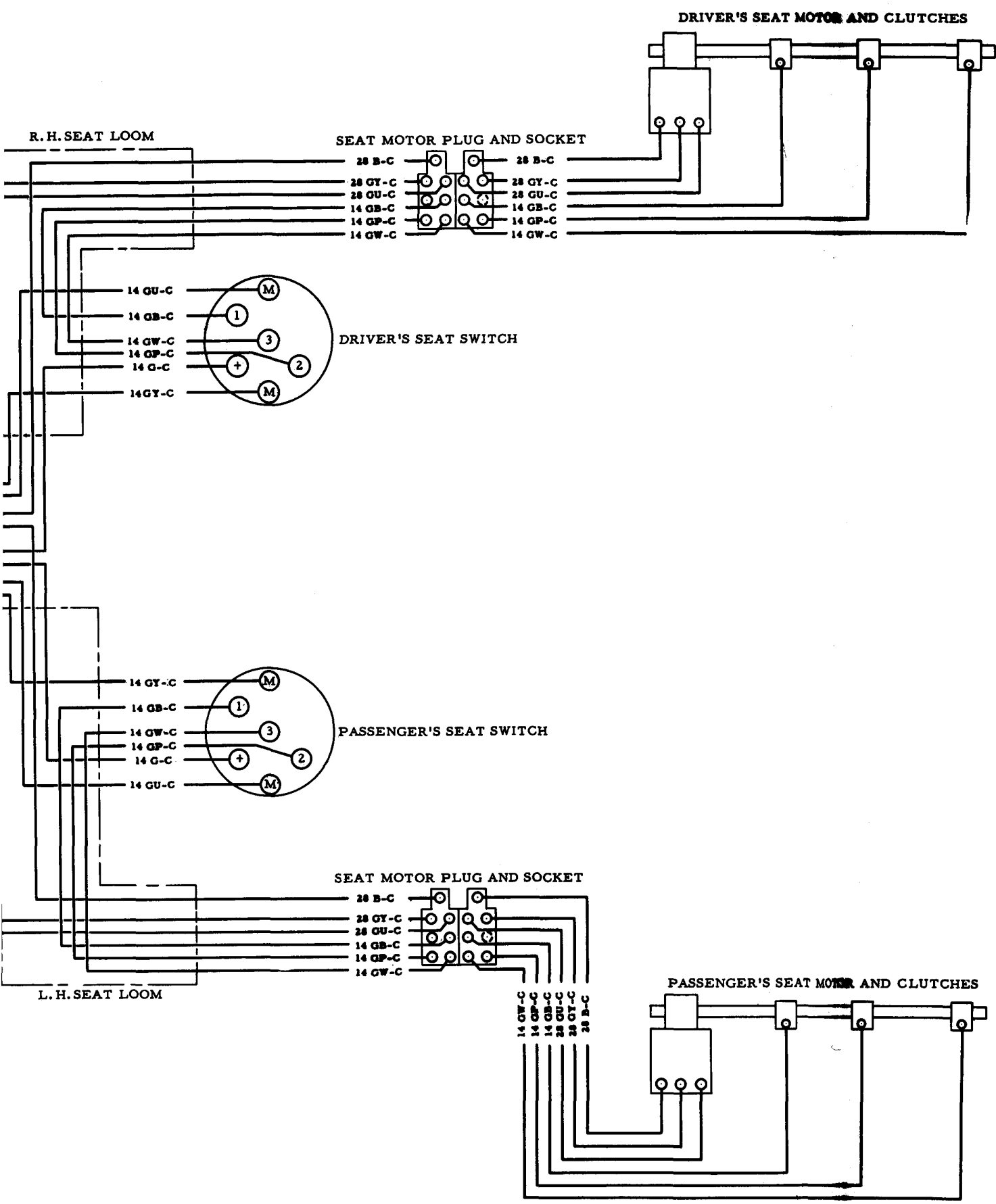

PRACTICAL WIRING DIAGRAM

SHEET 7

GEAR RANGE SELECTOR

ROLLS-ROYCE SILVER SHADOW AND BENTLEY T SERIES RIGHT-HAND DRIVE CARS PRIOR TO CAR SERIAL NUMBER SRH 5001

TSD Publication 2432

© Rolls-Royce Limited 1969

Rolls-Royce policy is one of continuous engineering improvement and the right is reserved to revise the contents of this publication without prior notice.

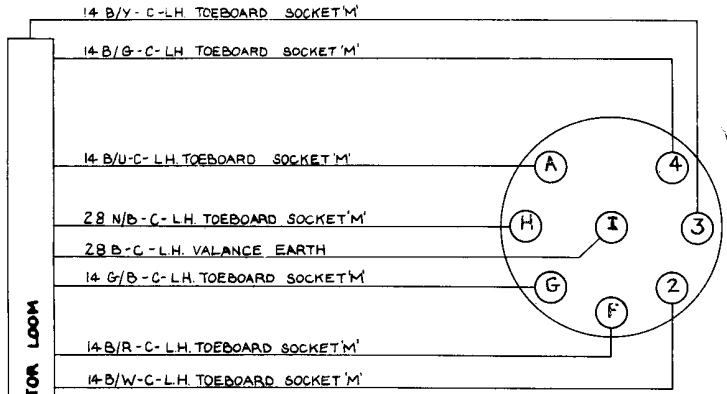

GEARBOX ACTUATOR LOOM

GEARBOX ACTUATOR

GEAR SELECTOR LOOM

L.H. TOEBOARD PLUG AND SOCKET

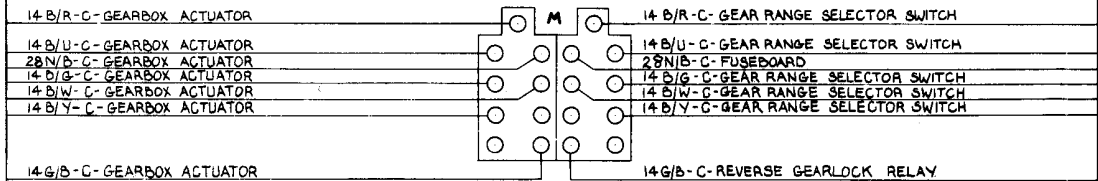

L.H. VALANCE EARTH POINT



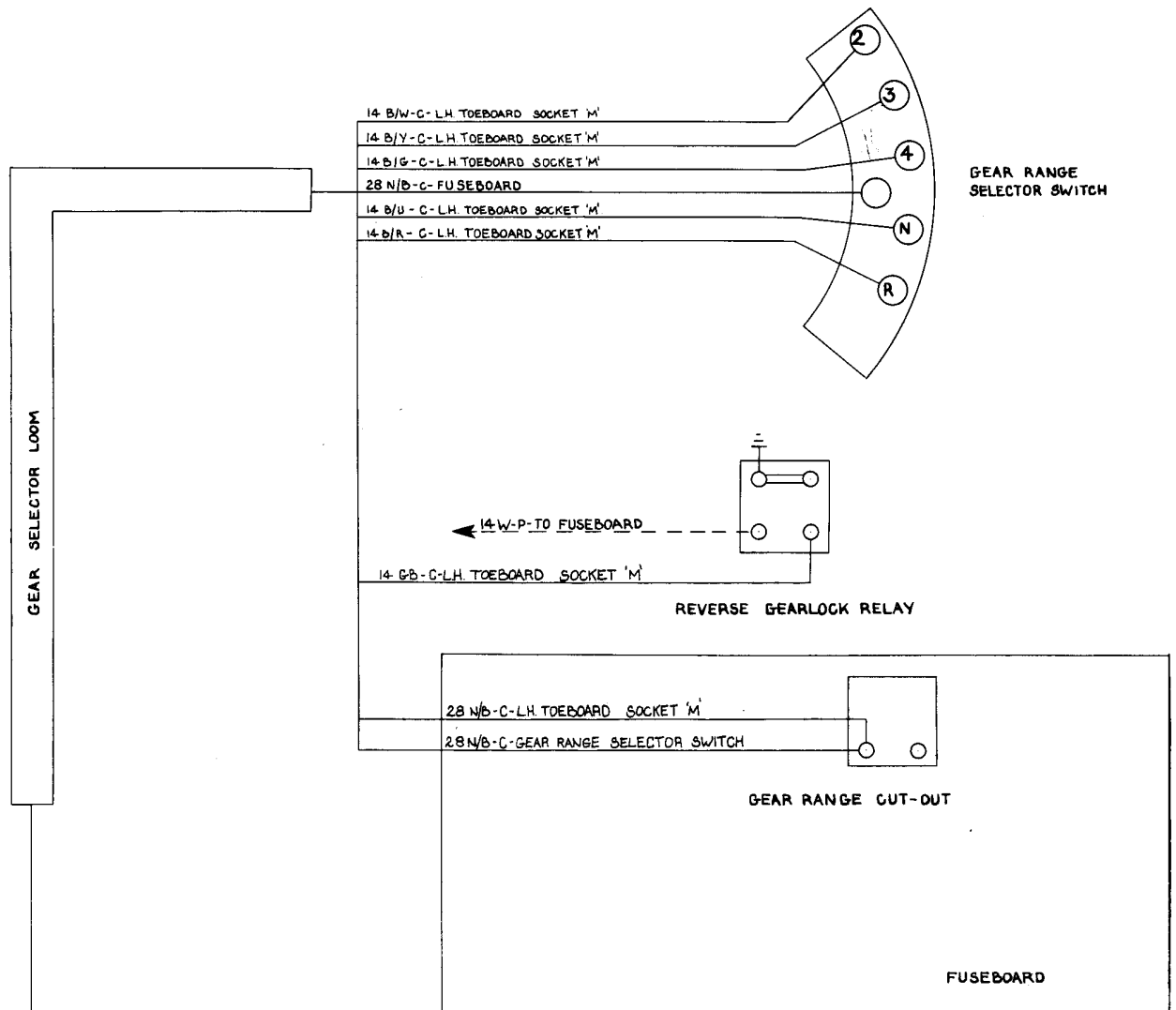

KEY TO DIAGRAM

CABLE COLOURS

B-BLACK	N-BROWN	R-RED
P-PURPLE	U-BLUE	G-GREEN
Y-YELLOW	W-WHITE	S-SLATE

EXAMPLE ○ — UP-P

BLUE BASE WITH PURPLE TRACER PLASTIC COVERED
 FIRST COLOUR AS BASE SECOND COLOUR AS TRACER
 SUFFIX P - PLASTIC COVERED CABLE
 SUFFIX C - COTTON COVERED CABLE

GEAR RANGE SELECTOR SWITCH

GEAR RANGE SELECTOR SWITCH

GEAR RANGE SELECTOR SWITCH

GEAR RANGE SELECTOR SWITCH

GEAR RANGE SELECTOR SWITCH

REVERSE GEARLOCK RELAY

PRACTICAL WIRING DIAGRAM

SHEET 8

AIR CONDITIONING UNIT

ROLLS-ROYCE SILVER SHADOW AND BENTLEY T SERIES RIGHT-HAND DRIVE CARS PRIOR TO CAR SERIAL NUMBER SRH 5001

TSD Publication 2432

© Rolls-Royce Limited 1969

Rolls-Royce policy is one of continuous engineering improvement and the right is reserved to revise the contents of this publication without prior notice.

R.H. VALANCE LOOM

R.H. TOEBOARD PLUG AND SOCKET

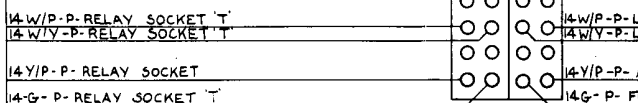

KEY TO DIAGRAM

CABLE COLOURS

B BLACK	N BROWN	R RED
P PURPLE	U BLUE	G GREEN
Y YELLOW	W WHITE	S SLATE

EXAMPLE

UP-P

BLUE BASE WITH PURPLE TRACER. PLASTIC COVERED
FIRST COLOUR AS BASE
SECOND COLOUR AS TRACER
SUFFIX P- PLASTIC COVERED CABLE
SUFFIX G- COTTON COVERED CABLE

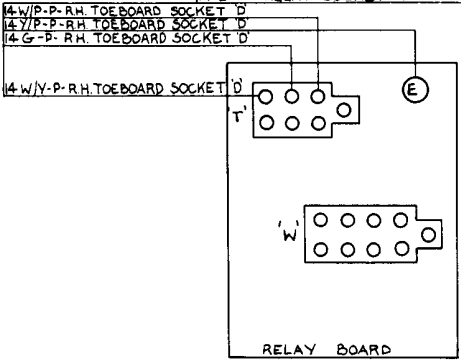

UPPER TEMPERATURE FLAP ACTUATOR

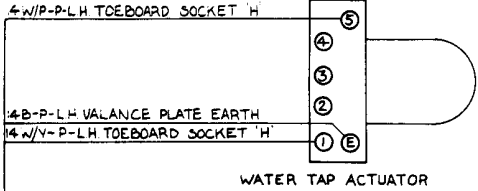
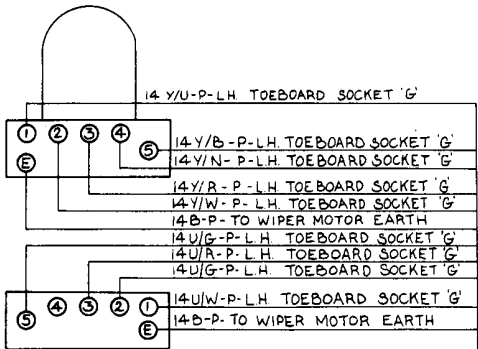

L.H. VALANCE LOOM

ELECTRICALLY HEATED

UPPER QUANTITY FLAP ACTUATOR

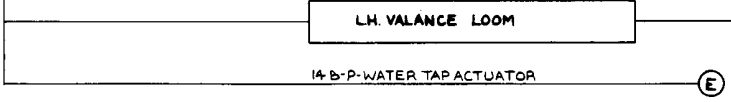
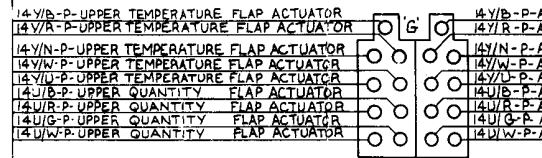

L.H. TOEBOARD PLUGS AND SOCKETS

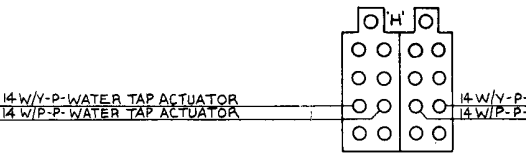

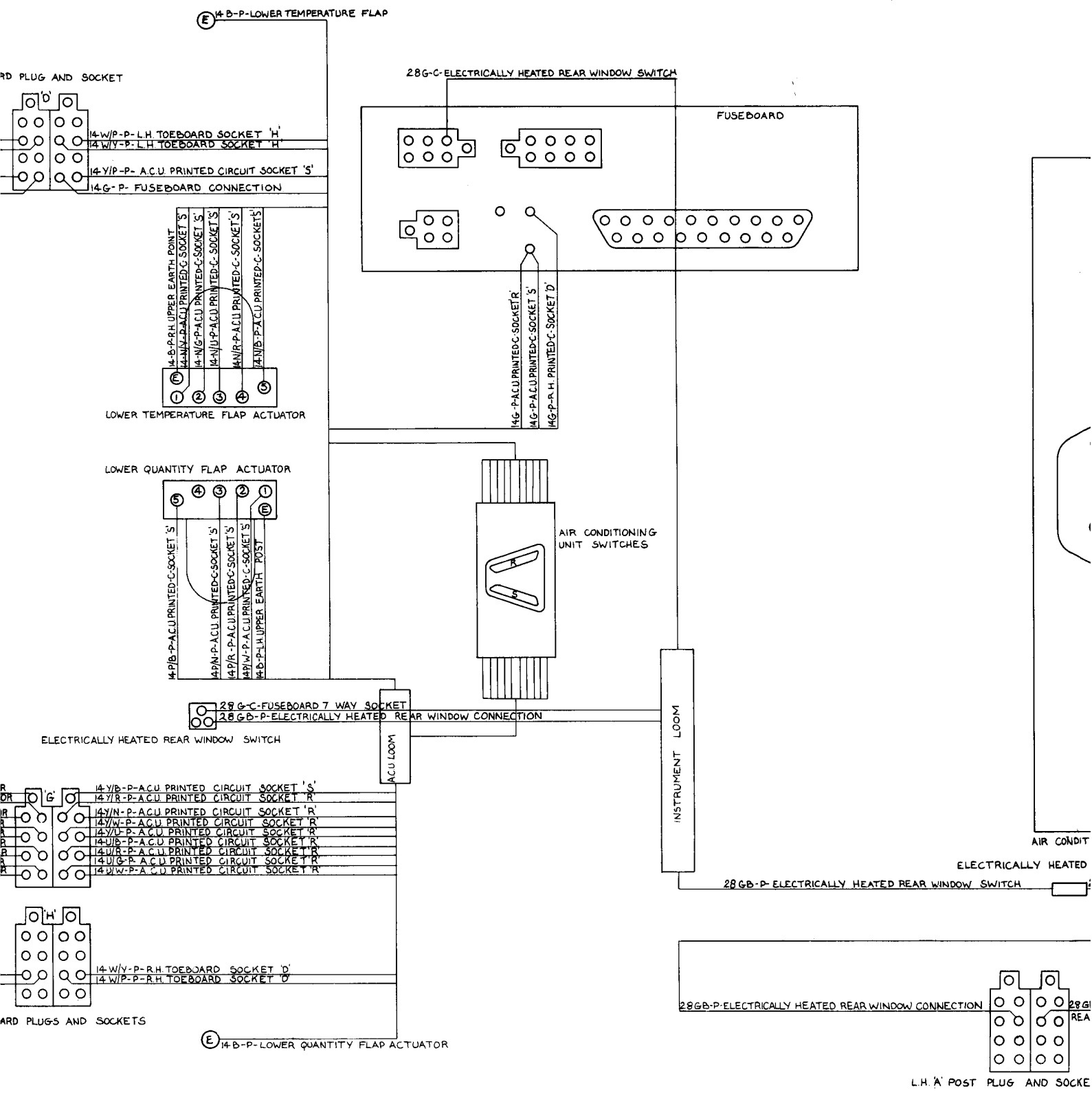

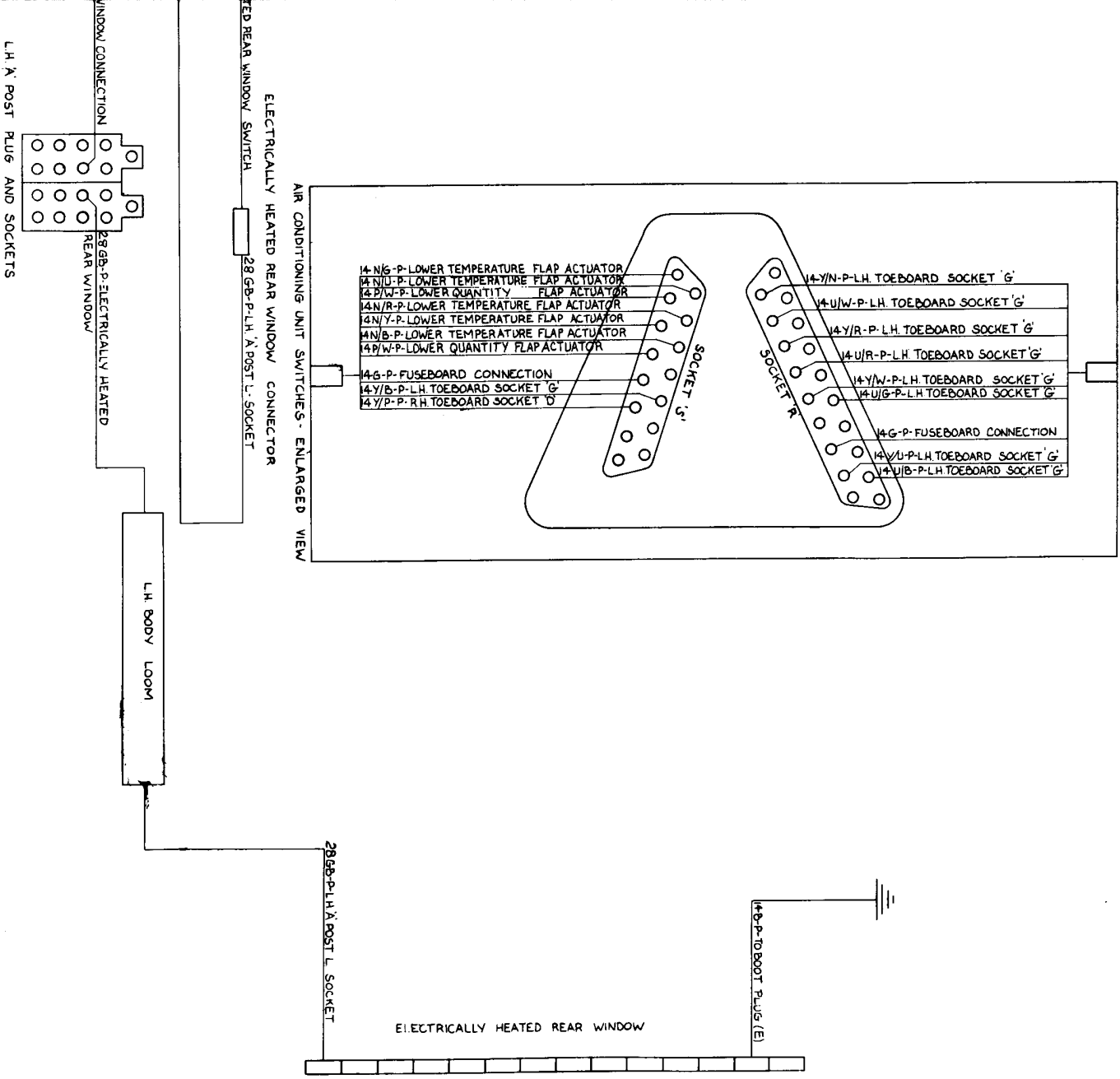

PRACTICAL WIRING DIAGRAM

SHEET 9

RADIO RECIEVER & SPEAKERS

**ROLLS-ROYCE SILVER SHADOW
AND
BENTLEY T SERIES
RIGHT-HAND DRIVE CARS
PRIOR TO CAR SERIAL NUMBER SRH 5001**

TSD Publication 2432

© Rolls-Royce Limited 1969

Rolls-Royce policy is one of continuous engineering improvement and the right is reserved to revise the contents of this publication without prior notice.

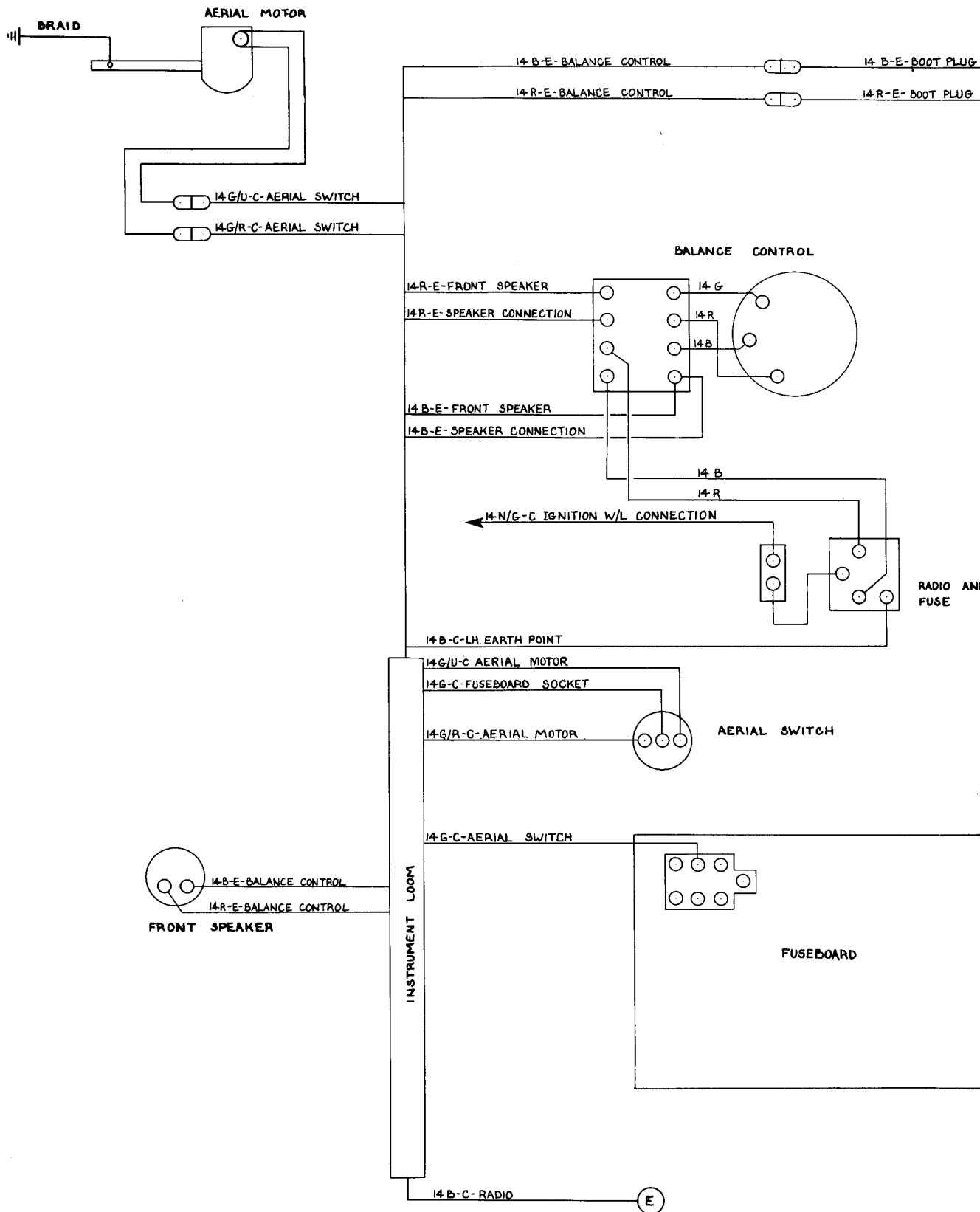

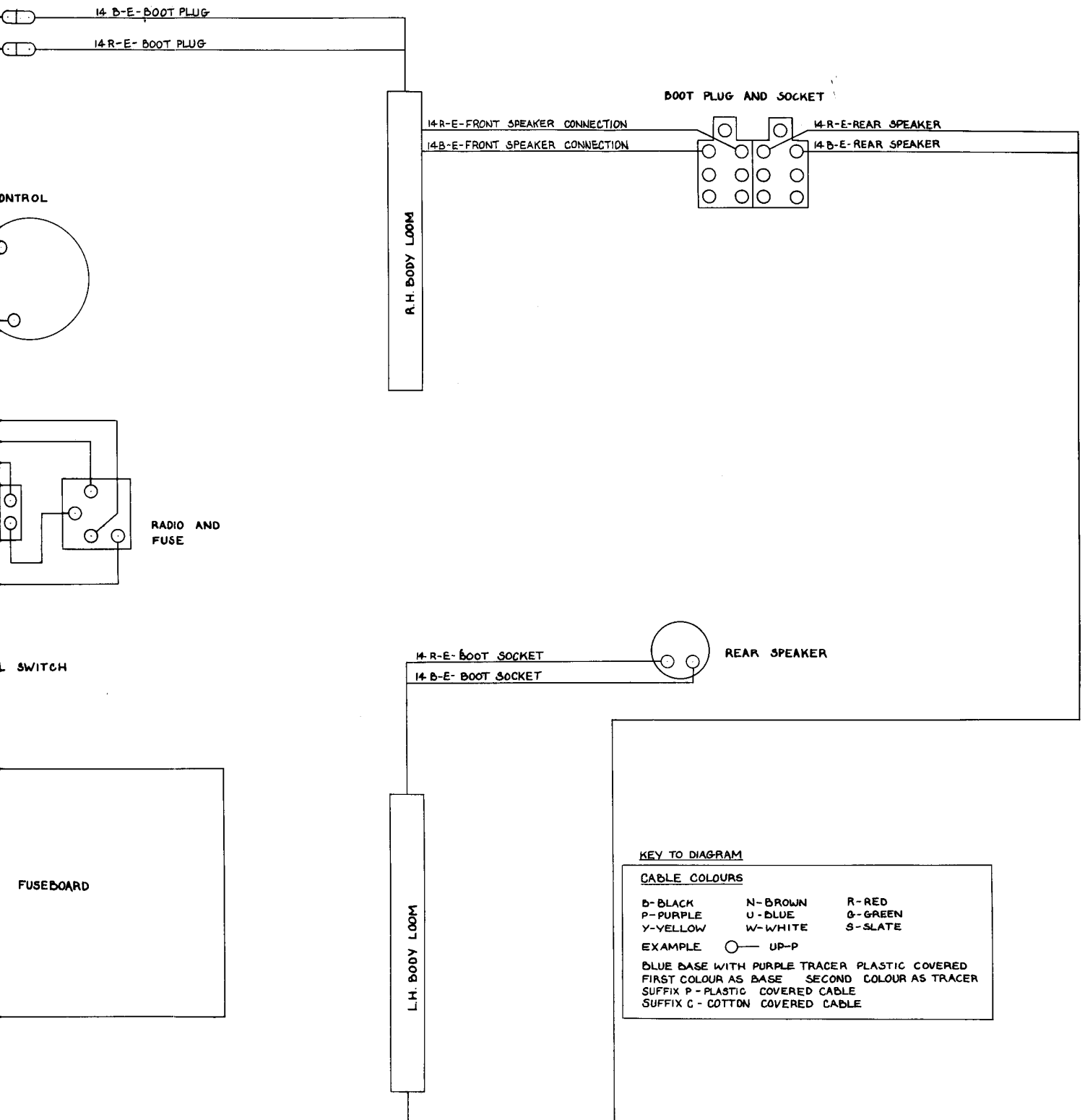

PRACTICAL WIRING DIAGRAM

SHEET 10

INTERIOR LIGHTING

ROLLS-ROYCE SILVER SHADOW AND BENTLEY T SERIES RIGHT-HAND DRIVE CARS PRIOR TO CAR SERIAL NUMBER SRH 5001

TSD Publication 2432

© Rolls-Royce Limited 1969

Rolls-Royce policy is one of continuous engineering improvement and the right is reserved to revise the contents of this publication without prior notice.

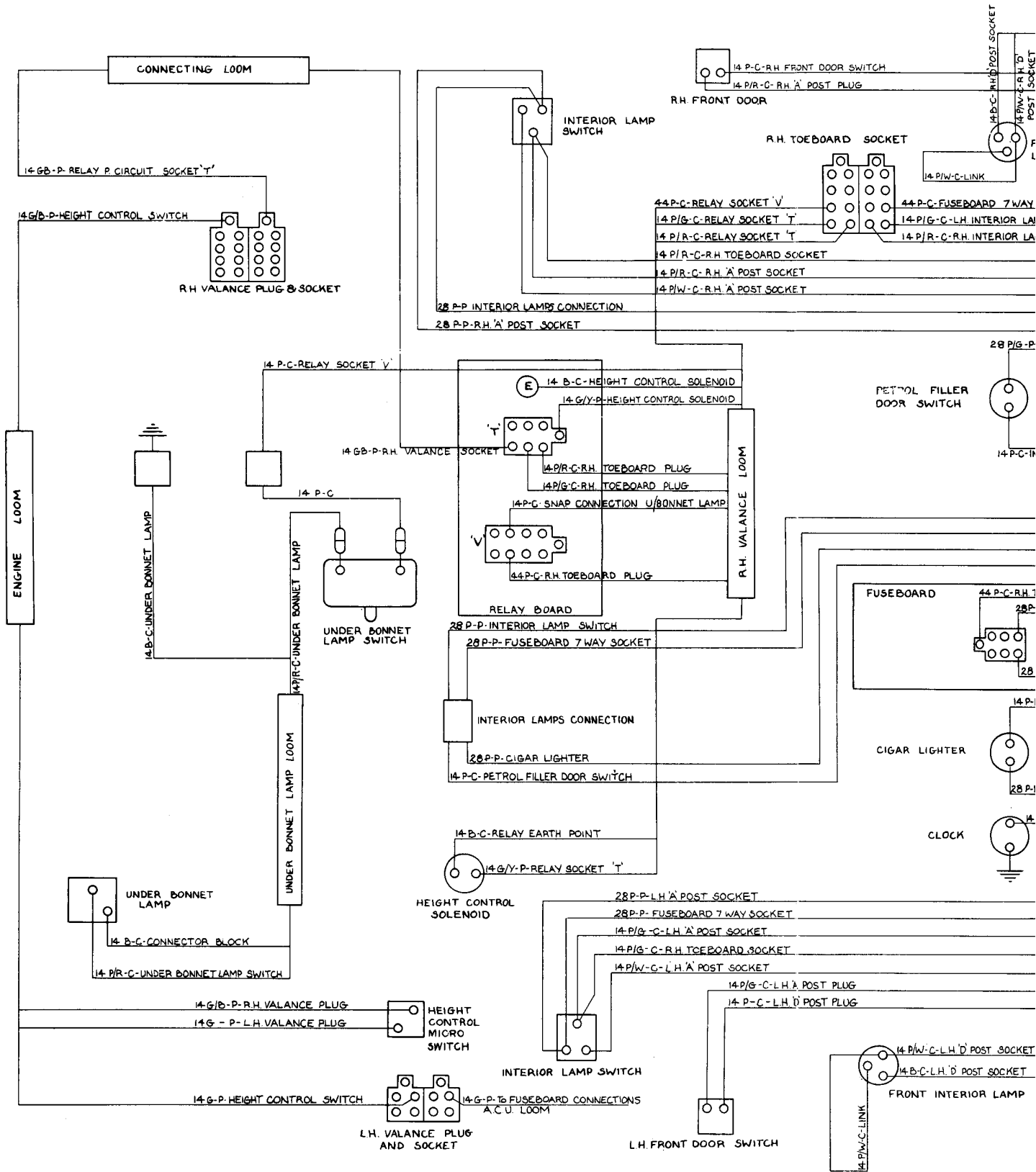

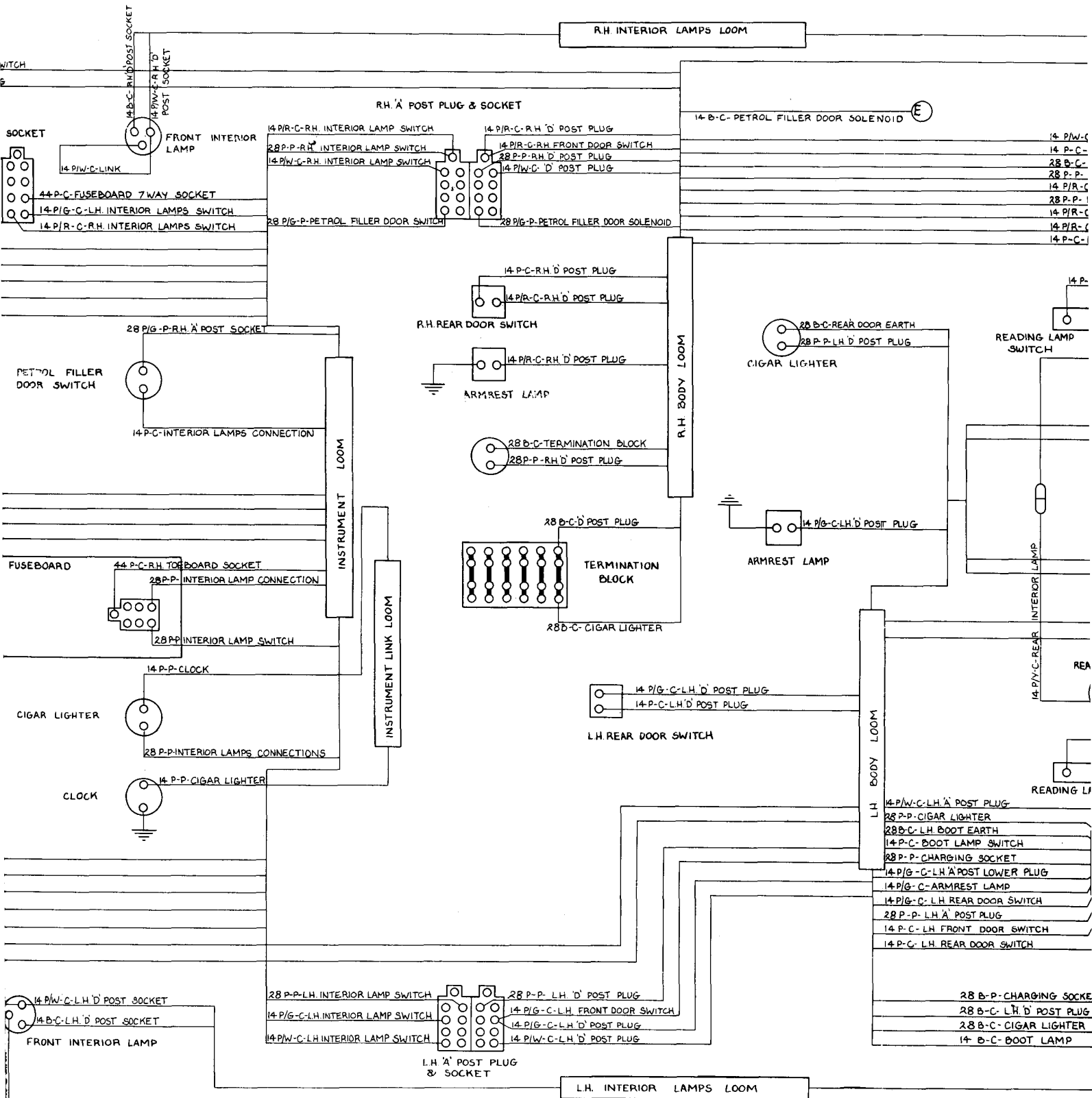

R.H. INTERIOR LAMPS LOOM

R.H. 'A' POST PLUG & SOCKET

L.H. INTERIOR LAMPS LOOM

R.H. BODY LOOM

L.H. BODY LOOM

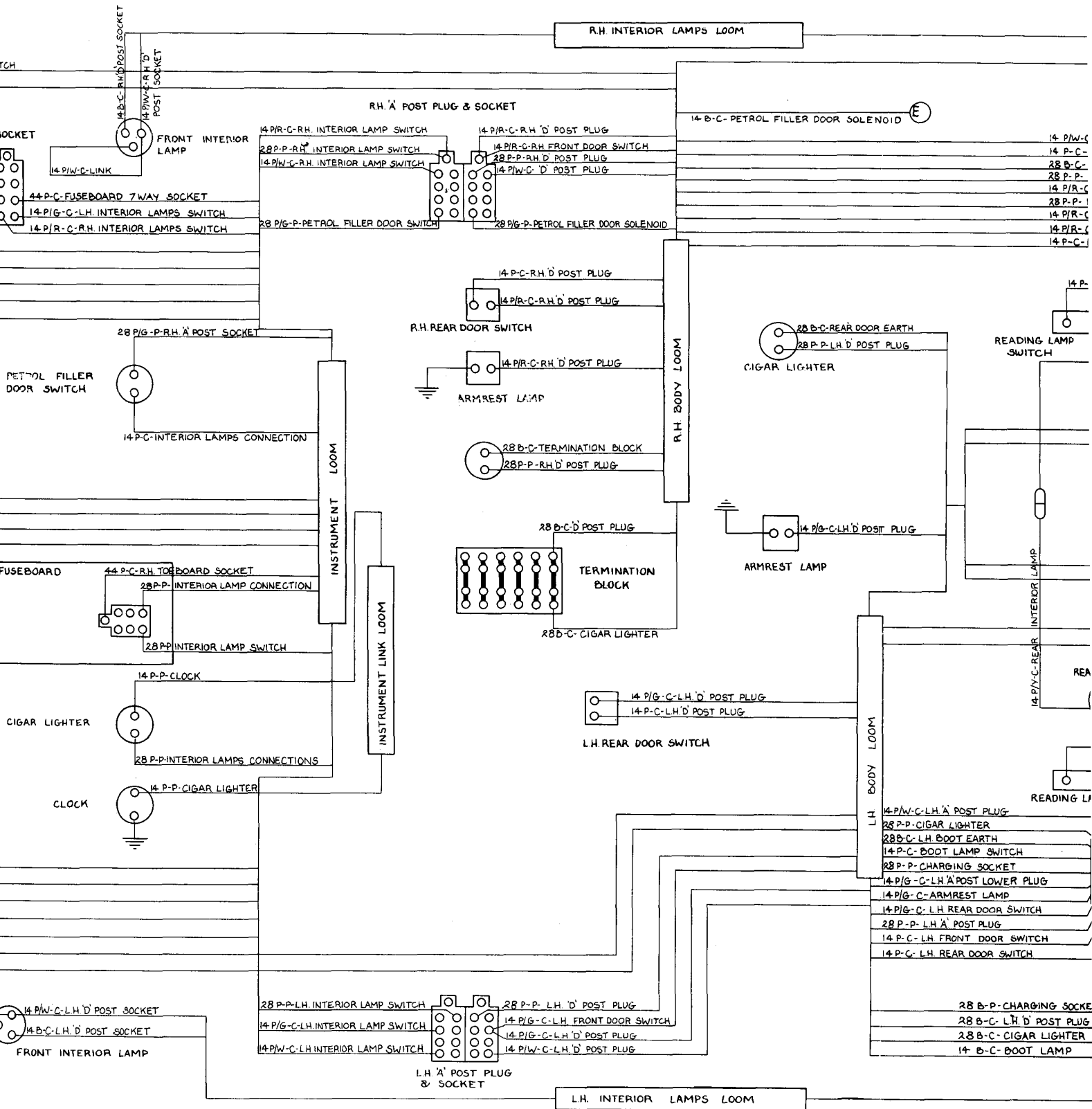

R.H. INTERIOR LAMPS LOOM

R.H. 'A' POST PLUG & SOCKET

L.H. INTERIOR LAMPS LOOM

R.H. BODY LOOM

L.H. BODY LOOM

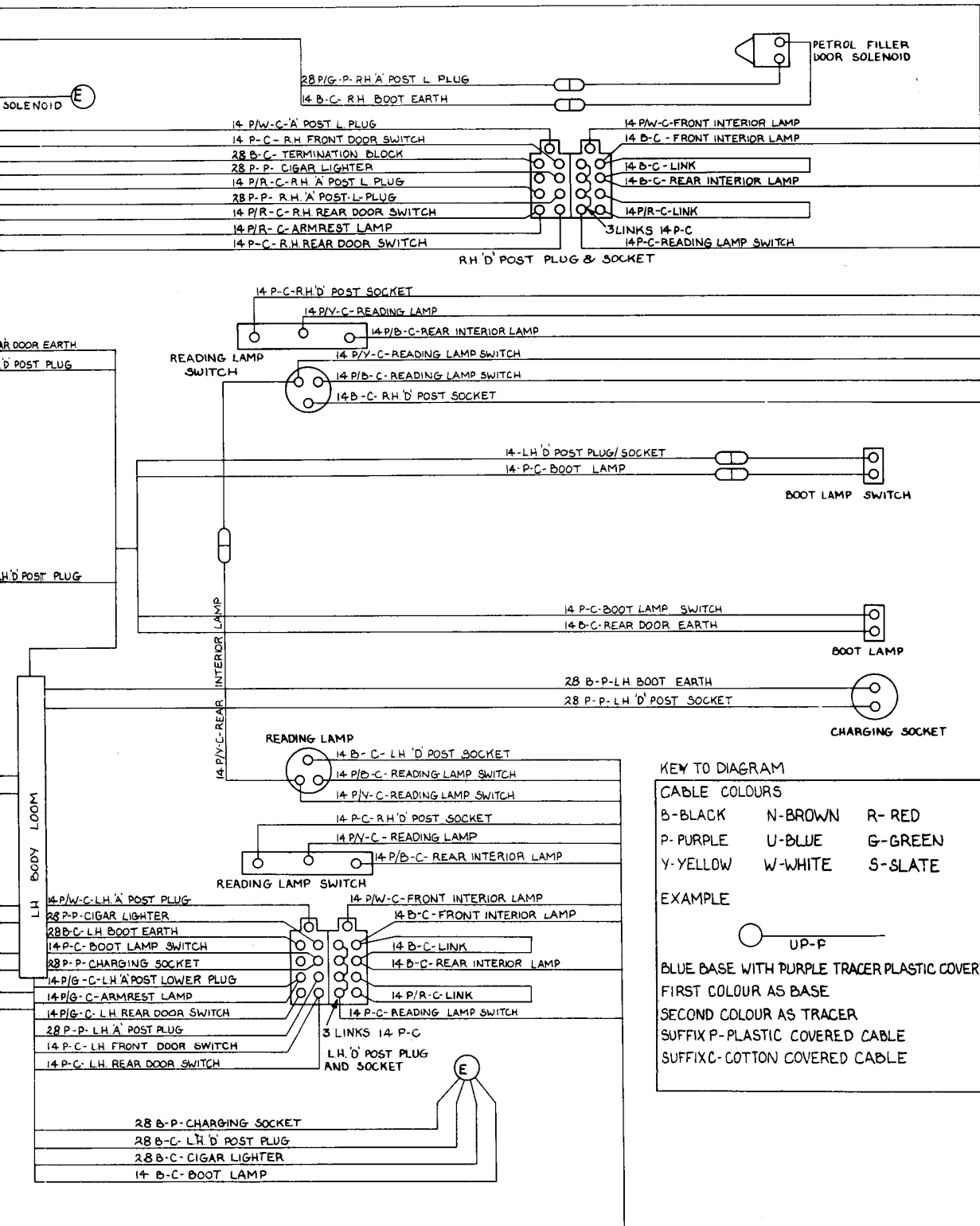

Section 3

RIGHT-HAND DRIVE CARS FROM SERIAL NUMBER 5001 TO 6000

APPLICATION

Theoretical

SHEET No

1

Printed in England

September 1970

T.S.D 2476

THEORETICAL WIRING DIAGRAM

ROLLS-ROYCE SILVER SHADOW AND BENTLEY T SERIES RIGHT-HAND DRIVE STANDARD CARS (Car Serial Numbers 5001-6000)

TSD Publication 2481

© Rolls-Royce Limited (1968)

Rolls-Royce policy is one of continuous engineering improvement and the right is reserved to revise the contents of this publication without prior notice.

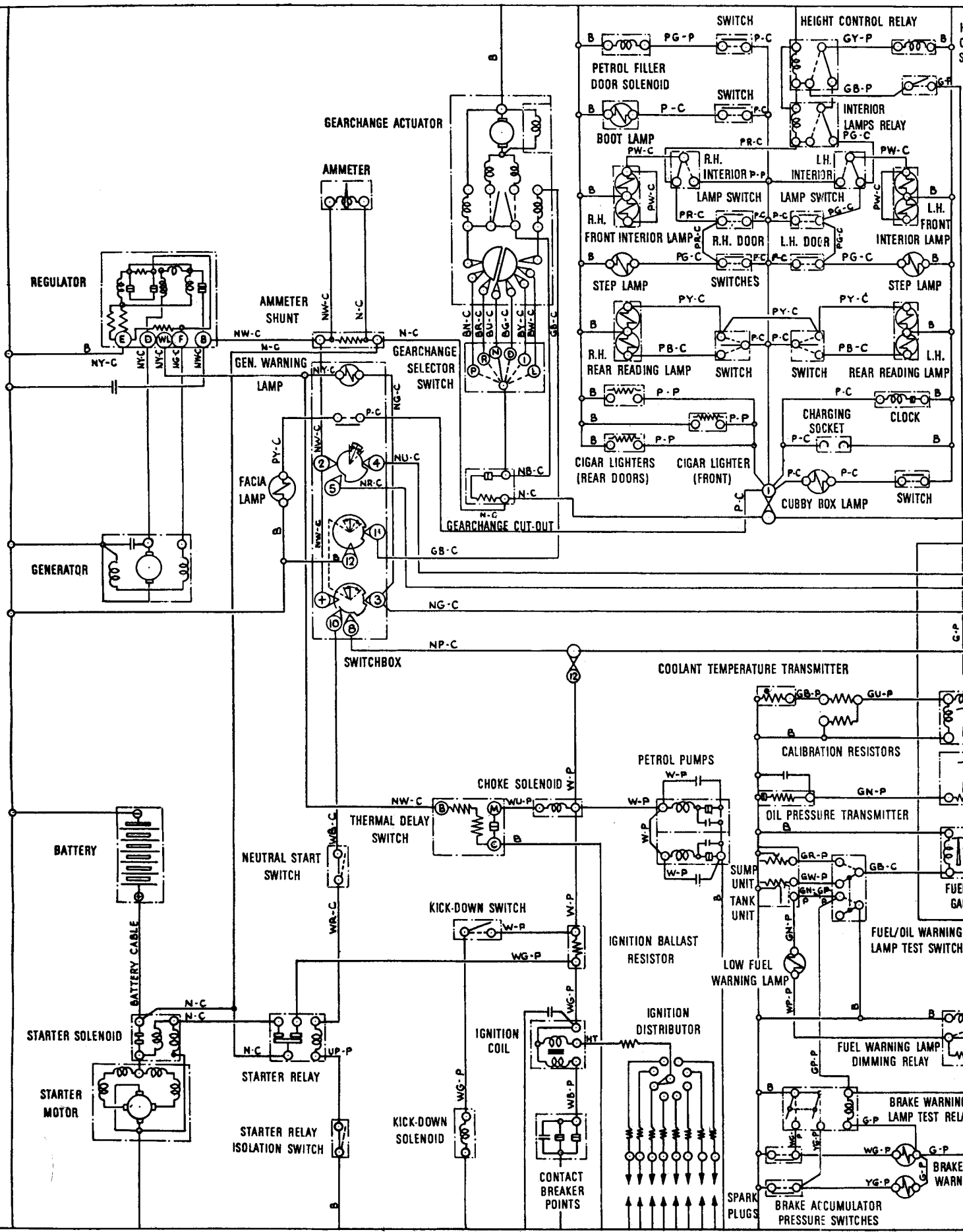

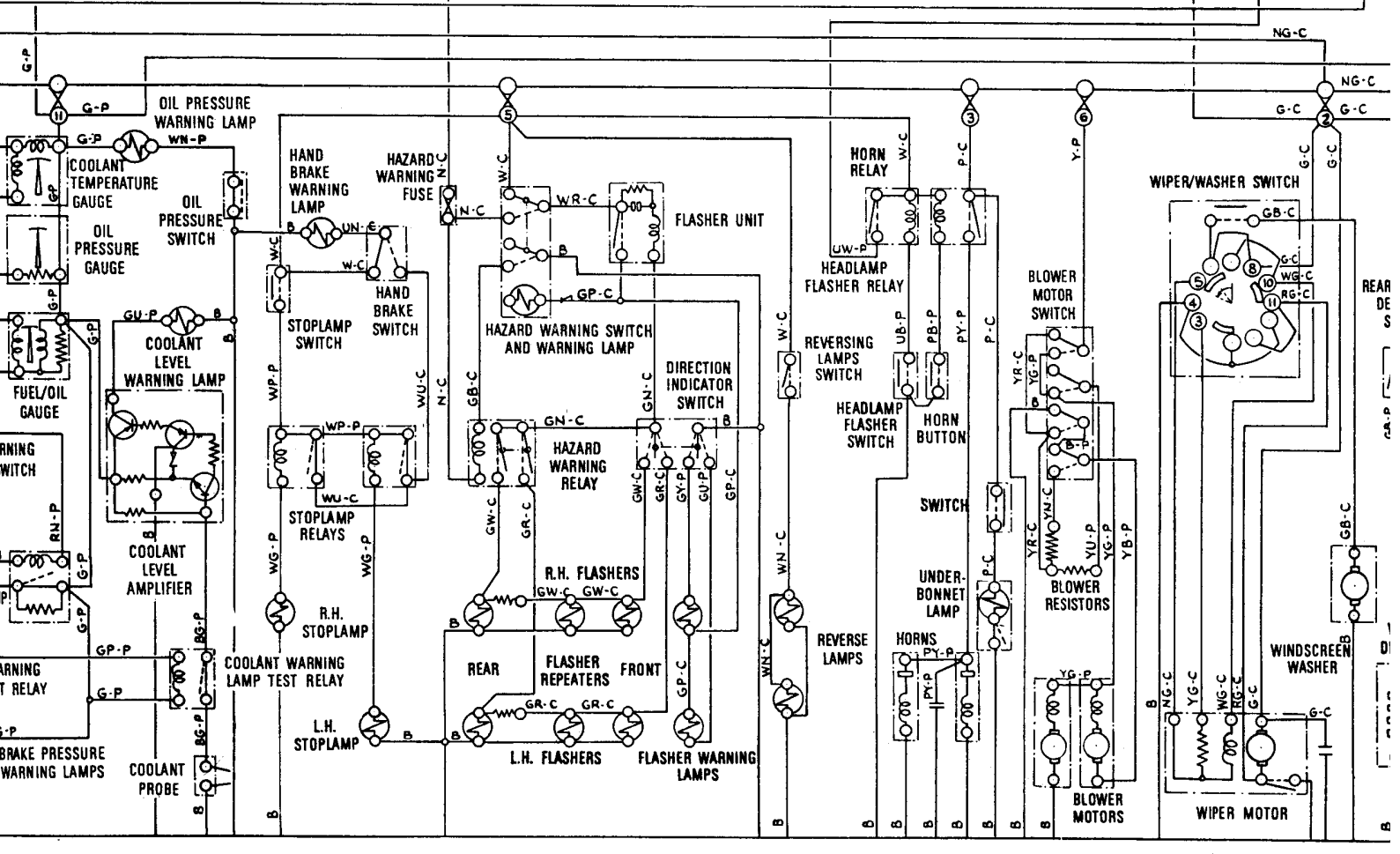
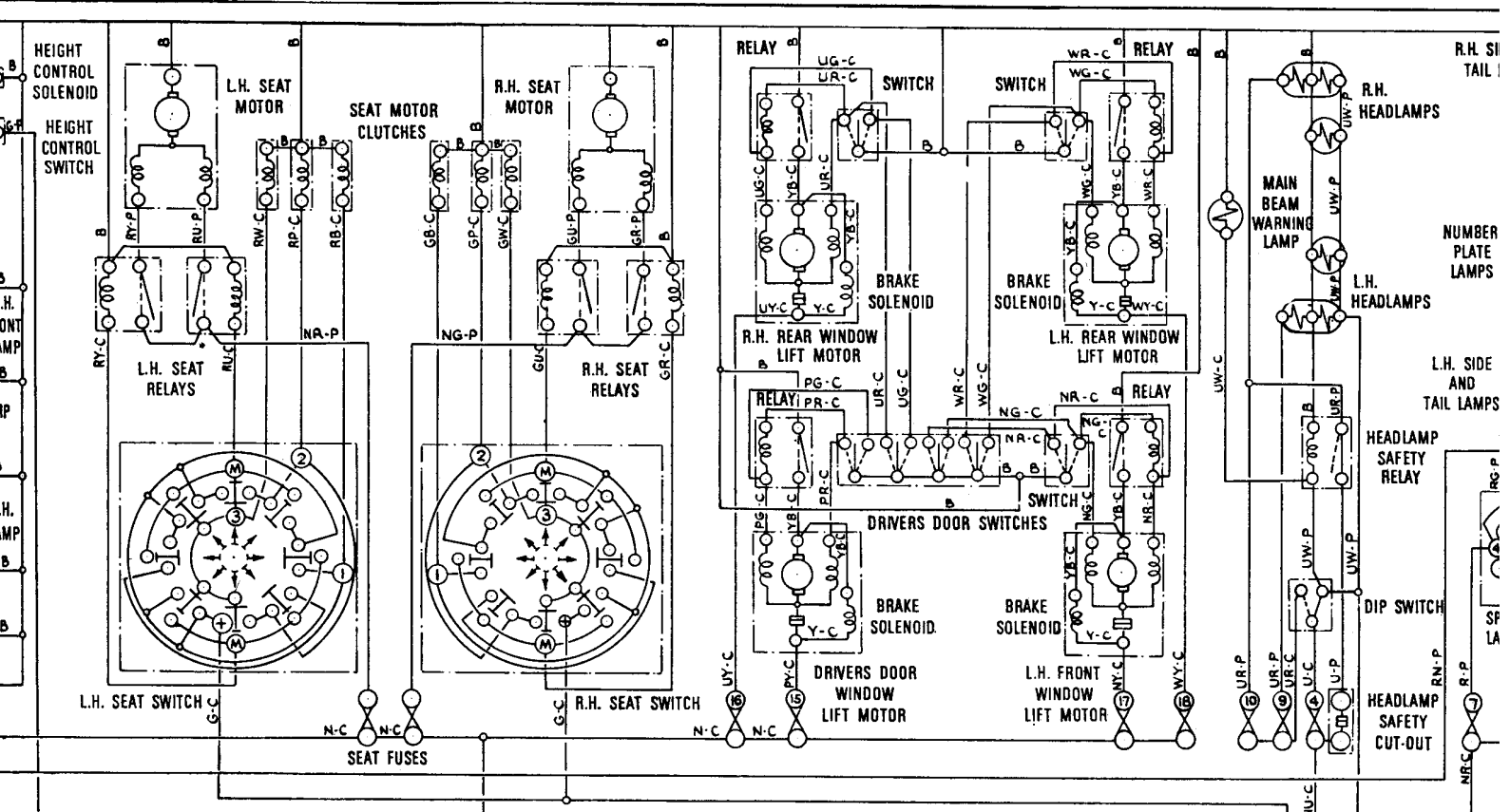

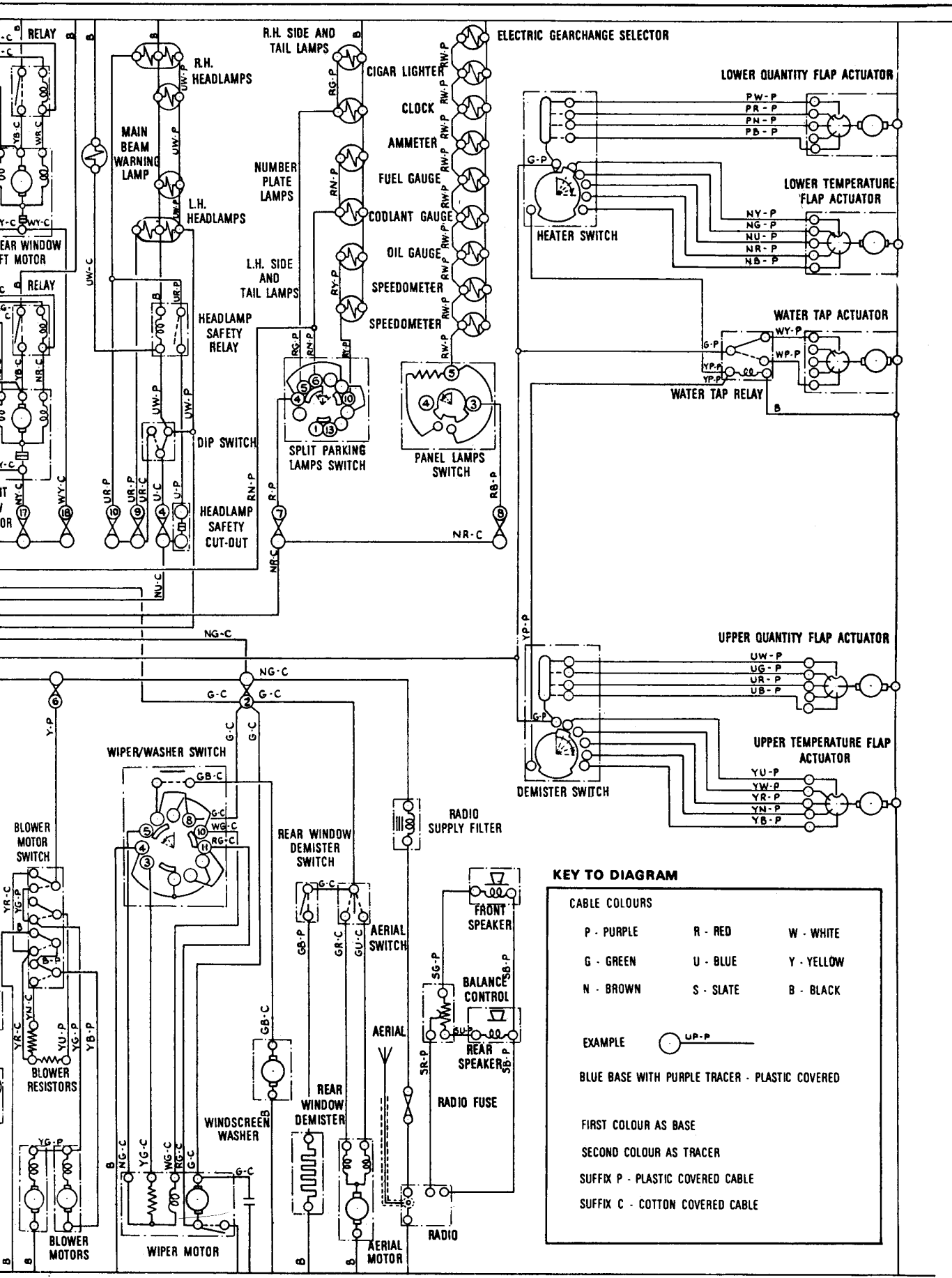

Section 4

LEFT-HAND DRIVE CARS FROM SERIAL NUMBER 6000 TO 9000

APPLICATION

Theoretical

SHEET No

1

Printed in England

September 1970

T.S.D. 2476

THEORETICAL WIRING DIAGRAM

ROLLS-ROYCE SILVER SHADOW AND BENTLEY T SERIES LEFT-HAND DRIVE CARS (A.F.S.S.)

TSD Publication 2442

© Rolls-Royce Limited (1968)

Rolls-Royce policy is one of continuous engineering improvement and the right is reserved to revise the contents of this publication without prior notice.

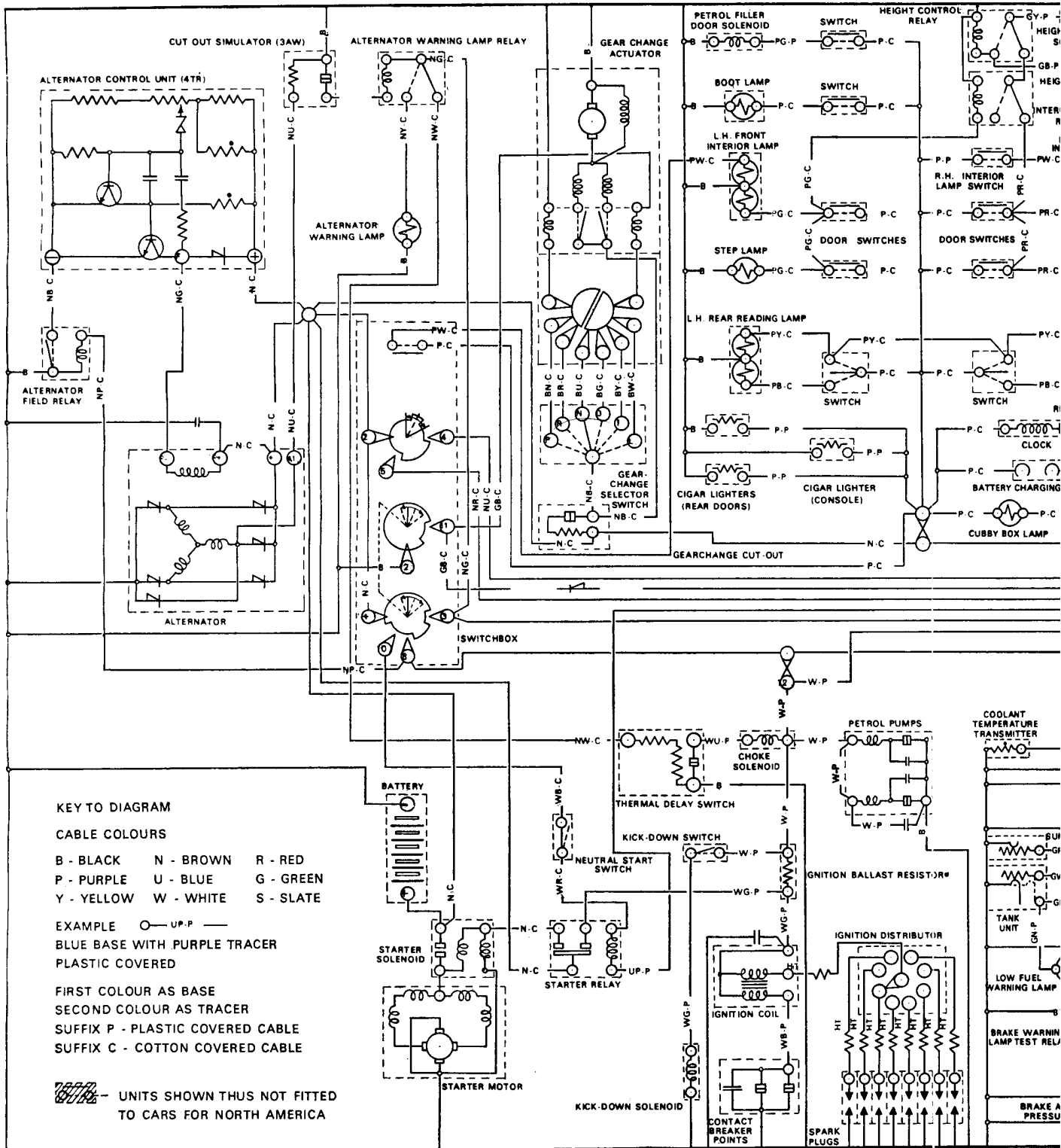

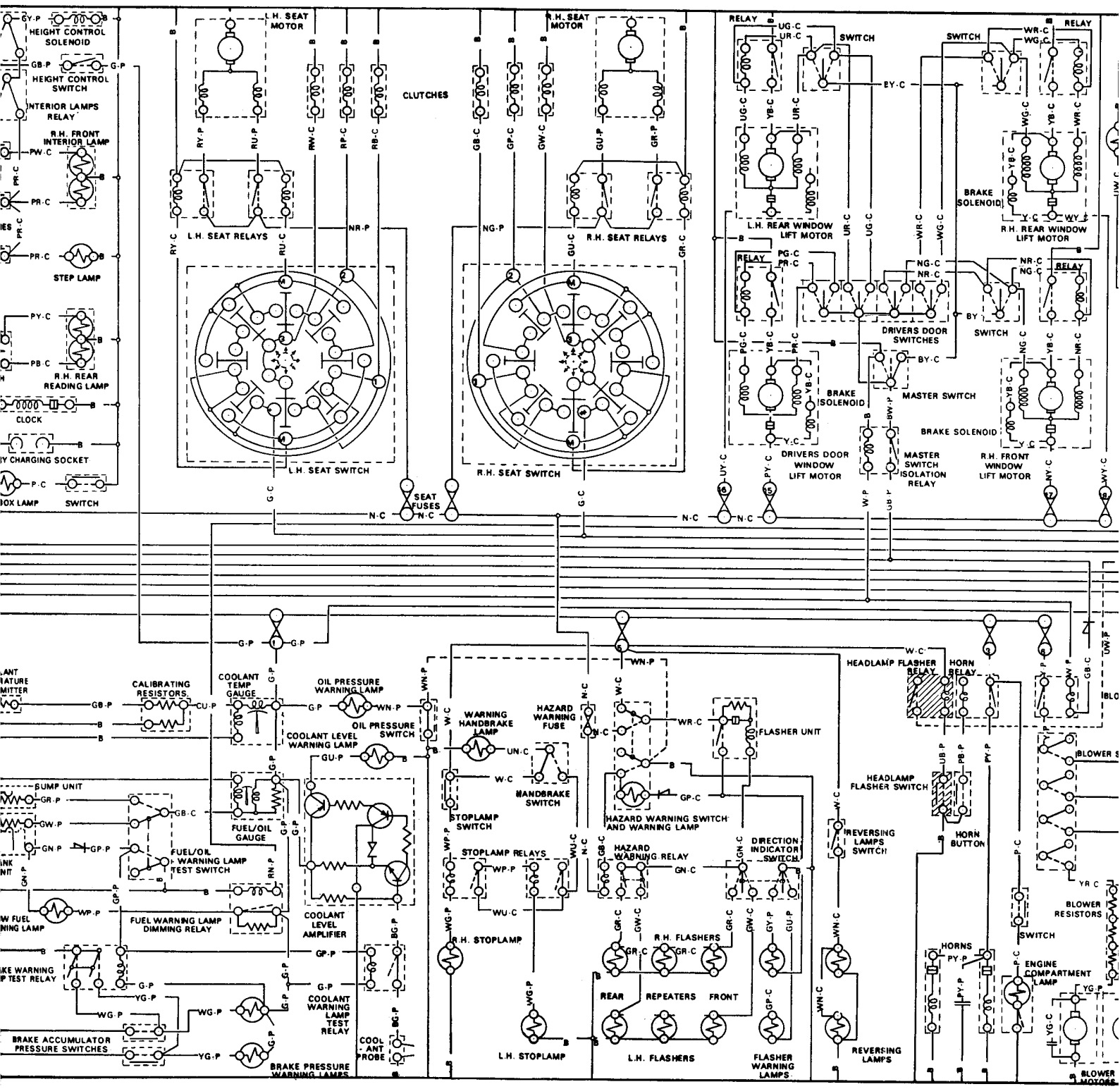

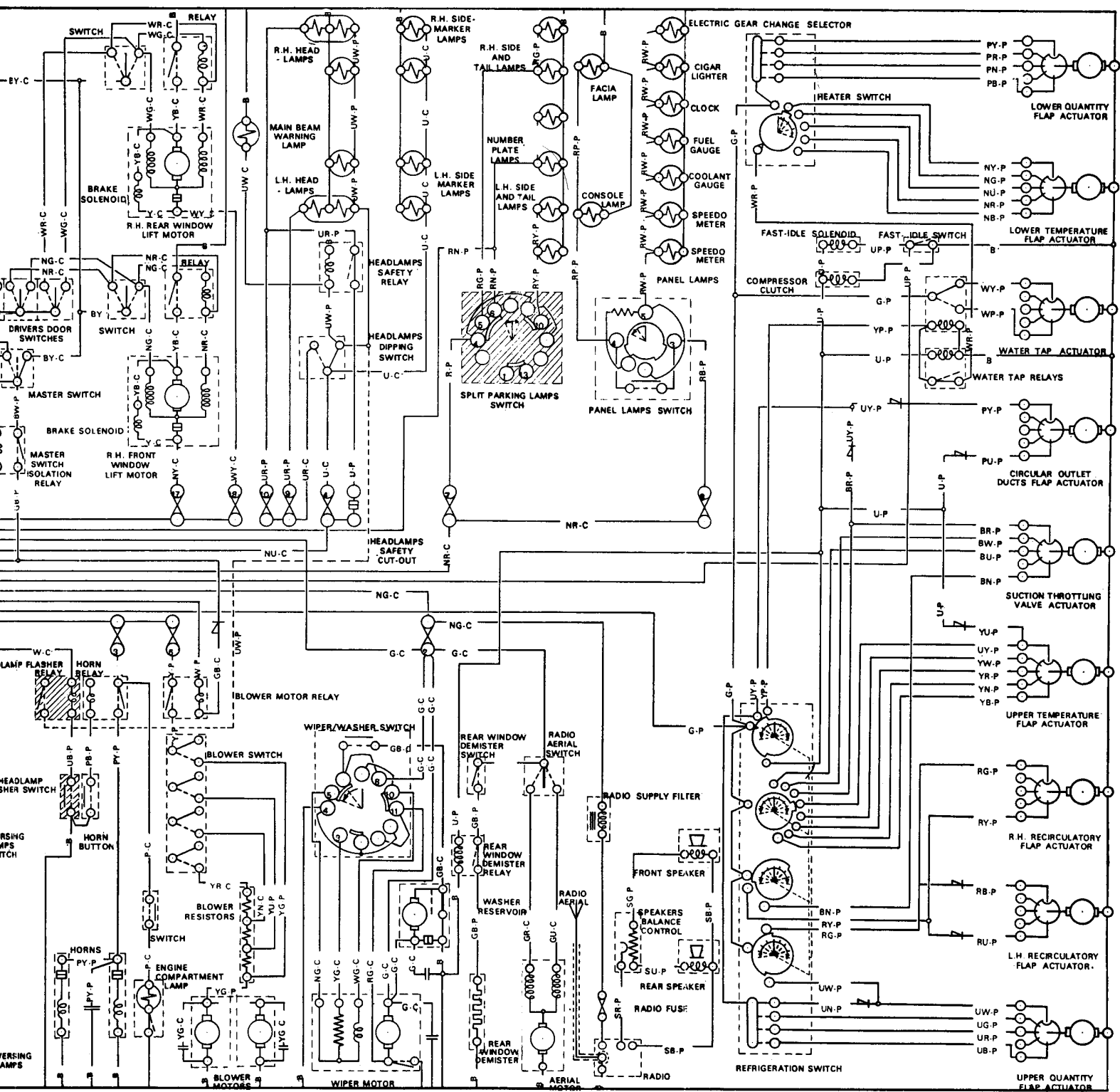

Section 5

LEFT-HANDDRIVE CARS FROM SERIAL NUMBER 6000 TO 9000

APPLICATION	SHEET No
Engine Compartment Looms and Exterior Lighting Looms	1
Bulkhead Toe-board and Instrument Panel Looms	2
Centre Console and Electrically Operated Seat Looms	3
Electrically Operated Windows, Luggage Compartment, and Side and Rear Exterior Lighting Looms	4

PRACTICAL WIRING DIAGRAM

SHEET I
ENGINE COMPARTMENT LOOMS AND
EXTERIOR LIGHTING LOOMS

ROLLS-ROYCE SILVER SHADOW
AND
BENTLEY T SERIES
LEFT-HAND DRIVE CARS

(Car Serial Numbers 6000-9000)

TSD Publication 2463

© Rolls-Royce Limited (1968)

Rolls-Royce policy is one of continuous engineering improvement and the right is reserved to revise the contents of this publication without prior notice

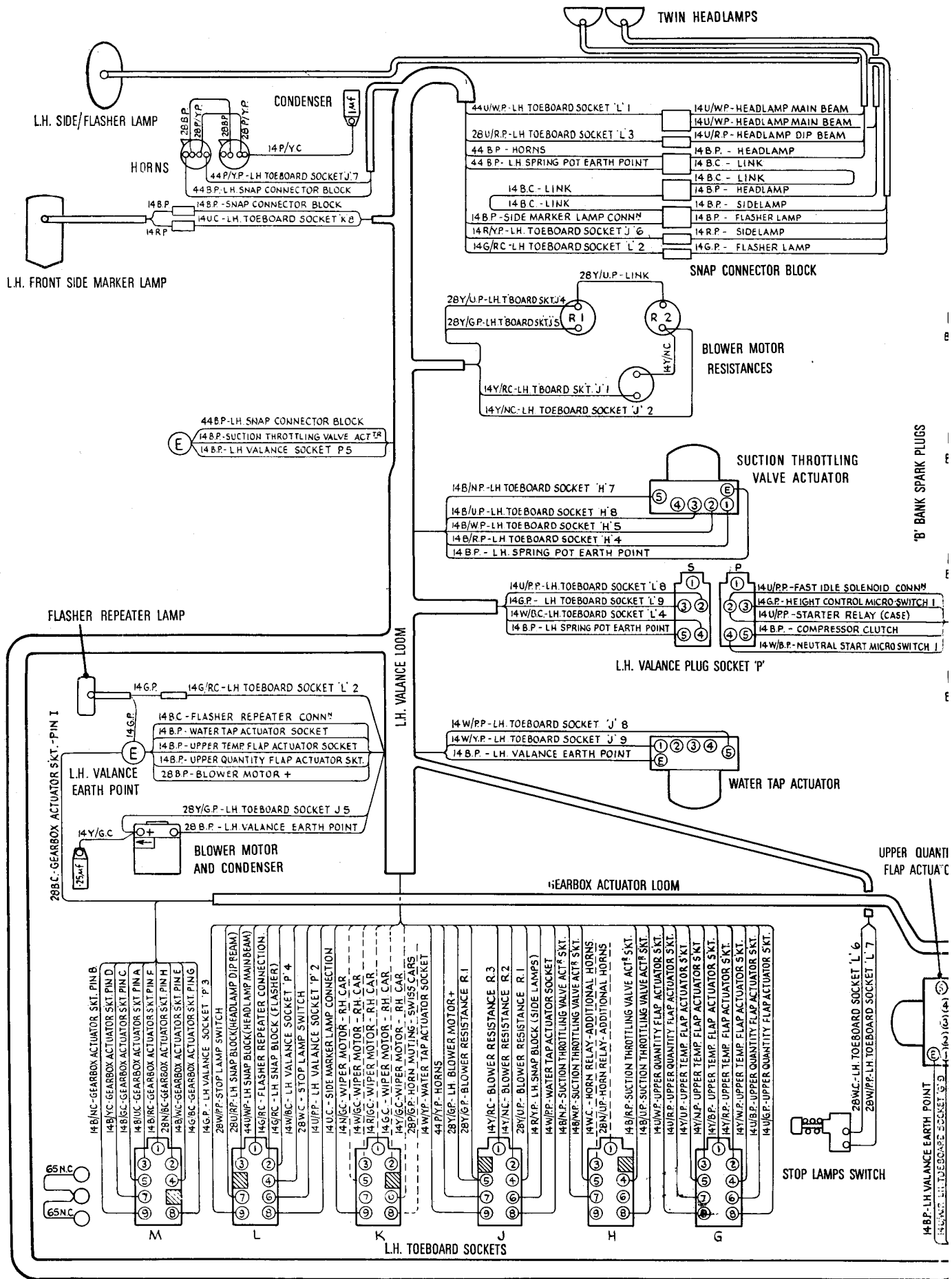

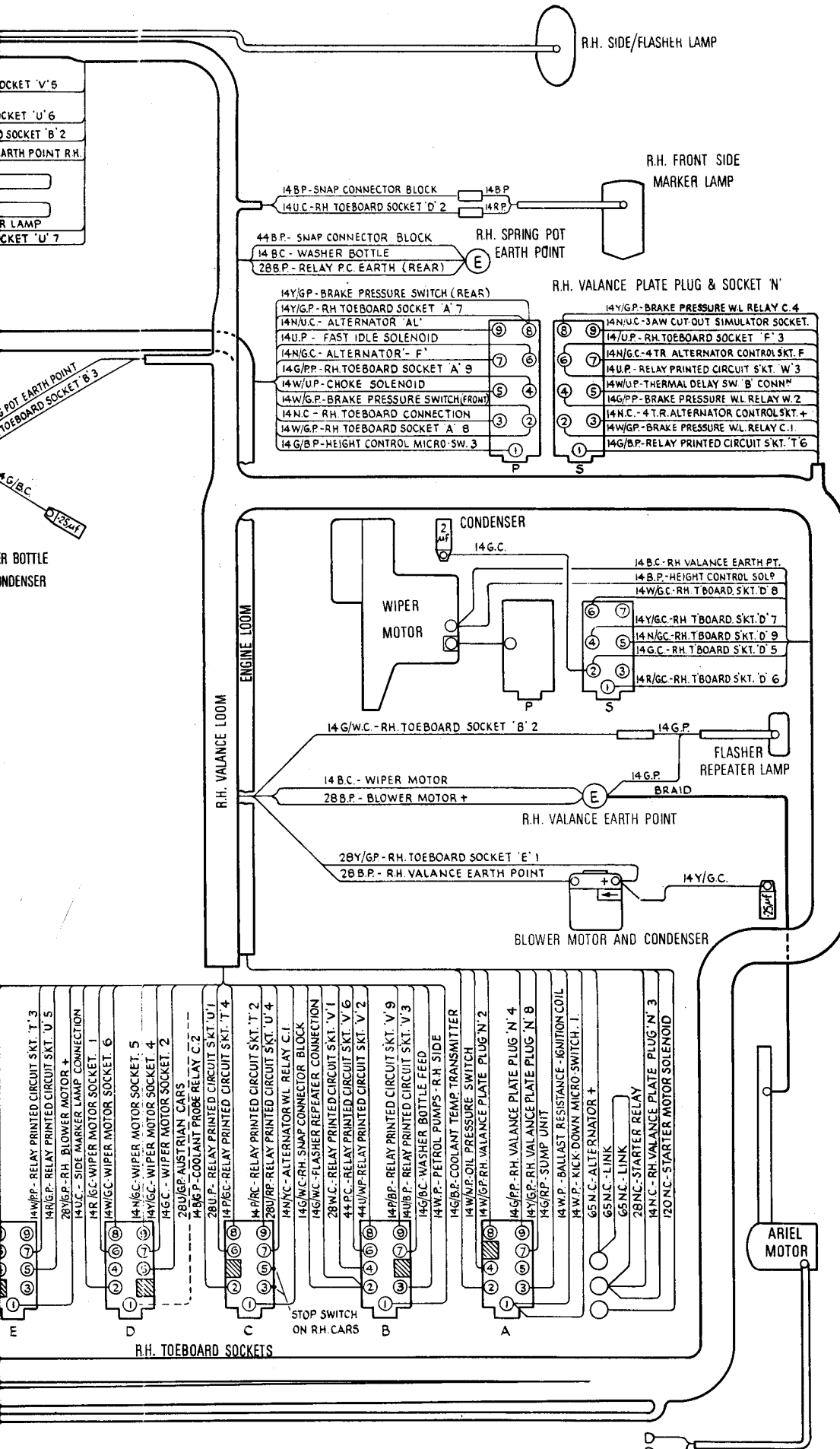

- SOCKET 'V' 5
- SOCKET 'U' 6
- SOCKET 'B' 2
- EARTH POINT R.H.
- R LAMP
- SOCKET 'U' 7

- 14BP - SNAP CONNECTOR BLOCK
- 14UC - RH TOEBOARD SOCKET 'D' 2
- 44BP - SNAP CONNECTOR BLOCK
- 14BC - WASHER BOTTLE
- 28BP - RELAY P.C. EARTH (REAR)
- 14Y/GP - BRAKE PRESSURE SWITCH (REAR)
- 14Y/GP - RH TOEBOARD SOCKET 'A' 7
- 14N/C - ALTERNATOR 'AL'
- 14U/P - FAST IDLE SOLENOID
- 14N/GC - ALTERNATOR - 'F'
- 14G/PP - RH TOEBOARD SOCKET 'A' 9
- 14W/UP - CHOKE SOLENOID
- 14W/GP - BRAKE PRESSURE SWITCH (FRONT)
- 14N/C - RH TOEBOARD CONNECTION
- 14W/GP - RH TOEBOARD SOCKET 'A' 8
- 14G/BP - HEIGHT CONTROL MICRO-SW. 3
- 14Y/GP - BRAKE PRESSURE WL RELAY C. 4
- 14N/C - 3AW CUT-OUT SIMULATOR SOCKET.
- 14U/P - RH TOEBOARD SOCKET 'F' 3
- 14N/GC - 4TR ALTERNATOR CONTROL SKT. F
- 14U/P - RELAY PRINTED CIRCUIT S'KT. W' 3
- 14W/UP - THERMAL DELAY SW 'B' CONN'
- 14G/PP - BRAKE PRESSURE WL RELAY W. 2
- 14N/C - 4 T.R. ALTERNATOR CONTROL SKT. +
- 14W/GP - BRAKE PRESSURE WL RELAY C. 1
- 14G/BP - RELAY PRINTED CIRCUIT S'KT. T' 6

- POT EARTH POINT TOEBOARD SOCKET 'B' 3
- G/B.C.
- R BOTTLE
- CONDENSER

- R BOTTLE
- CONDENSER

- 14W/PP - RELAY PRINTED CIRCUIT S'KT. T' 3
- 14N/GP - RELAY PRINTED CIRCUIT S'KT. U' 5
- 28Y/GP - RH. BLOWER MOTOR +
- 14UC - SIDE MARKER LAMP CONNECTION
- 14R/GC - WIPER MOTOR SOCKET. 1
- 14W/GC - WIPER MOTOR SOCKET. 6
- 14N/GC - WIPER MOTOR SOCKET. 5
- 14Y/GC - WIPER MOTOR SOCKET. 4
- 14G/C - WIPER MOTOR SOCKET. 2
- 28U/GP - AUSTRIAN CAPS
- 14BGP - COOLANT PROBE RELAY C' 2
- 28U/P - RELAY PRINTED CIRCUIT S'KT. U' 1
- 14P/GC - RELAY PRINTED CIRCUIT S'KT. T' 4
- 14P/C - RELAY PRINTED CIRCUIT S'KT. T' 2
- 28U/RP - RELAY PRINTED CIRCUIT S'KT. U' 4
- 14N/C - ALTERNATOR WL RELAY C. 1
- 14G/WC - RH. SNAP CONNECTOR BLOCK
- 14G/WC - FLASHER REPEATER CONNECTION
- 28W/C - RELAY PRINTED CIRCUIT S'KT. V' 1
- 44PC - RELAY PRINTED CIRCUIT S'KT. V' 6
- 14U/WP - RELAY PRINTED CIRCUIT S'KT. V' 2
- 14P/BP - RELAY PRINTED CIRCUIT S'KT. V' 9
- 14U/BP - RELAY PRINTED CIRCUIT S'KT. V' 3
- 14G/BP - WASHER BOTTLE FEED
- 14W/P - PETROL PUMPS - R.H. SIDE
- 14G/BP - COOLANT TEMP TRANSMITTER
- 14W/UP - OIL PRESSURE SWITCH
- 14W/GP - RH. VALANCE PLATE PLUG 'N' 2
- 14G/PP - RH. VALANCE PLATE PLUG 'N' 4
- 14Y/GP - RH. VALANCE PLATE PLUG 'N' 8
- 14G/RP - SUMP UNIT
- 14W/P - BALLAST RESISTANCE - IGNITION COIL
- 14W/P - KICK-DOWN MICRO-SWITCH. 1.
- 65N/C - ALTERNATOR +
- 65N/C - LINK
- 65N/C - LINK
- 28NC - STARTER RELAY
- 14N/C - RH VALANCE PLATE PLUG 'N' 3
- 120N/C - STARTER MOTOR SOLENOID

ARIEL MOTOR

ARIEL MOTOR CONNECTIONS

PRACTICAL WIRING DIAGRAM

SHEET 2 BULKHEAD TOE-BOARD AND INSTRUMENT PANEL LOOMS

ROLLS-ROYCE SILVER SHADOW AND BENTLEY T SERIES LEFT-HAND DRIVE CARS

(Car Serial Numbers 6000-9000)

TSD Publication 2463

© Rolls-Royce Limited (1968)

Rolls-Royce policy is one of continuous engineering improvement and the right is reserved to revise the contents of this publication without prior notice

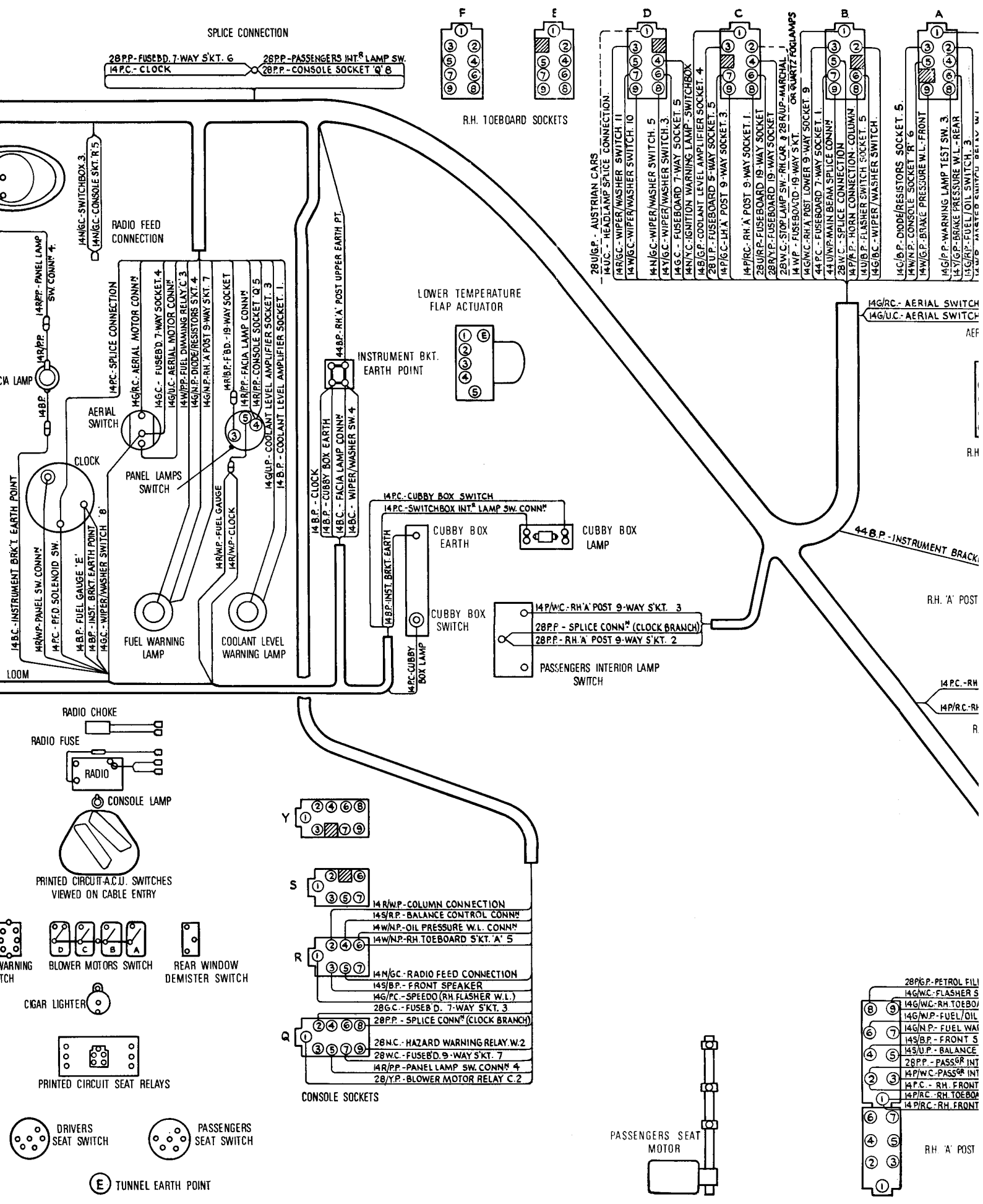

SPICE CONNECTION

28PP-FUSEBD. 7-WAY S'KT. 6
14P/C - CLOCK

28PP-PASSENGERS INT'L LAMP SW.
28PP-CONSOLE SOCKET 'Q' B

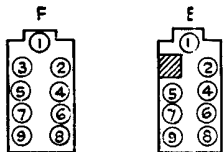

R.H. TOEBOARD SOCKETS

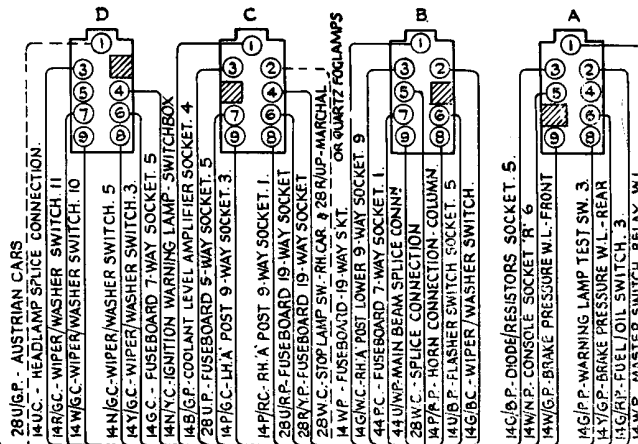

28U/G.P. - AUSTRIAN CARS
14U/C - HEADLAMP SPICE CONNECTION
14R/GC - WIPER/WASHER SWITCH 11
14W/GC - WIPER/WASHER SWITCH 10
14N/GC - WIPER/WASHER SWITCH 5
14Y/GC - WIPER/WASHER SWITCH 3
14G/C - FUSEBOARD 7-WAY SOCKET 5
14N/C - IGNITION WARNING LAMP SWITCHBOX
14B/GP - COOLANT LEVEL AMPLIFIER SOCKET 4
28U/P - FUSEBOARD 5-WAY SOCKET 5
14P/GC - LH 'A' POST 9-WAY SOCKET 3
14P/RC - RH 'A' POST 9-WAY SOCKET 1
28U/RP - FUSEBOARD 19-WAY SOCKET
28R/YP - FUSEBOARD 19-WAY SOCKET
28W/C - STOP LAMP SW. - RH CAR & 28R/UP - MARCHAL 1
14W/P - FUSEBOARD 19-WAY S'KT. OR QUARTZ FLOODLAMPS
14GNC - RH 'A' POST LOWER 9-WAY SOCKET 9
44U/PC - FUSEBOARD 7-WAY SOCKET 1
44U/MP - MAIN BEAM SPICE CONNIN
28W/C - SPICE CONNECTION
14P/P - HORN CONNECTION - COLUMN
14U/B P - FLASHER SWITCH SOCKET 5
14G/BC - WIPER/WASHER SWITCH
14C/B.P. - DIODE/RESISTORS SOCKET 5
14W/N.P. - CONSOLE SOCKET 'R' 6
14W/G.P. - BRAKE PRESSURE W.L. - FRONT
14G/PP - WARNING LAMP TEST SW. 3
14Y/GP - BRAKE PRESSURE W.L. - REAR
14G/RP - FUEL/OIL SWITCH 3
14W/B - MARCHAL 19-WAY S'KT.

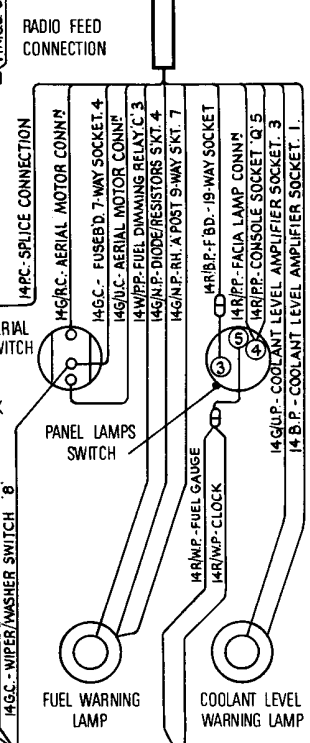

LOWER TEMPERATURE FLAP ACTUATOR

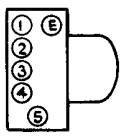

INSTRUMENT BKT. EARTH POINT

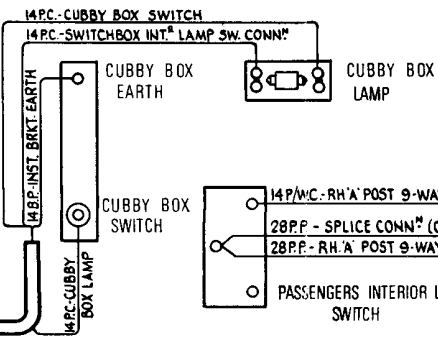
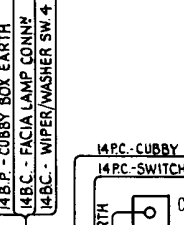

14G/RC - AERIAL SWITCH
14G/UC - AERIAL SWITCH

AEF

R.H.

R.H. 'A' POST

14P/C - RH

14P/RC - R

R

44B.P. - INSTRUMENT BRACKET

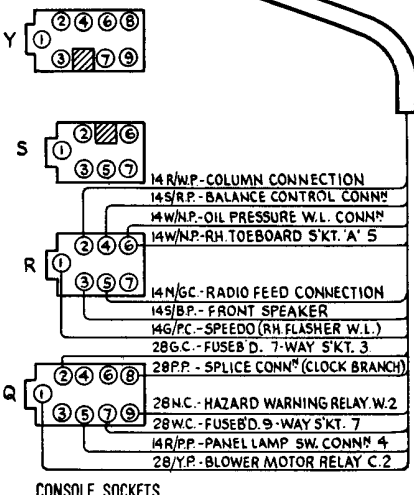
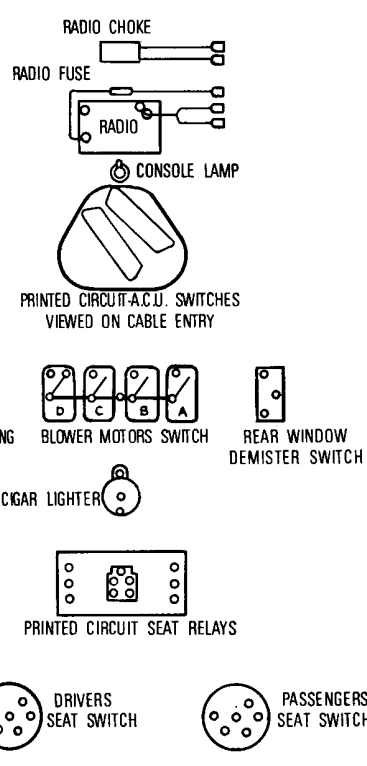

CONSOLE SOCKETS

14R/WP - COLUMN CONNECTION
14S/RP - BALANCE CONTROL CONNIN
14W/WP - OIL PRESSURE W.L. CONNIN
14W/WP - RH TOEBOARD S'KT. 'A' 5
14N/GC - RADIO FEED CONNECTION
14S/BP - FRONT SPEAKER
14G/PC - SPEEDO (RH FLASHER W.L.)
28G/C - FUSEBD. 7-WAY S'KT. 3
28PP - SPICE CONNIN (CLOCK BRANCH)
28NC - HAZARD WARNING RELAY W.2
28WC - FUSEBD. 9-WAY S'KT. 7
14R/PP - PANEL LAMP SW. CONNIN 4
28Y/P - BLOWER MOTOR RELAY C.2

PASSENGERS SEAT MOTOR

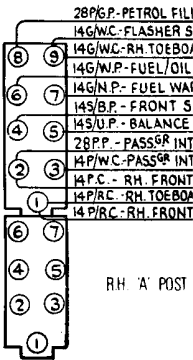
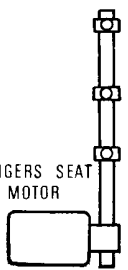

R.H. 'A' POST

E TUNNEL EARTH POINT

PRACTICAL WIRING DIAGRAM

SHEET 3

**CENTRE CONSOLE AND ELECTRICALLY
OPERATED SEAT LOOMS**

**ROLLS-ROYCE SILVER SHADOW
AND**

**BENTLEY T SERIES
LEFT-HAND DRIVE CARS**

(Car Serial Numbers 6000-9000)

TSD Publication 2463

© Rolls-Royce Limited (1968)

Rolls-Royce policy is one of continuous engineering improvement and the right is reserved to revise the contents of this publication without prior notice

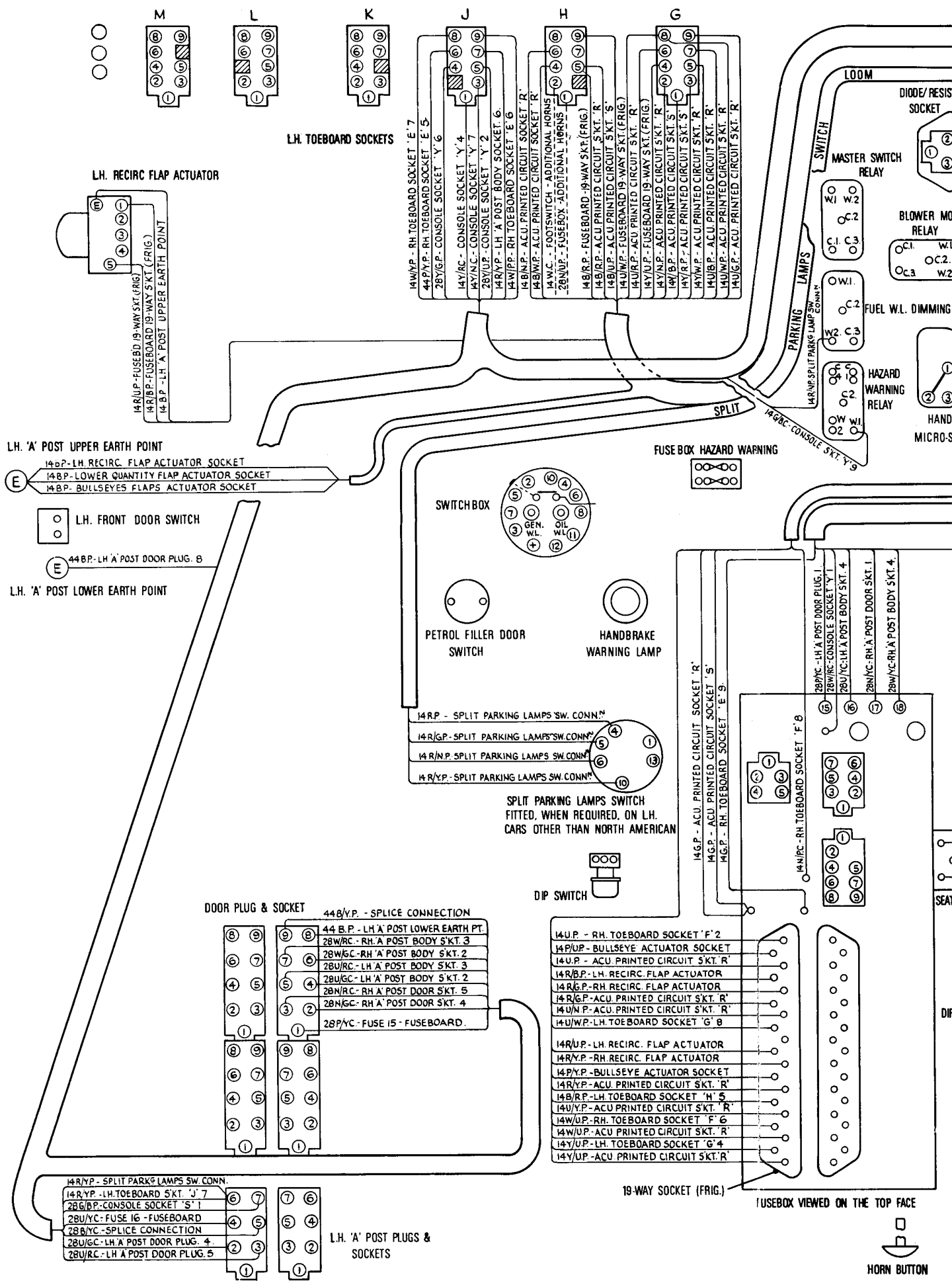

LH. TOEBOARD SOCKETS

- 14M/W/P - RH TOEBOARD SOCKET 'E' 7
- 44P/Y/P - RH TOEBOARD SOCKET 'E' 5
- 28Y/G/P - CONSOLE SOCKET 'Y' 6
- 14Y/R/C - CONSOLE SOCKET 'Y' 4
- 45Y/N/C - CONSOLE SOCKET 'Y' 7
- 28Y/U/P - CONSOLE SOCKET 'Y' 2
- 14R/Y/P - LH 'A' POST BODY SOCKET '6'
- 14W/P/P - RH TOEBOARD SOCKET 'E' 6
- 14B/N/P - ACU PRINTED CIRCUIT SOCKET 'R'
- 14B/W/P - ACU PRINTED CIRCUIT SOCKET 'R'
- 14W/C - FOOTSWITCH - ADDITIONAL HORNS
- 28N/U/P - FUSEBOX - ADDITIONAL HORNS
- 14B/R/P - FUSEBOARD - 19-WAY SKT. (FRIG.)
- 14B/U/P - ACU PRINTED CIRCUIT SKT. 'R'
- 14U/W/P - ACU PRINTED CIRCUIT SKT. 'S'
- 14U/R/P - FUSEBOARD 19-WAY SKT. (FRIG.)
- 14V/W/P - ACU PRINTED CIRCUIT SKT. 'R'
- 14V/N/P - ACU PRINTED CIRCUIT SKT. 'R'
- 14V/B/P - ACU PRINTED CIRCUIT SKT. 'S'
- 14V/R/P - ACU PRINTED CIRCUIT SKT. 'R'
- 14Y/M/P - ACU PRINTED CIRCUIT SKT. 'R'
- 14U/M/P - ACU PRINTED CIRCUIT SKT. 'R'
- 14U/G/P - ACU PRINTED CIRCUIT SKT. 'R'

LH. RECIRC FLAP ACTUATOR

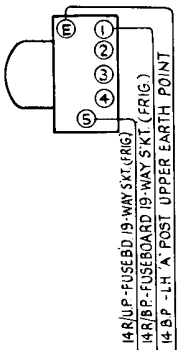

LH. 'A' POST UPPER EARTH POINT

- 14R/P - LH RECIRC. FLAP ACTUATOR SOCKET
- 14B/P - LOWER QUANTITY FLAP ACTUATOR SOCKET
- 14B/P - BULLSEYES FLAPS ACTUATOR SOCKET

LH. FRONT DOOR SWITCH

44B/P - LH 'A' POST DOOR PLUG. 8

LH. 'A' POST LOWER EARTH POINT

SWITCH BOX

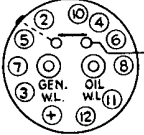

PETROL FILLER DOOR SWITCH

HANDBRAKE WARNING LAMP

- 14R/P - SPLIT PARKING LAMPS SW. CONN.'N
- 14R/G/P - SPLIT PARKING LAMPS SW. CONN.'N
- 14R/N/P - SPLIT PARKING LAMPS SW. CONN.'N
- 14R/Y/P - SPLIT PARKING LAMPS SW. CONN.'N

SPLIT PARKING LAMPS SWITCH
FITTED, WHEN REQUIRED, ON LH.
CARS OTHER THAN NORTH AMERICAN

FUSE BOX HAZARD WARNING



DOOR PLUG & SOCKET

44B/Y/P - SPLICE CONNECTION

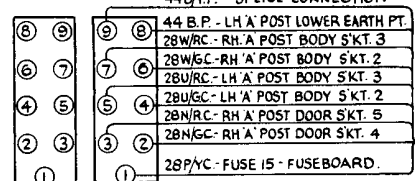

- 14R/Y/P - SPLIT PARKS LAMPS SW. CONN.
- 14R/Y/P - LH TOEBOARD SKT. 'J' 7
- 28B/B/P - CONSOLE SOCKET 'S' 1
- 28U/Y/C - FUSE 16 - FUSEBOARD
- 28B/Y/C - SPLICE CONNECTION
- 28U/G/C - LH 'A' POST DOOR PLUG. 4
- 28U/R/C - LH 'A' POST DOOR PLUG. 5

LH. 'A' POST PLUGS & SOCKETS

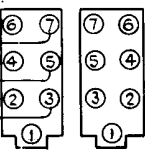

- 14U/P - RH TOEBOARD SOCKET 'F' 2
- 14P/U/P - BULLSEYE ACTUATOR SOCKET
- 14U/P - ACU PRINTED CIRCUIT SKT. 'R'
- 14R/B/P - LH RECIRC. FLAP ACTUATOR
- 14R/G/P - RH RECIRC. FLAP ACTUATOR
- 14R/G/P - ACU PRINTED CIRCUIT SKT. 'R'
- 14U/N/P - ACU PRINTED CIRCUIT SKT. 'R'
- 14U/W/P - LH TOEBOARD SOCKET 'G' 8
- 14R/U/P - LH RECIRC. FLAP ACTUATOR
- 14R/Y/P - RH RECIRC. FLAP ACTUATOR
- 14P/Y/P - BULLSEYE ACTUATOR SOCKET
- 14R/Y/P - ACU PRINTED CIRCUIT SKT. 'R'
- 14B/R/P - LH TOEBOARD SOCKET 'H' 5
- 14U/Y/P - ACU PRINTED CIRCUIT SKT. 'R'
- 14W/U/P - RH TOEBOARD SOCKET 'F' 6
- 14W/U/P - ACU PRINTED CIRCUIT SKT. 'R'
- 14Y/U/P - LH TOEBOARD SOCKET 'G' 4
- 14Y/U/P - ACU PRINTED CIRCUIT SKT. 'R'

19-WAY SOCKET (FRIG.)

FUSEBOX VIEWED ON THE TOP FACE

HORN BUTTON

SPLIT PARKING LAMPS SWITCH CONNECTION

SECONDARY DISTRIBUTION LOOM

A.C.U. LOOM

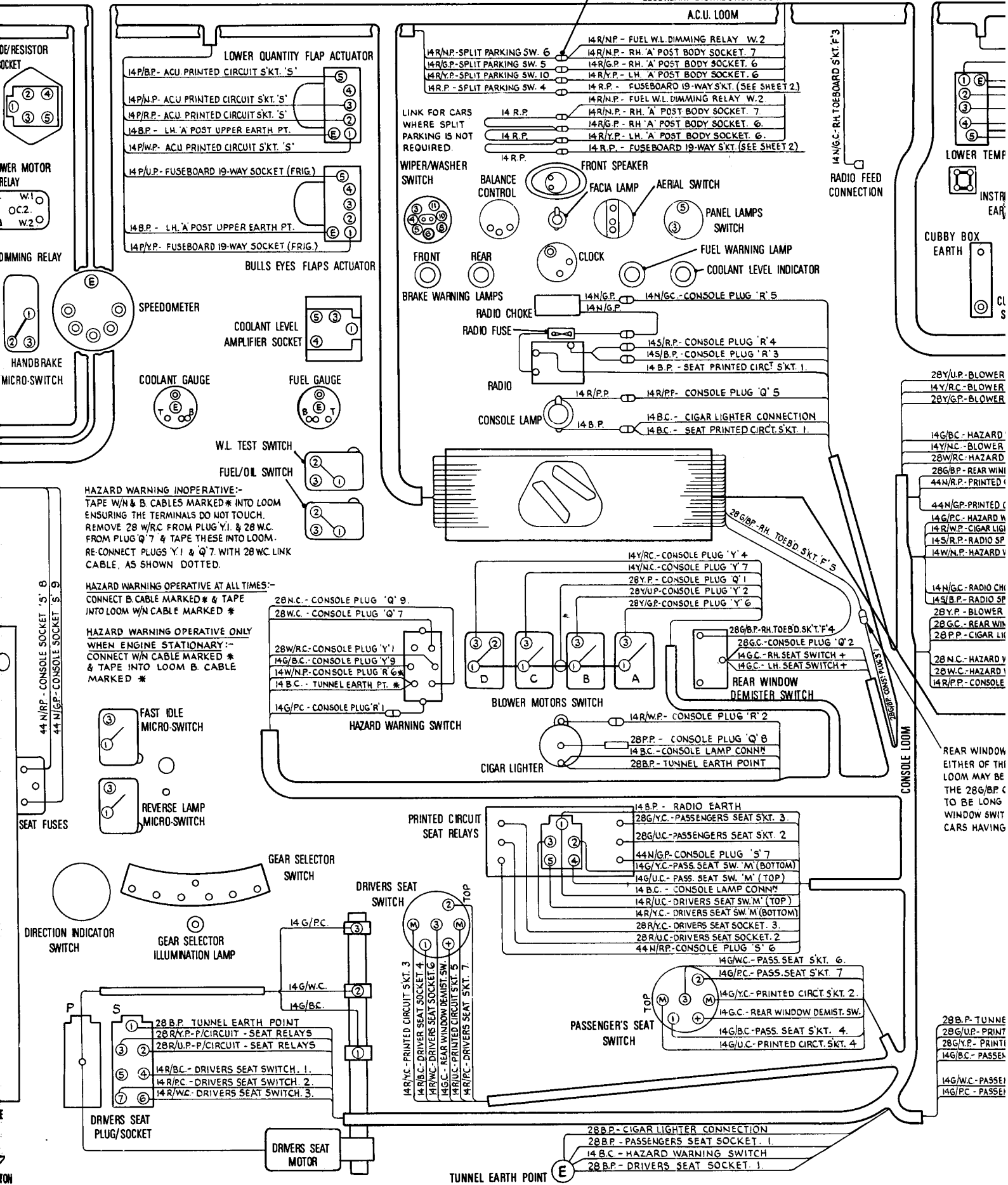

LOWER QUANTITY FLAP ACTUATOR

- 14P/B.P. - ACU PRINTED CIRCUIT S'KT. 'S'
- 14P/N.P. - ACU PRINTED CIRCUIT S'KT. 'S'
- 14P/R.P. - ACU PRINTED CIRCUIT S'KT. 'S'
- 14B.P. - LH. 'A' POST UPPER EARTH PT.
- 14P/W.P. - ACU PRINTED CIRCUIT S'KT. 'S'
- 14P/U.P. - FUSEBOARD 19-WAY SOCKET (FRIG.)
- 14B.P. - LH. 'A' POST UPPER EARTH PT.
- 14P/Y.P. - FUSEBOARD 19-WAY SOCKET (FRIG.)

LINK FOR CARS WHERE SPLIT PARKING IS NOT REQUIRED.

- 14 R.P.
- 14 R.P.
- 14 R.P.
- 14 R.P.

WIPER/WASHER SWITCH

- 14R/NP - SPLIT PARKING SW. 6
- 14R/G.P. - SPLIT PARKING SW. 5
- 14R/Y.P. - SPLIT PARKING SW. 10
- 14R.P. - SPLIT PARKING SW. 4
- 14R/NP - FUEL W.L. DIMMING RELAY W.2
- 14R/N.P. - RH. 'A' POST BODY SOCKET. 7
- 14R/G.P. - RH. 'A' POST BODY SOCKET. 6
- 14R/Y.P. - LH. 'A' POST BODY SOCKET. 6
- 14 R.P. - FUSEBOARD 19-WAY S'KT. (SEE SHEET 2)
- 14R/NP - FUEL W.L. DIMMING RELAY W.2
- 14R/N.P. - RH. 'A' POST BODY SOCKET. 7
- 14R/G.P. - RH. 'A' POST BODY SOCKET. 6
- 14R/Y.P. - LH. 'A' POST BODY SOCKET. 6
- 14 R.P. - FUSEBOARD 19-WAY S'KT. (SEE SHEET 2)

BULLS EYES FLAPS ACTUATOR

- 14N/G.P. - RH. TOEBOARD S'KT. 'F' 3

SPEEDOMETER

- 14N/G.P. - CONSOLE PLUG 'R' 5

COOLANT LEVEL AMPLIFIER SOCKET

- 14S/R.P. - CONSOLE PLUG 'R' 4
- 14S/B.P. - CONSOLE PLUG 'R' 3
- 14B.P. - SEAT PRINTED CIRCT. S'KT. 1.

COOLANT GAUGE

FUEL GAUGE

W.L. TEST SWITCH

FUEL/OIL SWITCH

FRONT SPEAKER

- 14N/G.P. - CONSOLE PLUG 'R' 5
- 14S/R.P. - CONSOLE PLUG 'R' 4
- 14S/B.P. - CONSOLE PLUG 'R' 3
- 14B.P. - SEAT PRINTED CIRCT. S'KT. 1.

RADIO

- 14R/P.P. - CONSOLE PLUG 'Q' 5
- 14B.P. - CIGAR LIGHTER CONNECTION
- 14B.C. - SEAT PRINTED CIRCT. S'KT. 1.

CONSOLE LAMP

HAZARD WARNING INOPERATIVE--
TAPE W/N & B. CABLES MARKED * INTO LOOM ENSURING THE TERMINALS DO NOT TOUCH. REMOVE 28 W/R.C. FROM PLUG 'Y' 1. & 28 W.C. FROM PLUG 'Q' 7 & TAPE THESE INTO LOOM. RE-CONNECT PLUGS 'Y' 1 & 'Q' 7. WITH 28 W.C. LINK CABLE, AS SHOWN DOTTED.

HAZARD WARNING OPERATIVE AT ALL TIMES--
CONNECT B. CABLE MARKED * & TAPE INTO LOOM W/N CABLE MARKED *

HAZARD WARNING OPERATIVE ONLY
WHEN ENGINE STATIONARY :-
CONNECT W/N CABLE MARKED * & TAPE INTO LOOM B. CABLE MARKED *

28N.C. - CONSOLE PLUG 'Q' 9.
28W.C. - CONSOLE PLUG 'Q' 7

28W/R.C. - CONSOLE PLUG 'Y' 1
14G/B.C. - CONSOLE PLUG 'Y' 9
14W/N.P. - CONSOLE PLUG 'R' 6
14B.C. - TUNNEL EARTH PT. *

14G/P.C. - CONSOLE PLUG 'R' 1

HAZARD WARNING SWITCH

BLOWER MOTORS SWITCH

- 14Y/R.C. - CONSOLE PLUG 'Y' 4
- 14Y/N.C. - CONSOLE PLUG 'Y' 7
- 28Y/P. - CONSOLE PLUG 'Q' 1
- 28Y/U.P. - CONSOLE PLUG 'Y' 2
- 28Y/G.P. - CONSOLE PLUG 'Y' 6

CIGAR LIGHTER

- 14R/W.P. - CONSOLE PLUG 'R' 2
- 28P.P. - CONSOLE PLUG 'Q' 8
- 14B.C. - CONSOLE LAMP CONN
- 28B.P. - TUNNEL EARTH POINT

REAR WINDOW DEMISTER SWITCH

- 28G/B.P. - RH. TOEBOARD S'KT. 'F' 5
- 28G/B.P. - RH. TOEBOARD S'KT. 'F' 4
- 28G.C. - CONSOLE PLUG 'Q' 2
- 14G.C. - RH. SEAT SWITCH +
- 14G.C. - LH. SEAT SWITCH +

FAST IDLE MICRO-SWITCH

REVERSE LAMP MICRO-SWITCH

GEAR SELECTOR SWITCH

DRIVERS SEAT SWITCH

- 14G/P.C.
- 14G/W.C.
- 14G/B.C.

PRINTED CIRCUIT SEAT RELAYS

- 14B.P. - RADIO EARTH
- 28G/Y.C. - PASSENGERS SEAT S'KT. 3.
- 28G/U.C. - PASSENGERS SEAT S'KT. 2.
- 44N/G.P. - CONSOLE PLUG 'S' 7
- 14G/Y.C. - PASS. SEAT SW. 'M' (BOTTOM)
- 14G/U.C. - PASS. SEAT SW. 'M' (TOP)
- 14B.C. - CONSOLE LAMP CONN
- 14R/U.C. - DRIVERS SEAT SW. 'M' (TOP)
- 14R/Y.C. - DRIVERS SEAT SW. 'M' (BOTTOM)
- 28R/Y.C. - DRIVERS SEAT SOCKET. 3.
- 28R/U.C. - DRIVERS SEAT SOCKET. 2.
- 44N/R.P. - CONSOLE PLUG 'S' 6.
- 14G/W.C. - PASS. SEAT S'KT. 6.
- 14G/P.C. - PASS. SEAT S'KT. 7.
- 14G/Y.C. - PRINTED CIRCT. S'KT. 2.
- 14G.C. - REAR WINDOW DEMIST. SW.
- 14G/B.C. - PASS. SEAT S'KT. 4.
- 14G/U.C. - PRINTED CIRCT. S'KT. 4.

PASSENGER'S SEAT SWITCH

DRIVERS SEAT PLUG/SOCKET

- 28B.P. TUNNEL EARTH POINT
- 28R/Y.P. - P/CIRCUIT - SEAT RELAYS
- 28R/U.P. - P/CIRCUIT - SEAT RELAYS
- 14R/B.C. - DRIVERS SEAT SWITCH. 1.
- 14R/P.C. - DRIVERS SEAT SWITCH. 2.
- 14R/W.C. - DRIVERS SEAT SWITCH. 3.

DRIVERS SEAT MOTOR

CONSOLE LOOM

- 28Y/U.P. - BLOWER
- 14Y/R.C. - BLOWER
- 28Y/G.P. - BLOWER
- 14G/B.C. - HAZARD
- 14Y/N.C. - BLOWER
- 28W/R.C. - HAZARD
- 28G/B.P. - REAR WIND
- 44N/R.P. - PRINTED
- 44N/G.P. - PRINTED
- 14G/P.C. - HAZARD N
- 14R/W.P. - CIGAR LIG
- 14S/R.P. - RADIO SP
- 14W/N.P. - HAZARD V
- 14N/G.C. - RADIO CH
- 14S/B.P. - RADIO SP
- 28Y.P. - BLOWER
- 28G.C. - REAR WIND
- 28P.P. - CIGAR LIG
- 28N.C. - HAZARD V
- 28W.C. - HAZARD I
- 14R/P.P. - CONSOLE
- 28B.P. - TUNNE
- 28G/U.P. - PRINT
- 28G/Y.P. - PRINTI
- 14G/B.C. - PASSE
- 14G/W.C. - PASSE
- 14G/P.C. - PASSE

REAR WINDOW EITHER OF THE LOOM MAY BE THE 28G/B.P. TO BE LONG WINDOW SWITCH CARS HAVING

TUNNEL EARTH POINT E

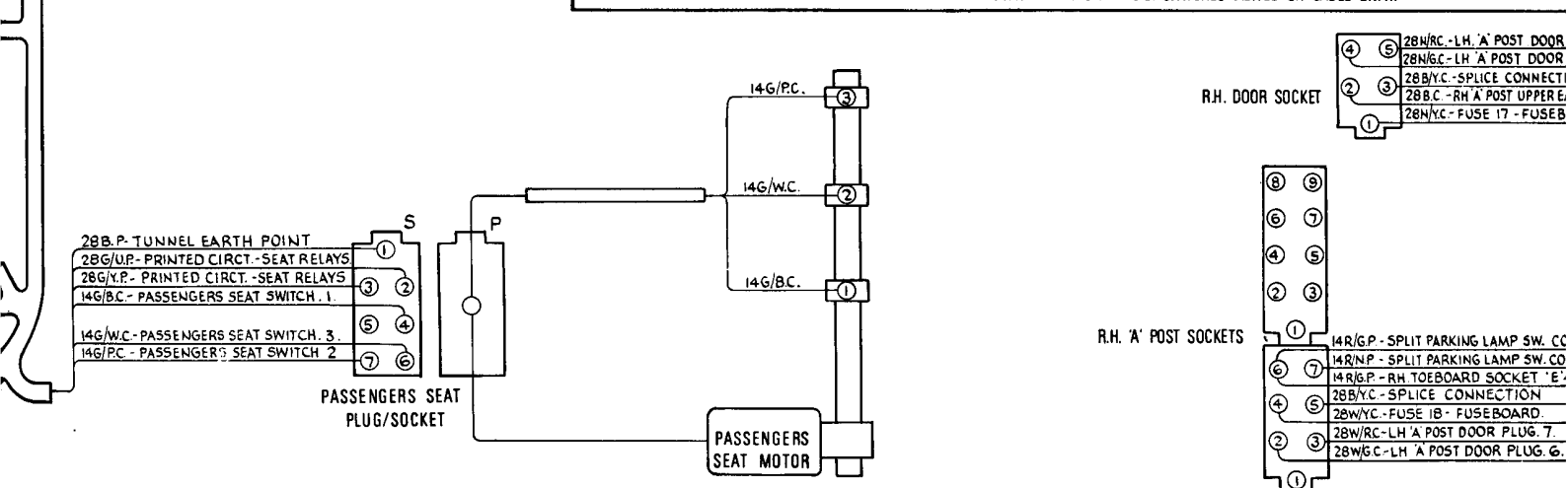
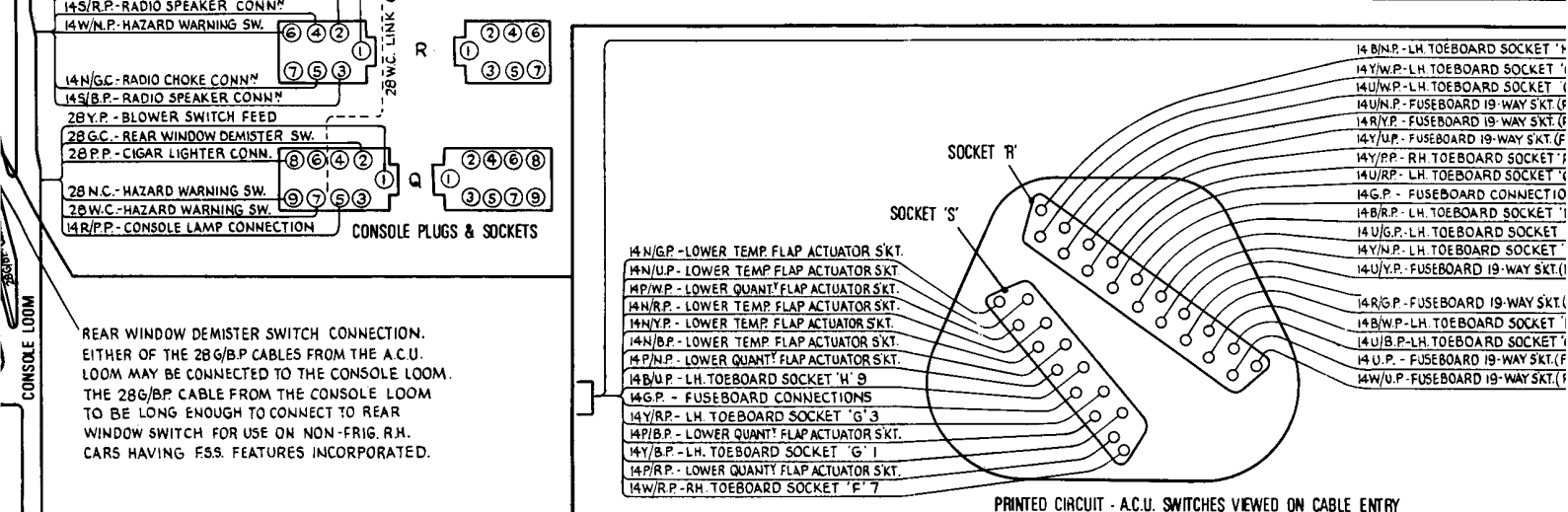
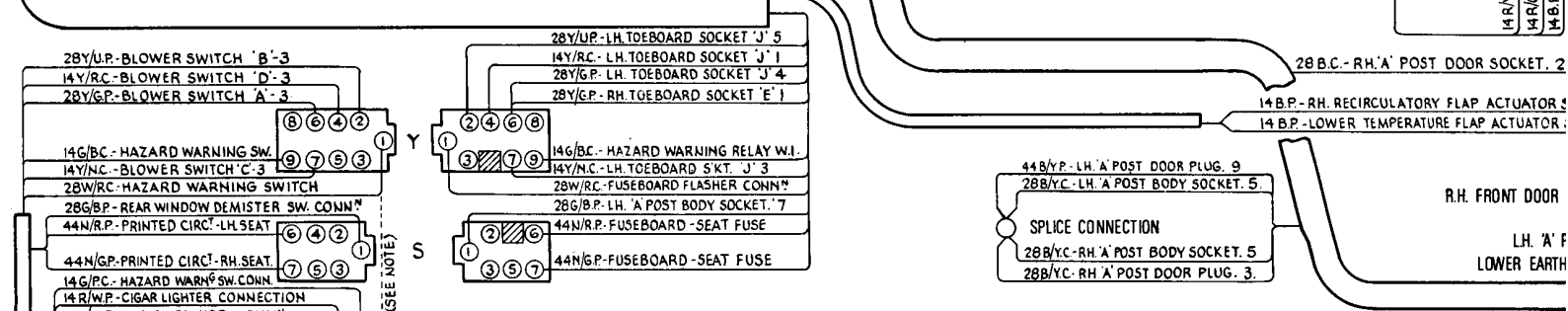
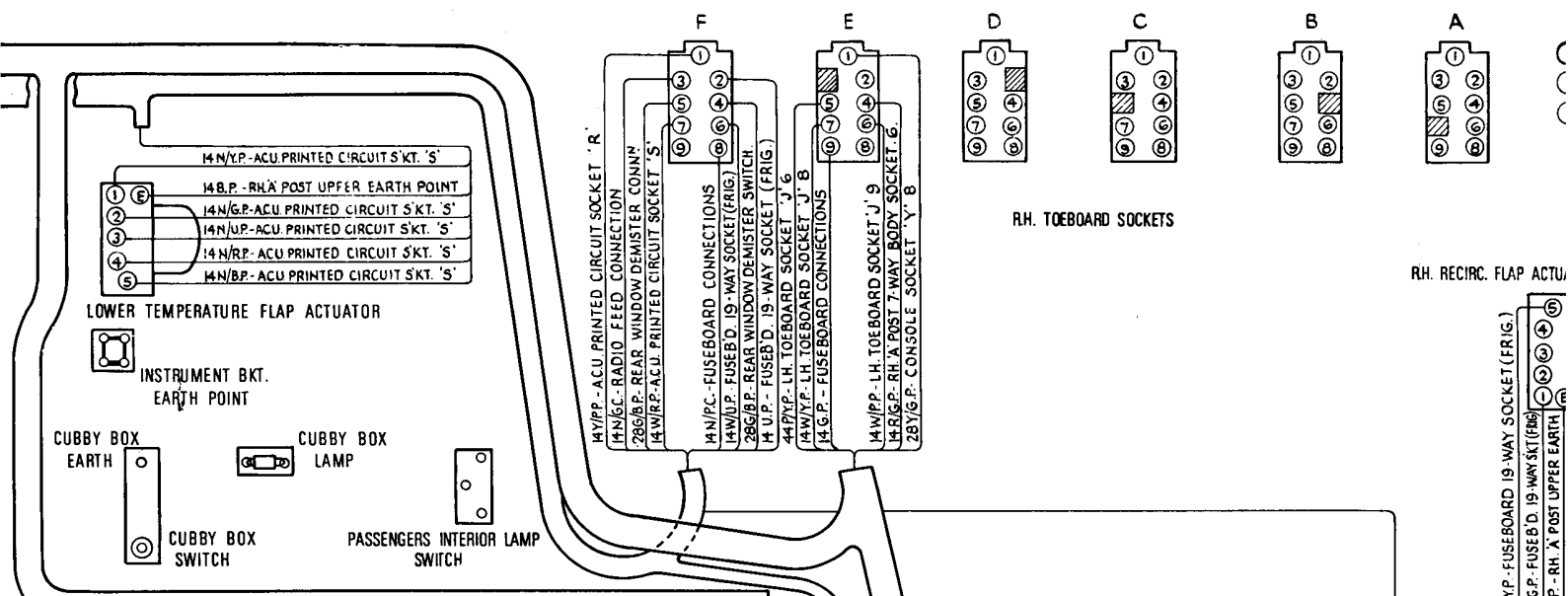

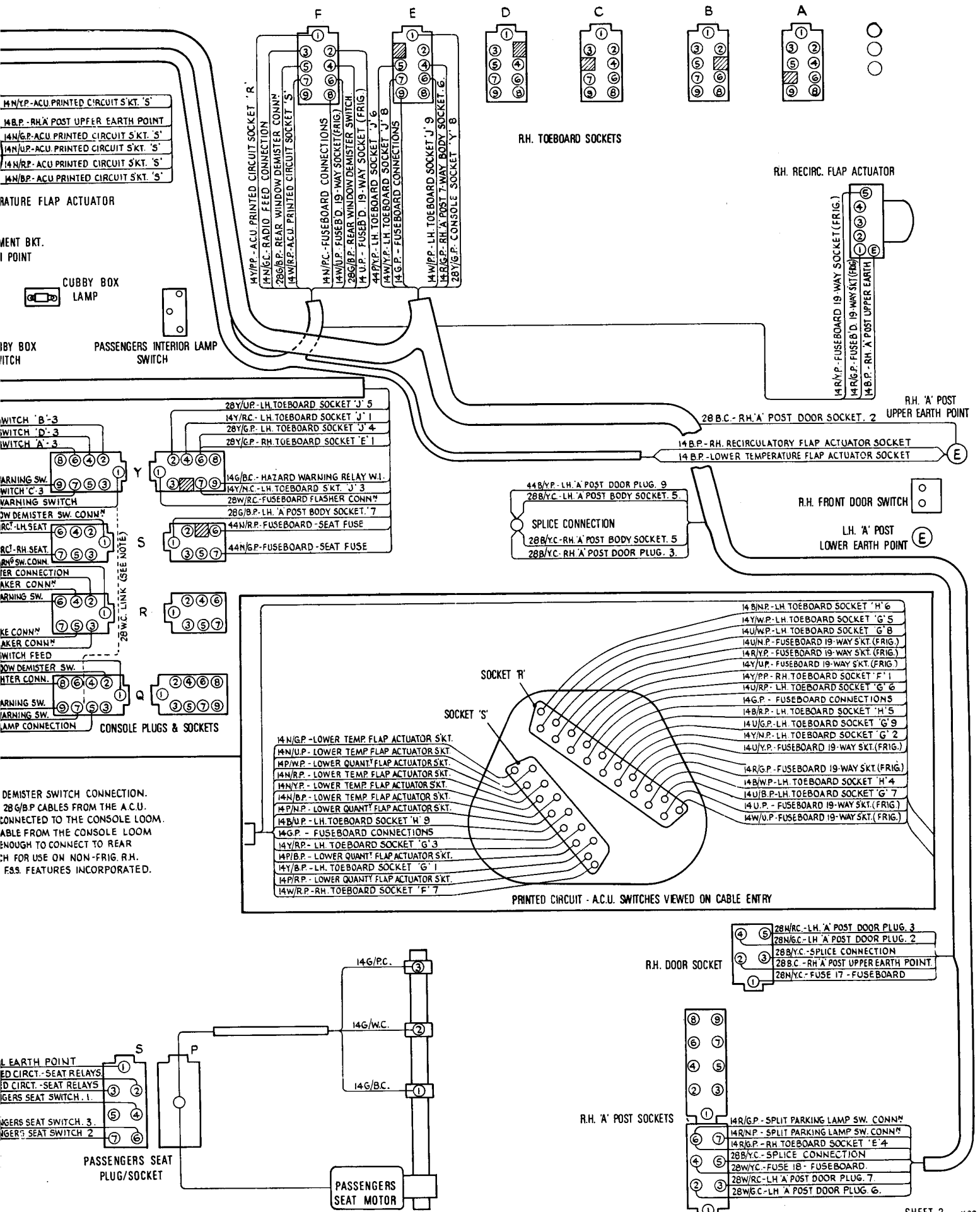

- 14N/YP-ACU PRINTED CIRCUIT S'KT. 'S'
- 14B/P-RH 'A' POST UPPER EARTH POINT
- 14N/G/P-ACU PRINTED CIRCUIT S'KT. 'S'
- 14N/UP-ACU PRINTED CIRCUIT S'KT. 'S'
- 14N/R/P-ACU PRINTED CIRCUIT S'KT. 'S'
- 14N/B/P-ACU PRINTED CIRCUIT S'KT. 'S'

TEMPERATURE FLAP ACTUATOR

INSTRUMENT BKT. POINT

CUBBY BOX LAMP

CUBBY BOX SWITCH

PASSENGERS INTERIOR LAMP SWITCH

SWITCH 'B'-3

SWITCH 'D'-3

SWITCH 'A'-3

WARNING SW.

REAR WINDOW DEMISTER SW. CONN

RC'-LH SEAT

RC'-RH SEAT

RHS SW. CONN

INTER CONNECTION

MAKER CONN

WARNING SW.

KEY CONN

MAKER CONN

SWITCH FEED

REAR WINDOW DEMISTER SW.

INTER CONN.

WARNING SW.

WARNING SW.

LAMP CONNECTION

DEMISTER SWITCH CONNECTION.
28G/B/P CABLES FROM THE A.C.U. CONNECTED TO THE CONSOLE LOOM. CABLE FROM THE CONSOLE LOOM ENOUGH TO CONNECT TO REAR SWITCH FOR USE ON NON-FRIG. R.H. F83 FEATURES INCORPORATED.

UPPER EARTH POINT

PRINTED CIRCT. SEAT RELAYS

PRINTED CIRCT. SEAT RELAYS

PASSENGERS SEAT SWITCH. 1.

PASSENGERS SEAT SWITCH. 3.

PASSENGERS SEAT SWITCH. 2.

PASSENGERS SEAT PLUG/SOCKET

PASSENGERS SEAT MOTOR

R.H. TOEBOARD SOCKETS

R.H. RECIRC. FLAP ACTUATOR

R.H. 'A' POST UPPER EARTH POINT

28 B.C. - R.H. 'A' POST DOOR SOCKET. 2

14 B.P. - R.H. RECIRCULATORY FLAP ACTUATOR SOCKET

14 B.P. - LOWER TEMPERATURE FLAP ACTUATOR SOCKET

R.H. FRONT DOOR SWITCH

L.H. 'A' POST LOWER EARTH POINT

44B/YP - LH 'A' POST DOOR PLUG. 9
28B/YC - LH 'A' POST BODY SOCKET. 5
SPLICE CONNECTION
28B/YC - RH 'A' POST BODY SOCKET. 5
28B/YC - RH 'A' POST DOOR PLUG. 3.

28Y/UP - LH TOEBOARD SOCKET 'J' 5
14Y/RC - LH TOEBOARD SOCKET 'J' 1
28Y/G/P - LH TOEBOARD SOCKET 'J' 4
28Y/G/P - RH TOEBOARD SOCKET 'E' 1

14G/BC - HAZARD WARNING RELAY W.I.
14Y/MC - LH TOEBOARD S'KT. 'J' 3
28W/R/C - FUSEBOARD FLASHER CONN
28G/B/P - LH 'A' POST BODY SOCKET. 7
44N/R/P - FUSEBOARD - SEAT FUSE
44N/G/P - FUSEBOARD - SEAT FUSE

28W/C - LINK (SEE NOTE)

14N/G/P - LOWER TEMP FLAP ACTUATOR SKT.
14N/UP - LOWER TEMP FLAP ACTUATOR SKT.
14P/W/P - LOWER QUANTY FLAP ACTUATOR SKT.
14N/R/P - LOWER TEMP FLAP ACTUATOR SKT.
14N/YP - LOWER TEMP FLAP ACTUATOR SKT.
14N/B/P - LOWER TEMP FLAP ACTUATOR SKT.
14P/N/P - LOWER QUANTY FLAP ACTUATOR SKT.
14B/U/P - LH TOEBOARD SOCKET 'H' 9
14G/P - FUSEBOARD CONNECTIONS
14Y/R/P - LH TOEBOARD SOCKET 'G' 3
14P/B/P - LOWER QUANTY FLAP ACTUATOR SKT.
14Y/B/P - LH TOEBOARD SOCKET 'G' 1
14P/R/P - LOWER QUANTY FLAP ACTUATOR SKT.
14W/R/P - RH TOEBOARD SOCKET 'F' 7

SOCKET 'R'

SOCKET 'S'

PRINTED CIRCUIT - A.C.U. SWITCHES VIEWED ON CABLE ENTRY

14B/N/P - LH TOEBOARD SOCKET 'H' 6
14Y/W/P - LH TOEBOARD SOCKET 'G' 5
14U/W/P - LH TOEBOARD SOCKET 'G' 8
14U/N/P - FUSEBOARD 19-WAY S'KT. (FRIG.)
14R/YP - FUSEBOARD 19-WAY S'KT. (FRIG.)
14Y/UP - FUSEBOARD 19-WAY S'KT. (FRIG.)
14Y/R/P - RH TOEBOARD SOCKET 'F' 1
14U/R/P - LH TOEBOARD SOCKET 'G' 6
14G/P - FUSEBOARD CONNECTIONS
14B/R/P - LH TOEBOARD SOCKET 'H' 5
14U/G/P - LH TOEBOARD SOCKET 'G' 9
14Y/N/P - LH TOEBOARD SOCKET 'G' 2
14U/Y/P - FUSEBOARD 19-WAY S'KT. (FRIG.)
14R/G/P - FUSEBOARD 19-WAY S'KT. (FRIG.)
14B/W/P - LH TOEBOARD SOCKET 'H' 4
14U/B/P - LH TOEBOARD SOCKET 'G' 7
14U/P - FUSEBOARD 19-WAY S'KT. (FRIG.)
14W/U/P - FUSEBOARD 19-WAY S'KT. (FRIG.)

28W/R/C - LH 'A' POST DOOR PLUG. 3
28N/G/C - LH 'A' POST DOOR PLUG. 2
28B/YC - SPLICE CONNECTION
28B.C. - RH 'A' POST UPPER EARTH POINT.
28N/YC - FUSE 17 - FUSEBOARD

R.H. DOOR SOCKET

R.H. 'A' POST SOCKETS

14R/G/P - SPLIT PARKING LAMP SW. CONN
14R/N/P - SPLIT PARKING LAMP SW. CONN
14R/G/P - RH TOEBOARD SOCKET 'E' 4
28B/YC - SPLICE CONNECTION
28W/YC - FUSE 18 - FUSEBOARD.
28W/R/C - LH 'A' POST DOOR PLUG. 7
28W/G.C. - LH 'A' POST DOOR PLUG. 6.

PRACTICAL WIRING DIAGRAM

SHEET 4
ELECTRICALLY OPERATED WINDOWS,
LUGGAGE COMPARTMENT AND
SIDE AND REAR EXTERIOR LIGHTING LOOMS

ROLLS-ROYCE SILVER SHADOW
AND

BENTLEY T SERIES
LEFT-HAND DRIVE CARS

(Car Serial Numbers 6000-9000)

TSD Publication 2463

© Rolls-Royce Limited (1968)

Rolls-Royce policy is one of continuous engineering improvement and the right is reserved to revise the contents of this publication without prior notice

44 B/WP - DOOR SWITCH LINK PLATE	L.H. 'A'
44 B/Y/P - MASTER SWITCH	
44 B/P - WINDOW LIFT RELAY - C1	
28 W/R.C. - WINDOW LIFT SWITCH - A	(9) (9)
28 W/G.C. - WINDOW LIFT SWITCH - A	(6) (7)
28 U/R.C. - WINDOW LIFT SWITCH - B	(4) (5)
28 U/G.C. - WINDOW LIFT SWITCH - B	(2) (3)
28 N/R.C. - WINDOW LIFT SWITCH - C	(1) (1)
28 N/G.C. - WINDOW LIFT SWITCH - C	
28 P/Y.C. - TERMINAL BLOCK	

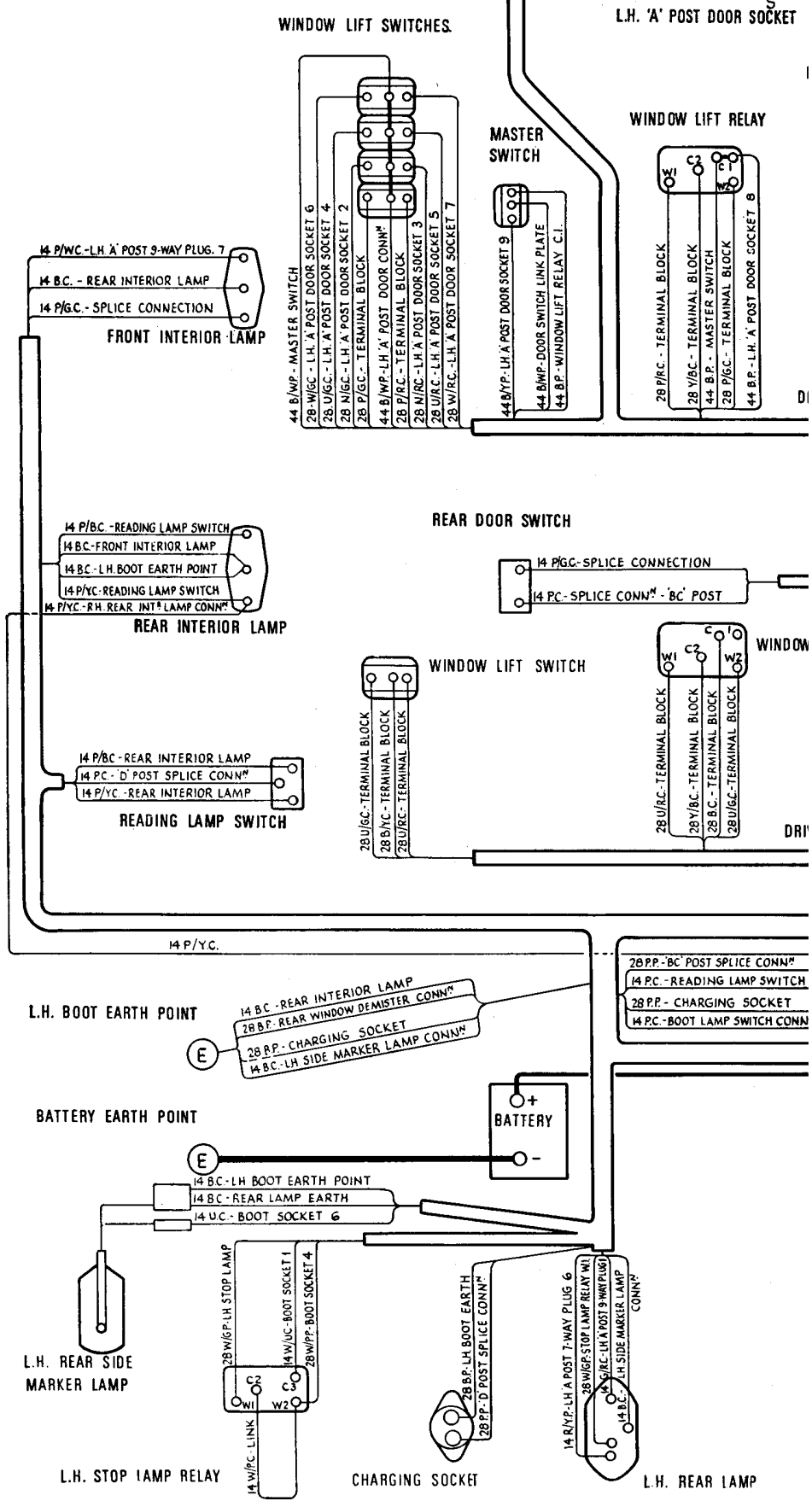

L.H. 'A' POST DOOR CONNECTION

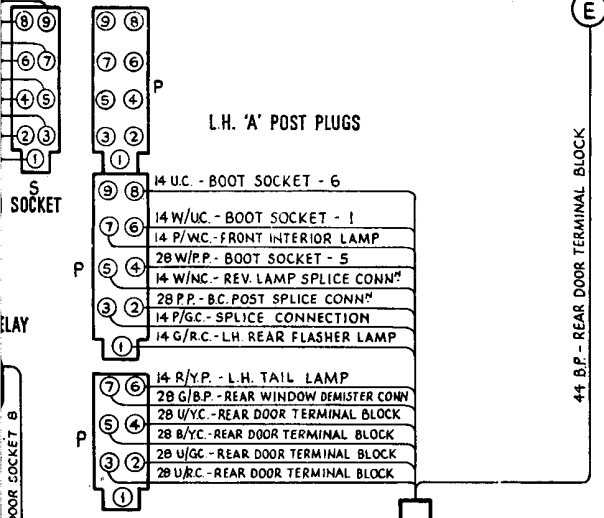

L.H. 'A' POST
LOWER EARTH POINT

DRIVER'S FRONT DOOR LOOM

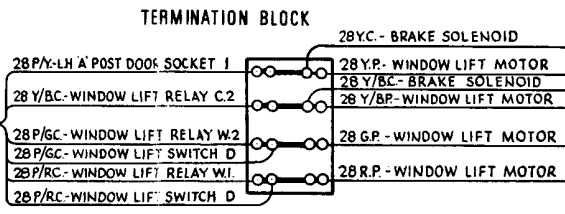

WINDOW LIFT MOTOR

BRAKE SOLENOID

SPLICE CONNECTION

WINDOW LIFT RELAY

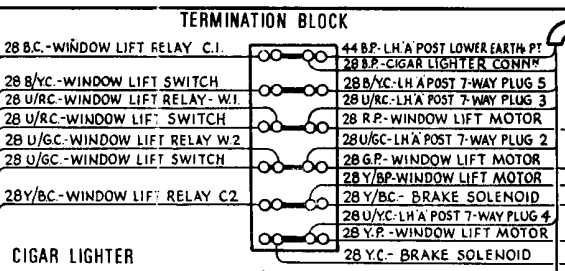

WINDOW LIFT MOTOR

BRAKE SOLENOID

BC' POST SPLICE CONNECTION

DRIVER'S REAR DOOR LOOM

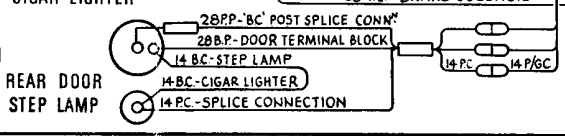

'D' POST SPLICE CONNECTION

R.H. REVERSE LAMP CONN
L.H. REVERSE LAMP CONN

REVERSE LAMP
SPLICE CONNECTION

L.H. BODY LOOM

28 G/B.P. - LH 'A' POST 6-WAY PLUG 7

REAR WINDOW DEMISTER

L.H. REVERSE LAMP

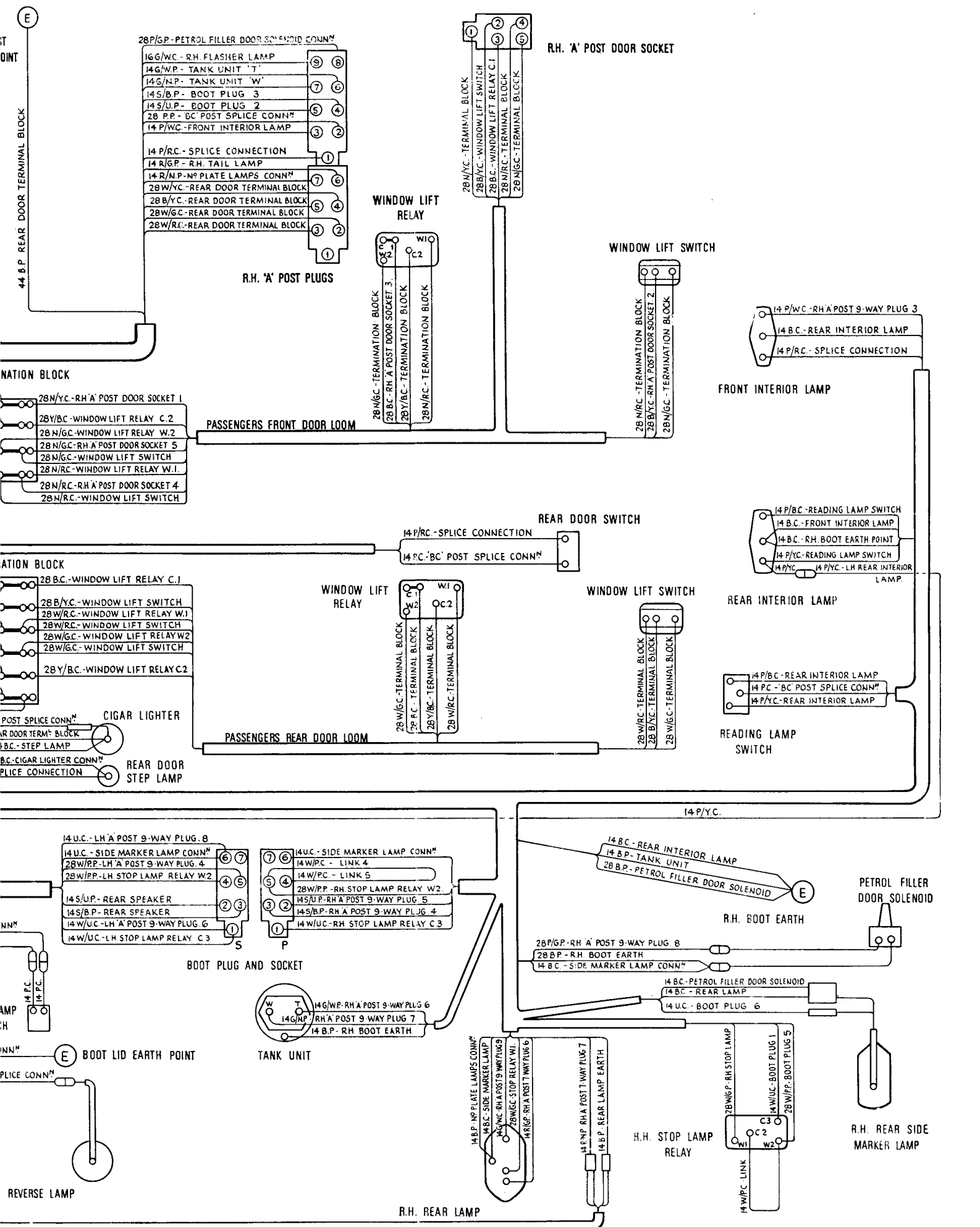

Section 6

LEFT-HAND DRIVE LONG WHEELBASE CARS WITH DIVISION, FROM SERIAL NUMBER 6598

APPLICATION	SHEET No
Theoretical	1
L.H. and R.H. Body Looms	2
Engine Looms	3
Main Distribution Looms	4

Printed in England

September 1970

T.S.D 2476

THEORETICAL WIRING DIAGRAM

SHEET 1

ROLLS-ROYCE SILVER SHADOW
AND
BENTLEY T SERIES
LEFT-HAND DRIVE LONG WHEELBASE CARS
WITH DIVISION
AFTER CAR SERIAL NUMBER LRX 6598

TSD Publications 2554

© Rolls-Royce Limited 1969

Rolls-Royce policy is one of continuous engineering improvement and the right is reserved to revise the contents of this publication without prior notice.

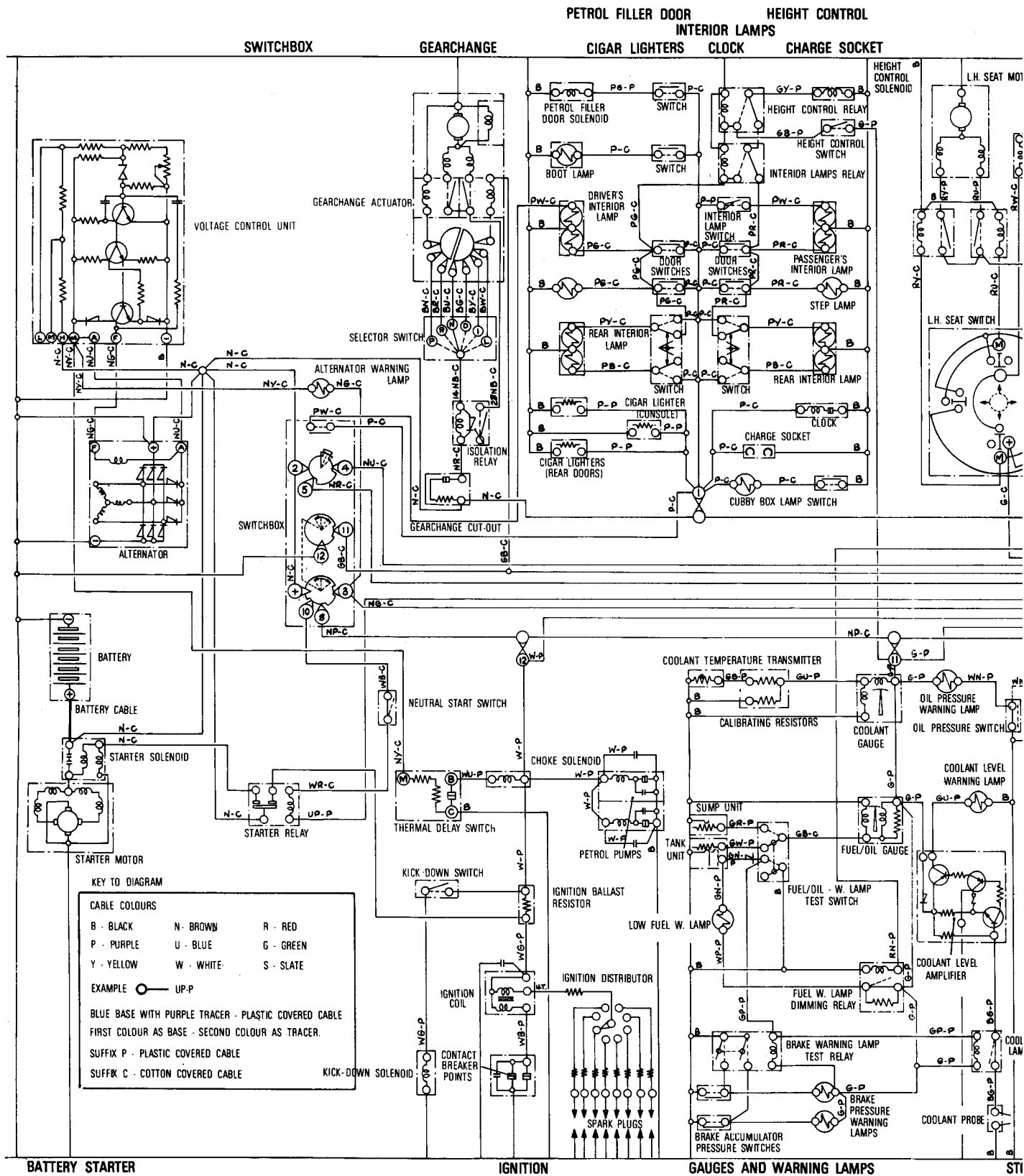

BATTERY STARTER

IGNITION

GAUGES AND WARNING LAMPS

STI

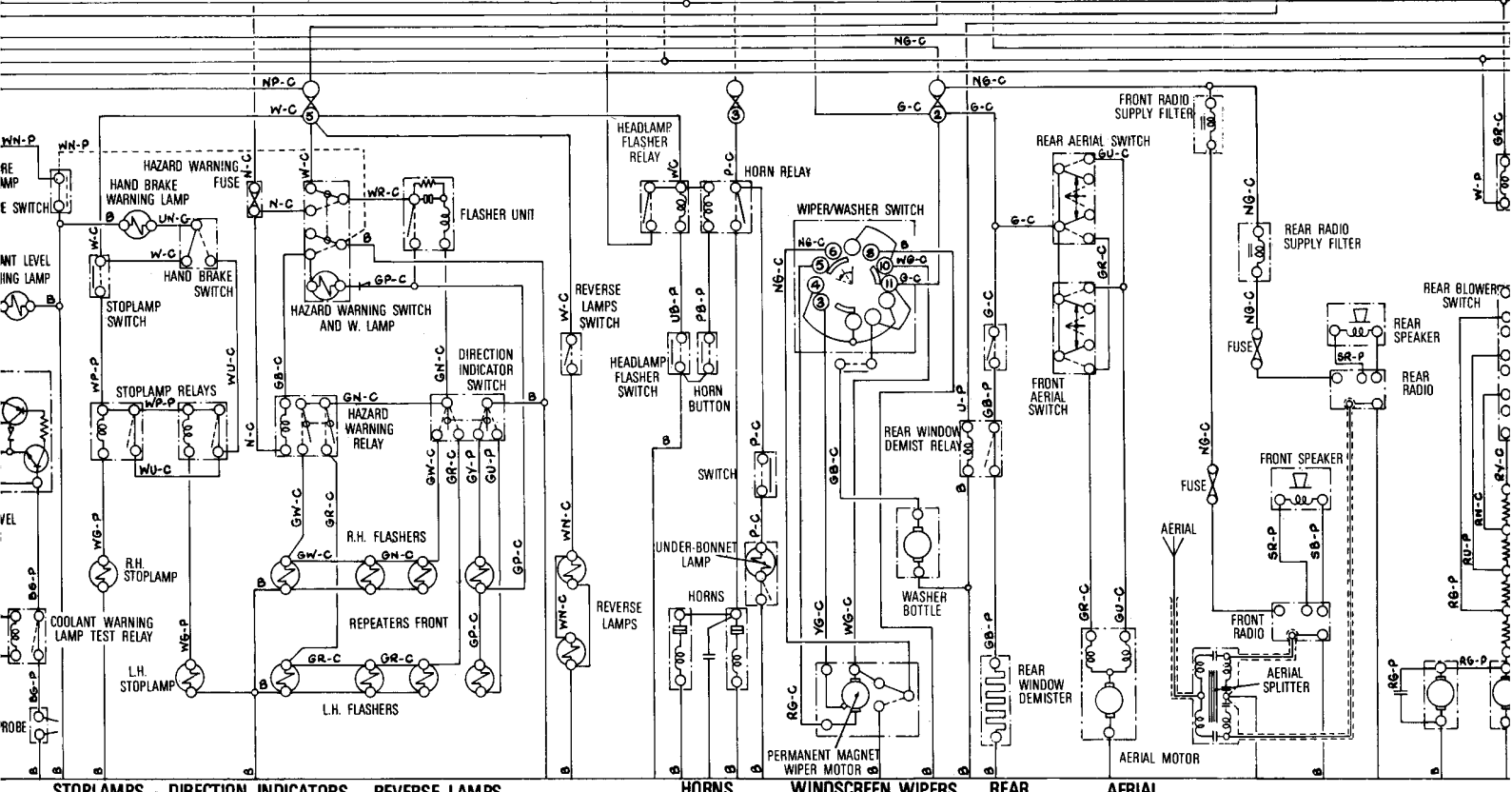
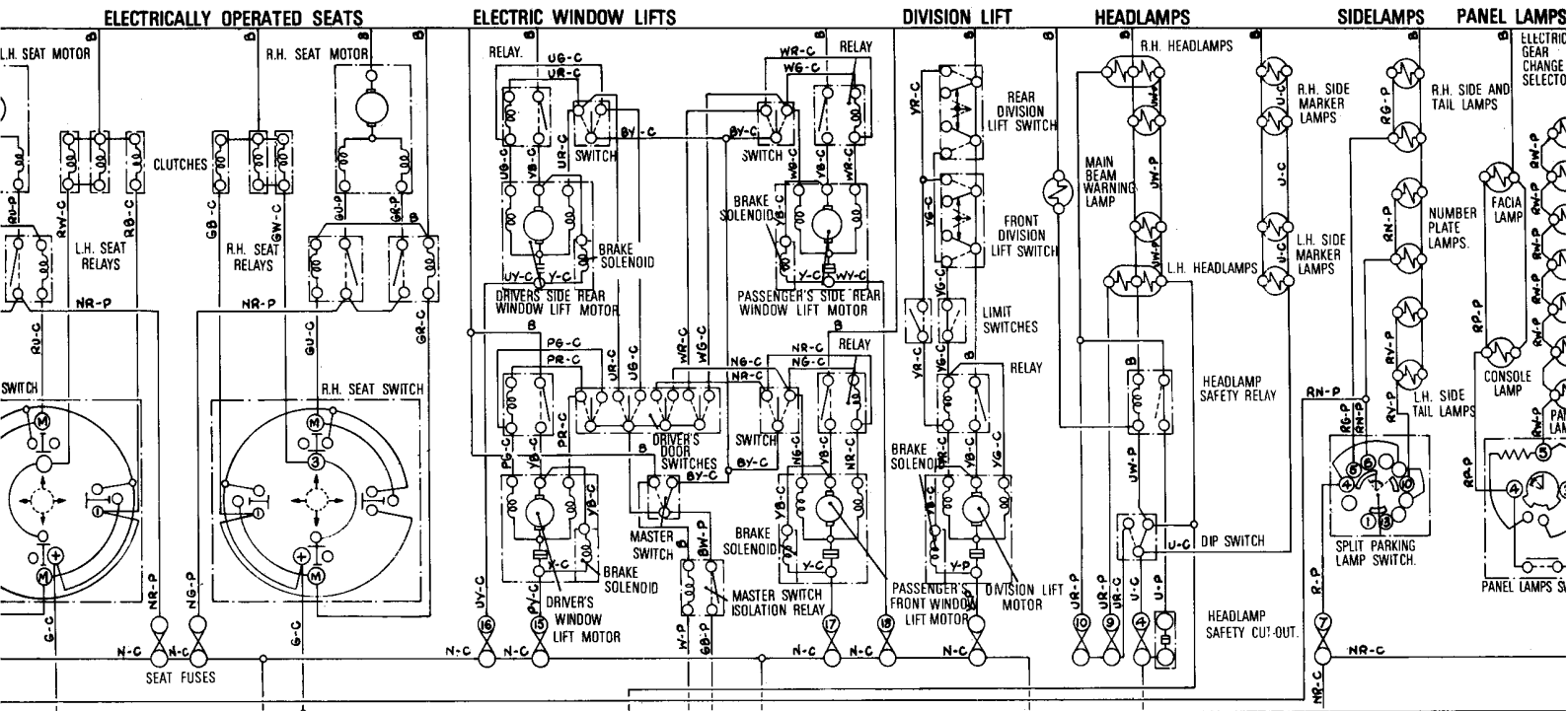

STOPLAMPS - DIRECTION INDICATORS - REVERSE LAMPS

HORNS

WINDSCREEN WIPERS

REAR WINDOW DEMISTER

AERIAL

PRACTICAL WIRING DIAGRAM

SHEET 2

L.H. & R.H. BODY LOOMS

ROLLS-ROYCE SILVER SHADOW

AND

BENTLEY T SERIES

LEFT-HAND DRIVE LONG WHEELBASE CARS

WITH DIVISION

AFTER CAR SERIAL NUMBER LRX 6598

TSD Publications 2554

© Rolls-Royce Limited 1969

Rolls-Royce policy is one of continuous engineering improvement and the right is reserved to revise the contents of this publication without prior notice.

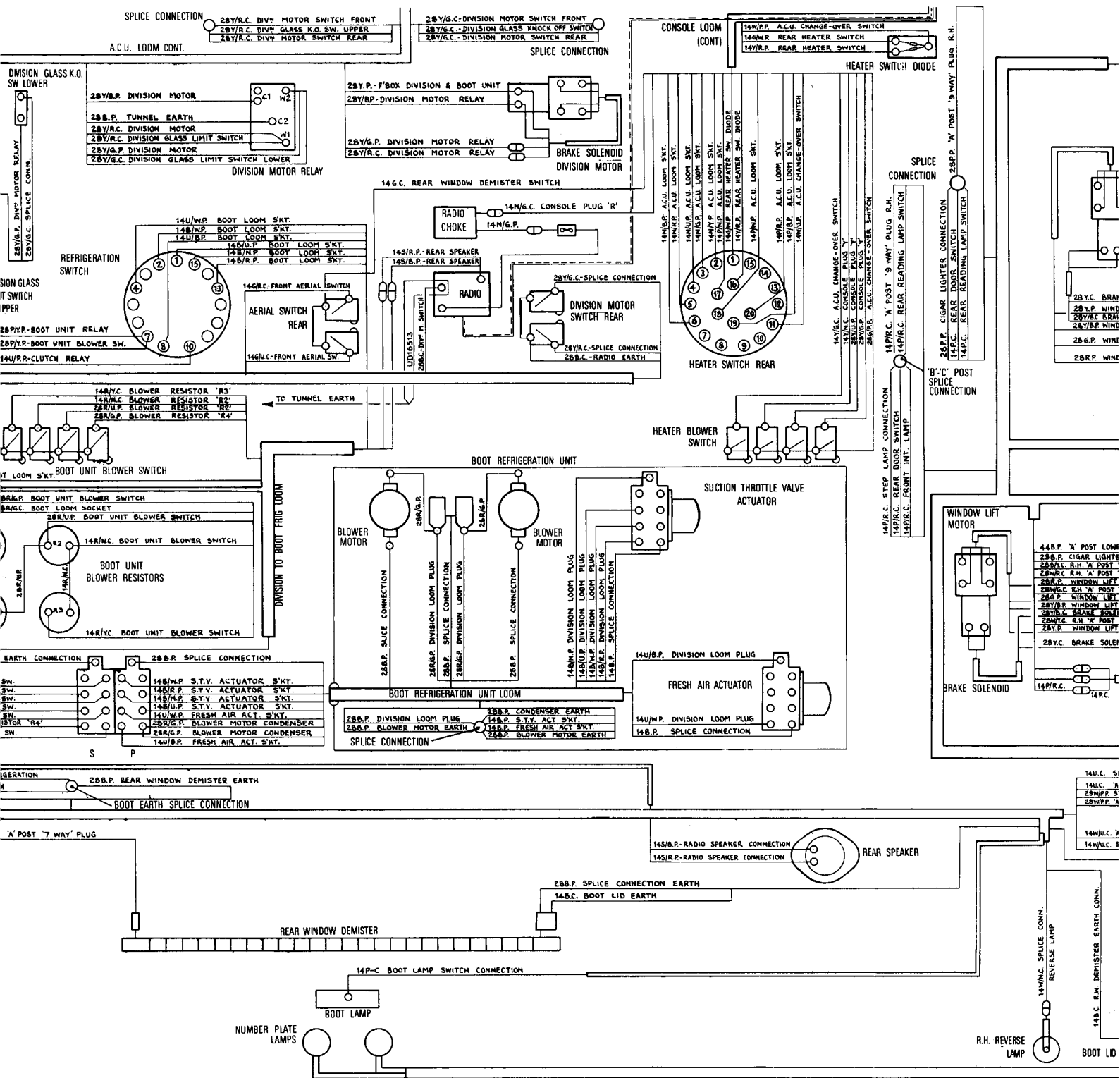

14U.C. 5
14U.C. 6
14U.C. 7
14U.C. 8
14U.C. 9
14U.C. 10
14U.C. 11
14U.C. 12
14U.C. 13
14U.C. 14
14U.C. 15
14U.C. 16
14U.C. 17
14U.C. 18
14U.C. 19
14U.C. 20
14U.C. 21
14U.C. 22
14U.C. 23
14U.C. 24
14U.C. 25
14U.C. 26
14U.C. 27
14U.C. 28
14U.C. 29
14U.C. 30
14U.C. 31
14U.C. 32
14U.C. 33
14U.C. 34
14U.C. 35
14U.C. 36
14U.C. 37
14U.C. 38
14U.C. 39
14U.C. 40
14U.C. 41
14U.C. 42
14U.C. 43
14U.C. 44
14U.C. 45
14U.C. 46
14U.C. 47
14U.C. 48
14U.C. 49
14U.C. 50
14U.C. 51
14U.C. 52
14U.C. 53
14U.C. 54
14U.C. 55
14U.C. 56
14U.C. 57
14U.C. 58
14U.C. 59
14U.C. 60
14U.C. 61
14U.C. 62
14U.C. 63
14U.C. 64
14U.C. 65
14U.C. 66
14U.C. 67
14U.C. 68
14U.C. 69
14U.C. 70
14U.C. 71
14U.C. 72
14U.C. 73
14U.C. 74
14U.C. 75
14U.C. 76
14U.C. 77
14U.C. 78
14U.C. 79
14U.C. 80
14U.C. 81
14U.C. 82
14U.C. 83
14U.C. 84
14U.C. 85
14U.C. 86
14U.C. 87
14U.C. 88
14U.C. 89
14U.C. 90
14U.C. 91
14U.C. 92
14U.C. 93
14U.C. 94
14U.C. 95
14U.C. 96
14U.C. 97
14U.C. 98
14U.C. 99
14U.C. 100

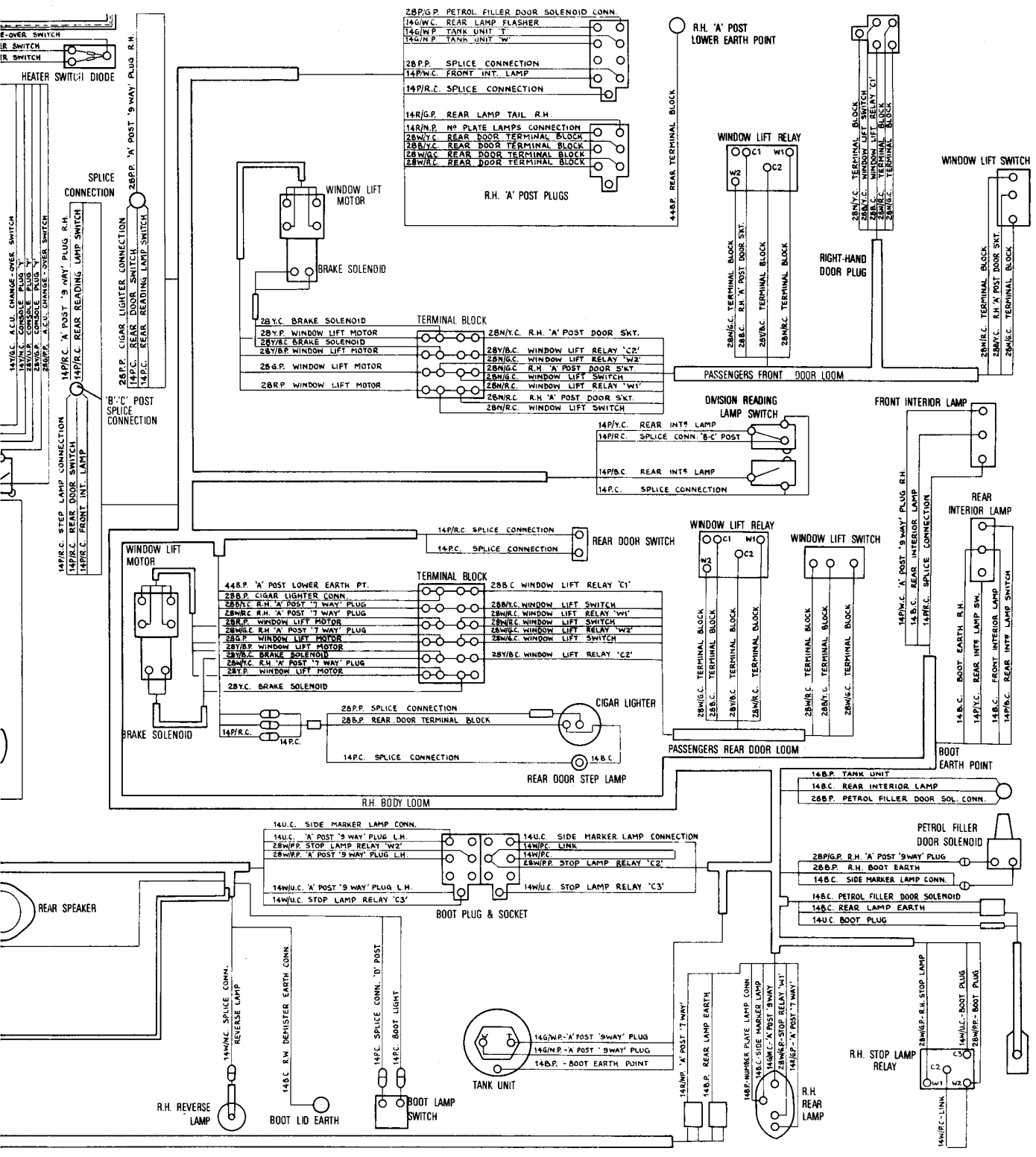

PRACTICAL WIRING DIAGRAM

SHEET 3

ENGINE LOOMS

ROLLS-ROYCE SILVER SHADOW

AND

BENTLEY T SERIES

LEFT-HAND DRIVE LONG WHEELBASE CARS

WITH DIVISION

AFTER CAR SERIAL NUMBER LRX 6598

TSD Publications 2554

© Rolls-Royce Limited 1969

Rolls-Royce policy is one of continuous engineering improvement and the right is reserved to revise the contents of this publication without prior notice.

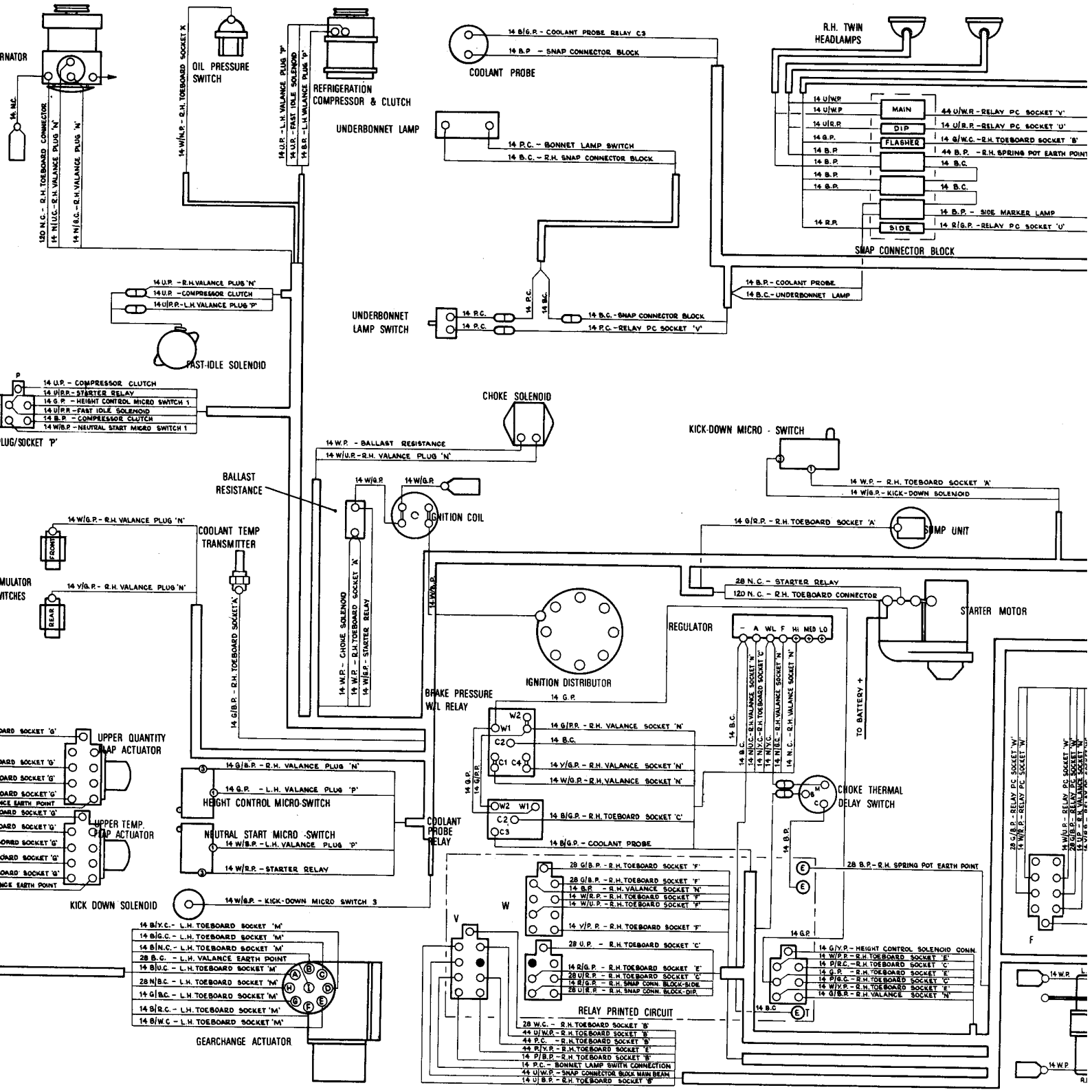

- 14 B/Y.C. - L.H. TOEBOARD SOCKET M
- 14 B/G.C. - L.H. TOEBOARD SOCKET M
- 14 B/N.C. - L.H. TOEBOARD SOCKET M
- 28 B.C. - L.H. VALANCE EARTH POINT
- 14 B/J.C. - L.H. TOEBOARD SOCKET M
- 28 N/B.C. - L.H. TOEBOARD SOCKET M
- 14 G/B.C. - L.H. TOEBOARD SOCKET M
- 14 B/R.C. - L.H. TOEBOARD SOCKET M
- 14 B/W.C. - L.H. TOEBOARD SOCKET M

- RELAY PRINTED CIRCUIT**
- 28 W.C. - R.H. TOEBOARD SOCKET B
 - 44 U/W.P. - R.H. TOEBOARD SOCKET B
 - 44 P.C. - R.H. TOEBOARD SOCKET B
 - 44 R/V.B. - R.H. TOEBOARD SOCKET B
 - 28 U/R.P. - R.H. TOEBOARD SOCKET B
 - 14 R/G.P. - R.H. TOEBOARD SOCKET B
 - 14 R/B.P. - R.H. TOEBOARD SOCKET B
 - 14 P.C. - BONNET LAMP SWITCH CONNECTION
 - 44 U/W.P. - SNAP CONNECTOR BLOCK MAIN BEAM
 - 14 U/B.P. - R.H. TOEBOARD SOCKET B

- 14 G/P.P. - HEIGHT CONTROL SOLENOID CONN
- 14 P/B.C. - R.H. TOEBOARD SOCKET C
- 14 G.R. - R.H. TOEBOARD SOCKET C
- 14 P/B.C. - R.H. TOEBOARD SOCKET C
- 14 W/V.P. - R.H. TOEBOARD SOCKET F
- 14 G/B.R. - R.H. VALANCE SOCKET N

- 28 G/B.P. - R.H. TOEBOARD SOCKET F
- 28 G/R.P. - R.H. TOEBOARD SOCKET F
- 14 B.P. - R.H. VALANCE SOCKET N
- 14 W/R.P. - R.H. TOEBOARD SOCKET F
- 14 W/U.P. - R.H. TOEBOARD SOCKET F
- 14 V/P.P. - R.H. TOEBOARD SOCKET F
- 28 U.R. - R.H. TOEBOARD SOCKET C

- 14 G/R.R. - R.H. VALANCE SOCKET N
- 14 B.C.
- 14 V/G.P. - R.H. VALANCE SOCKET N
- 14 W/G.R. - R.H. VALANCE SOCKET N
- 14 B/G.R. - R.H. TOEBOARD SOCKET C
- 14 B/G.P. - COOLANT PROBE

- 14 B.C.
- 14 N/C. - R.H. TOEBOARD SOCKET V
- 14 N/C. - R.H. TOEBOARD SOCKET V
- 12 N/B.C. - R.H. VALANCE SOCKET N
- 14 N.C. - R.H. VALANCE SOCKET N

- 14 W.R. - R.H. TOEBOARD SOCKET M
- 14 W/R. - KICK-DOWN SOLENOID

- 14 U/W.P.
- 14 U/W.P.
- 14 U/R.P.
- 14 G.P.
- 14 B.P.
- 14 B.P.
- 14 B.P.
- 14 R.P.

- 44 U/W.R. - RELAY PC SOCKET V
- 14 U/R.R. - RELAY PC SOCKET U
- 14 G/W.C. - R.H. TOEBOARD SOCKET B
- 44 B.P. - R.H. SPRING POT EARTH POINT
- 14 B.C.
- 14 B.C.
- 14 B.P. - SIDE MARKER LAMP
- 14 R/G.P. - RELAY PC SOCKET U

PRACTICAL WIRING DIAGRAM

SHEET 4

MAIN DISTRIBUTION LOOMS

ROLLS-ROYCE SILVER SHADOW

AND

BENTLEY T SERIES

LEFT-HAND DRIVE LONG WHEELBASE CARS

WITH DIVISION

AFTER CAR SERIAL NUMBER LRX 6598

TSD Publications 2554

© Rolls-Royce Limited 1969

Rolls-Royce policy is one of continuous engineering improvement and the right is reserved to revise the contents of this publication without prior notice.

SECONDARY DISTRIBUTION LOOM

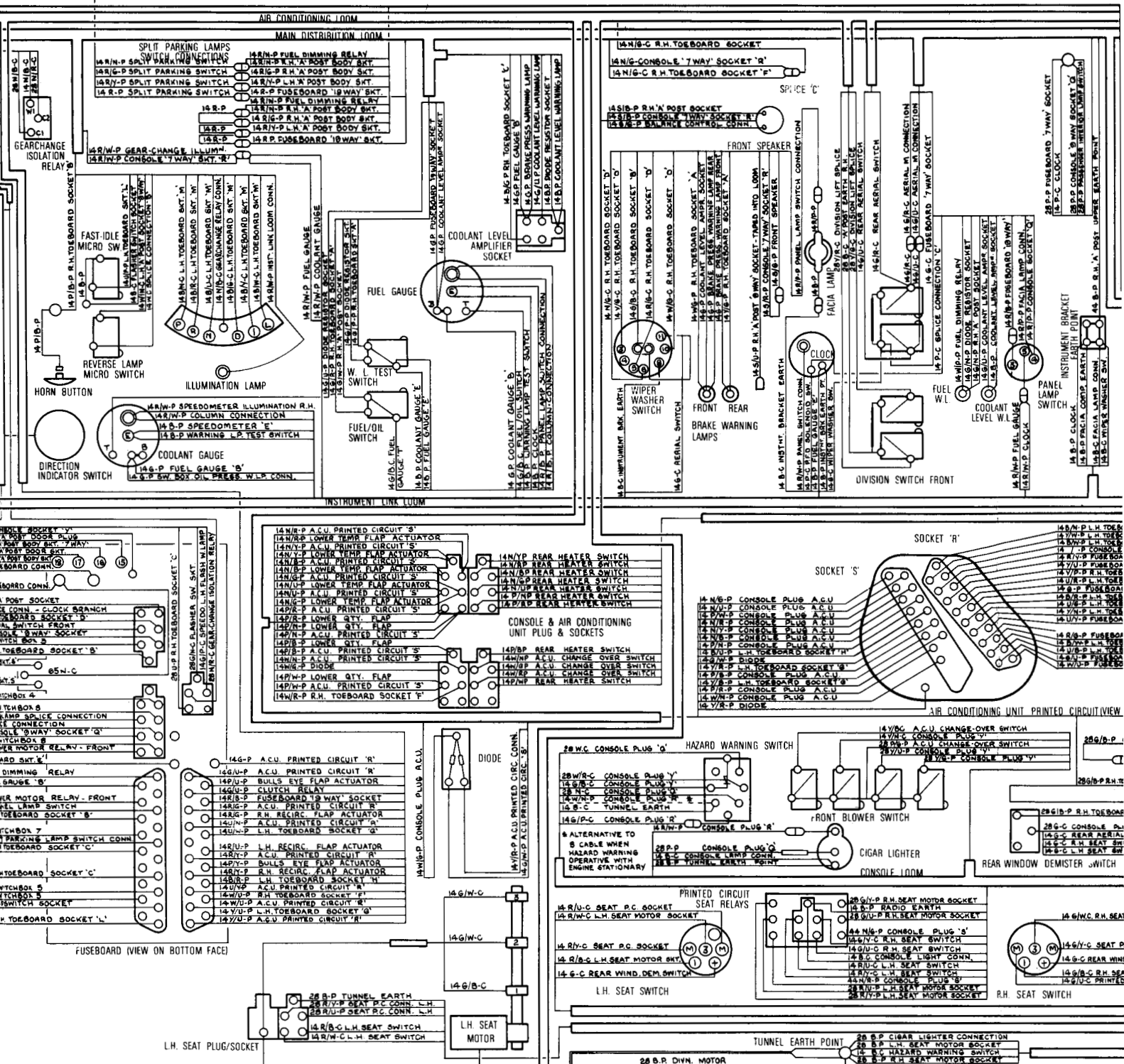

L.H. SEAT PLUG/SOCKET

L.H. SEAT MOTOR

L.H. SEAT SWITCH

R.H. SEAT SWITCH

14 G/W.C. SEAT P

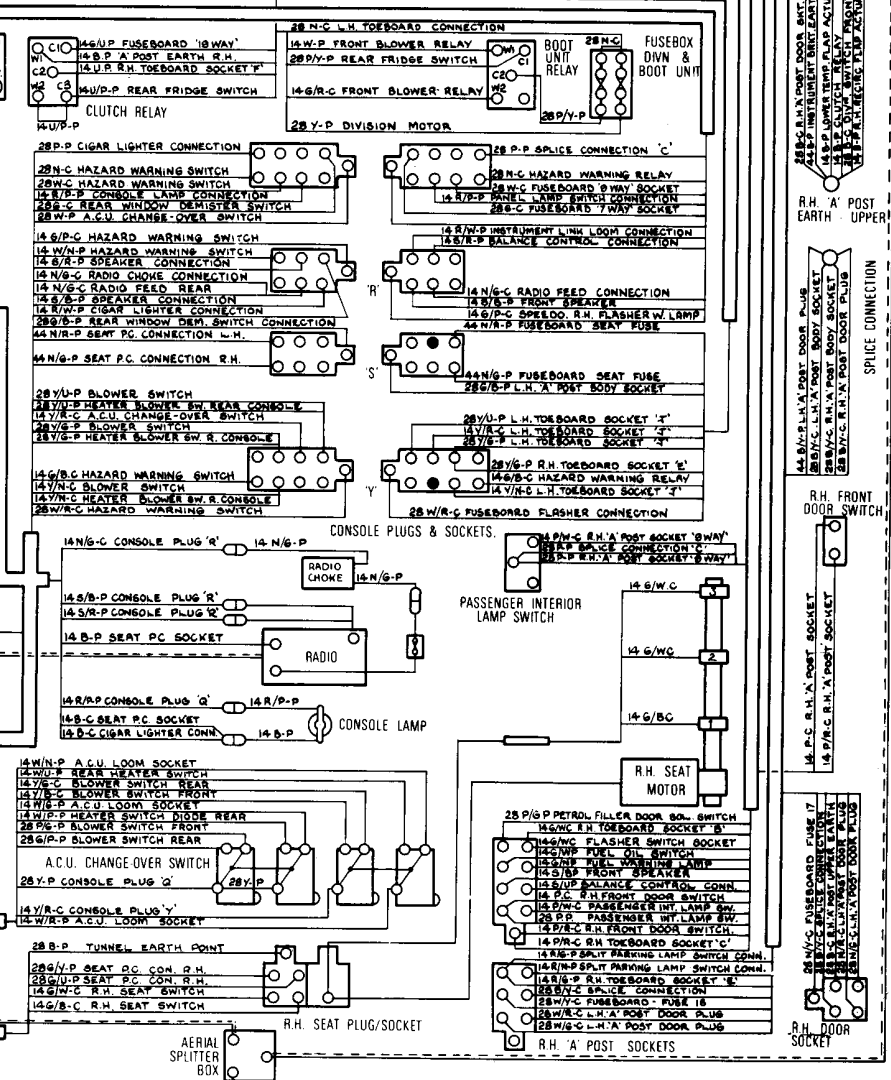
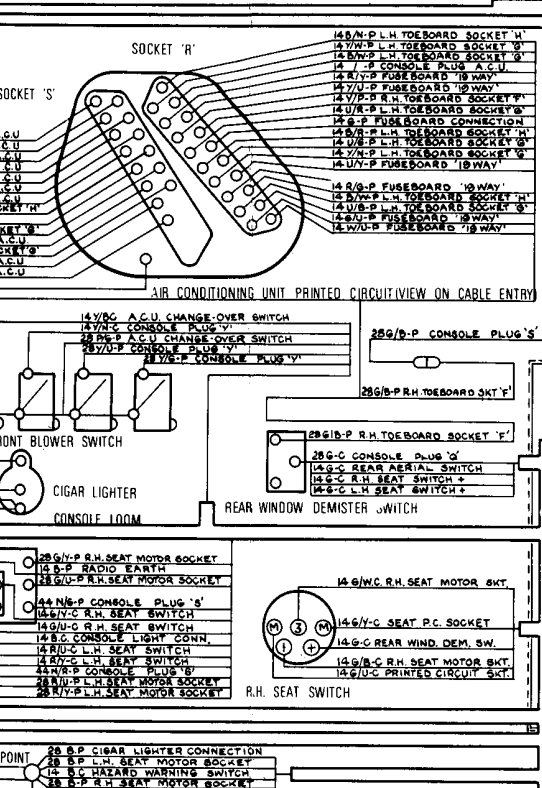
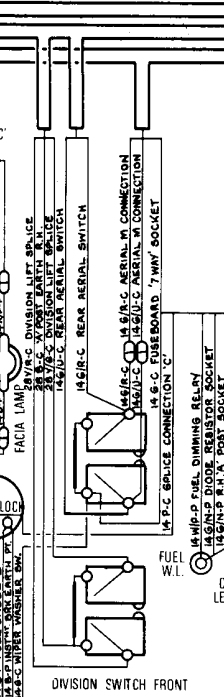
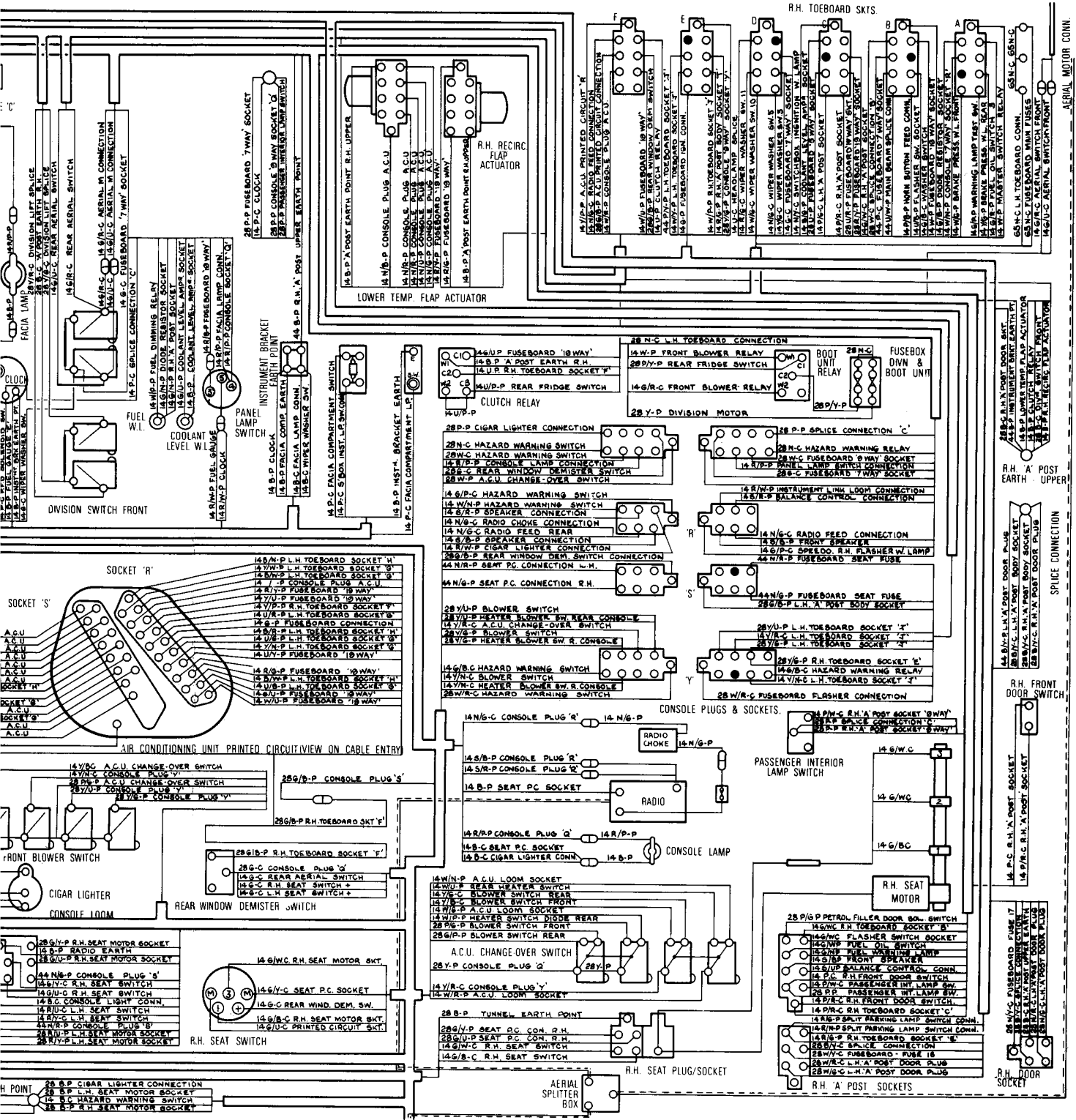

Section 7

LEFT-HAND DRIVE CARS PRIOR TO SERIAL NUMBER 6000

APPLICATION	SHEET No
Engine and Instruments	1
Electrically Operated Seats	2
Lighting	3
Electrically Operated Windows	4
Starter and Ignition	5
Air Conditioning Unit (A.C.U.)	6
Interior Lighting	7
Gear Range Selector	8
Radio Receiver and Speakers	9
Direction Indicators and Handbrake Warning Lamp	10

PRACTICAL WIRING DIAGRAM

SHEET 1

ENGINE AND INSTRUMENTS

ROLLS-ROYCE SILVER SHADOW AND BENTLEY T SERIES LEFT-HAND DRIVE CARS PRIOR TO CAR SERIAL NUMBER SRX 6000

TSD Publication 2571

© Rolls-Royce Limited 1969

Rolls-Royce policy is one of continuous engineering improvement and the right is reserved to revise the contents of this publication without prior notice.

KEY TO DIAGRAM

CABLE COLOURS

- | | | |
|------------|-----------|-----------|
| B - BLACK | N - BROWN | R - RED |
| P - PURPLE | U - BLUE | G - GREEN |
| Y - YELLOW | W - WHITE | S - SLATE |

EXAMPLE  UP-P

BLUE BASE WITH PURPLE TRACER PLASTIC COVERED
 FIRST COLOUR AS BASE SECOND COLOUR AS TRACER
 SUFFIX P - PLASTIC COVERED CABLE
 SUFFIX C - COTTON COVERED CABLE

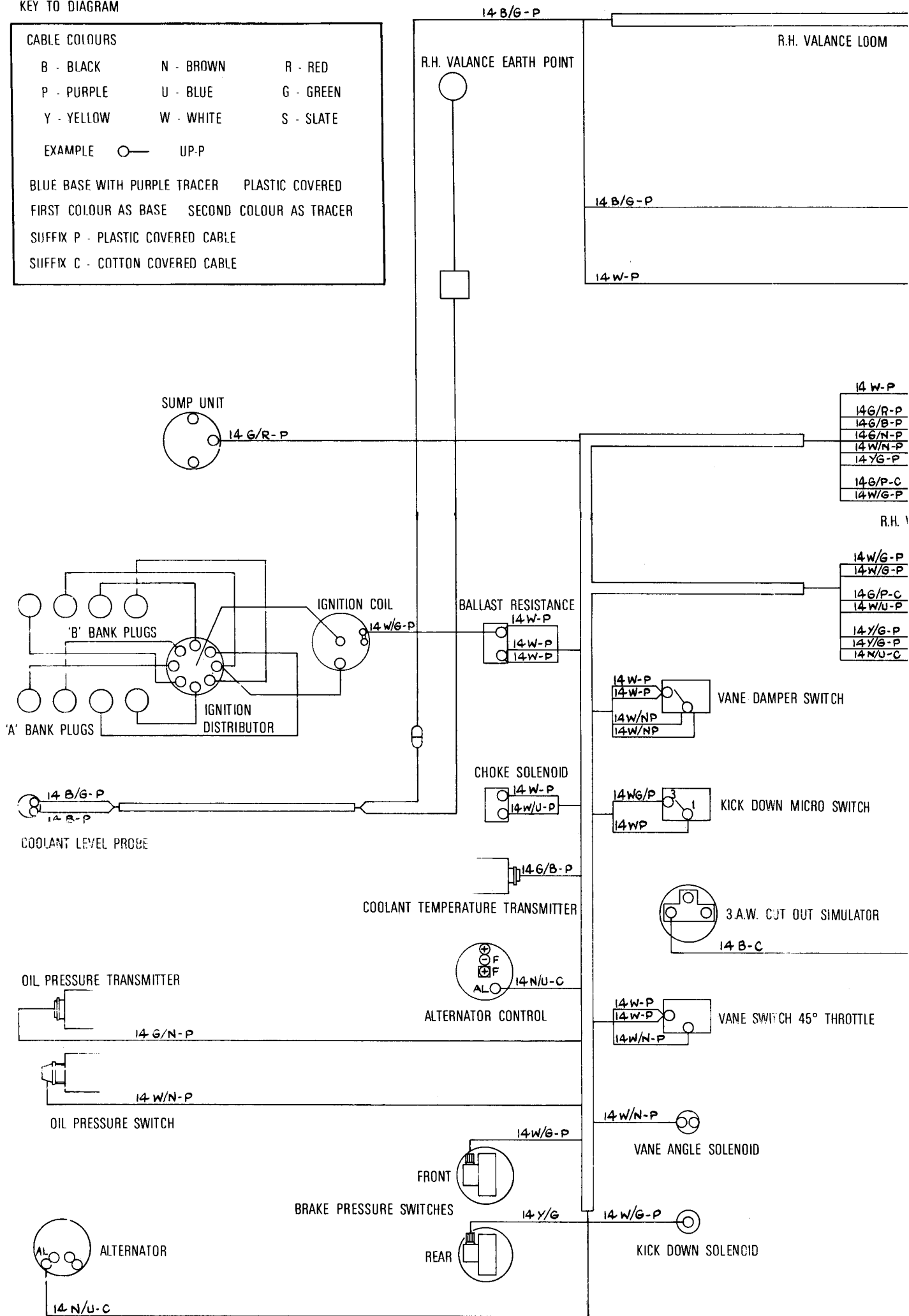

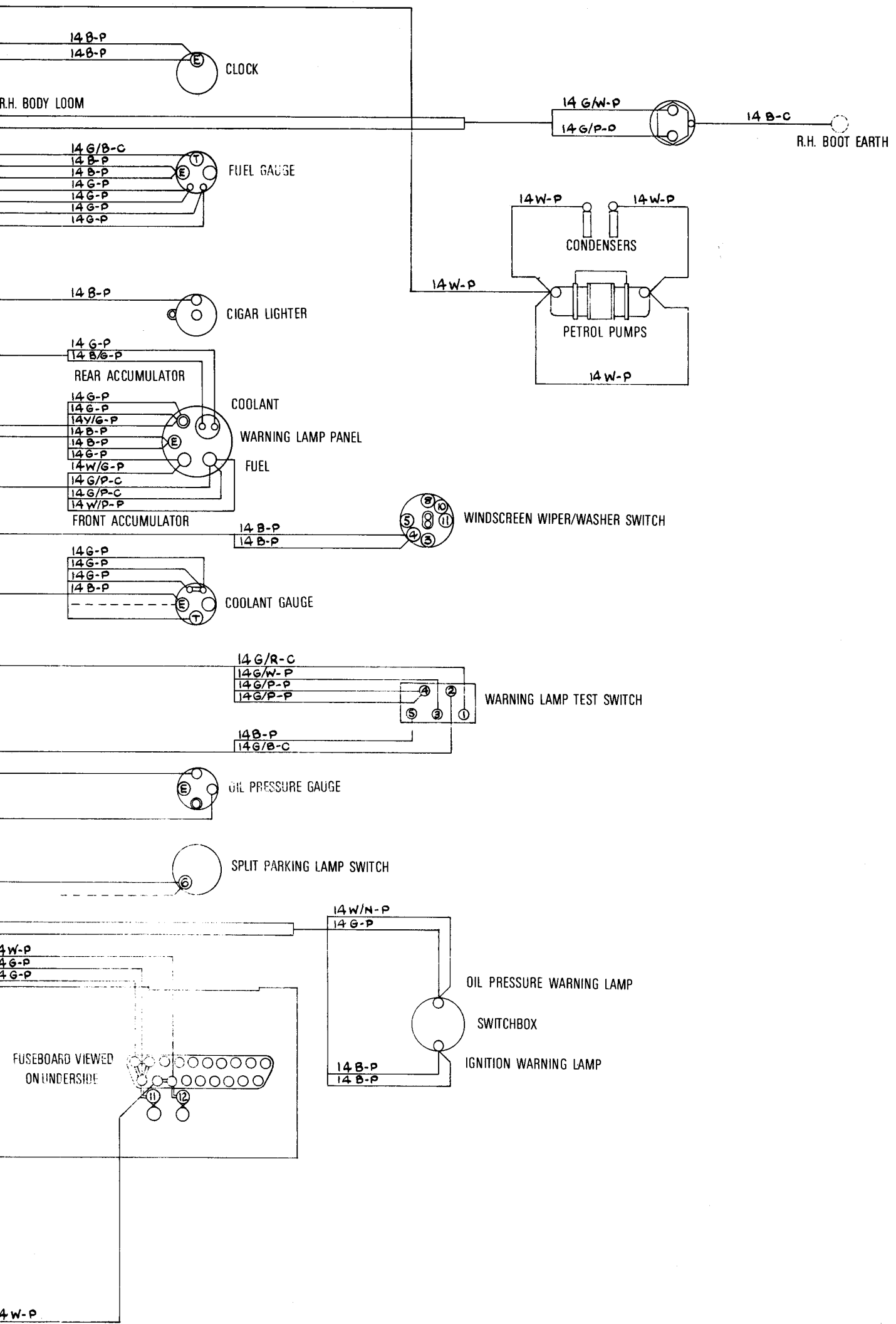

PRACTICAL WIRING DIAGRAM

SHEET 2

ELECTRICALLY OPERATED FRONT SEATS

ROLLS-ROYCE SILVER SHADOW

AND

BENTLEY T SERIES

LEFT-HAND DRIVE CARS

PRIOR TO CAR SERIAL NUMBER SRX 6000

TSD Publication 2571

© Rolls-Royce Limited 1969

Rolls-Royce policy is one of continuous engineering improvement and the right is reserved to revise the contents of this publication without prior notice.

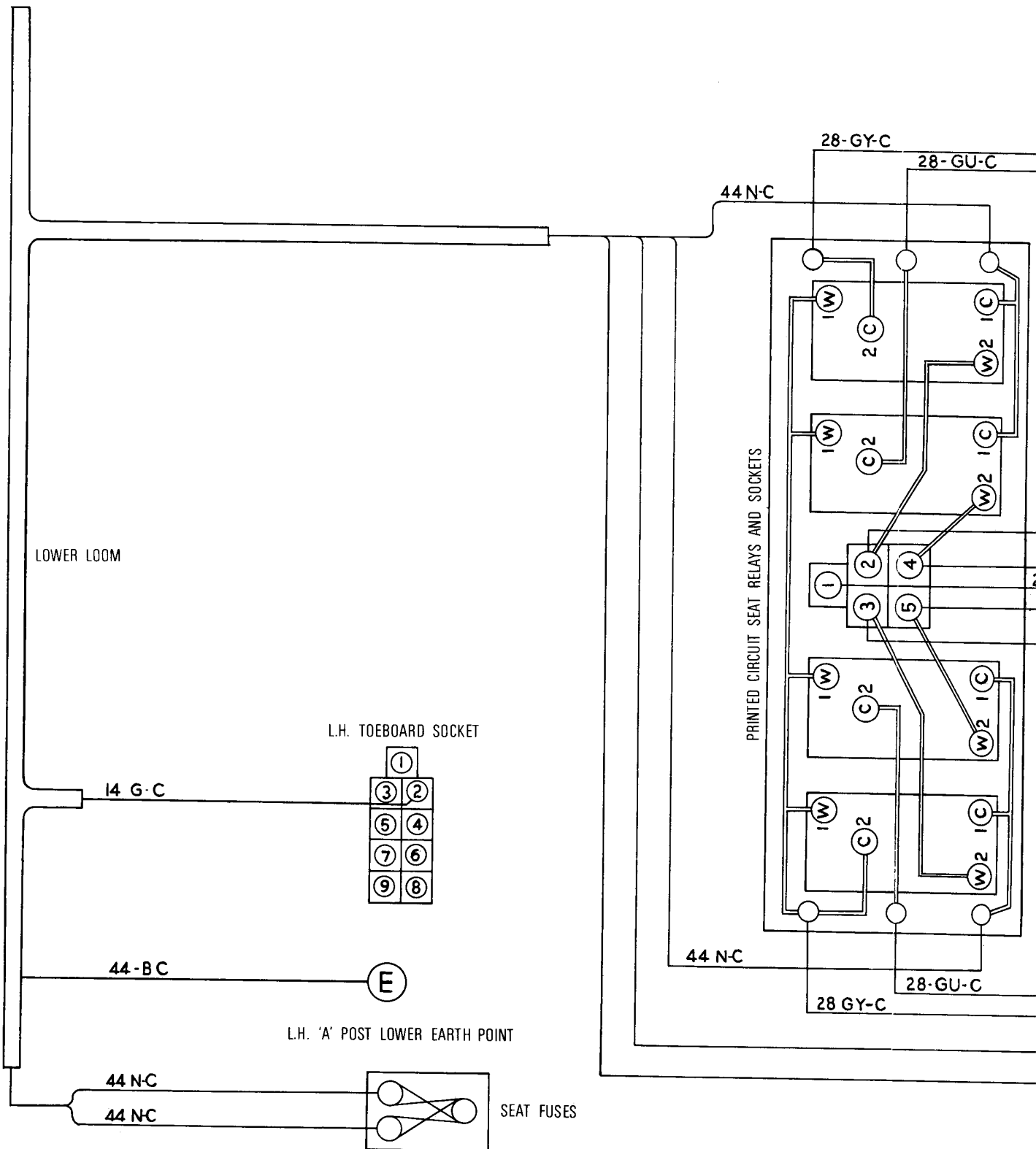

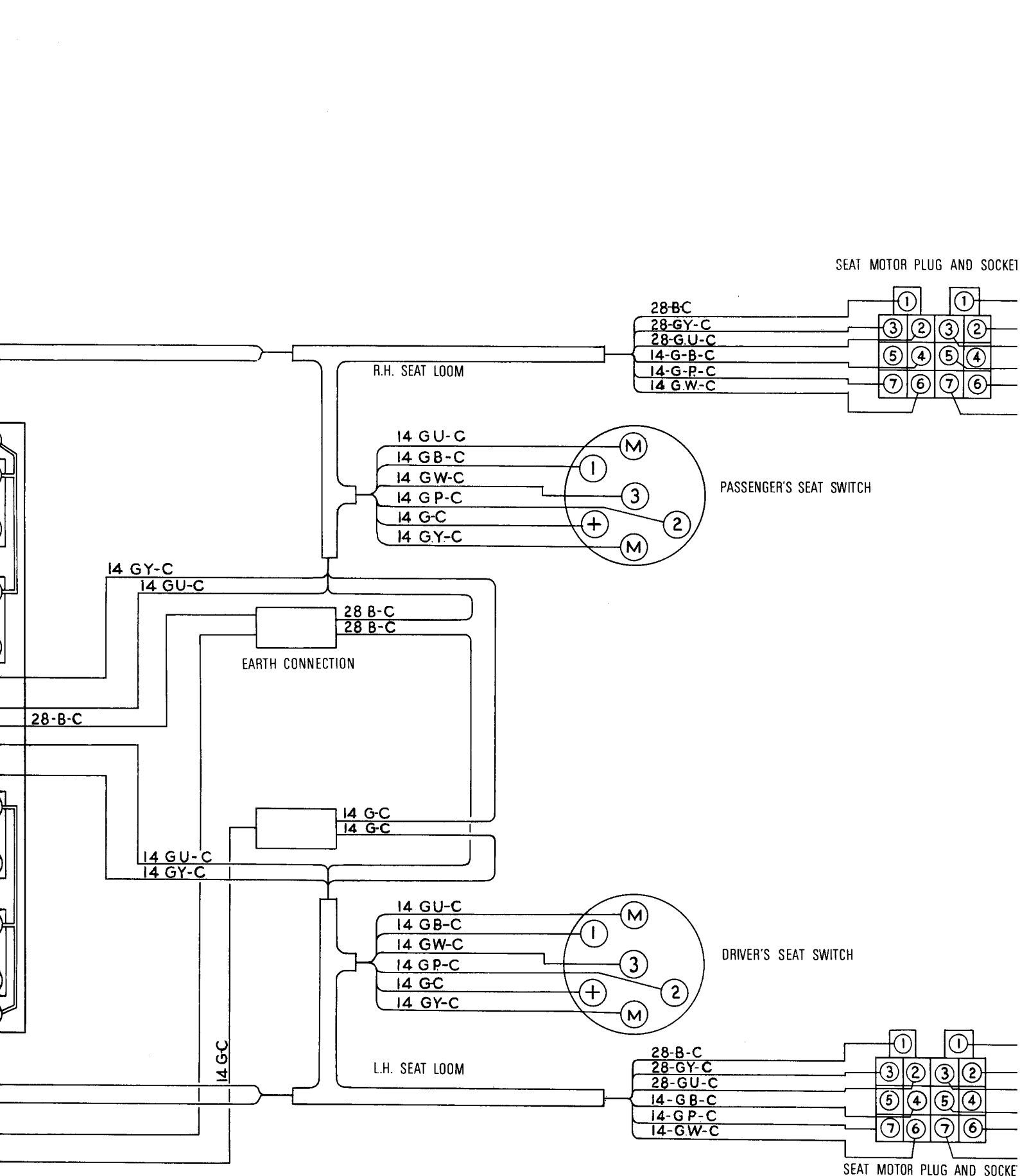

SEAT MOTOR PLUG AND SOCKET

R.H. SEAT LOOM

28-B-C
28-GY-C
28-GU-C
14-G-B-C
14-G-P-C
14-G-W-C

14 GU-C
14 GB-C
14 GW-C
14 GP-C
14 G-C
14 GY-C

PASSENGER'S SEAT SWITCH

EARTH CONNECTION

28-B-C

14 G-C
14 G-C

14 GU-C
14 GY-C

14 GU-C
14 GB-C
14 GW-C
14 GP-C
14 G-C
14 GY-C

DRIVER'S SEAT SWITCH

L.H. SEAT LOOM

28-B-C
28-GY-C
28-GU-C
14-G-B-C
14-G-P-C
14-G-W-C

SEAT MOTOR PLUG AND SOCKET

PASSENGER'S SEAT MOTOR CLUTCHES

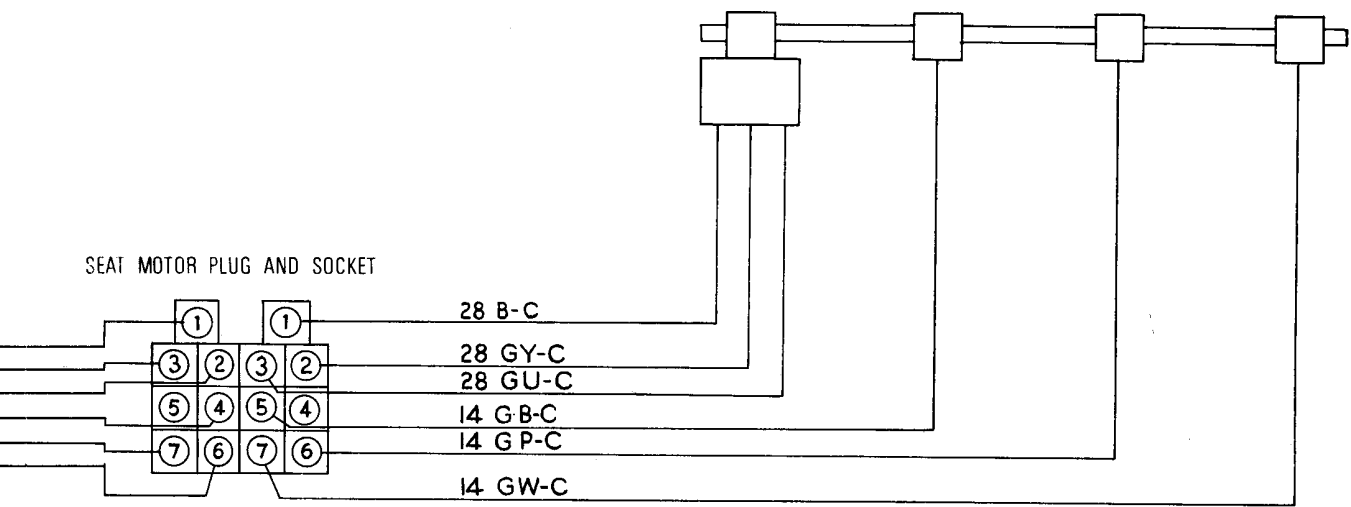

DRIVER'S SEAT SWITCH

KEY TO DIAGRAM

CABLE COLOURS		
B - BLACK	N - BROWN	R - RED
P - PURPLE	U - BLUE	G - GREEN
Y - YELLOW	W - WHITE	S - SLATE

EXAMPLE ○ — UP-P

BLUE BASE WITH PURPLE TRACER PLASTIC COVERED
 FIRST COLOUR AS BASE SECOND COLOUR AS TRACER

SUFFIX P - PLASTIC COVERED CABLE
 SUFFIX C - COTTON COVERED CABLE

SEAT SWITCH

DRIVER'S SEAT MOTOR CLUTCHES

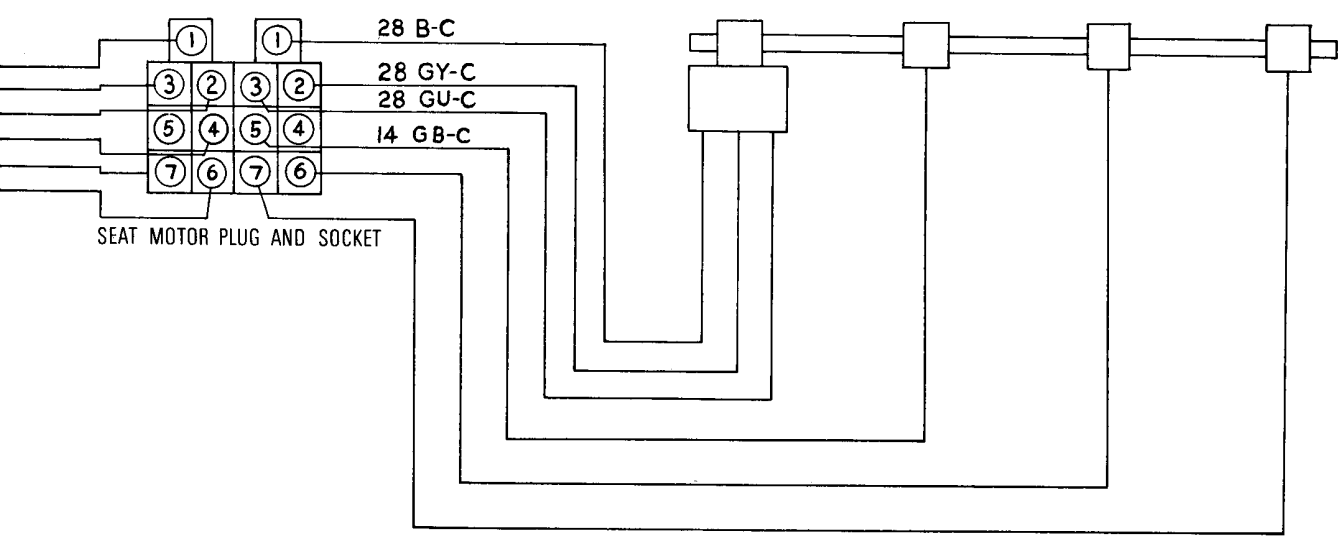

PRACTICAL WIRING DIAGRAM

SHEET 3

LIGHTING

ROLLS-ROYCE SILVER SHADOW AND BENTLEY T SERIES LEFT-HAND DRIVE CARS PRIOR TO CAR SERIAL NUMBER SRX 6000

TSD Publication 2571

© Rolls-Royce Limited 1969

Rolls-Royce policy is one of continuous engineering improvement and the right is reserved to revise the contents of this publication without prior notice.

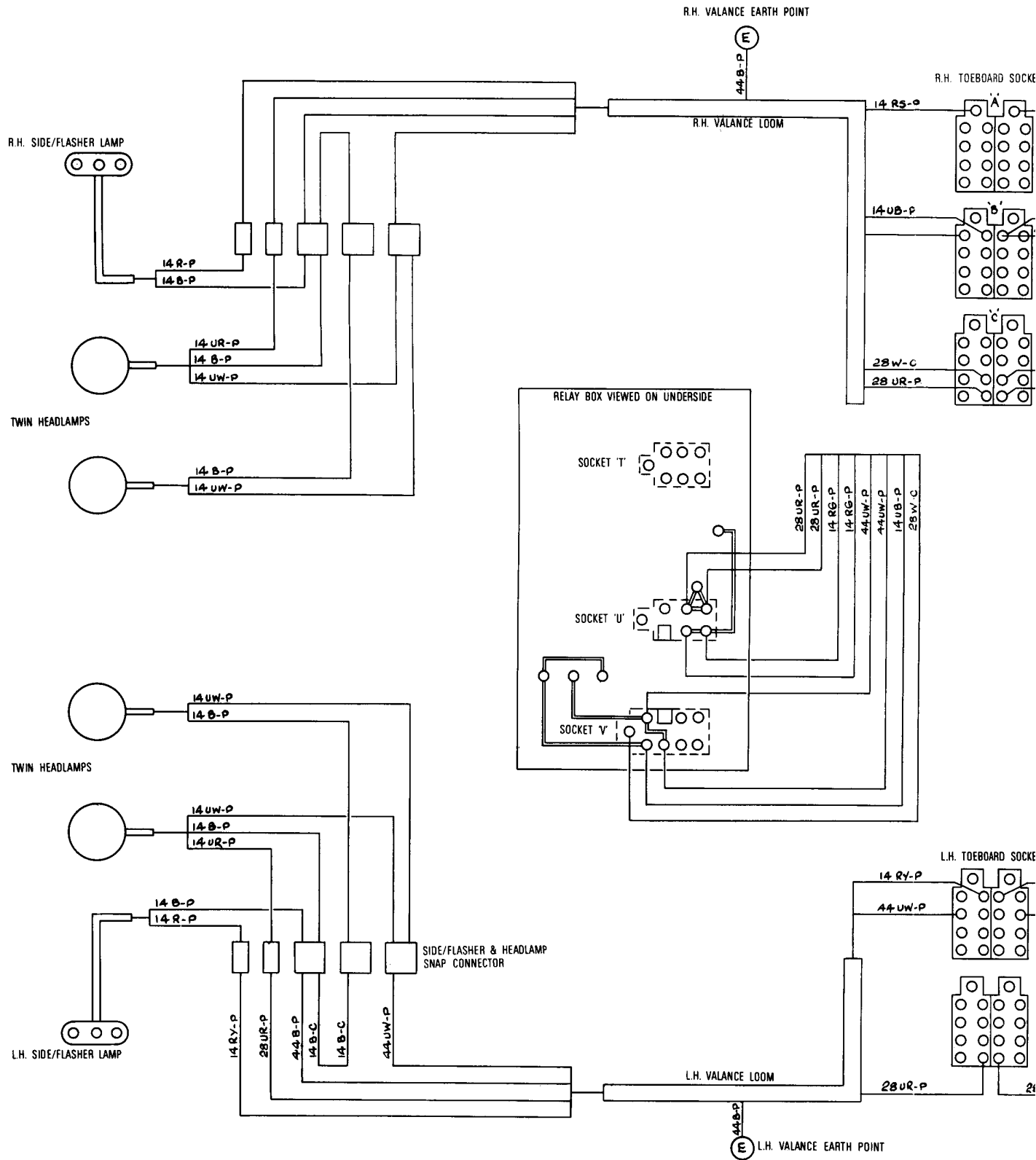

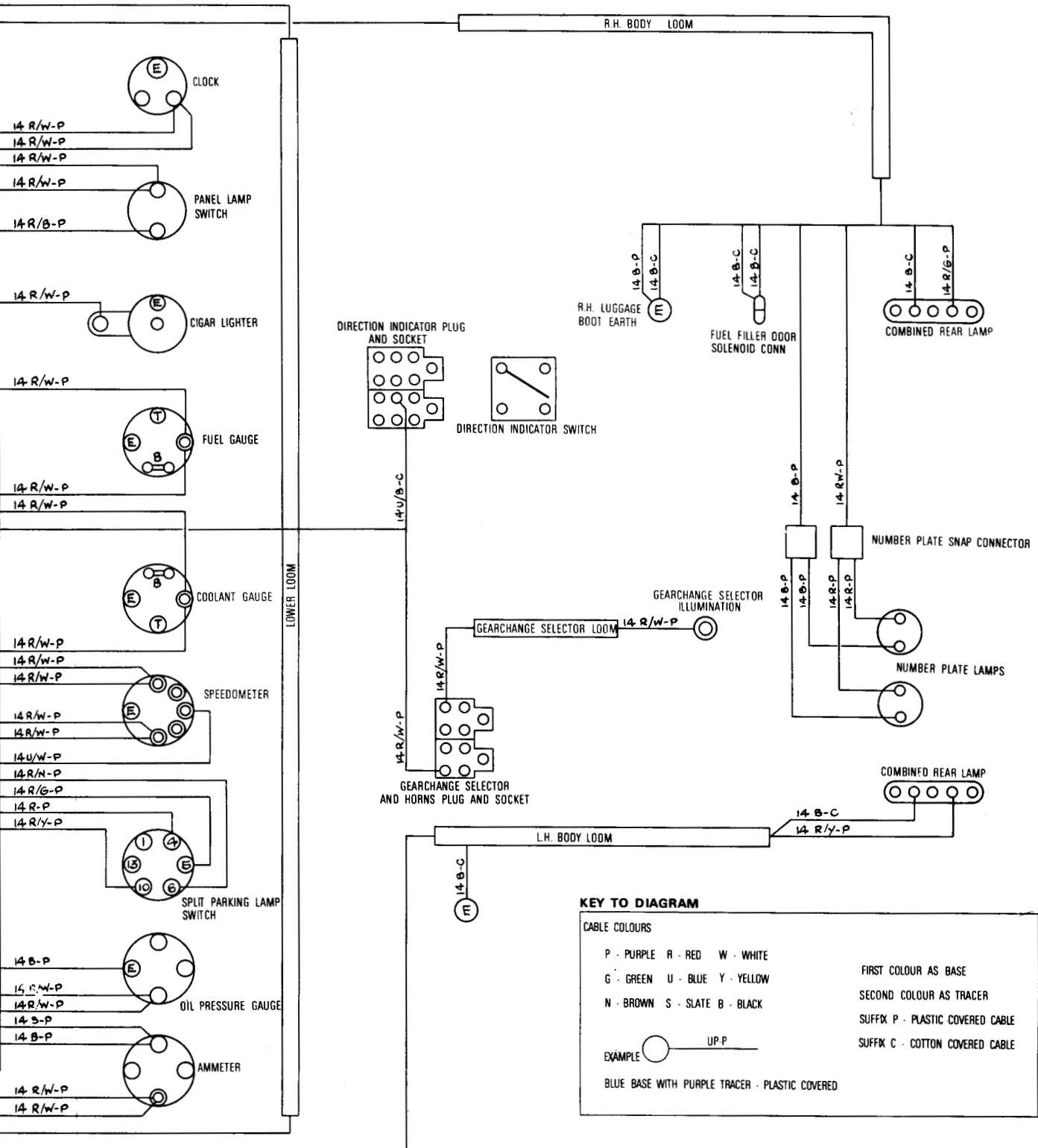

PRACTICAL WIRING DIAGRAM

SHEET 4

ELECTRICALLY OPERATED WINDOWS

**ROLLS-ROYCE SILVER SHADOW
AND**

BENTLEY T SERIES

LEFT-HAND DRIVE CARS

PRIOR TO CAR SERIAL NUMBER SRX 6000

TSD Publication 2571

© Rolls-Royce Limited 1969

Rolls-Royce policy is one of continuous engineering improvement and the right is reserved to revise the contents of this publication without prior notice.

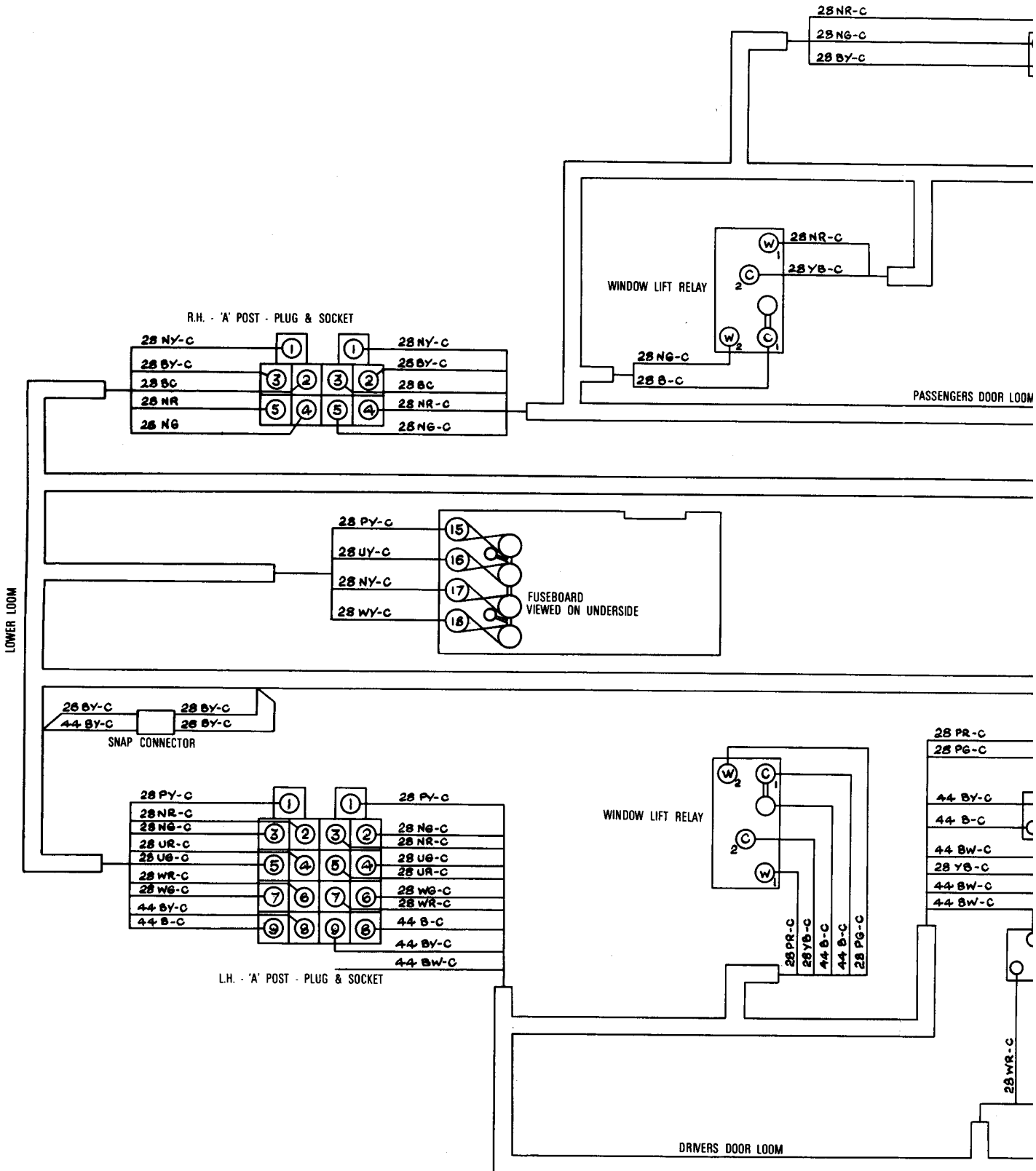

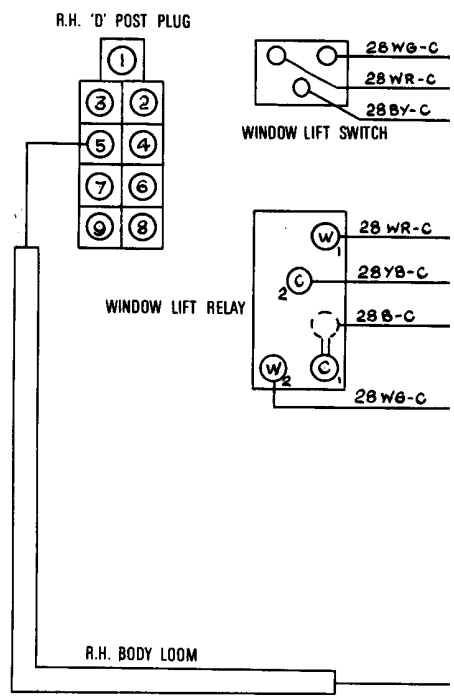
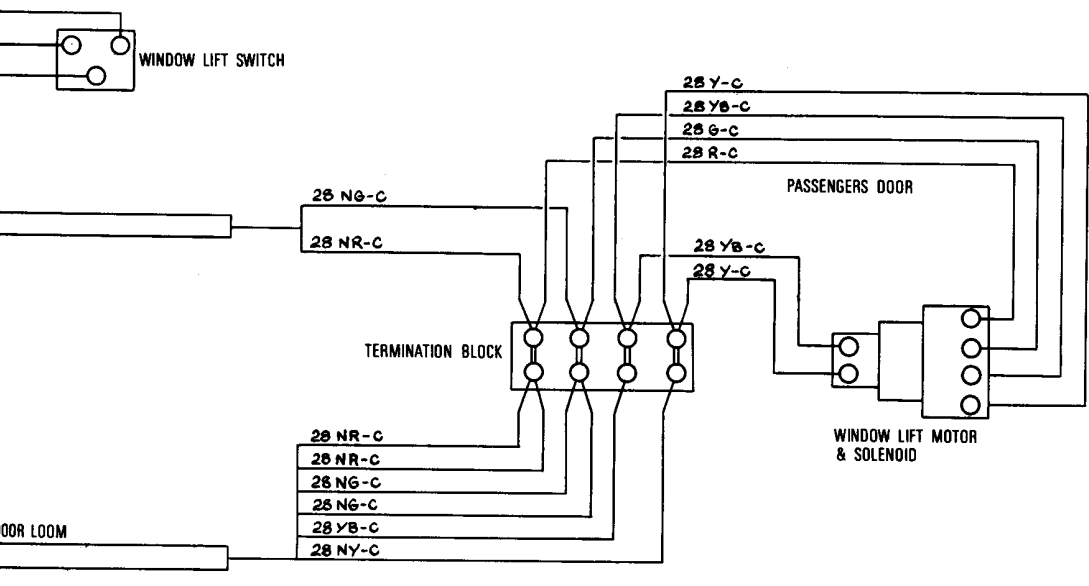

R.H. - 'A' POST EARTH POINT (E) 28 B-C

L.H. - 'A' POST EARTH POINT (E) 44 B-C

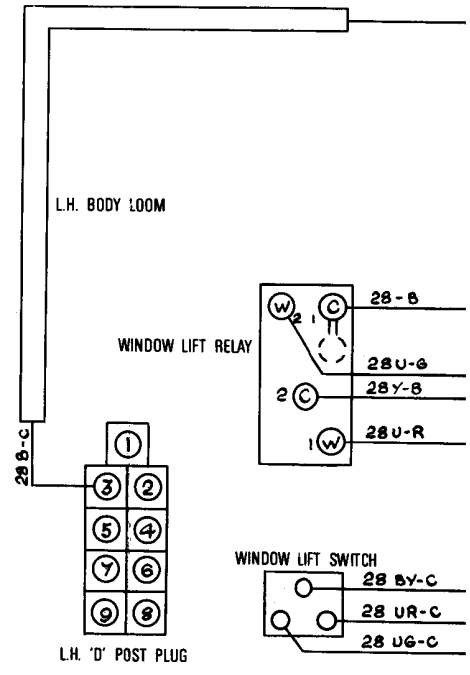
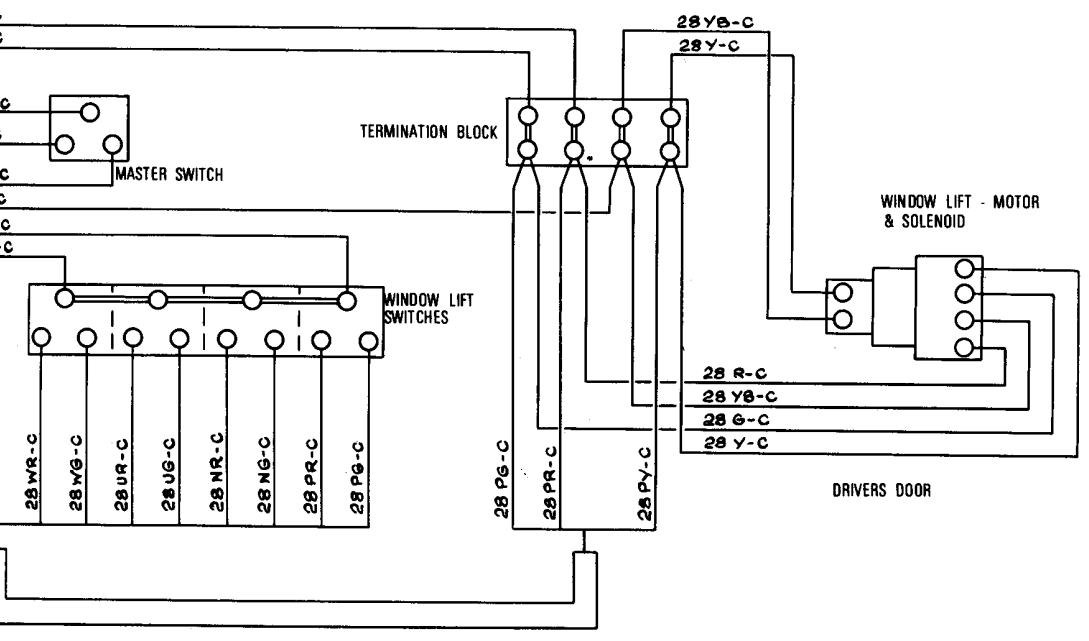

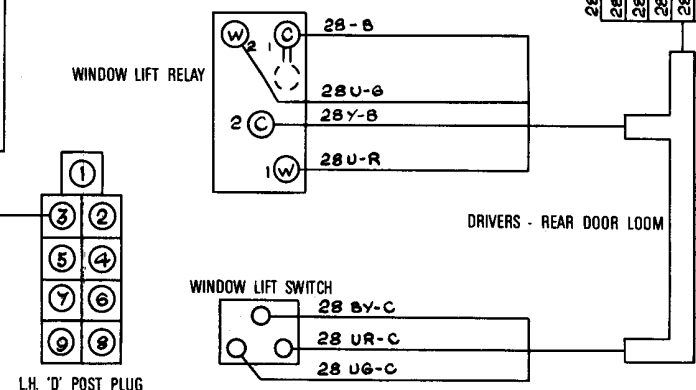
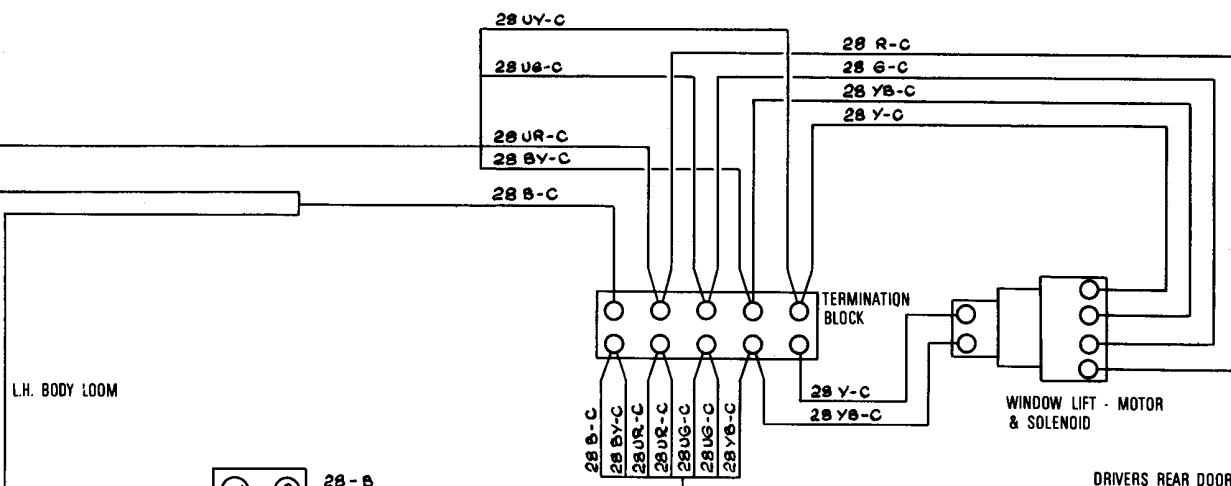
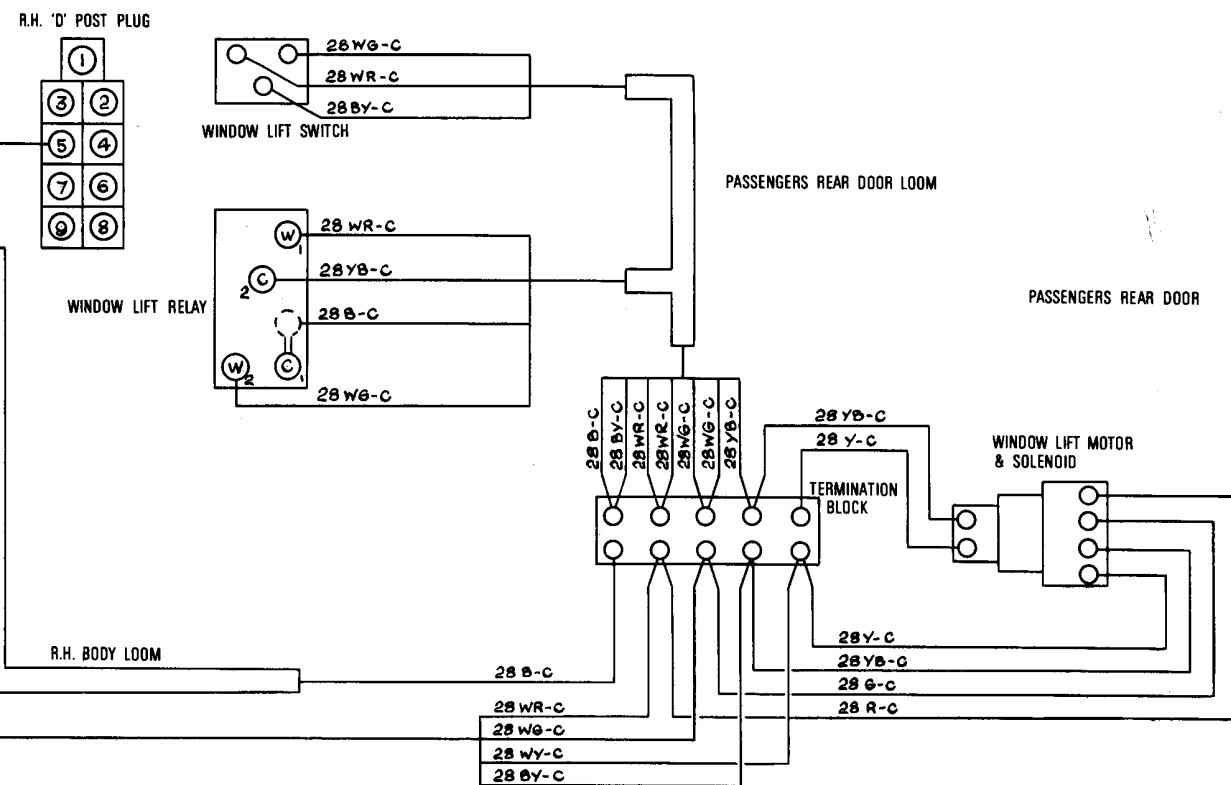

KEY TO DIAGRAM

CABLE COLOURS

- P - PURPLE R - RED W - WHITE
- G - GREEN U - BLUE Y - YELLOW
- N - BROWN S - SLATE B - BLACK

EXAMPLE

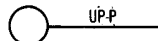

BLUE BASE WITH PURPLE TRACER - PLASTIC COVERED

FIRST COLOUR AS BASE

SECOND COLOUR AS TRACER

SUFFIX P - PLASTIC COVERED CABLE

SUFFIX C - COTTON COVERED CABLE

PRACTICAL WIRING DIAGRAM

SHEET 5

STARTER & IGNITION

ROLLS-ROYCE SILVER SHADOW AND BENTLEY T SERIES LEFT-HAND DRIVE CARS PRIOR TO CAR SERIAL NUMBER SRX 6000

TSD Publication 2571

© Rolls-Royce Limited 1969

Rolls-Royce policy is one of continuous engineering improvement and the right is reserved to revise the contents of this publication without prior notice.

28 B-C

R.H. VALANCE EARTH POINT

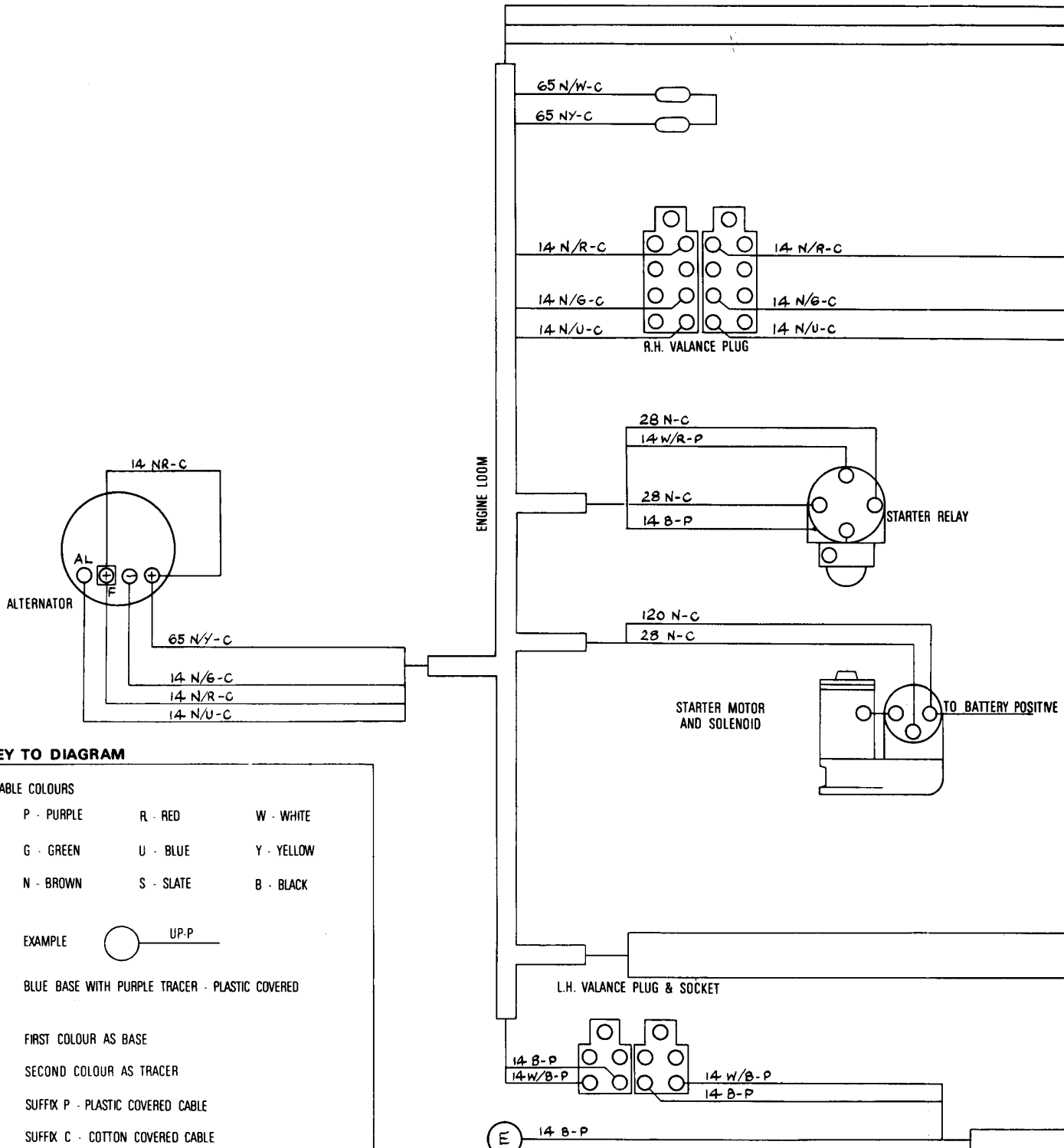

KEY TO DIAGRAM

CABLE COLOURS

- | | | |
|------------|-----------|------------|
| P - PURPLE | R - RED | W - WHITE |
| G - GREEN | U - BLUE | Y - YELLOW |
| N - BROWN | S - SLATE | B - BLACK |



BLUE BASE WITH PURPLE TRACER - PLASTIC COVERED

FIRST COLOUR AS BASE

SECOND COLOUR AS TRACER

SUFFIX P - PLASTIC COVERED CABLE

SUFFIX C - COTTON COVERED CABLE

14 B-P

L.H. VALANCE EARTH POINT

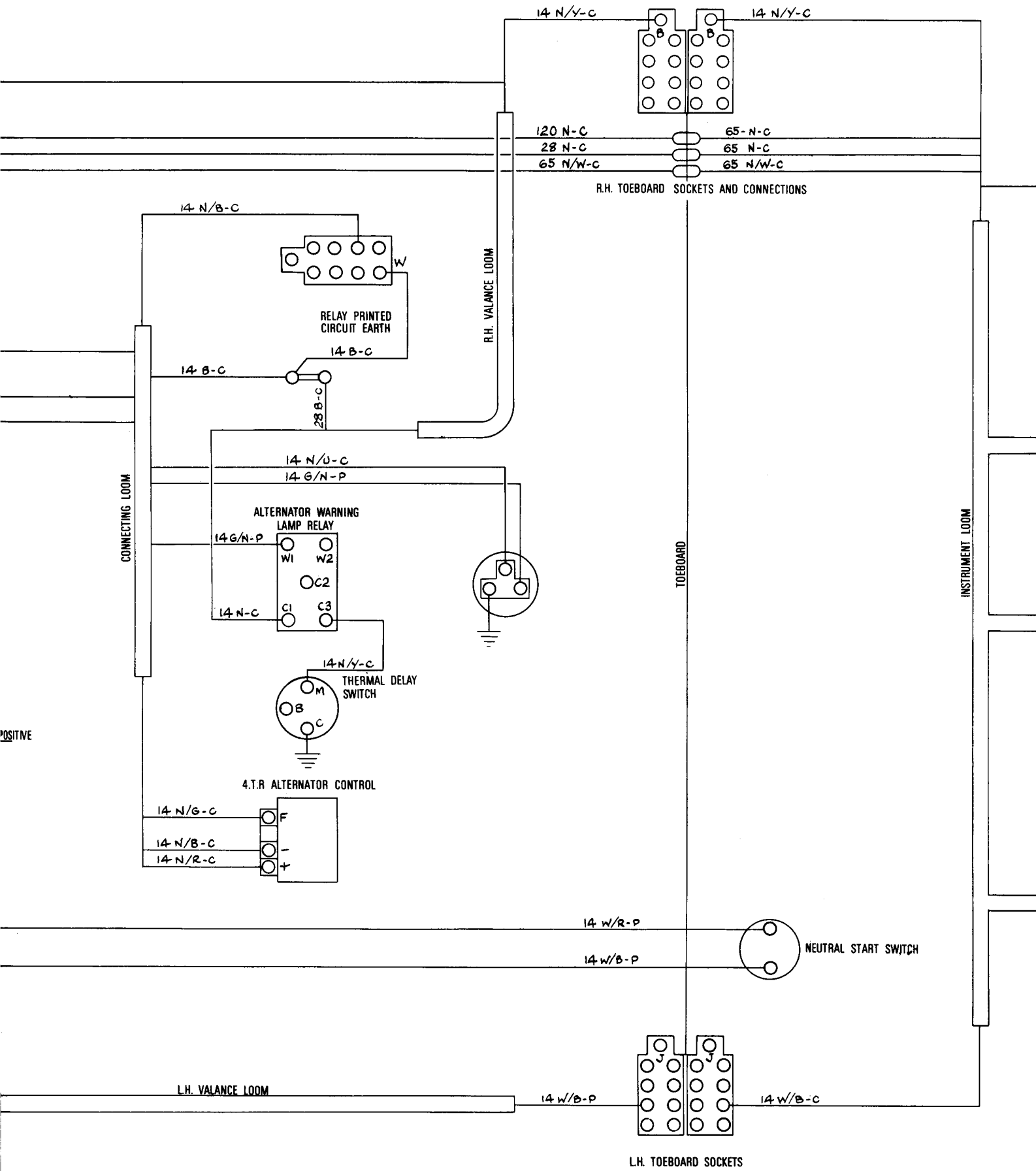

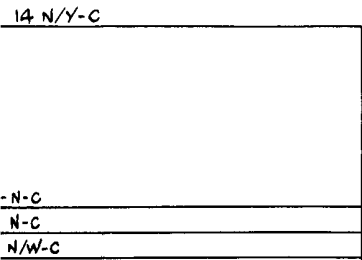

CONNECTIONS

INSTRUMENT LOOM

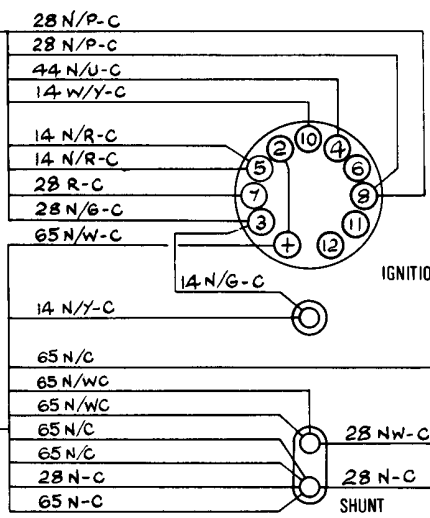

SWITCHBOX

IGNITION WARNING LAMP

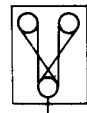

SEAT FUSES

AMMETER

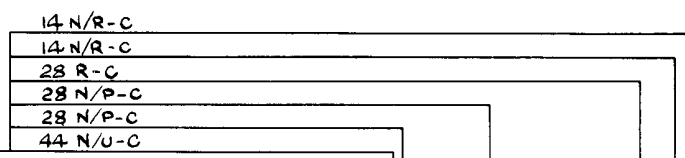

FUSEBOARD VIEWED ON UNDERSIDE

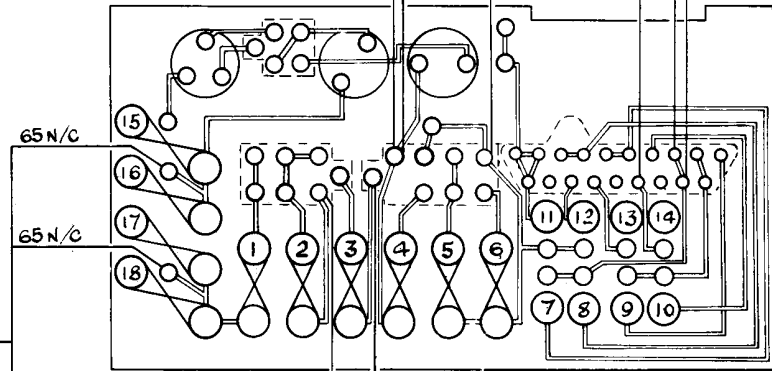

28 N/G-C

28 N-C

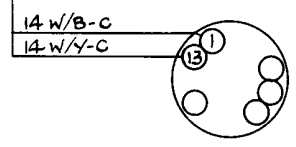

SPLIT PARKING LAMP SWITCH

14 W/B-C



PRACTICAL WIRING DIAGRAM

SHEET 6

AIR CONDITIONING UNIT

ROLLS-ROYCE SILVER SHADOW

AND

BENTLEY T SERIES

LEFT-HAND DRIVE CARS

PRIOR TO CAR SERIAL NUMBER SRX 6000

TSD Publication 2571

© Rolls-Royce Limited 1969

Rolls-Royce policy is one of continuous engineering improvement and the right is reserved to revise the contents of this publication without prior notice.

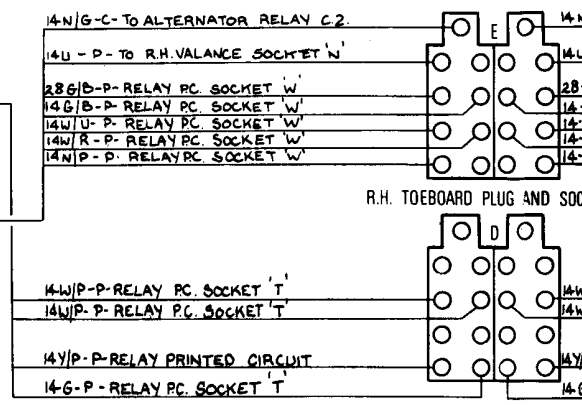
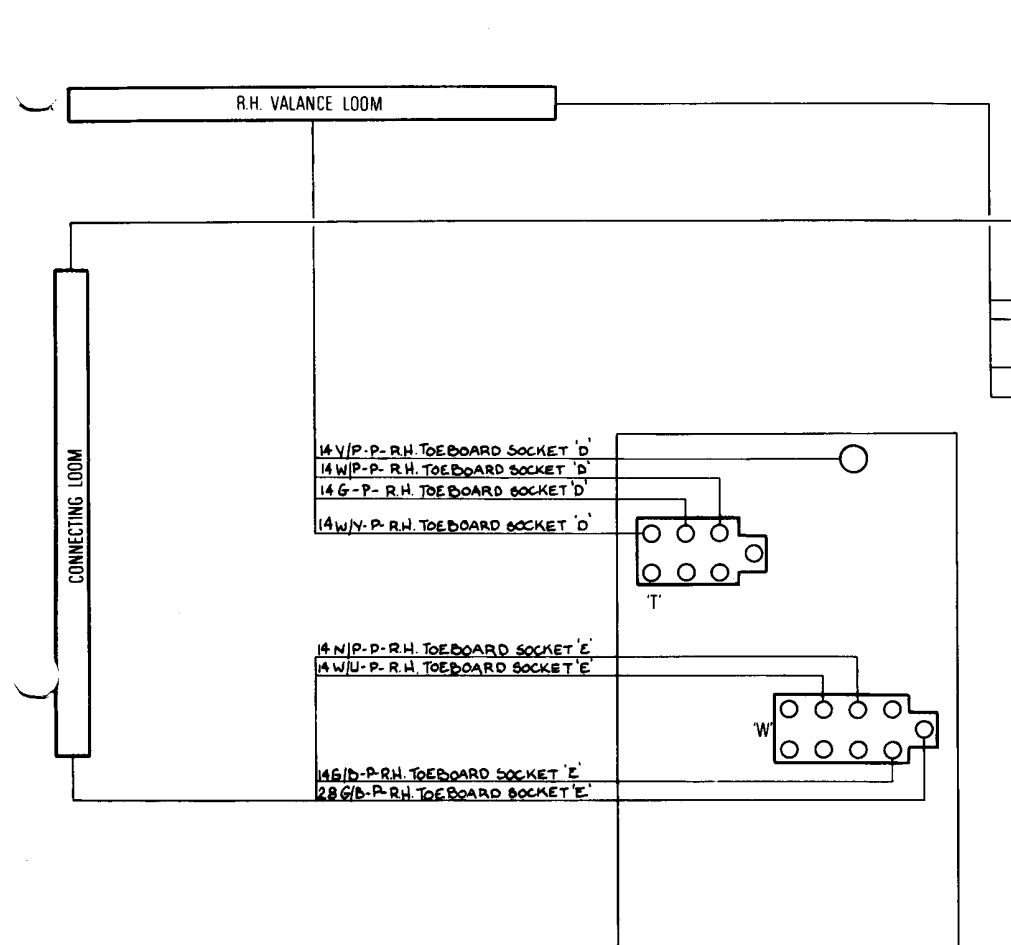

RELAY PRINTED CIRCUIT BOARD

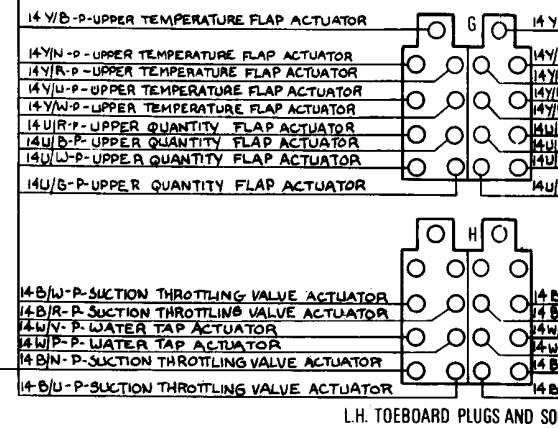
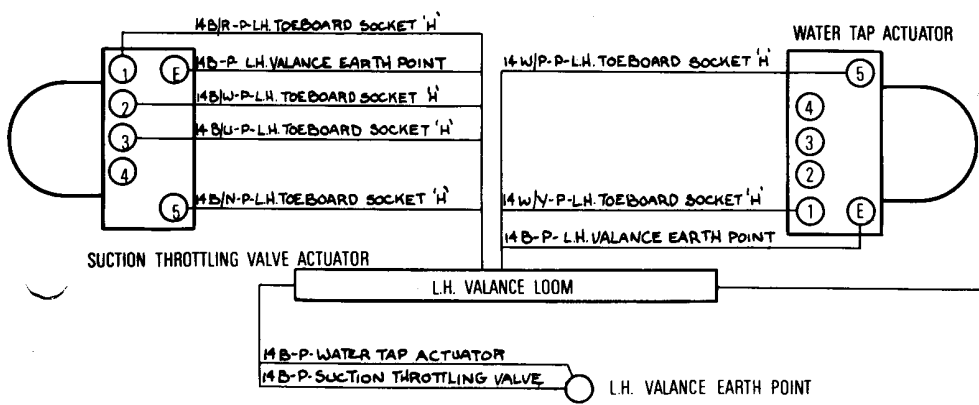
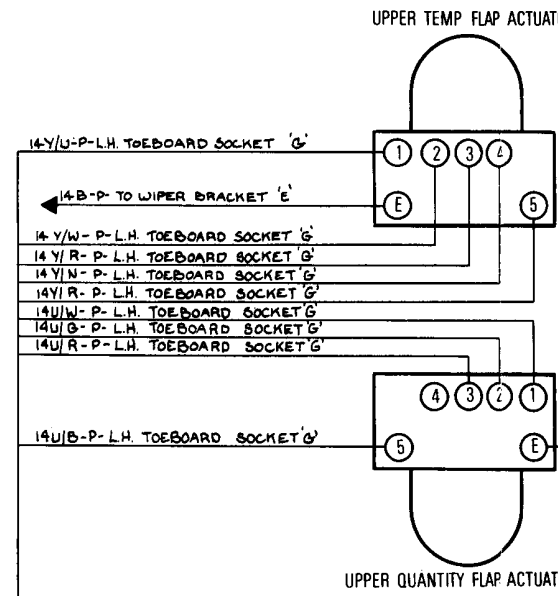

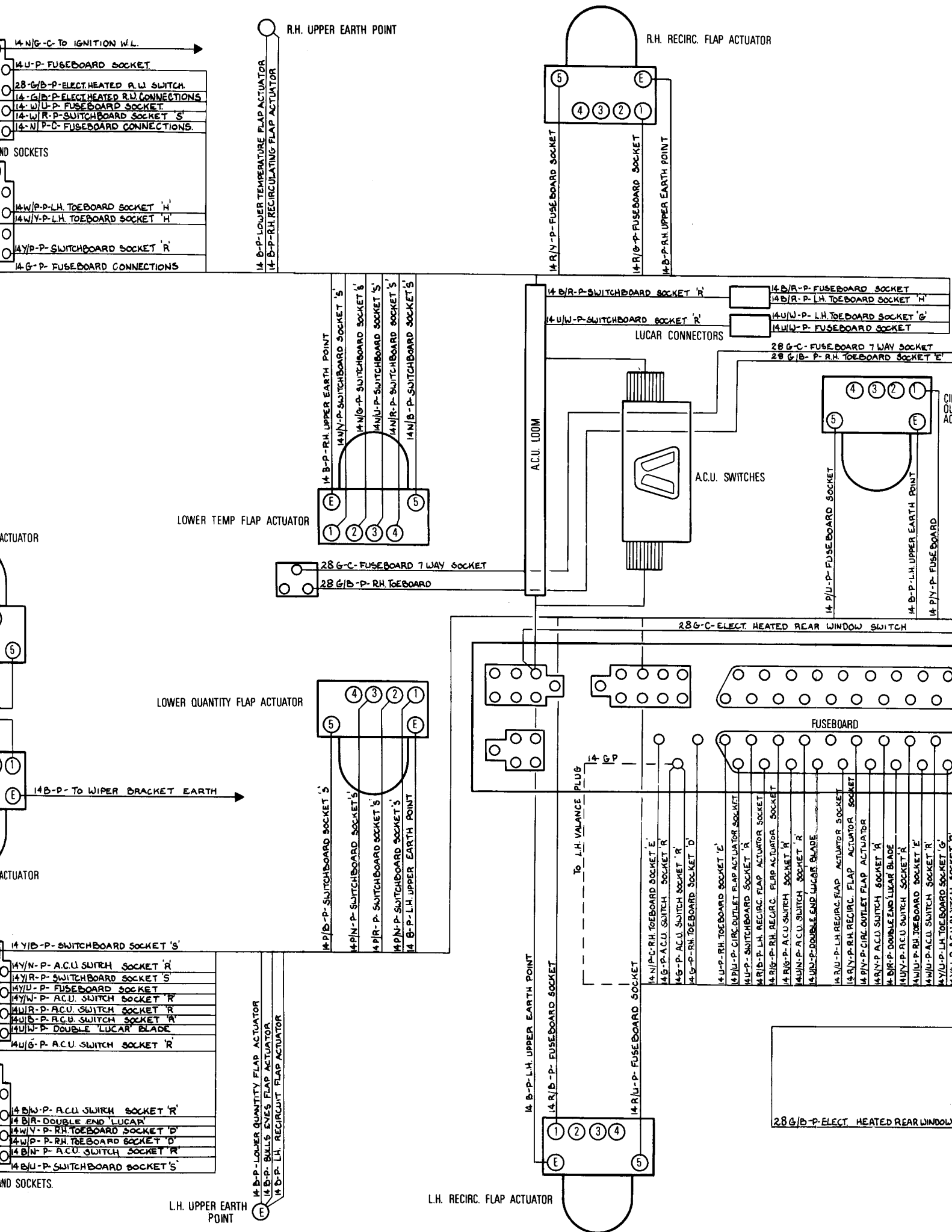

- 14 N/G-C-TO IGNITION W/L.
- 14 U-P-FUSEBOARD SOCKET
- 28 G/B-P-ELECT HEATED R.W. SWITCH
- 14 G/B-P-ELECT HEATED R.W. CONNECTIONS
- 14 W/U-P-FUSEBOARD SOCKET
- 14 W/R-P-SWITCHBOARD SOCKET 'S'
- 14 N/P-C-FUSEBOARD CONNECTIONS

- ND SOCKETS
- 14 W/P-P-LH TOEBOARD SOCKET 'H'
- 14 W/Y-P-LH TOEBOARD SOCKET 'H'
- 14 Y/P-P-SWITCHBOARD SOCKET 'R'
- 14 G-P-FUSEBOARD CONNECTIONS

- 14 B-P-LOWER TEMPERATURE FLAP ACTUATOR
- 14 B-P-RH RECIRCULATING FLAP ACTUATOR
- R.H. UPPER EARTH POINT

- 14 R/N-P-FUSEBOARD SOCKET
- 14 R/B-P-FUSEBOARD SOCKET
- 14 B-P-RH UPPER EARTH POINT
- 14 B/R-P-SWITCHBOARD SOCKET 'R'
- 14 U/W-P-SWITCHBOARD SOCKET 'R'
- 14 B/R-P-FUSEBOARD SOCKET
- 14 B/R-P-LH TOEBOARD SOCKET 'H'
- 14 U/W-P-LH TOEBOARD SOCKET 'G'
- 14 U/W-P-FUSEBOARD SOCKET
- 28 G-C-FUSEBOARD 7 WAY SOCKET
- 28 G/B-P-RH TOEBOARD SOCKET 'E'

- 14 B-P-RH UPPER EARTH POINT
- 14 N/P-SWITCHBOARD SOCKET 'S'
- 14 N/G-P-SWITCHBOARD SOCKET 'G'
- 14 N/U-P-SWITCHBOARD SOCKET 'S'
- 14 N/R-P-SWITCHBOARD SOCKET 'S'
- 14 N/B-P-SWITCHBOARD SOCKET 'S'

LOWER TEMP FLAP ACTUATOR

- 28 G-C-FUSEBOARD 7 WAY SOCKET
- 28 G/B-P-RH TOEBOARD

LOWER QUANTITY FLAP ACTUATOR

- 14 P/B-P-SWITCHBOARD SOCKET 'S'
- 14 P/N-P-SWITCHBOARD SOCKET 'S'
- 14 P/R-P-SWITCHBOARD SOCKET 'S'
- 14 P/N-P-SWITCHBOARD SOCKET 'S'
- 14 B-P-LH UPPER EARTH POINT

14 B-P-TO WIPER BRACKET EARTH

- 14 Y/B-P-SWITCHBOARD SOCKET 'S'
- 14 Y/N-P-ACU SWITCH SOCKET 'R'
- 14 Y/R-P-SWITCHBOARD SOCKET 'S'
- 14 Y/U-P-FUSEBOARD SOCKET
- 14 Y/W-P-ACU SWITCH SOCKET 'R'
- 14 Y/W-P-ACU SWITCH SOCKET 'R'
- 14 Y/G-P-RCB SWITCH SOCKET 'R'
- 14 Y/W-P-DOUBLE 'LUCAR' BLADE
- 14 Y/G-P-ACU SWITCH SOCKET 'R'

- 14 B-P-LOWER QUANTITY FLAP ACTUATOR
- 14 B-P-EYES FLAP ACTUATOR
- 14 B-P-LH RECIRCULATING FLAP ACTUATOR

L.H. UPPER EARTH POINT

- 14 B/W-P-ACU SWITCH SOCKET 'R'
- 14 B/R-DOUBLE END 'LUCAR'
- 14 W/V-P-RH TOEBOARD SOCKET 'D'
- 14 W/P-P-RH TOEBOARD SOCKET 'D'
- 14 B/N-P-ACU SWITCH SOCKET 'R'
- 14 B/U-P-SWITCHBOARD SOCKET 'S'

ND SOCKETS.

L.H. RECIRC. FLAP ACTUATOR

- 14 B-P-LH UPPER EARTH POINT
- 14 R/B-P-FUSEBOARD SOCKET
- 14 R/U-P-FUSEBOARD SOCKET
- 14 N/P-C-RH TOEBOARD SOCKET 'E'
- 14 B-P-ACU SWITCH SOCKET 'R'
- 14 G-P-ACU SWITCH SOCKET 'R'
- 14 B-P-RH TOEBOARD SOCKET 'D'
- 14 U-P-RH TOEBOARD SOCKET 'E'
- 14 P/U-P-CIRC. OUTLET FLAP ACTUATOR SOCKET
- 14 P-P-SWITCHBOARD SOCKET 'R'
- 14 R/B-P-LH RECIRC. FLAP ACTUATOR SOCKET
- 14 R/G-P-RH RECIRC. FLAP ACTUATOR SOCKET
- 14 R/G-P-ACU SWITCH SOCKET 'R'
- 14 U/N-P-ACU SWITCH SOCKET 'R'
- 14 W/P-DOUBLE END 'LUCAR' BLADE
- 14 R/U-P-LH RECIRC. FLAP ACTUATOR SOCKET
- 14 R/N-P-RH RECIRC. FLAP ACTUATOR SOCKET
- 14 P/V-P-CIRC. OUTLET FLAP ACTUATOR
- 14 R/P-ACU SWITCH SOCKET 'R'
- 14 B/R-P-DOUBLE END 'LUCAR' BLADE
- 14 U/V-P-ACU SWITCH SOCKET 'R'
- 14 U/W-P-RH TOEBOARD SOCKET 'E'
- 14 U/P-ACU SWITCH SOCKET 'R'
- 14 Y/U-P-LH TOEBOARD SOCKET 'G'
- 14 W/LB-P-RH TOEBOARD SOCKET 'B'

28 G/B-P-ELECT HEATED REAR WINDOW

C. FLAP ACTUATOR

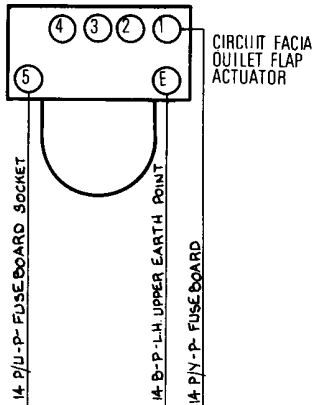
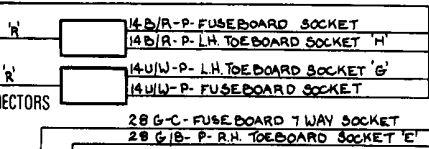
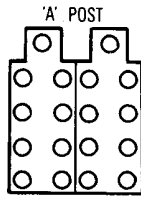

16-C-ELECT. HEATED REAR WINDOW SWITCH

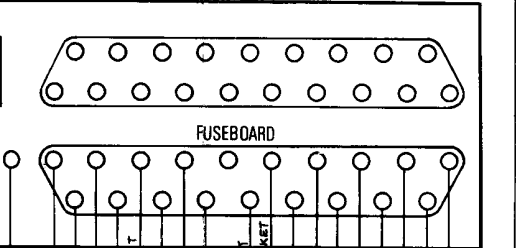

- 14 U/P-RH TOEBOARD SOCKET 'E'
- 14 U/P-CIRC. OUTLET FLAP ACTUATOR SOCKET 'R'
- 14 U/P-P. SWITCHBOARD SOCKET 'R'
- 14 R/B-P. LH. RECIRC. FLAP ACTUATOR SOCKET
- 14 R/G-P. RH. RECIRC. FLAP ACTUATOR SOCKET
- 14 U/N-P. AC.U. SWITCH SOCKET 'R'
- 14 U/W-P. AC.U. SWITCH SOCKET 'R'
- 14 U/W-P. DOUBLE END LUGAR BLADE
- 14 R/U-P. LH. RECIRC. FLAP ACTUATOR SOCKET
- 14 R/Y-P. RH. RECIRC. FLAP ACTUATOR SOCKET
- 14 P/N-P. CIRC. OUTLET FLAP ACTUATOR SOCKET
- 14 R/N-P. AC.U. SWITCH SOCKET 'R'
- 14 U/Y-P. AC.U. SWITCH SOCKET 'R'
- 14 U/W-P. RH. TOEBOARD SOCKET 'E'
- 14 W/U-P. LH. TOEBOARD SOCKET 'G'
- 14 Y/U-P. AC.U. SWITCH SOCKET 'R'

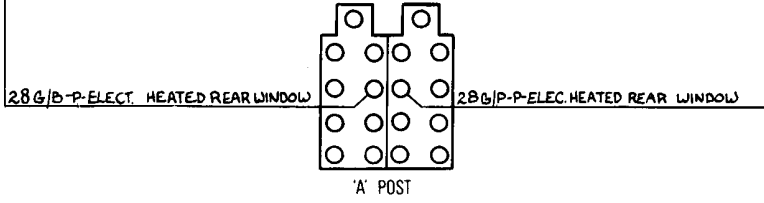

AIR CONDITIONING UNIT SWITCHES ENLARGED VIEW

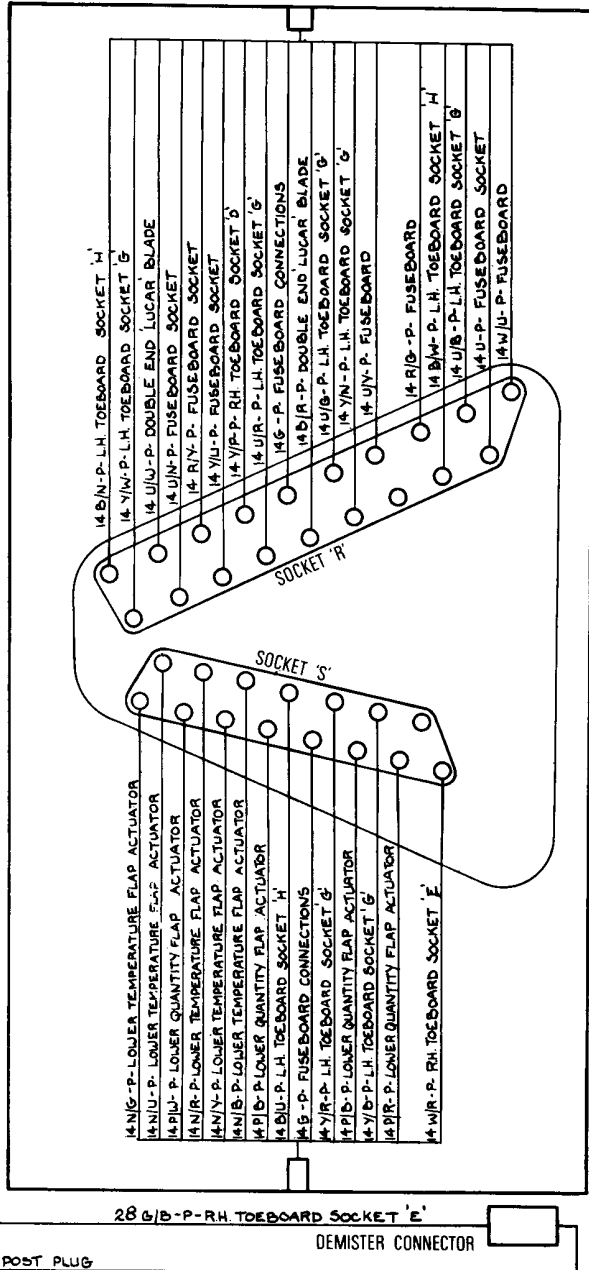

18 G/P-P. LH. 'A' POST LOWER SOCKET.



KEY TO DIAGRAM

CABLE COLOUR CODE

B = BLACK	P = PURPLE	U = BLUE
G = GREEN	R = RED	W = WHITE
N = BROWN	S = SLATE	Y = YELLOW

CABLE SIZES

14 = 14/.010	28 = 28/.012	120 = 120/.012
44 = 44/.012	65 = 65/.012	

CABLE TYPE

'C' DENOTES COTTON COVERED CABLE
'P' DENOTES PLASTIC COVERED CABLE

EXAMPLE

PRACTICAL WIRING DIAGRAM

SHEET 7

INTERIOR LIGHTING

ROLLS-ROYCE SILVER SHADOW AND BENTLEY T SERIES LEFT-HAND DRIVE CARS PRIOR TO CAR SERIAL NUMBER SRX 6000

TSD Publication 2571

© Rolls-Royce Limited 1969

Rolls-Royce policy is one of continuous engineering improvement and the right is reserved to revise the contents of this publication without prior notice.

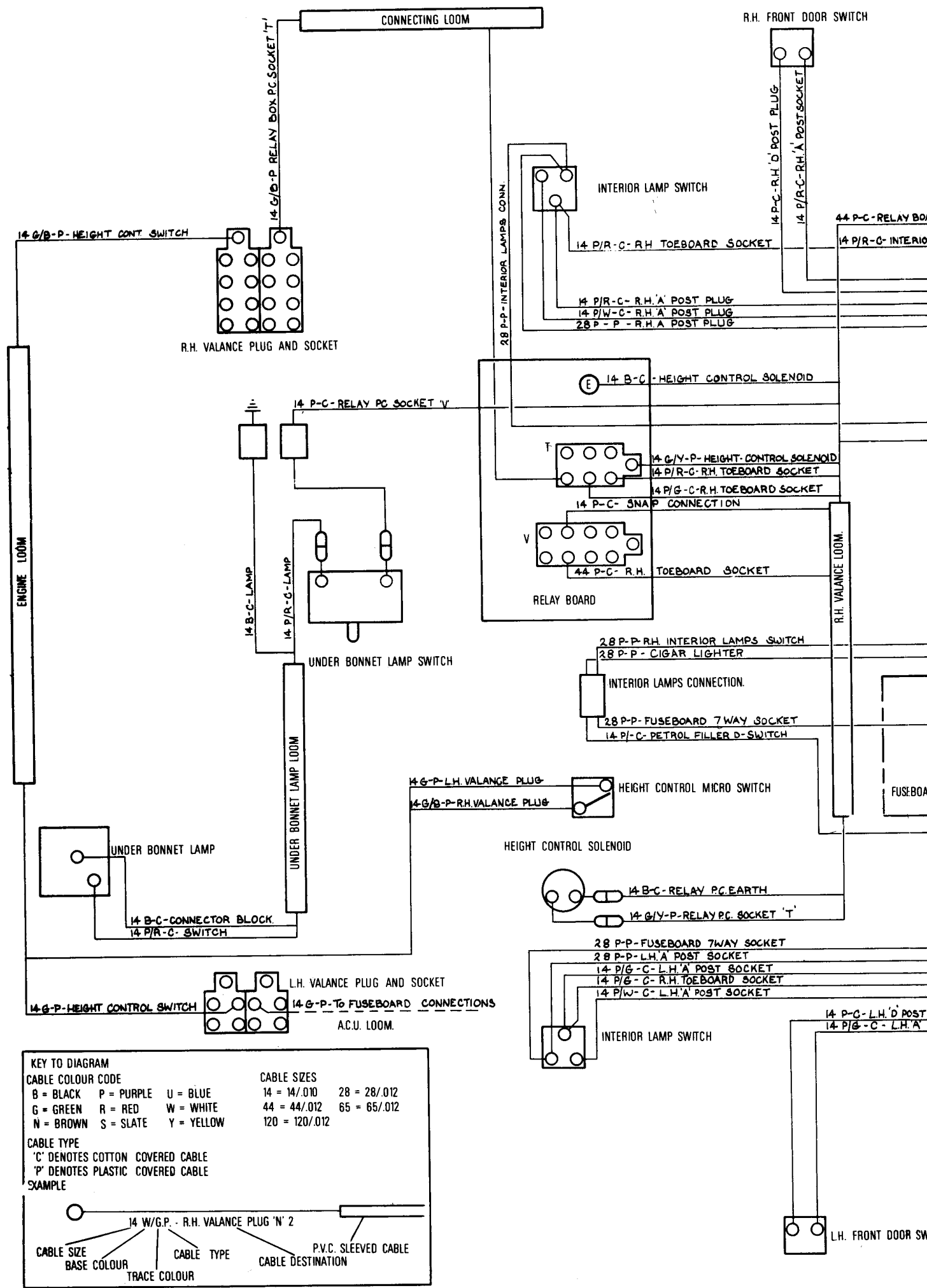

KEY TO DIAGRAM

CABLE COLOUR CODE
 B = BLACK P = PURPLE U = BLUE
 G = GREEN R = RED W = WHITE
 N = BROWN S = SLATE Y = YELLOW

CABLE SIZES
 14 = 14/0.10 28 = 28/0.12
 44 = 44/0.12 65 = 65/0.12
 120 = 120/0.12

CABLE TYPE
 'C' DENOTES COTTON COVERED CABLE
 'P' DENOTES PLASTIC COVERED CABLE

SAMPLE

14 W/G.P. - R.H. VALANCE PLUG 'N' 2

CABLE SIZE BASE COLOUR TRACE COLOUR CABLE TYPE CABLE DESTINATION

P.V.C. SLEEVED CABLE

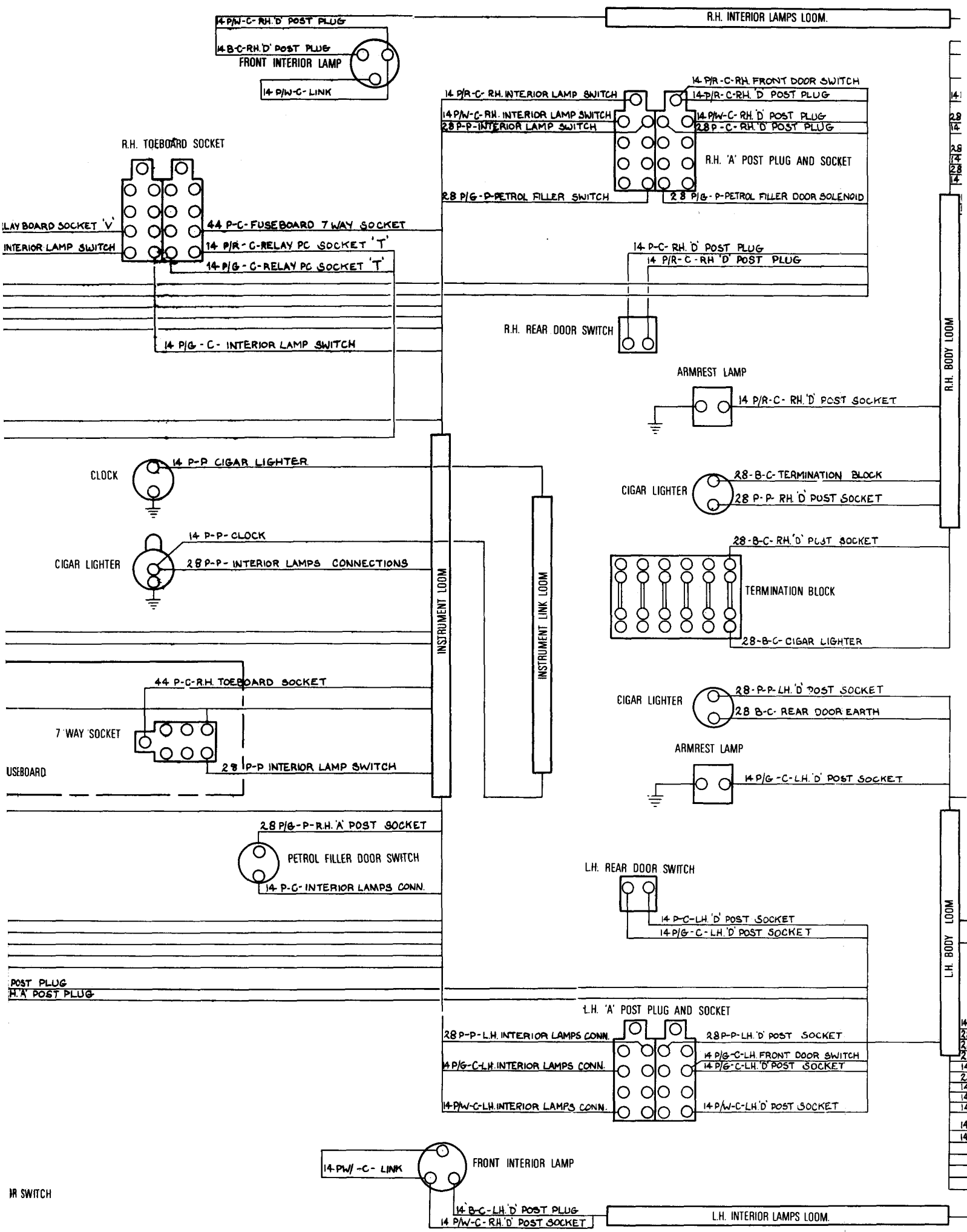

DR SWITCH

R.H. INTERIOR LAMPS LOOM.

14 P/R-C-RH FRONT DOOR SWITCH
14 P/R-C-RH 'D' POST PLUG
14 P/W-C-RH 'D' POST PLUG
14 P-C-RH 'D' POST PLUG

R.H. 'A' POST PLUG AND SOCKET
14 P-C-PETROL FILLER DOOR SOLENOID

14 P/W-C-RH 'A' POST SOCKET
28 B-C DOOR TERMINAL BLOCK
14 P-C-RH FRONT DOOR SWITCH
28 P-P-ARMREST CIGAR LIGHTER
14 P/R-C-RH 'A' POST PLUG
28 B-P-RH 'A' POST PLUG
14 P/R-C-RH ARMREST LAMP

14 P/R-C-RH REAR DOOR SWITCH
14 P-C-RH REAR DOOR SWITCH

14 P/R-C-RH 'D' POST SOCKET
28 B-C-TERMINATION BLOCK
28 P-P-RH 'D' POST SOCKET

28 B-C-RH 'D' POST SOCKET
TERMINATION BLOCK
28 B-C-CIGAR LIGHTER

28 P-P-LH 'D' POST SOCKET
28 B-C-REAR DOOR EARTH

14 P/G-C-LH 'D' POST SOCKET

14 P/W-C-LH 'A' POST SOCKET
14 P/W-C-LH 'D' POST SOCKET

28 P-P-LH 'D' POST SOCKET
14 P/G-C-LH FRONT DOOR SWITCH
14 P/G-C-LH 'D' POST SOCKET

14 P/W-C-LH 'D' POST SOCKET

L.H. INTERIOR LAMPS LOOM.

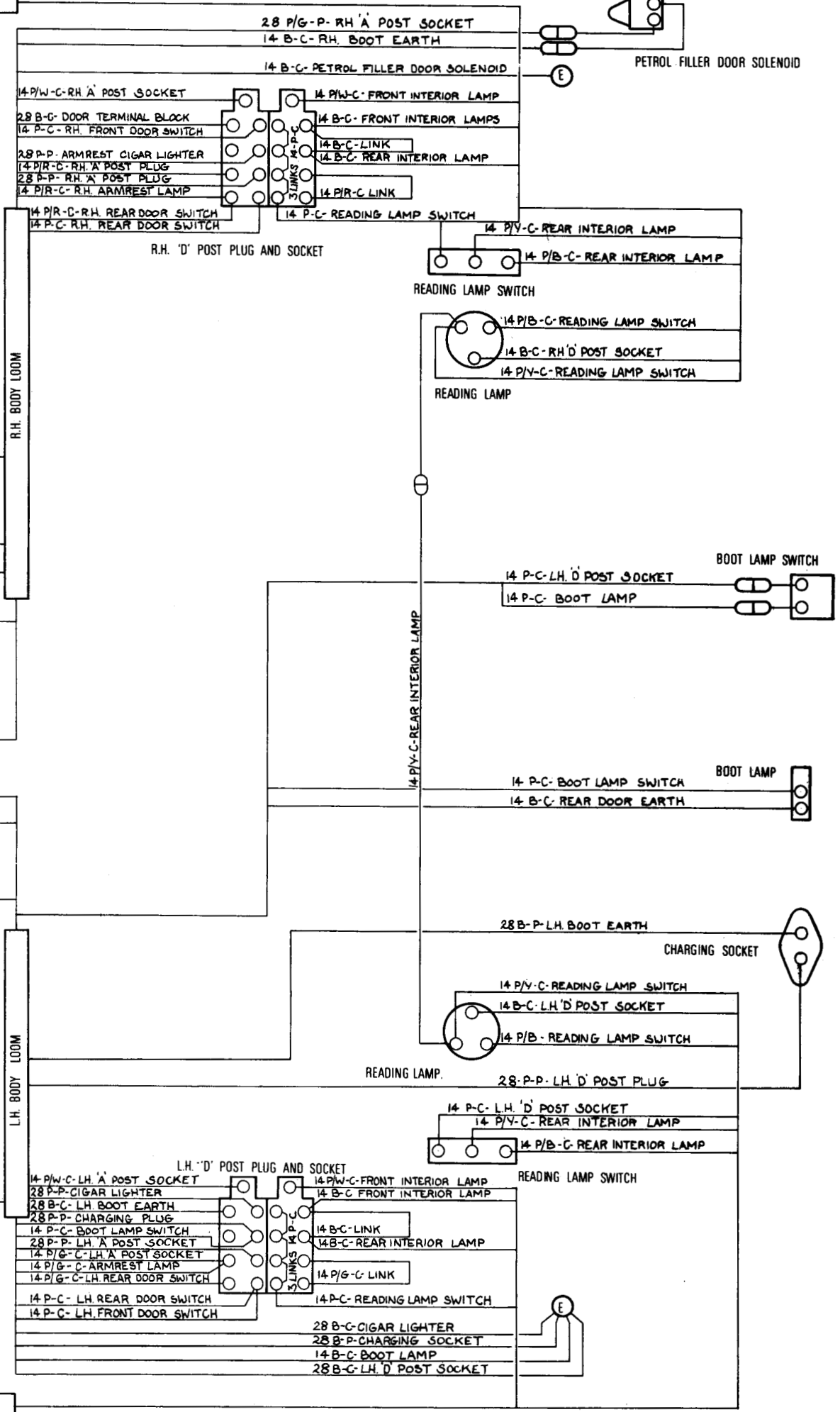

PRACTICAL WIRING DIAGRAM

SHEET 8

GEAR RANGE SELECTOR

**ROLLS-ROYCE SILVER SHADOW
AND
BENTLEY T SERIES
LEFT-HAND DRIVE CARS
PRIOR TO CAR SERIAL NUMBER SRX 6000**

TSD Publication 2571

© Rolls-Royce Limited 1969

Rolls-Royce policy is one of continuous engineering improvement and the right is reserved to revise the contents of this publication without prior notice.

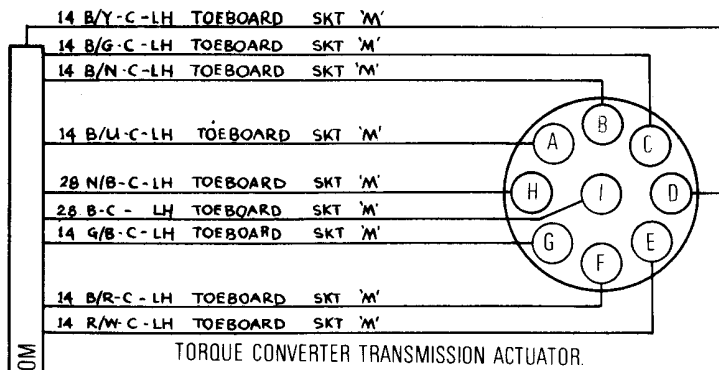

TORQUE CONVERTER TRANSMISSION ACTUATOR LOOM

GEAR SELECTOR LOOM

- 14 B/W-C-LH TOE
- 14 B/G-C-LH TOE
- 14 B/Y-C-LH TOE
- 28 N/B-C-FUSEBO
- 14 B/U-C-LH TOE
- 14 B/R-C-LH TOE
- 14 B/N-C-LH TOE

- 28 N/B-C LH TOE
- 28 N/B-C GI/A

L.H. TOEBOARD PLUG AND SOCKET

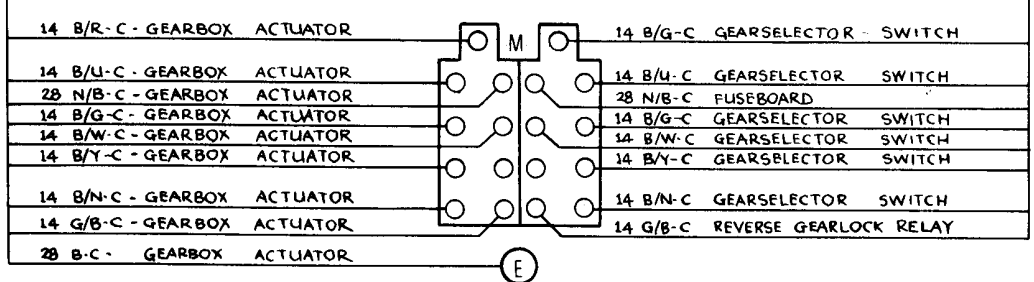

L.H. VALANCE EARTH POINT

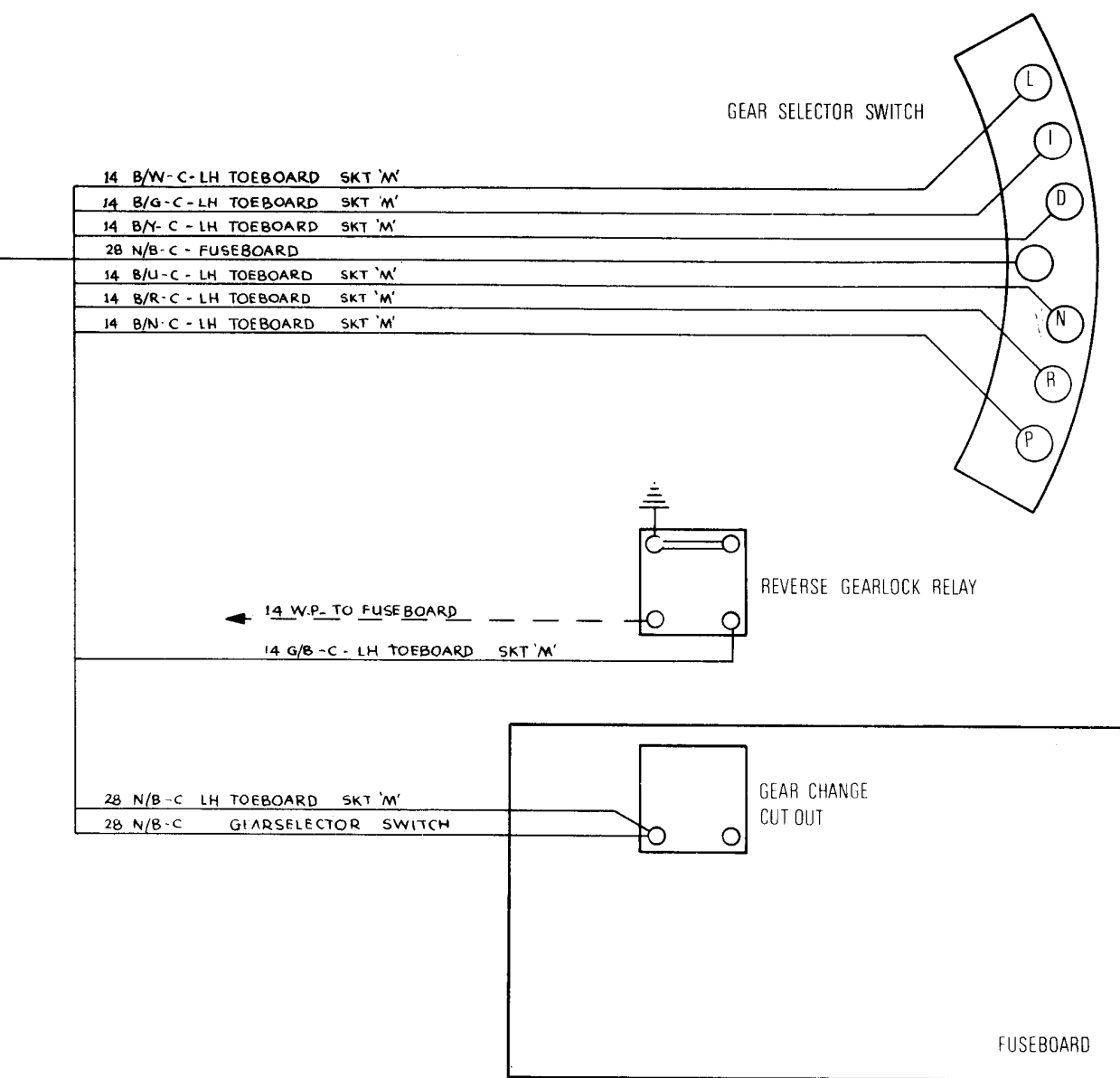

R - SWITCH
R SWITCH
R SWITCH
R SWITCH
R SWITCH
R SWITCH
R SWITCH
LOCK RELAY

KEY TO DIAGRAM

CABLE COLOUR CODE

B = BLACK	P = PURPLE	U = BLUE
G = GREEN	R = RED	W = WHITE
N = BROWN	S = SLATE	Y = YELLOW

CABLE SIZE

14 = 14/.010	28 = 28/.012	120 = 120/.012
44 = 44/.012	65 = 65/.012	

CABLE TYPE

'C' DENOTES COTTON COVERED CABLE
'P' DENOTES PLASTIC COVERED CABLE

EXAMPLE

PRACTICAL WIRING DIAGRAM

SHEET 9

RADIO RECEIVER AND SPEAKERS

ROLLS-ROYCE SILVER SHADOW

AND

BENTLEY T SERIES

LEFT-HAND DRIVE CARS

PRIOR TO CAR SERIAL NUMBER SRX 6000

TSD Publication 2571

© Rolls-Royce Limited 1969

Rolls-Royce policy is one of continuous engineering improvement and the right is reserved to revise the contents of this publication without prior notice.

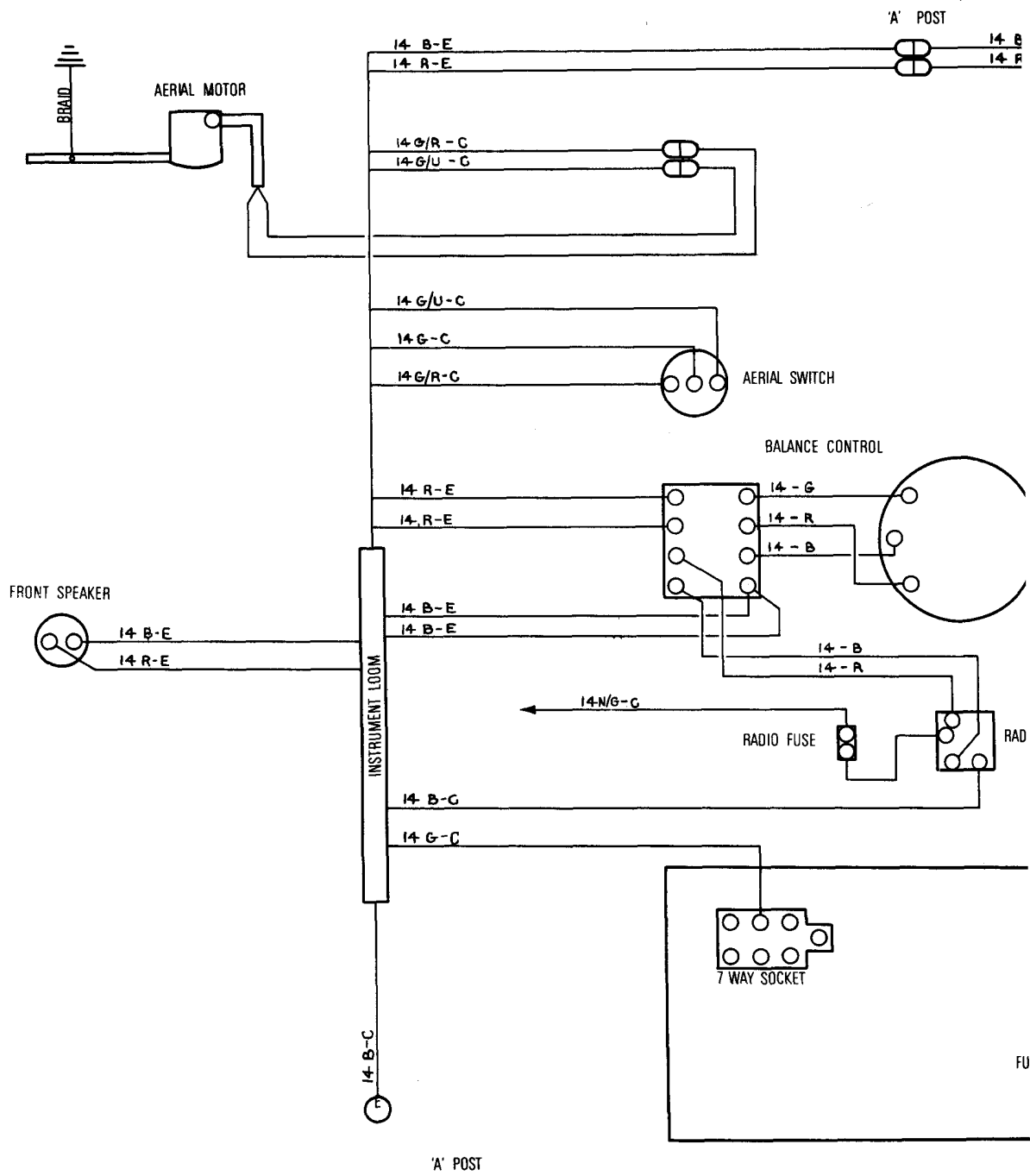

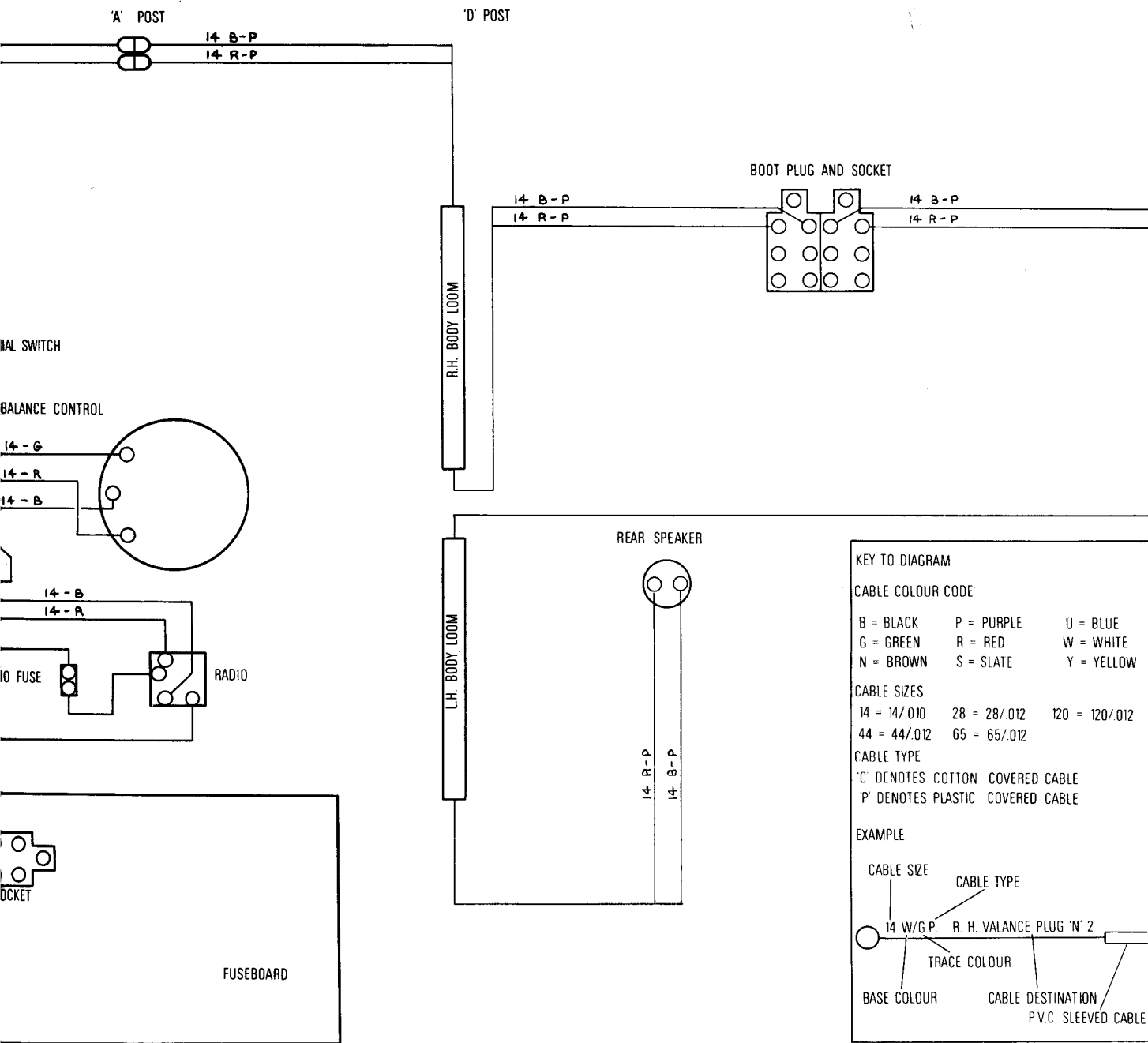

'D' POST

PRACTICAL WIRING DIAGRAM

SHEET 10

DIRECTION INDICATORS & HAND BRAKE WARNING LAMP

ROLLS-ROYCE SILVER SHADOW

AND

BENTLEY T SERIES

LEFT-HAND DRIVE CARS

PRIOR TO CAR SERIAL NUMBER SRX 6000

TSD Publication 2571

© Rolls-Royce Limited 1969

Rolls-Royce policy is one of continuous engineering improvement and the right is reserved to revise the contents of this publication without prior notice.

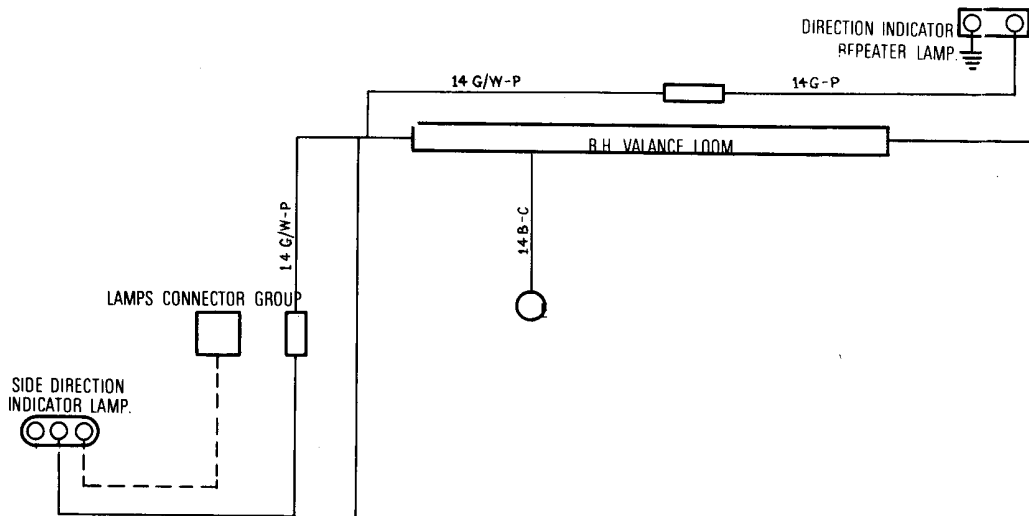

14
14
14
14F
44
44

KEY TO DIAGRAM

CABLE COLOUR CODE

B = BLACK	P = PURPLE	U = BLUE
G = GREEN	R = RED	W = WHITE
N = BROWN	S = SLATE	Y = YELLOW

CABLE SIZE

14 = 14/.010	28 = 28/.012	120 = 120/.012
44 = 44/.012	65 = 65/.012	

'C' DENOTES COTTON COVERED CABLE
'P' DENOTES PLASTIC COVERED CABLE

EXAMPLE

CABLE SIZES CABLE TYPE

14 W/G.P. - R.H. VALANCE PLUG 'N' 2

TRACE COLOUR CABLE DESTINATION

BASE COLOUR P.V.C. SLEEVED CABLE

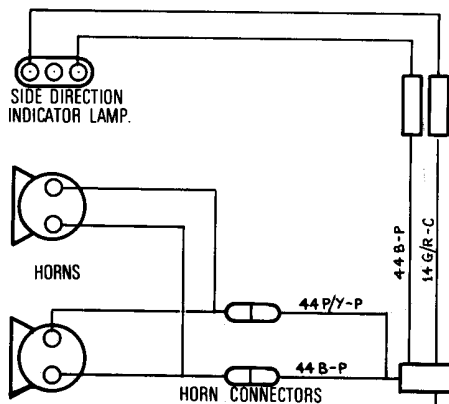
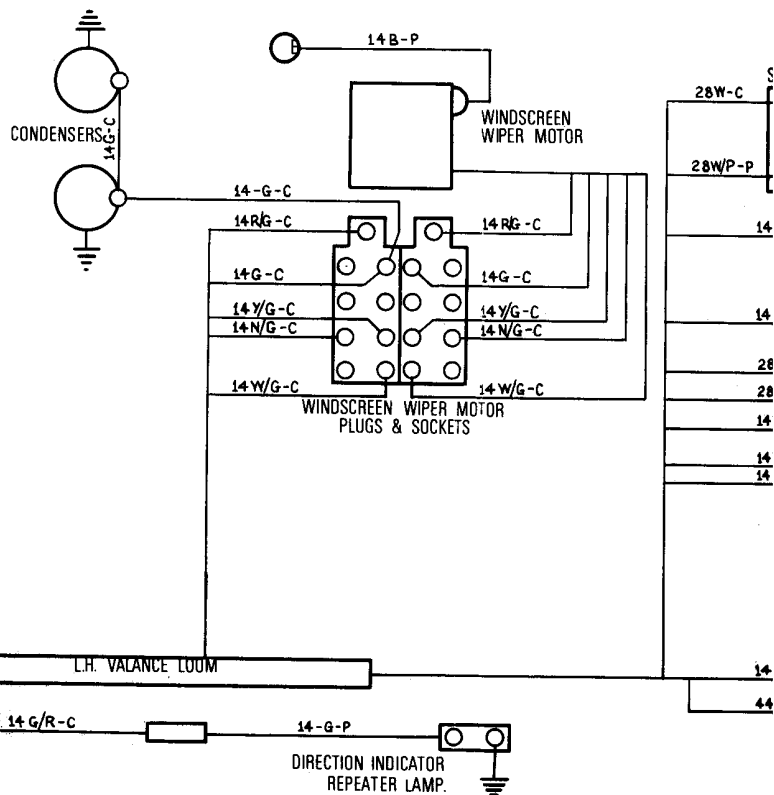
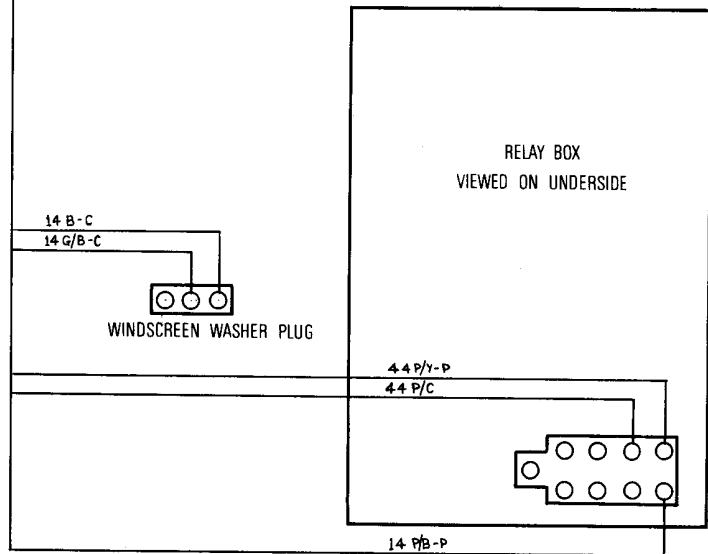

28W-C
28W/P-P
14
14
28
28
14
14
14
14
14
44

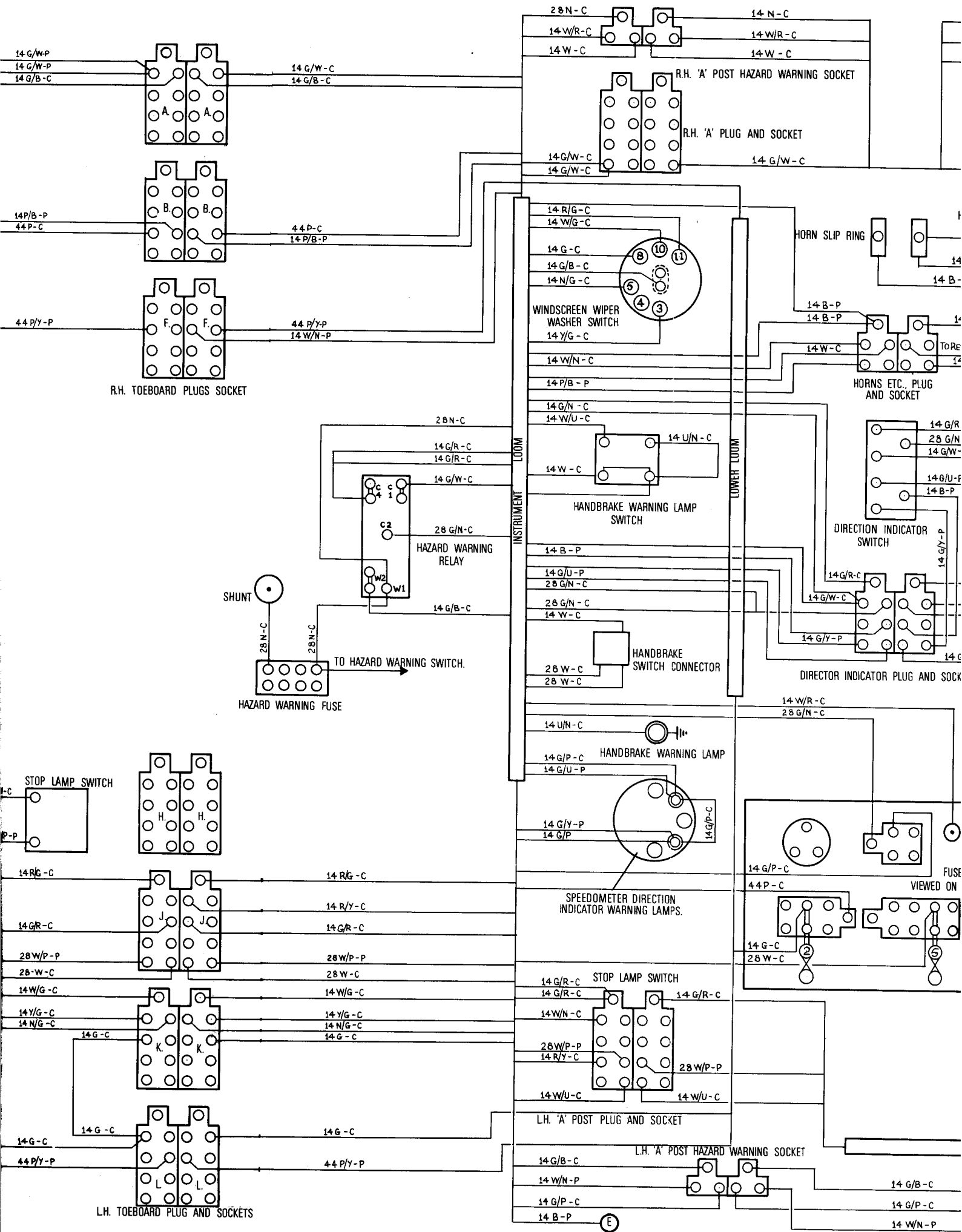

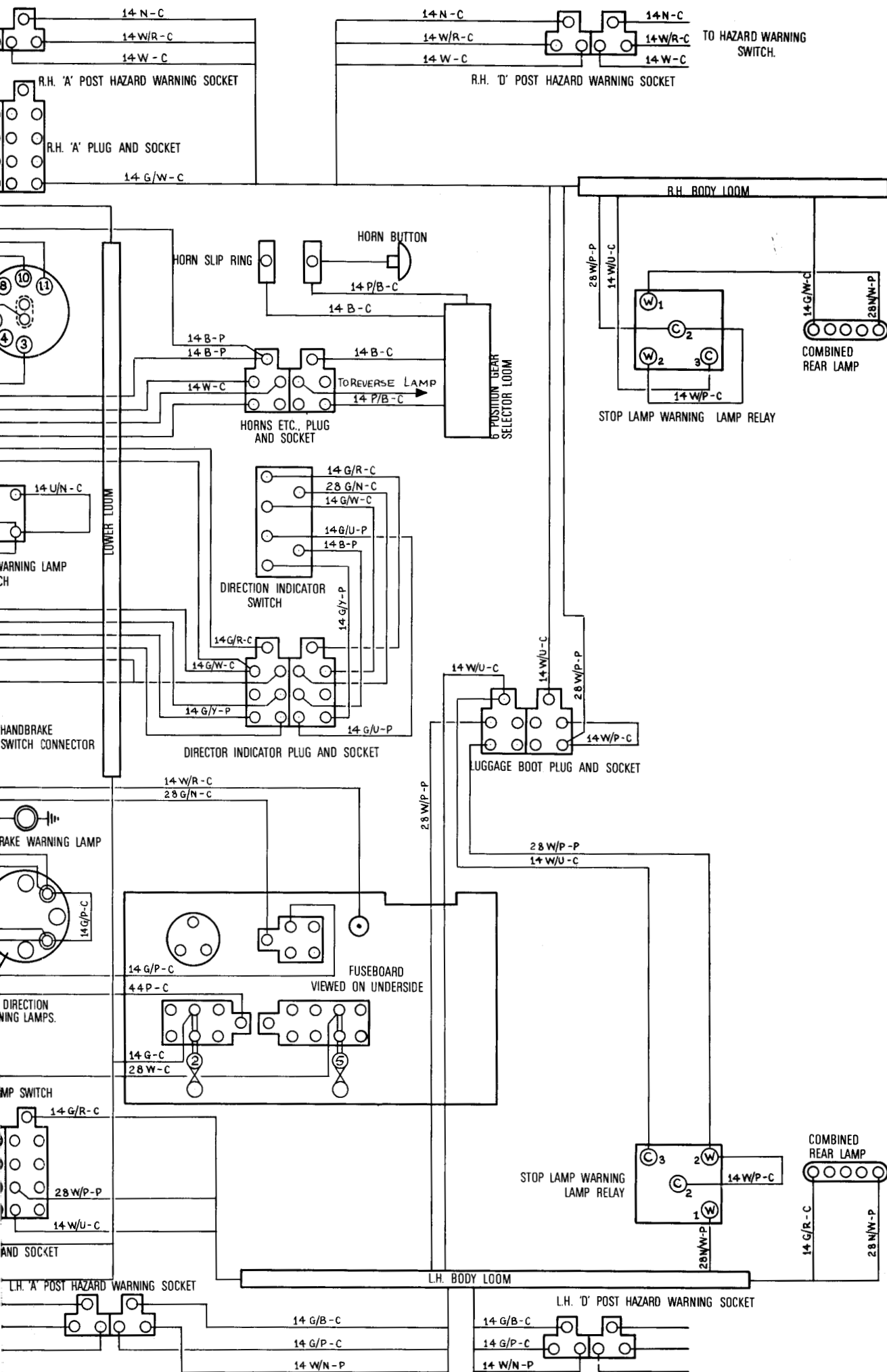

Section 8

RIGHT-HAND DRIVE LONG WHEELBASE CARS WITH DIVISION, FROM SERIAL NUMBER 6598

APPLICATION	SHEET No
Engines Looms, L.H. and R.H. Valance Looms and Gearchange Actuator Loom	1
L.H. and R.H. Body Looms, Door Looms and Refrigeration Looms	2
Main Distribution Loom, Air Conditioning Loom, Secondary Distribution Loom, Console Loom and Instrument Loom	3

PRACTICAL WIRING DIAGRAM

SHEET 1

ENGINE LOOM , L.H. & R.H. VALANCE LOOMS AND GEARCHANGE

ACTUATOR LOOM

ROLLS-ROYCE SILVER SHADOW

AND

BENTLEY T SERIES

RIGHT-HAND DRIVE LONG WHEELBASE CARS

WITH DIVISION

AFTER CAR SERIAL NUMBER 6598

T.S.D. Publications 2664

© Rolls-Royce Limited 1970

Rolls-Royce policy is one of continuous engineering improvement and the right is reserved to revise the contents of this publication without prior notice.

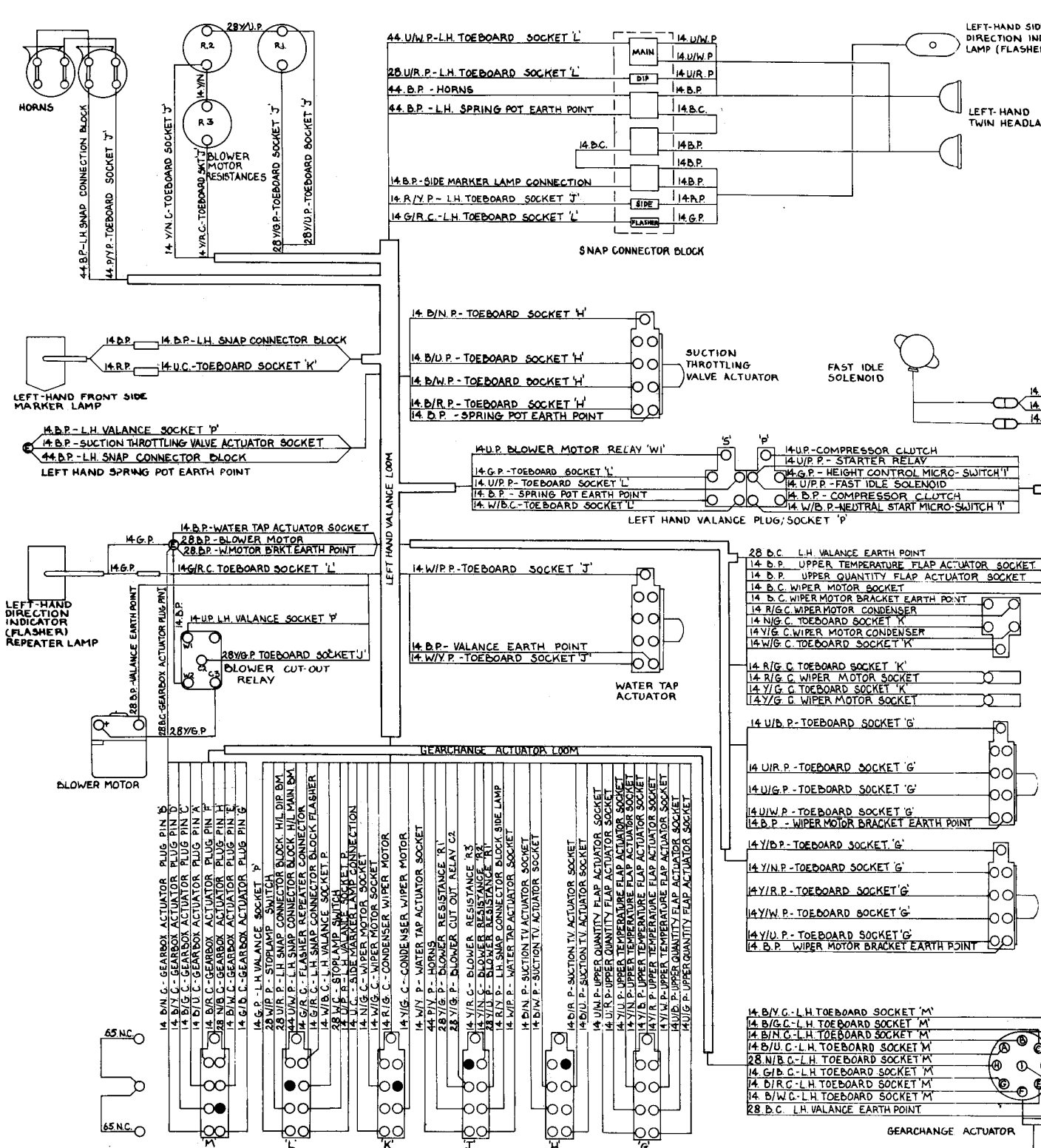

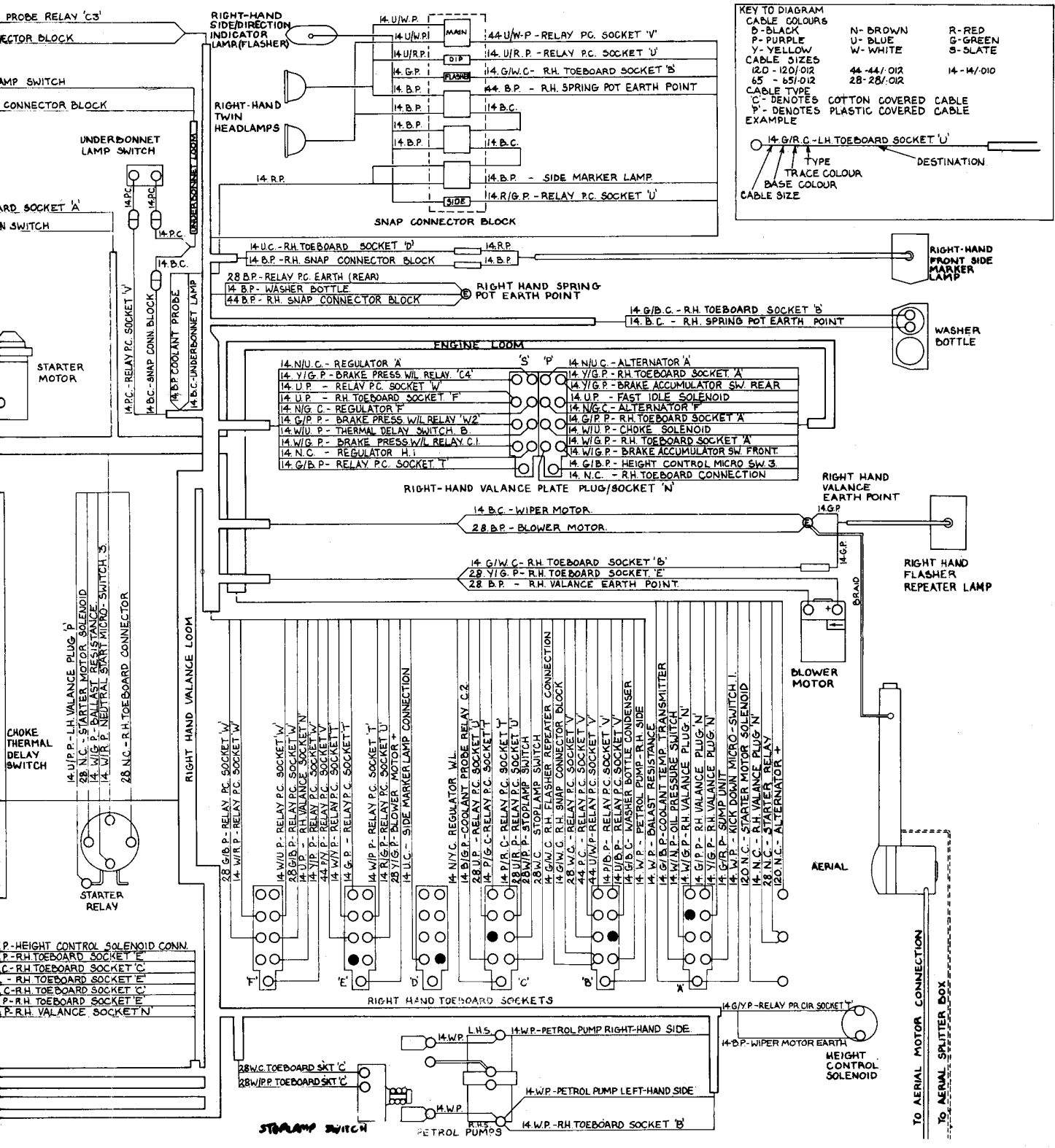

PRACTICAL WIRING DIAGRAM

SHEET 2

L.H. & R.H. BODY LOOMS, DOOR LOOMS, DIVISION TO BOOT
REFRIGERATION UNIT AND BOOT REFRIGERATION UNIT
ROLLS-ROYCE SILVER SHADOW

AND

BENTLEY T SERIES

RIGHT-HAND DRIVE LONG WHEELBASE CARS
WITH DIVISION

AFTER CAR SERIAL NUMBER 6598

T.S.D. Publications 2664

© Rolls-Royce Limited 1970

Rolls-Royce policy is one of continuous engineering
improvement and the right is reserved to revise the
contents of this publication without prior notice.

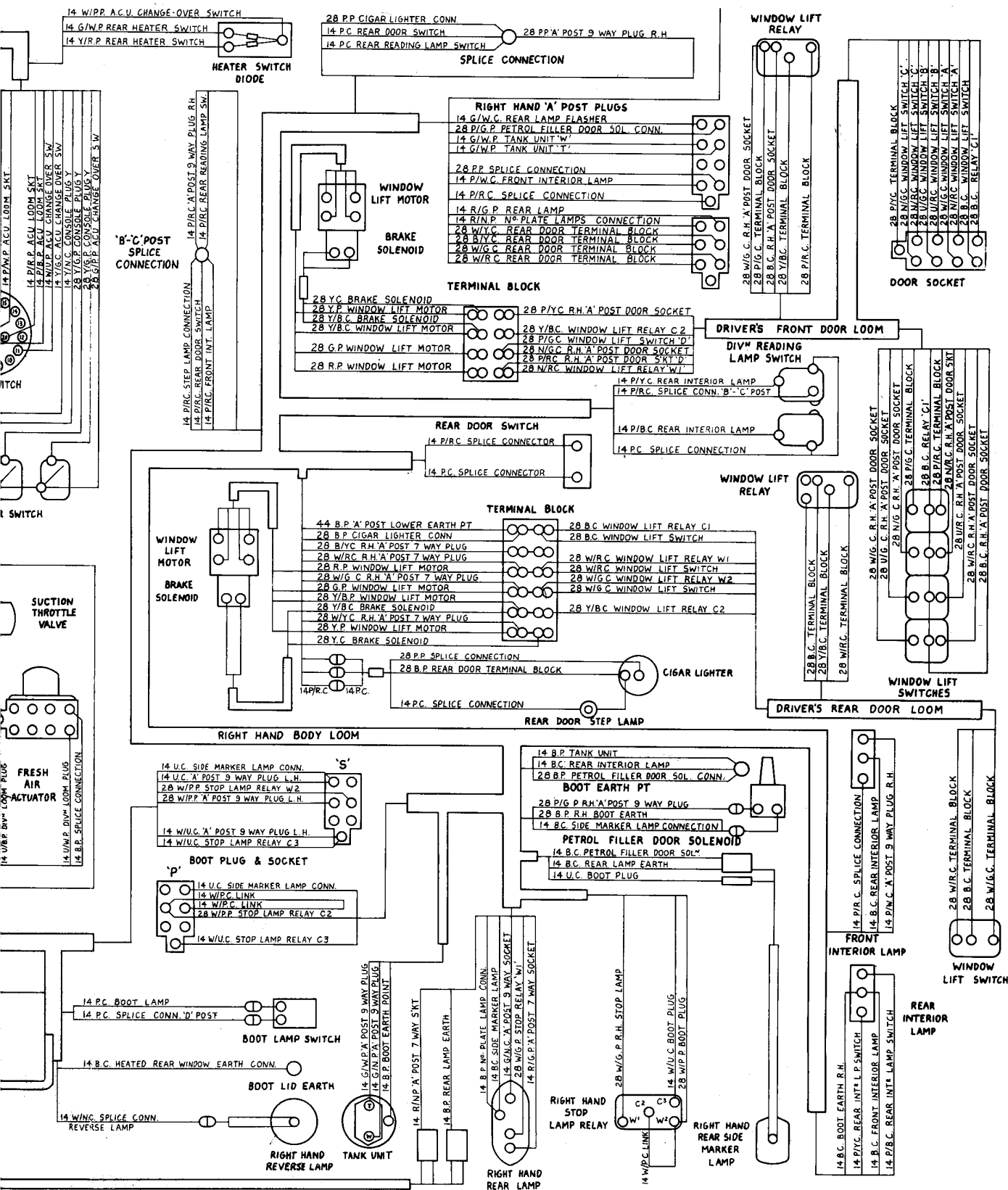

PRACTICAL WIRING DIAGRAM

SHEET 3

MAIN DISTRIBUTION LOOM, AIR CONDITIONING LOOM, SECONDARY
DISTRIBUTION LOOM, CONSOLE LOOM AND INSTRUMENT LOOM

ROLLS-ROYCE SILVER SHADOW

AND

BENTLEY T SERIES

RIGHT-HAND DRIVE LONG WHEELBASE CARS

WITH DIVISION

AFTER CAR SERIAL NUMBER 6598

T.S.D. Publications 2664

© Rolls-Royce Limited 1970

**Rolls-Royce policy is one of continuous engineering
improvement and the right is reserved to revise the
contents of this publication without prior notice.**

SECONDARY DISTRIBUTION LOOM

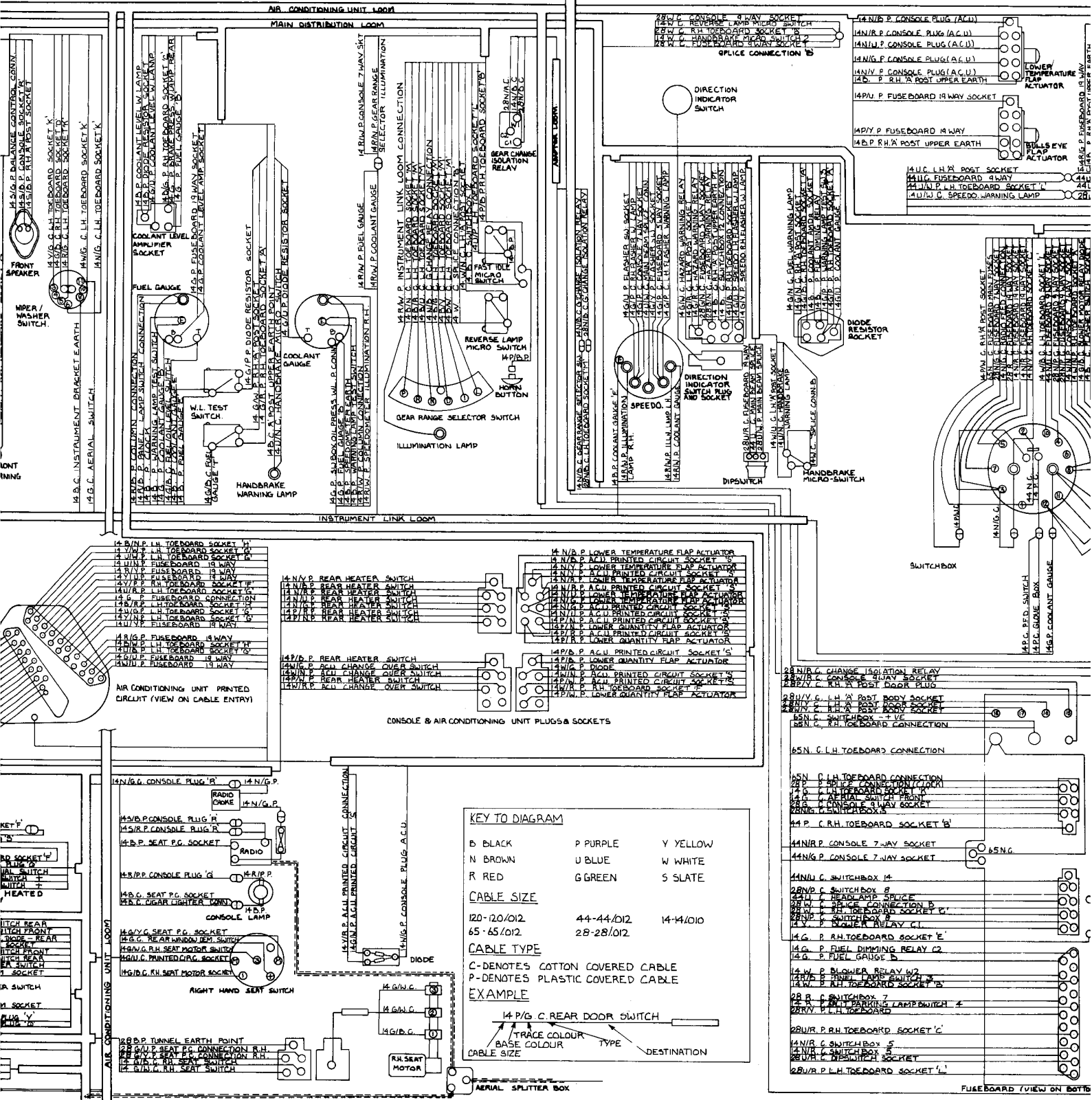

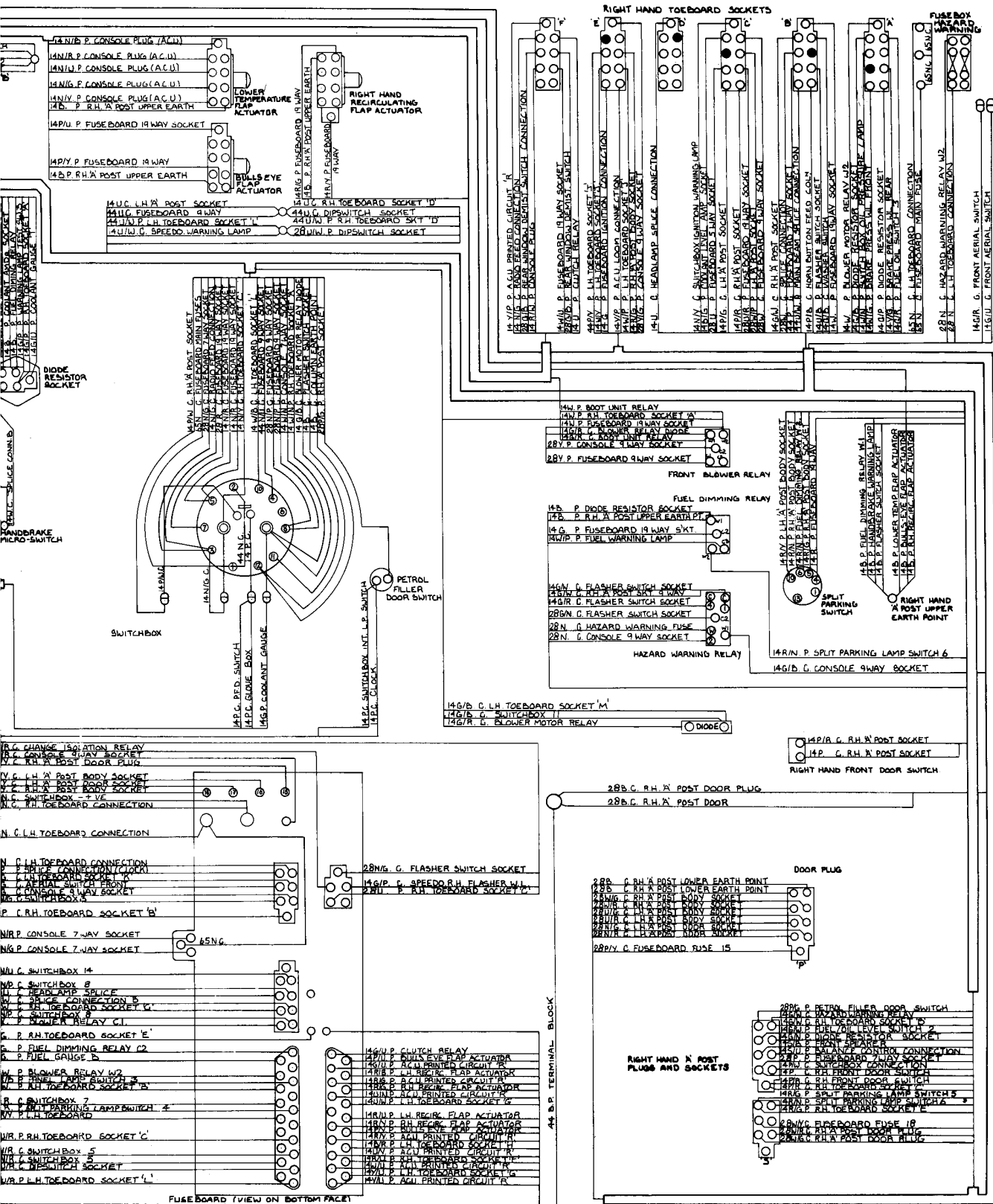

Section 9

RIGHT-HAND DRIVE CARS FROM SERIAL NUMBER 9000

APPLICATION	SHEET No.
Engine Compartment Looms	1
Interior Looms	2
Left-hand and Right-hand Body Looms, Console and Door Looms	3
Fuseboard and Sockets	4

Printed in England

April 1971

T.S.D. 2476

PRACTICAL WIRING DIAGRAMS

Sheet 1
Engine Compartment Looms

for
Rolls-Royce Silver Shadow
and
Bentley T Series

**RIGHT-HAND DRIVE CARS FROM
SERIAL NUMBER 9000**

T. S. D. Publications 2723

© Rolls-Royce Limited 1970.

"This document is the property of Rolls-Royce Limited and may not be copied or communicated to a third party or used for any purpose other than that for which it is supplied without the express written authority of Rolls-Royce Limited."

"Whilst the information in this document given in good faith based upon the latest knowledge available to Rolls-Royce Limited, Rolls-Royce Limited gives no warranty or representation concerning such information, and such information must not be taken as establishing any contractual or other commitment on the part of Rolls-Royce Limited."

PRACTICAL WIRING DIAGRAMS

Sheet 2
Interior Looms

for
Rolls-Royce Silver Shadow
and
Bentley T Series

**RIGHT-HAND DRIVE CARS FROM
SERIAL NUMBER 9000**

T. S. D. Publications 2723

“© Rolls-Royce Limited 1970”.

“This document is the property of Rolls-Royce Limited and may not be copied or communicated to a third party or used for any purpose other than that for which it is supplied without the express written authority of Rolls-Royce Limited.”

“Whilst the information in this document given in good faith based upon the latest knowledge available to Rolls-Royce Limited, Rolls-Royce Limited gives no warranty or representation concerning such information, and such information must not be taken as establishing any contractual or other commitment on the part of Rolls-Royce Limited.”

PRACTICAL WIRING DIAGRAMS

Sheet 3
Left-hand and Right-hand Body Looms
Console and Door Looms

for
Rolls-Royce Silver Shadow
and
Bentley T Series

RIGHT-HAND DRIVE CARS FROM
SERIAL NUMBER 9000

T. S. D. Publications 2723

© Rolls-Royce Limited 1970.

"This document is the property of Rolls-Royce Limited and may not be copied or communicated to a third party or used for any purpose other than that for which it is supplied without the express written authority of Rolls-Royce Limited."

"Whilst the information in this document given in good faith based upon the latest knowledge available to Rolls-Royce Limited, Rolls-Royce Limited gives no warranty or representation concerning such information, and such information must not be taken as establishing any contractual or other commitment on the part of Rolls-Royce Limited."

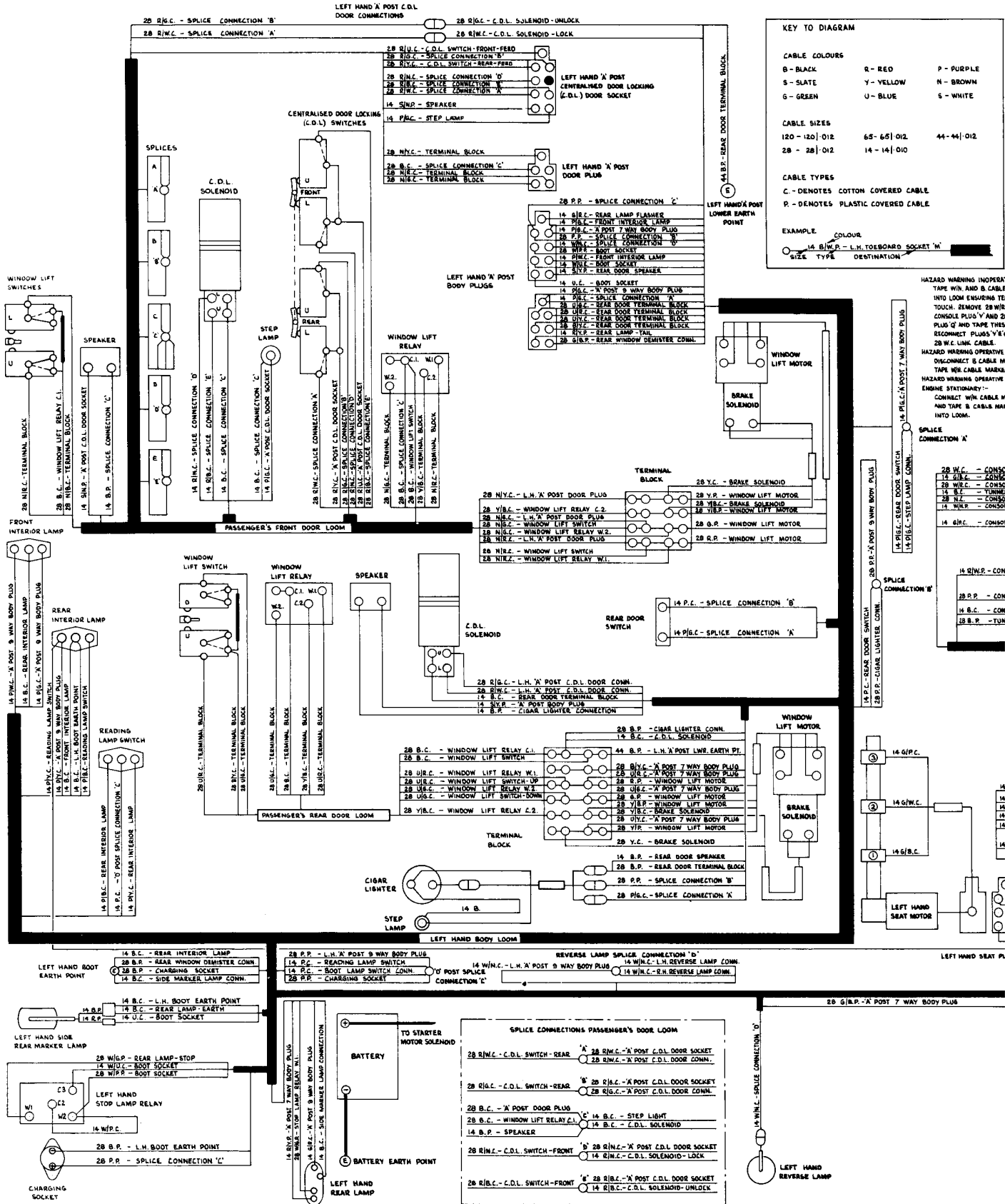

PRACTICAL WIRING DIAGRAMS

Sheet 4
Fuseboard and Sockets

for
Rolls-Royce Silver Shadow
and
Bentley T Series

**RIGHT-HAND DRIVE CARS FROM
SERIAL NUMBER 9000**

T. S. D. Publications 2723

© Rolls-Royce Limited 1970.

"This document is the property of Rolls-Royce Limited and may not be copied or communicated to a third party or used for any purpose other than that for which it is supplied without the express written authority of Rolls-Royce Limited."

"Whilst the information in this document given in good faith based upon the latest knowledge available to Rolls-Royce Limited, Rolls-Royce Limited gives no warranty or representation concerning such information, and such information must not be taken as establishing any contractual or other commitment on the part of Rolls-Royce Limited."

ENGINE LOOM

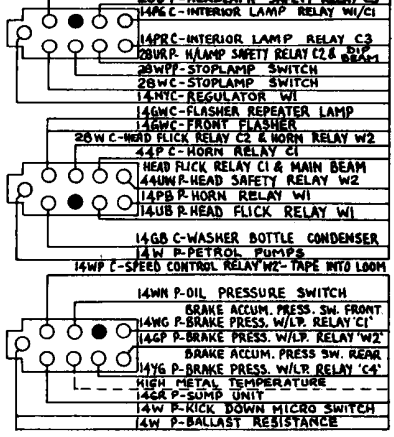

MAIN DISTRIBUTION LOOM

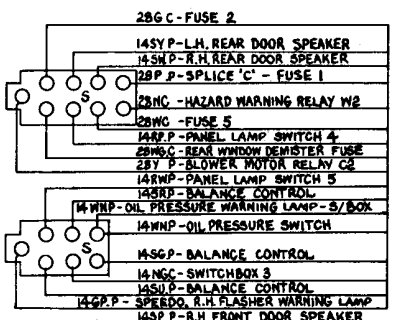

SECONDARY DISTRIBUTION LOOM

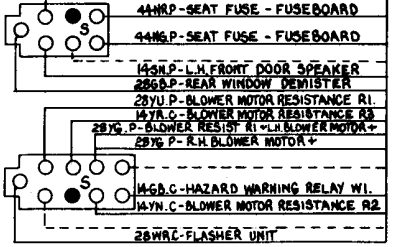

SECONDARY DISTRIBUTION LOOM

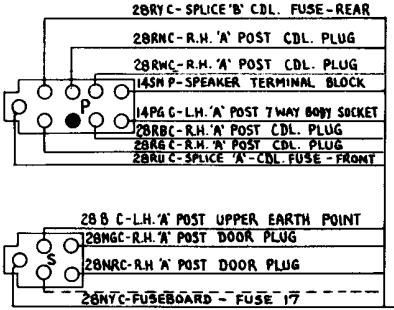

MAIN DISTRIBUTION LOOM

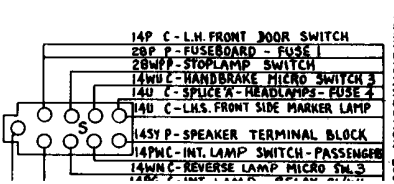

TOEBOARD SOCKET CONNECTIONS

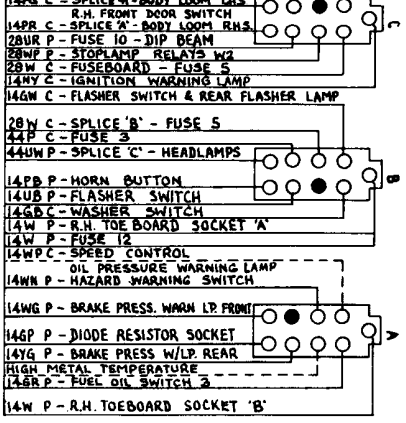

CONSOLE SOCKET CONNECTIONS

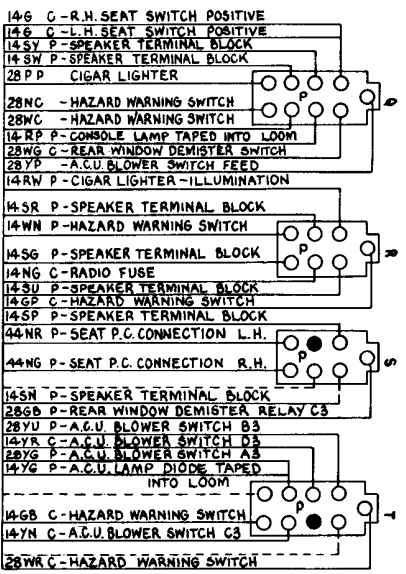

PASSENGERS DOOR LOOM

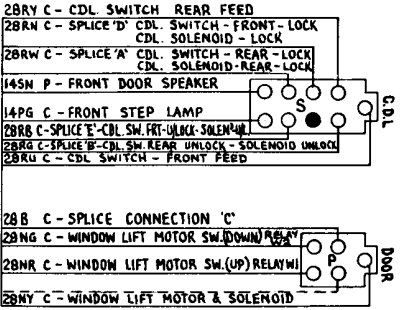

LEFT-HAND

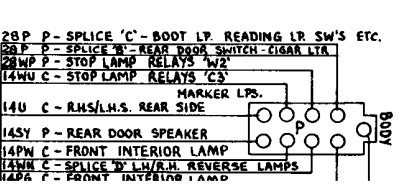

TO ENABLE THE ABOVE CABLE CONNECTIONS TO BE EASILY FOLLOWED THE CHARTS SHOW THE ACTUAL ORIGIN AND DESTINATION OF EACH CABLE BUT DO NOT TAKE INTO ACCOUNT THE RUN OF THE CABLE WITHIN THE LOOMS. TO OBTAIN THIS INFORMATION SEE THE PRACTICAL WIRING DIAGRAM ON SHEETS 1,2,3.

PASSENGERS SIDE FRONT REAR

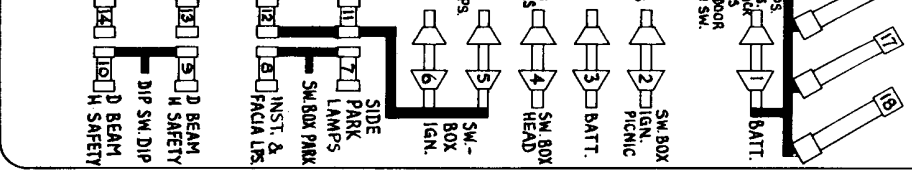
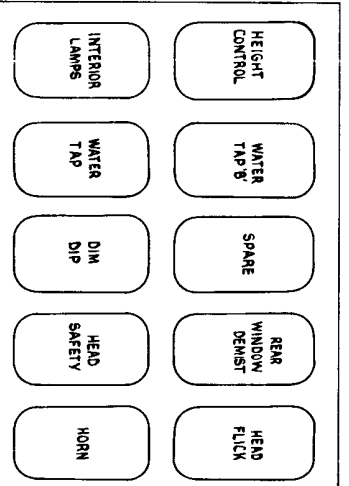
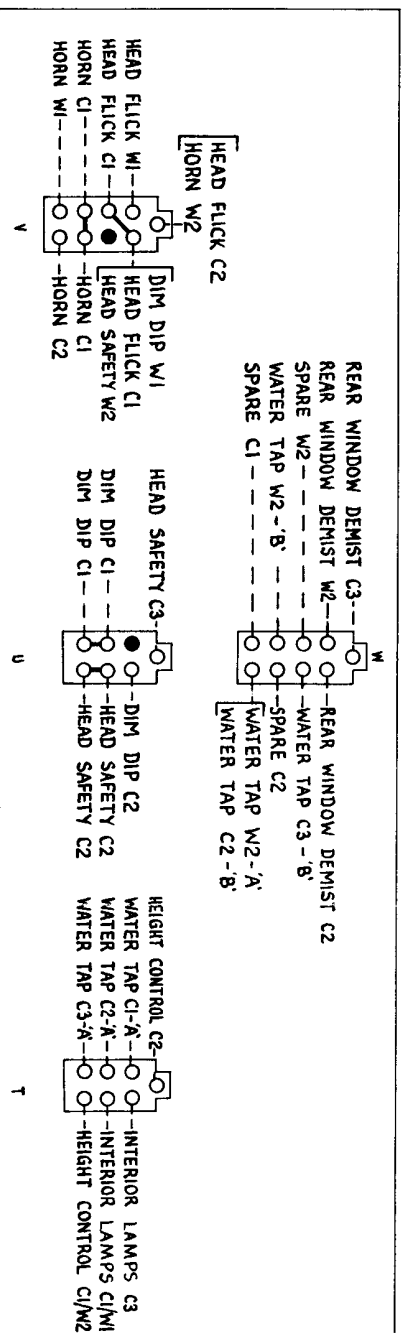

Table with 3 columns: CABLE, FROM, TO. Lists various cables like 14BHP, 14BUP, 14BOP, 14BYV, 14BWP, 14GBB, 14BP, 14YBP, 14WBP, 14GP and their corresponding terminals and actuators.

GEARCHANGE ACTUATOR SOCKET TO ACTUATOR TERMINAL CONNECTIONS



RELAY BOARD PRINTED CIRCUIT - POSITION OF RELAYS VIEWED ON RELAY FACE OF PRINTED CIRCUIT



W/TERMINAL ON HEAD SAFETY, BOTH WATER TAP, HT. CONTROL, SPARE AND REAR WINDOW DEMIST. RELAYS EARTHED AS IS W/ ON INTERIOR LAMPS RELAY RELAY BOARD PRINTED CIRCUIT - RELAYS TO SOCKET CONNECTIONS - VIEWED ON SOCKET FACE OF PRINTED CIRCUIT

Section 10

LEFT-HAND DRIVE CARS FROM SERIAL NUMBER 9000

APPLICATION	SHEET No.
Engine Compartment Looms	1
Main and Secondary Distribution Looms, and Air Conditioning Looms	2
Left-hand and Right-hand Body Looms	3
Fuseboard and Sockets	4

Printed in England

April 1971

T.S.D. 2476

PRACTICAL WIRING DIAGRAMS

Sheet 1
Engine Compartment Looms

for
Rolls-Royce Silver Shadow
and
Bentley T Series

**LEFT-HAND DRIVE CARS FROM
SERIAL NUMBER 9000**

T.S.D. Publications 2724

© Rolls-Royce Limited 1970.

"This document is the property of Rolls-Royce Limited and may not be copied or communicated to a third party or used for any purpose other than that for which it is supplied without the express written authority of Rolls-Royce Limited."

"Whilst the information in this document given in good faith based upon the latest knowledge available to Rolls-Royce Limited, Rolls-Royce Limited gives no warranty or representation concerning such information, and such information must not be taken as establishing any contractual or other commitment on the part of Rolls-Royce Limited."

KEY TO DIAGRAM

CABLE COLOURS
 B - BLACK R - RED P - PURPLE
 S - SLATE Y - YELLOW N - BROWN
 G - GREEN U - BLUE W - WHITE

CABLE SIZES
 120-120/012 65-65/012 44-44/012
 28-28/012 14-14/010

C - DENOTES COTTON COVERED CABLE.
 P - DENOTES PLASTIC COVERED CABLE.

CABLE COLOUR
 14 BM.P - L.H. TOEBOARD SOCKET M
 CABLE SIZE CABLE TYPE DESTINATION

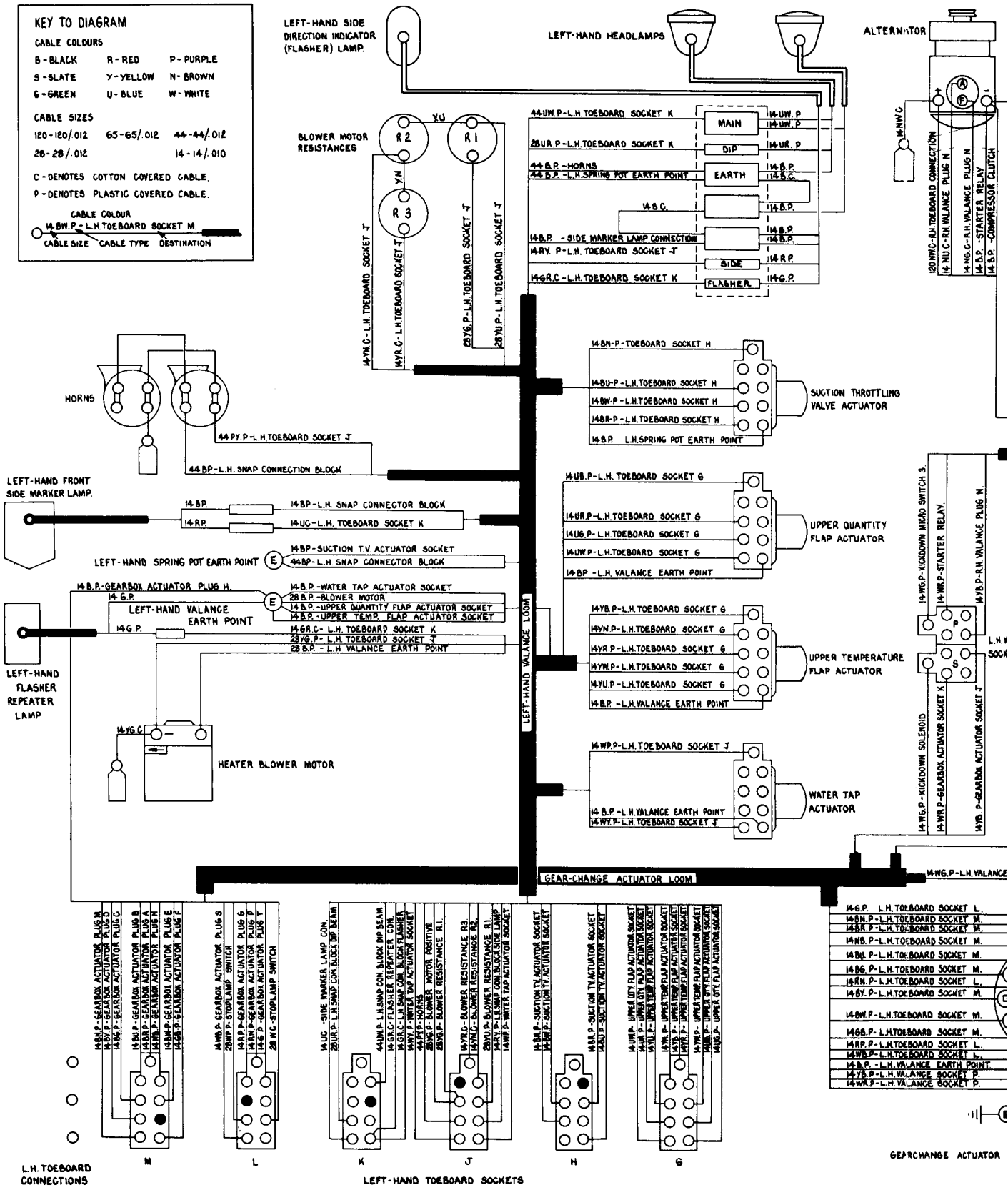

L.H. TOEBOARD CONNECTIONS

LEFT-HAND TOEBOARD SOCKETS

GEAR-CHANGE ACTUATOR

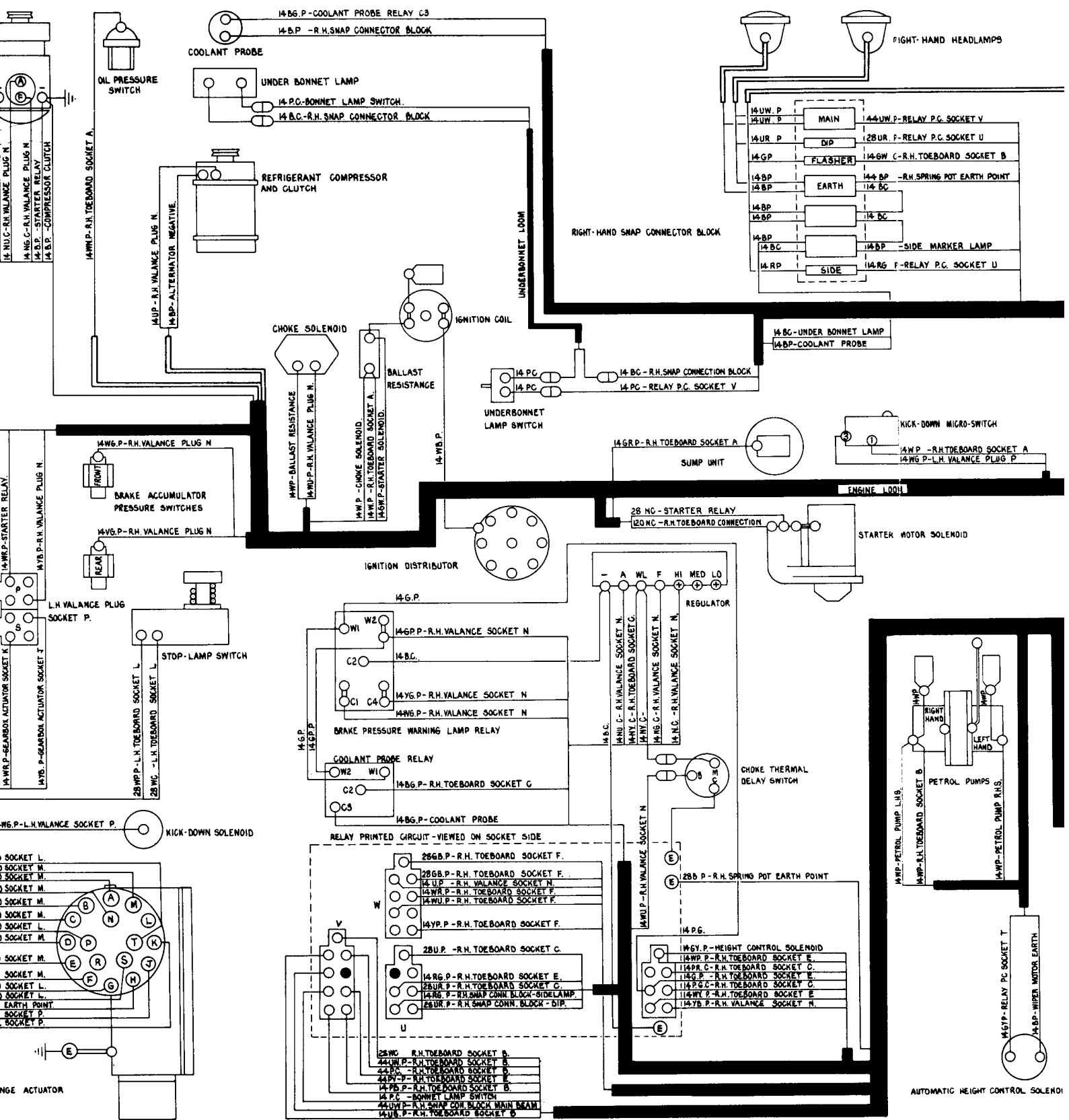

PRACTICAL WIRING DIAGRAMS

Sheet 2
Main and Secondary Distribution Looms
Air Conditioning Unit Looms

for
Rolls-Royce Silver Shadow
and
Bentley T Series

LEFT-HAND DRIVE CARS FROM
SERIAL NUMBER 9000

T.S.D. Publications 2724

© Rolls-Royce Limited 1970.

"This document is the property of Rolls-Royce Limited and may not be copied or communicated to a third party or used for any purpose other than that for which it is supplied without the express written authority of Rolls-Royce Limited."

"Whilst the information in this document given in good faith based upon the latest knowledge available to Rolls-Royce Limited, Rolls-Royce Limited gives no warranty or representation concerning such information, and such information must not be taken as establishing any contractual or other commitment on the part of Rolls-Royce Limited."

