

THEORETICAL WIRING DIAGRAM

Sheet 10

For
Rolls-Royce Silver Shadow
and
Bentley T Series

**LEFT-HAND DRIVE SALOON AND LONG
WHEEL BASE NON-DIVISION CARS FOR
COUNTRIES OTHER THAN USA AND
CANADA FROM CAR SERIAL NUMBER
13754**

T.S.D. Publication 2969

"© Rolls-Royce Motors Limited 1973"

"This document is the property of Rolls-Royce Motors Limited and may not be copied or communicated to a third party or used for any purpose other than that for which it is supplied without the express written authority of Rolls-Royce Motors Limited."

"Whilst the information in this document given in good faith based upon the latest knowledge available to Rolls-Royce Motors Limited. Rolls-Royce Motors Limited gives no warranty or representation concerning such information, and such information must not be taken as establishing any contractual or other commitment on the part of Rolls-Royce Motors Limited."

ELECTRICALLY OPERATED SEATS

ELECTRIC WINDOW LIFTS WITH P.M. MOTORS

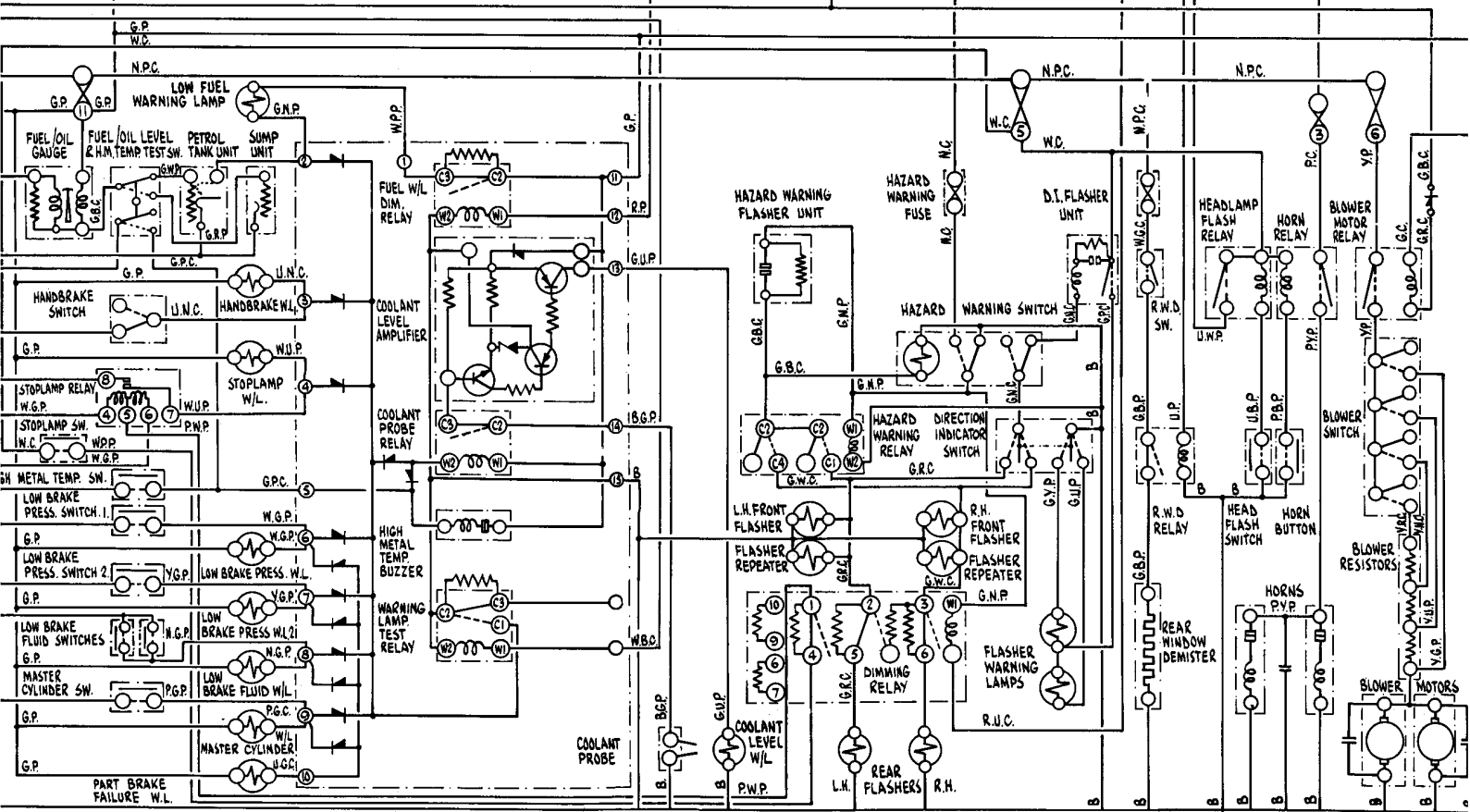
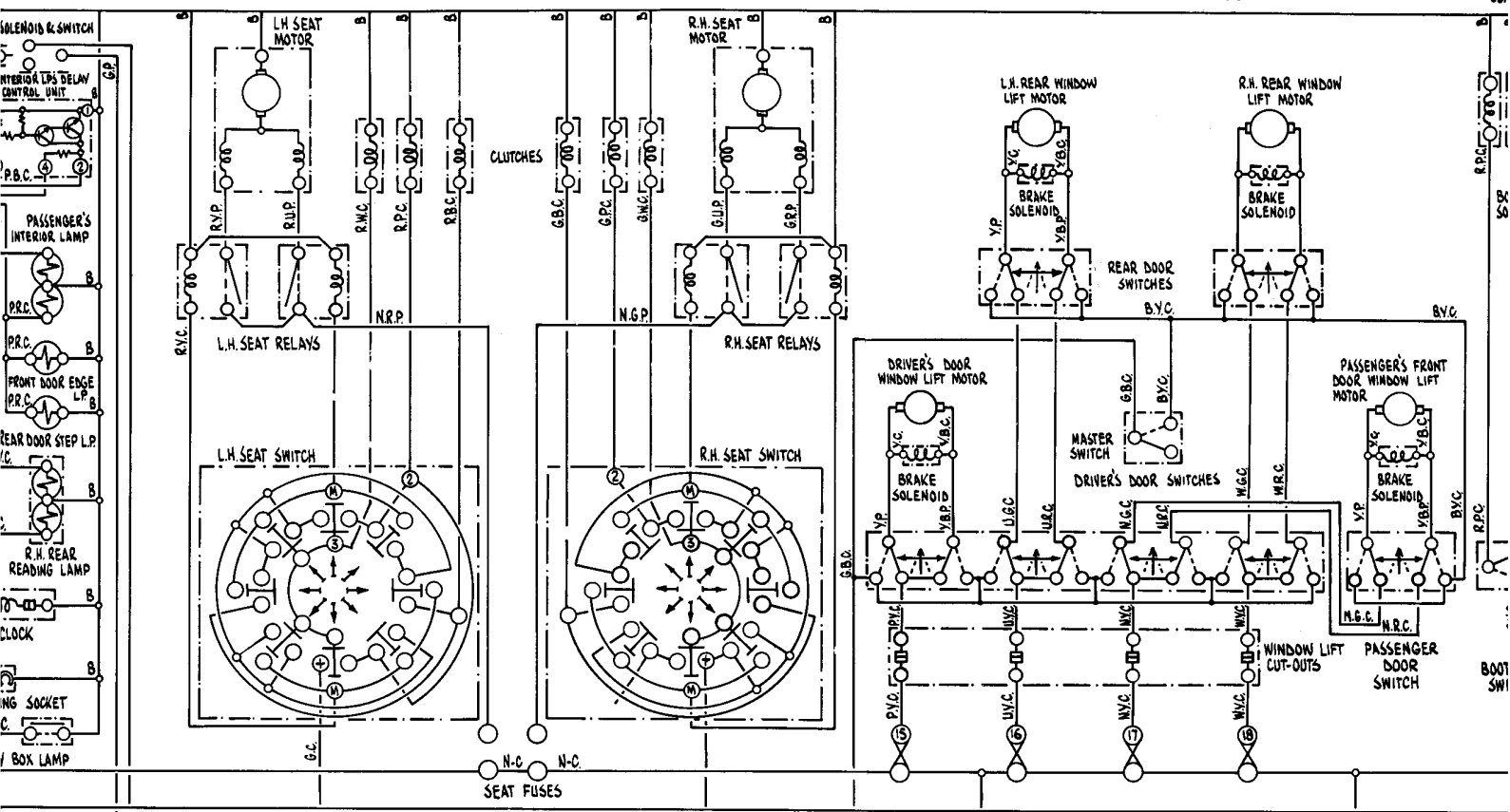

STOPLAMPS, WARNING LAMPS, FUEL GAUGE. HIGH METAL TEMPERATURE BUZZER, COOLANT PROBE.

DIRECTION INDICATORS, HAZARD WARNING

REAR WINDOW DEMISTER

HORNS

BLOWER MOTORS

ALISED DOOR & BOOT LID LOCKING

HEADLAMPS

SIDELAMPS

PANEL LAMPS

AIR CONDITIONING SYSTEM

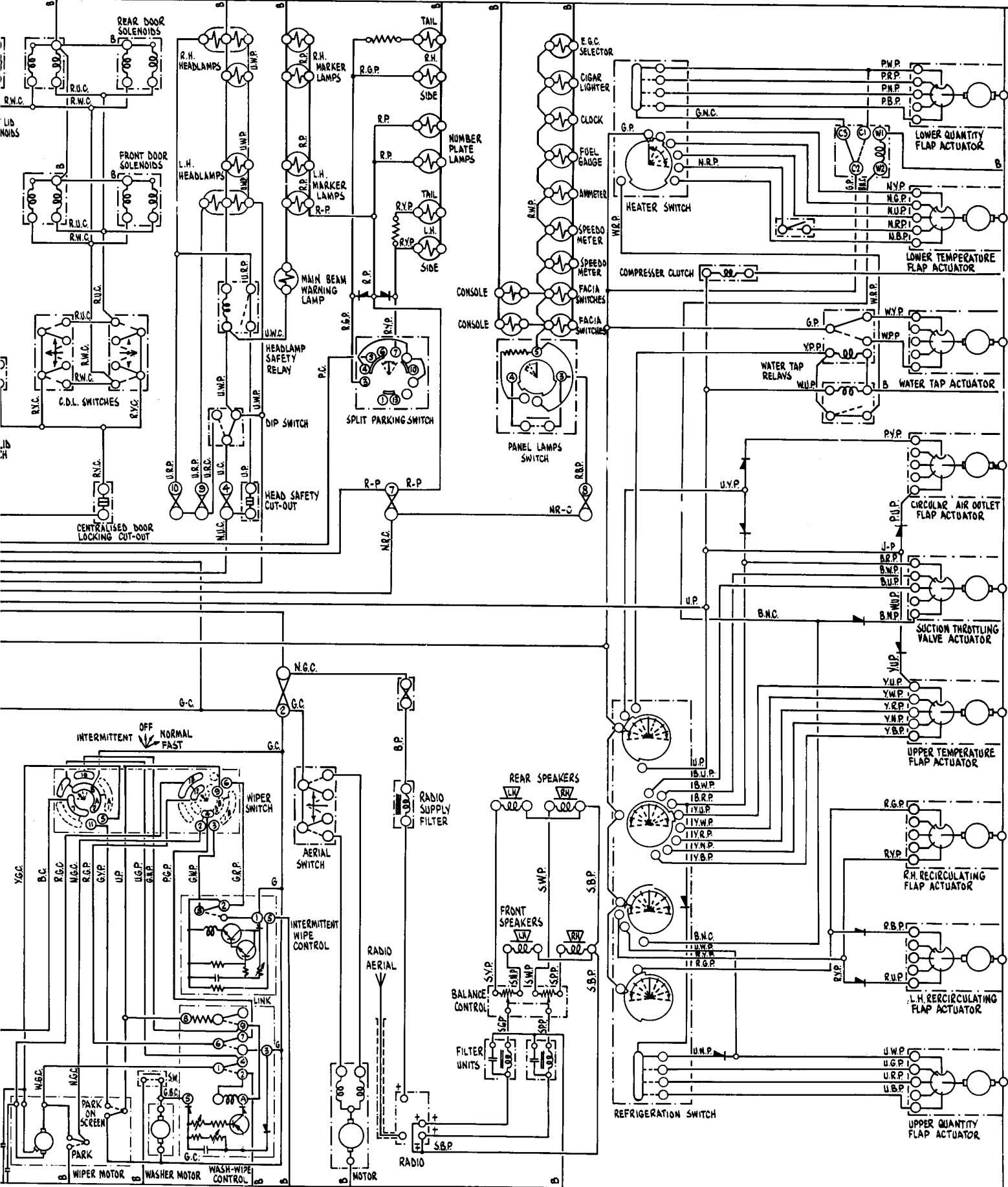

WINDSCREEN WIPER (INCLUDING INTERMITTENT OPERATION) AND WASHER

AERIAL

STEREO RADIO
† DENOTES RADIO FLYING LEAD

THEORETICAL WIRING DIAGRAM

Sheet 11

**For
Rolls-Royce Silver Shadow
and
Bentley T Series**

**SALOON AND LONG WHEEL BASE
DIVISION CARS FOR USA AND CANADA
FROM CAR SERIAL NUMBER 13754**

T.S.D. Publication 2968

"© Rolls-Royce Motors Limited 1973"

"This document is the property of Rolls-Royce Motors Limited and may not be copied or communicated to a third party or used for any purpose other than that for which it is supplied without the express written authority of Rolls-Royce Motors Limited."

"Whilst the information in this document given in good faith based upon the latest knowledge available to Rolls-Royce Motors Limited. Rolls-Royce Motors Limited gives no warranty or representation concerning such information, and such information must not be taken as establishing any contractual or other commitment on the part of Rolls-Royce Motors Limited."

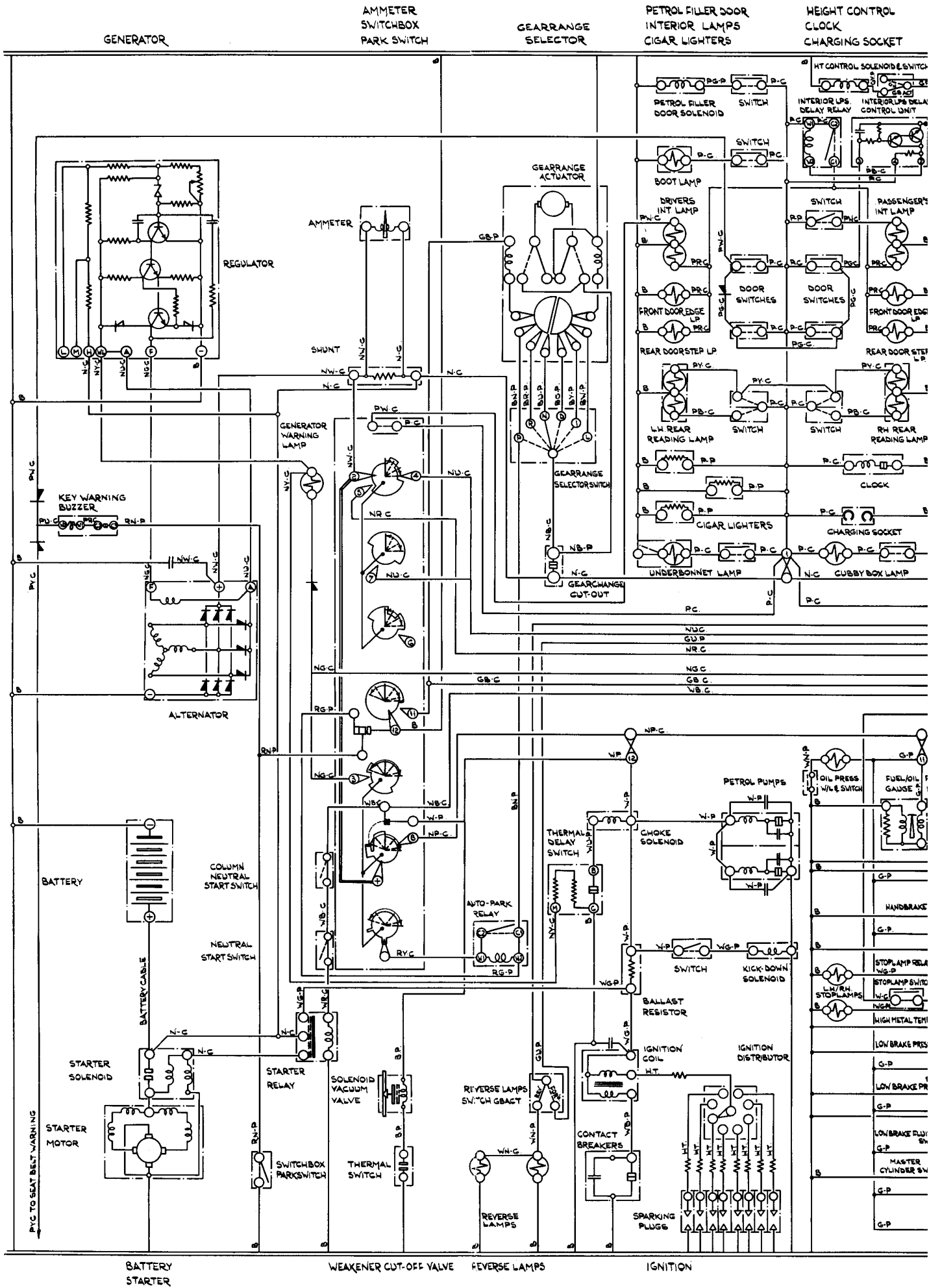

ELECTRICALLY OPERATED SEATS

ELECTRIC WINDOW LIFTS WITH P.M. MOTORS

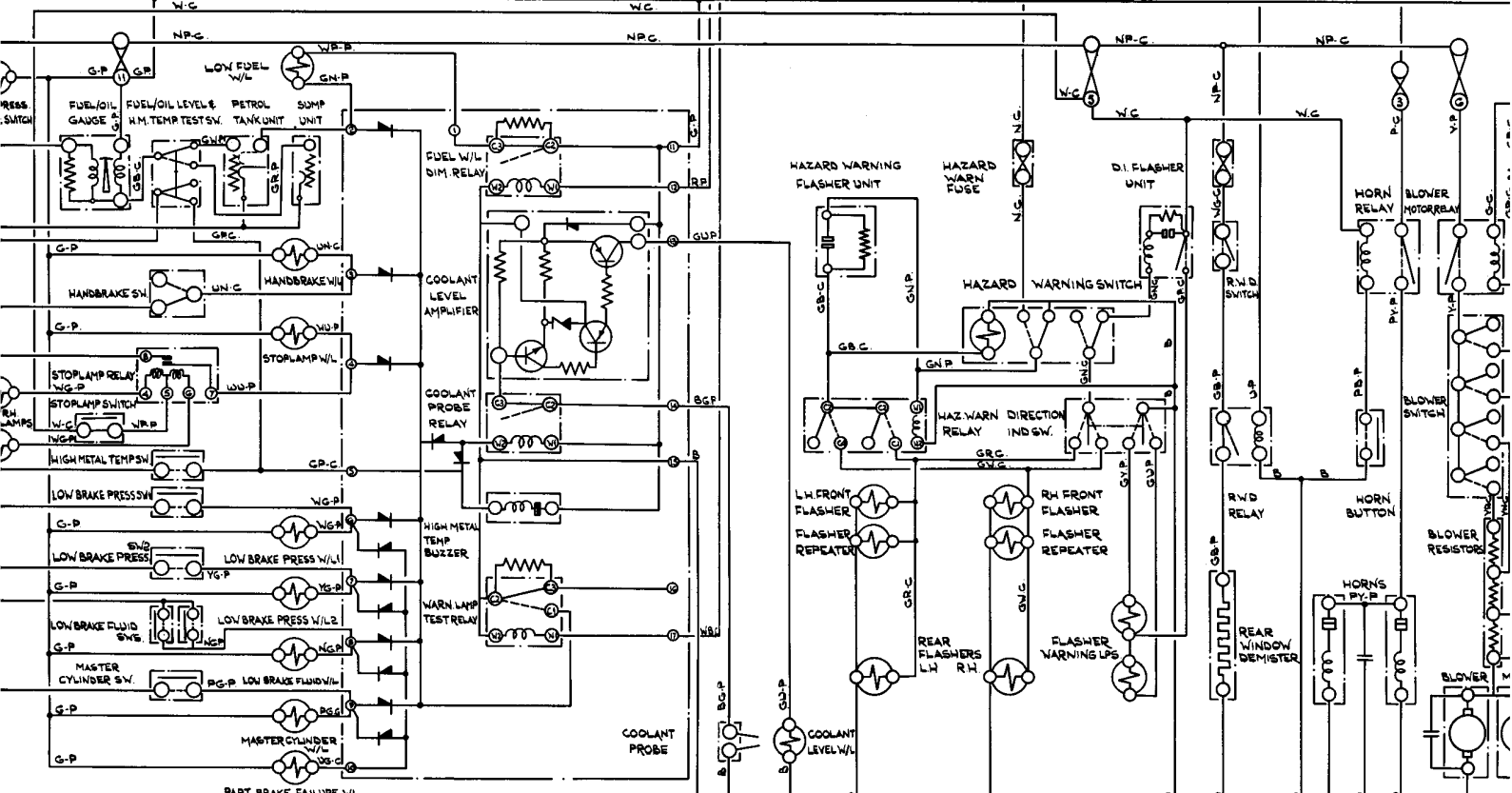
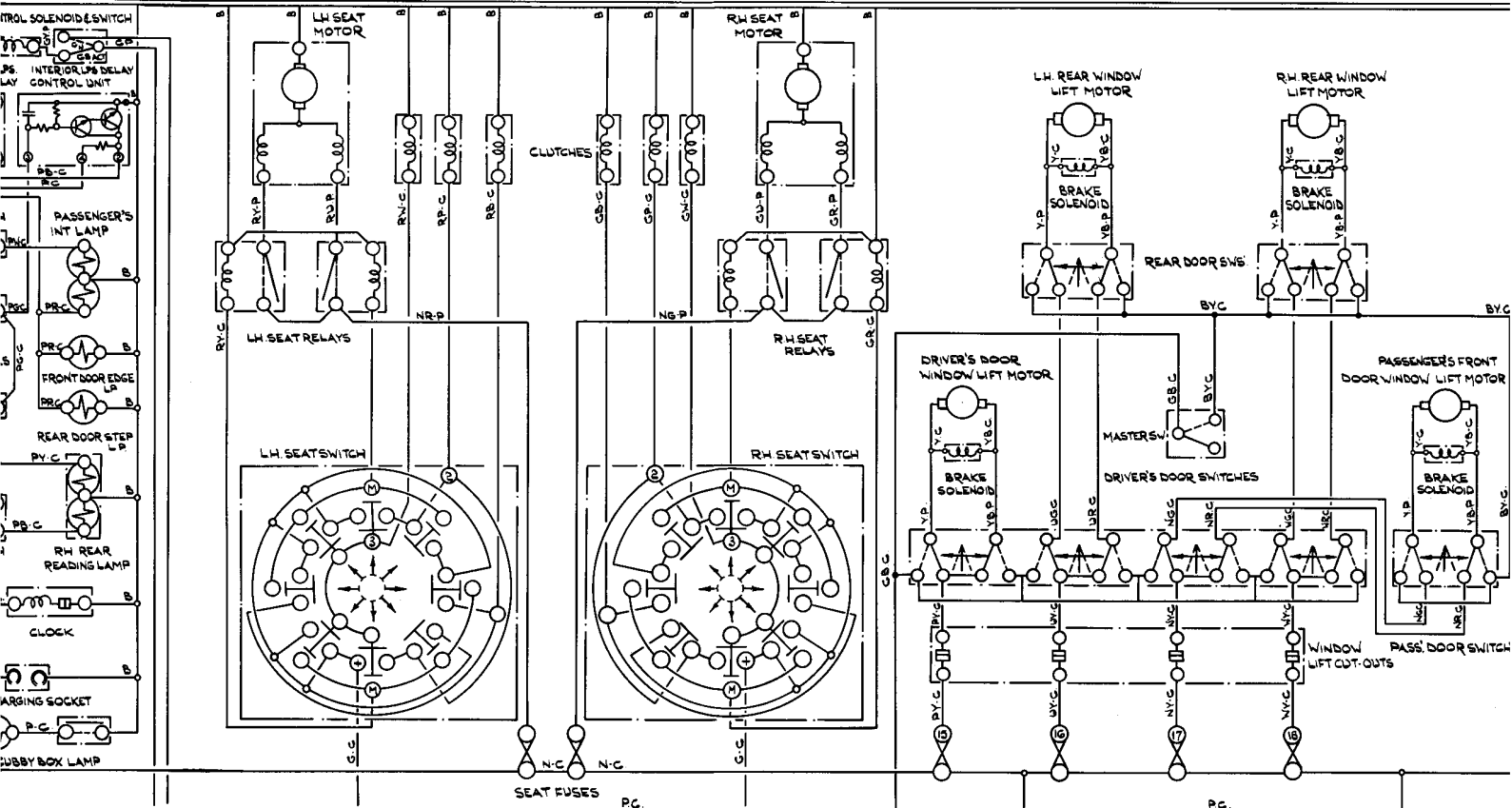

STOPLAMPS WARNING LAMPS FUEL GAUGE
HIGH METAL TEMPERATURE BUZZER COOLANT PROBE

DIRECTION INDICATORS HAZARD WARNING

REAR WINDOW
DEMISTER

HORNS

BLOWER

M. MOTORS

CENTRALISED DOOR & BOOT LID LOCKING

HEADLAMPS

SIDELAMPS

PANEL LAMPS

AIR CONDITIONING

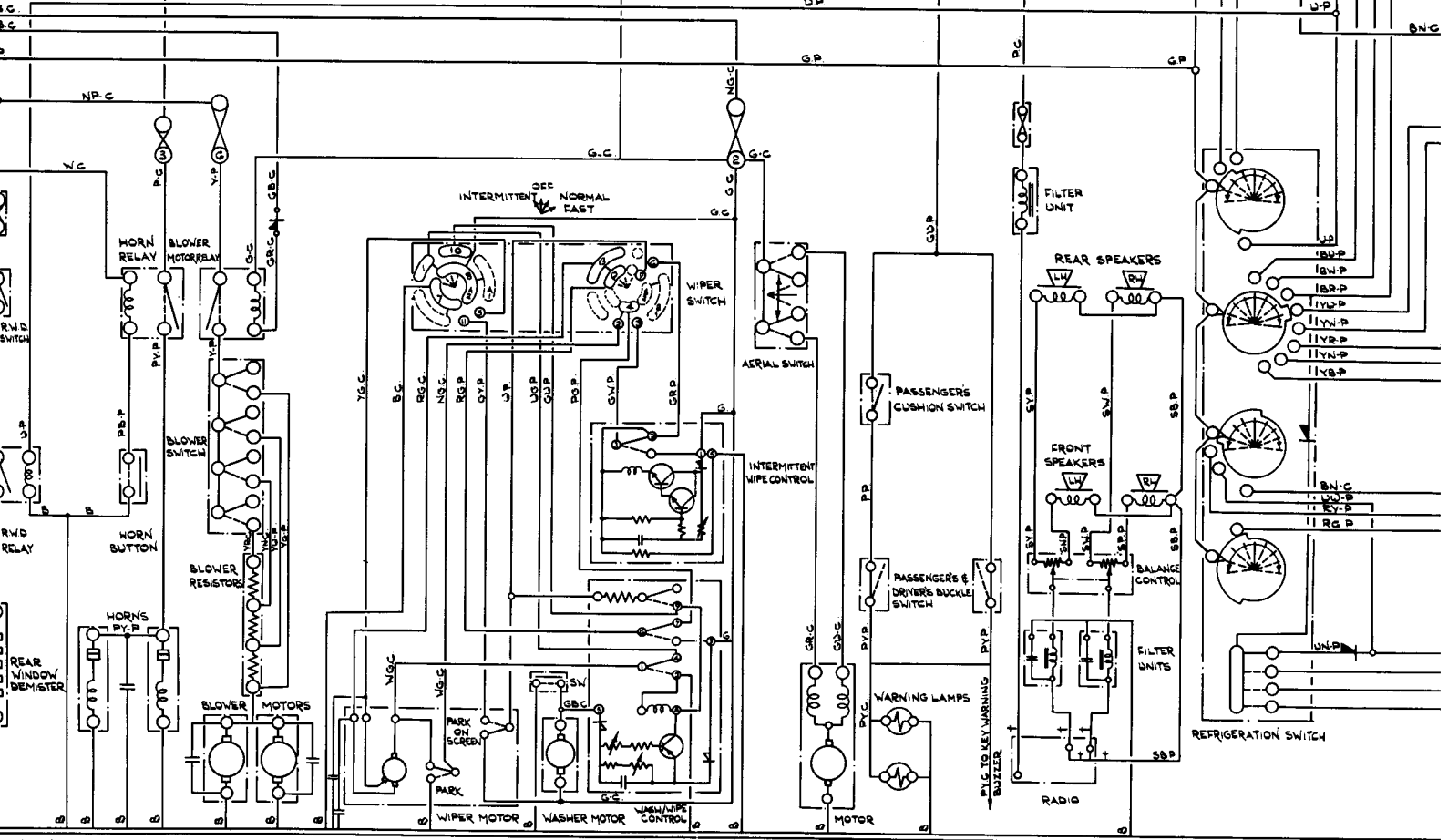
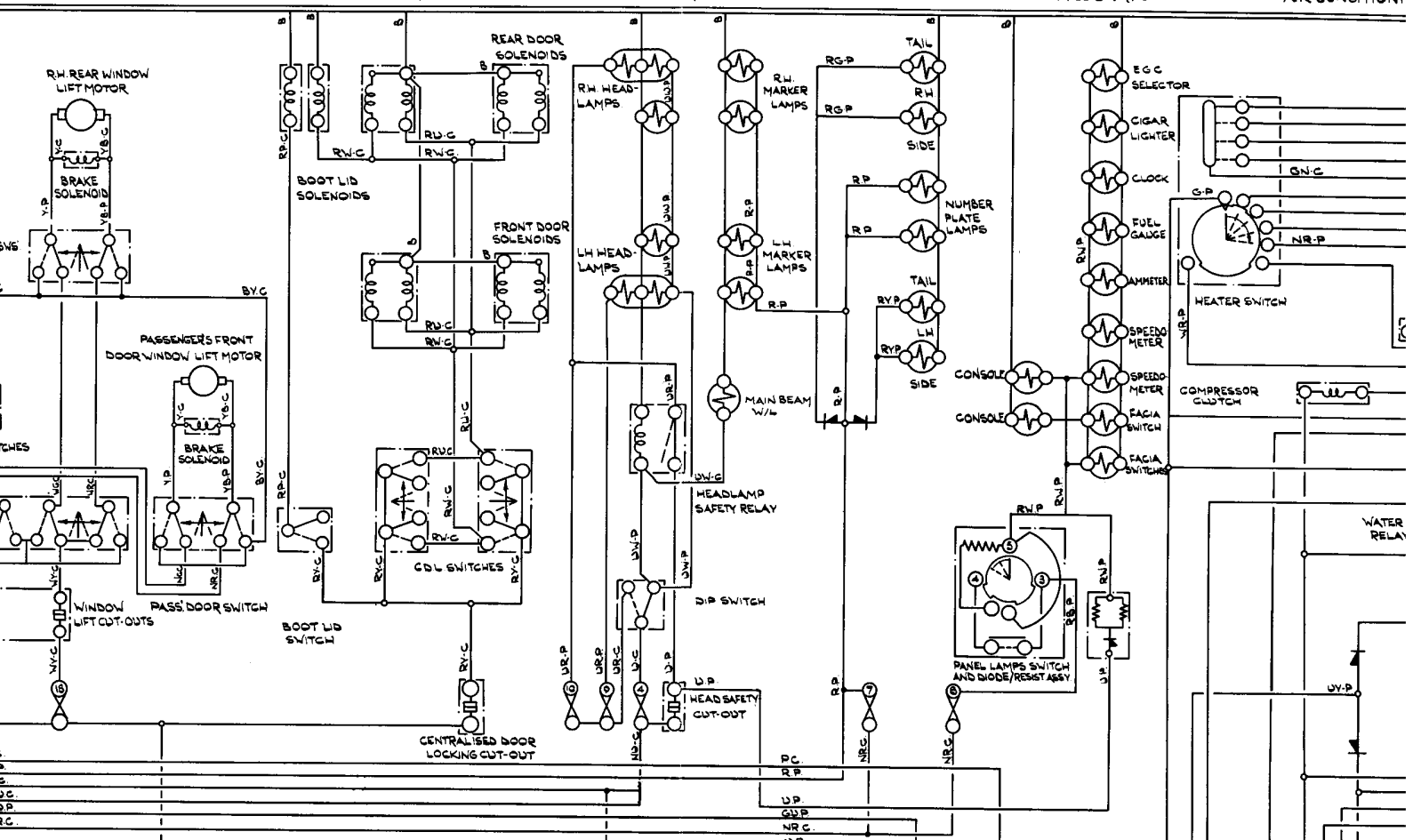

WINDOW WIPER HORNS BLOWER MOTORS WINDSCREEN WIPER (INCLUDING INTERMITTENT OPERATION) AND WASHER AERIAL SEAT BELT WARNING STEREO RADIO
 † DENOTES RADIO FLYING LEAD

ALISED DOOR & BOOT LID LOCKING

HEADLAMPS

SIDELAMPS

PANEL LAMPS

AIR CONDITIONING UNIT SYSTEM

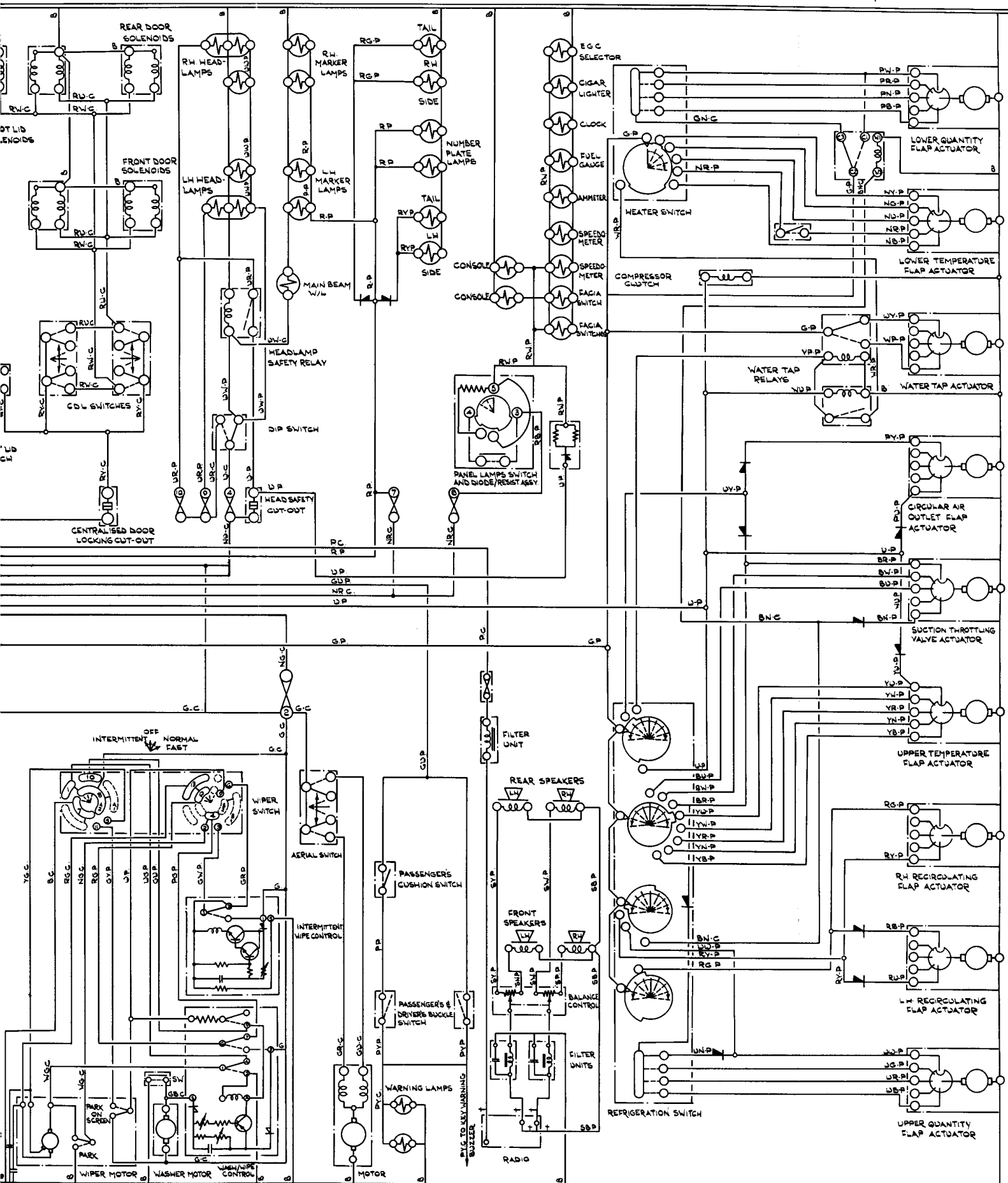

WINDSCREEN WIPER (INCLUDING INTERMITTENT OPERATION) AND WASHER

AERIAL

SEAT BELT WARNING

STEREO RADIO

+ DENOTES RADIO FLYING LEAD

THEORETICAL WIRING DIAGRAM

Sheet 12

For
Rolls-Royce Silver Shadow
and
Bentley T Series

**RIGHT-HAND DRIVE LONG WHEEL BASE
DIVISION CARS FROM CAR SERIAL
NUMBER 13754**

T.S.D. Publication 2963

“© Rolls-Royce Motors Limited 1973”

“This document is the property of Rolls-Royce Motors Limited and may not be copied or communicated to a third party or used for any purpose other than that for which it is supplied without the express written authority of Rolls-Royce Motors Limited.”

“Whilst the information in this document given in good faith based upon the latest knowledge available to Rolls-Royce Motors Limited, Rolls-Royce Motors Limited gives no warranty or representation concerning such information, and such information must not be taken as establishing any contractual or other commitment on the part of Rolls-Royce Motors Limited.”

HEIGHT CONTROL
CLOCK
CHARGING SOCKET

ELECTRICALLY OPERATED SEATS

DIVISION LIFT

ELECTRIC WINDOW LIFTS WITH PM MOTORS

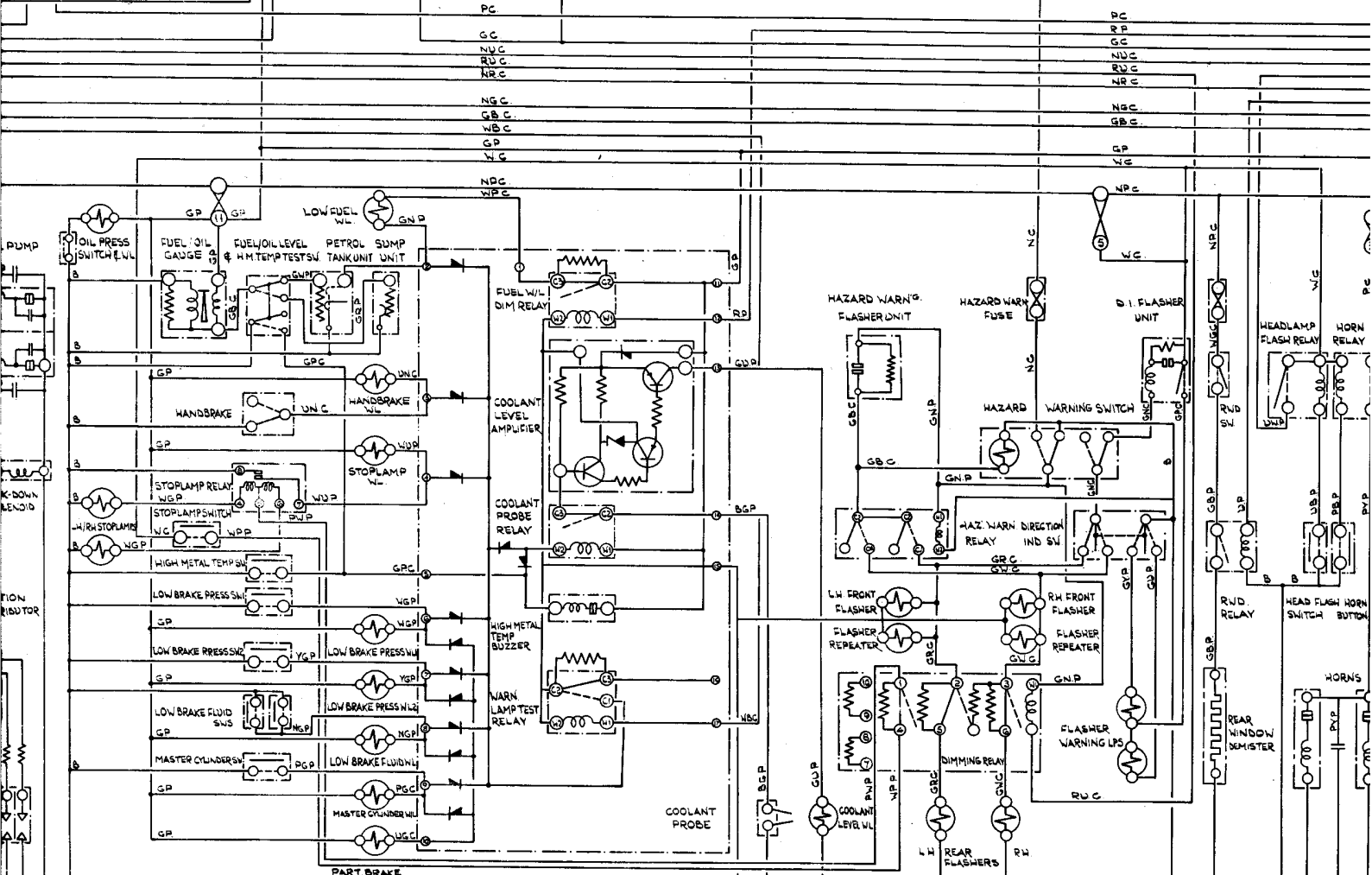
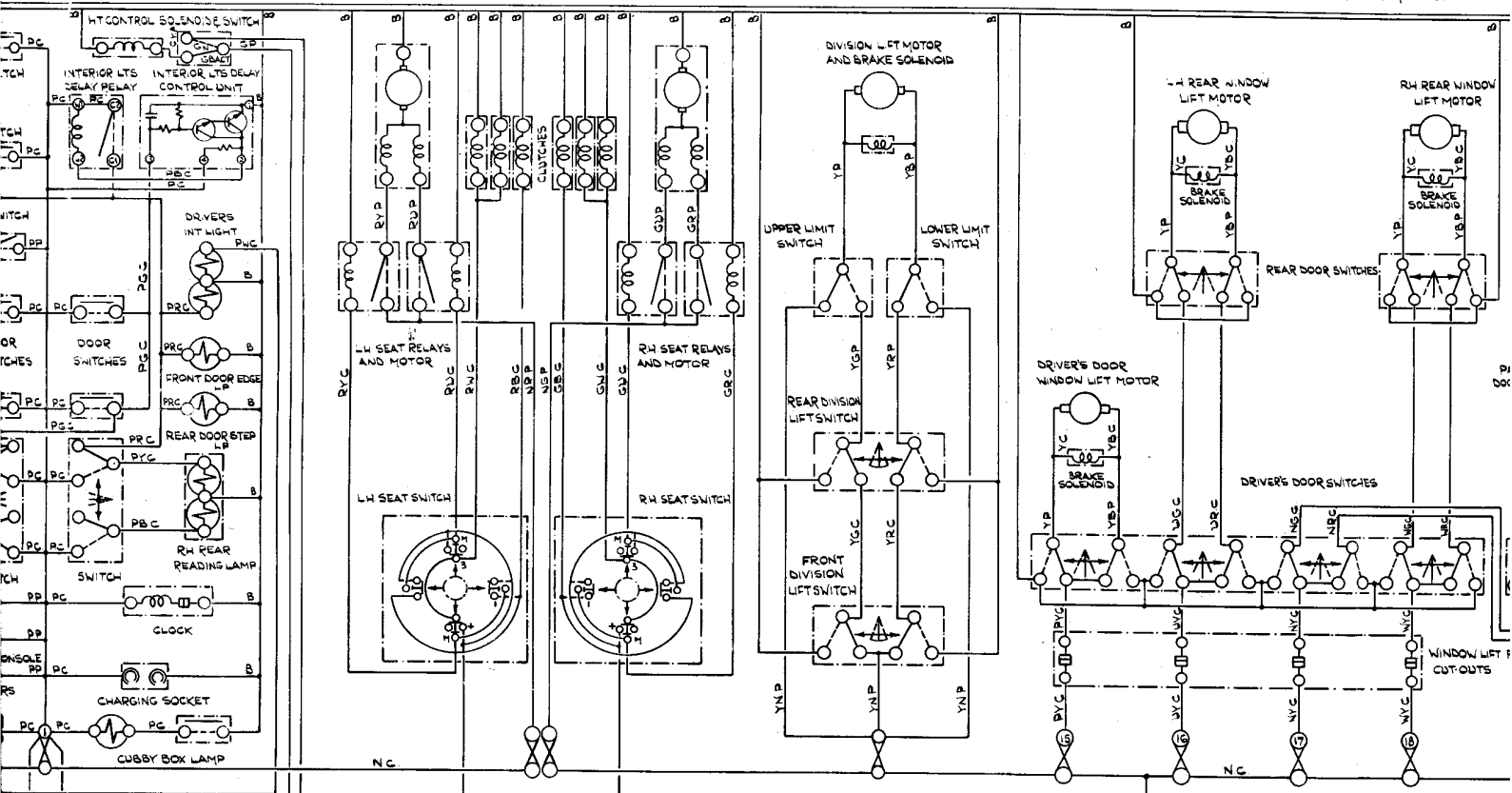

STOPLAMPS, WARNING LAMPS FUEL/OIL GAUGE, HIGH METAL TEMPERATURE BUZZER, COOLANT PROBE

DIRECTION INDICATORS HAZARD WARNING

REAR WINDOW DEMISTER
HORNS

REAR LIFTS WITH PM MOTORS

CENTRALISED DOOR AND BOOT LID LOCKING

HEADLAMPS

SIDELAMPS

PANEL LAMPS

AIR CONDITIONING UN

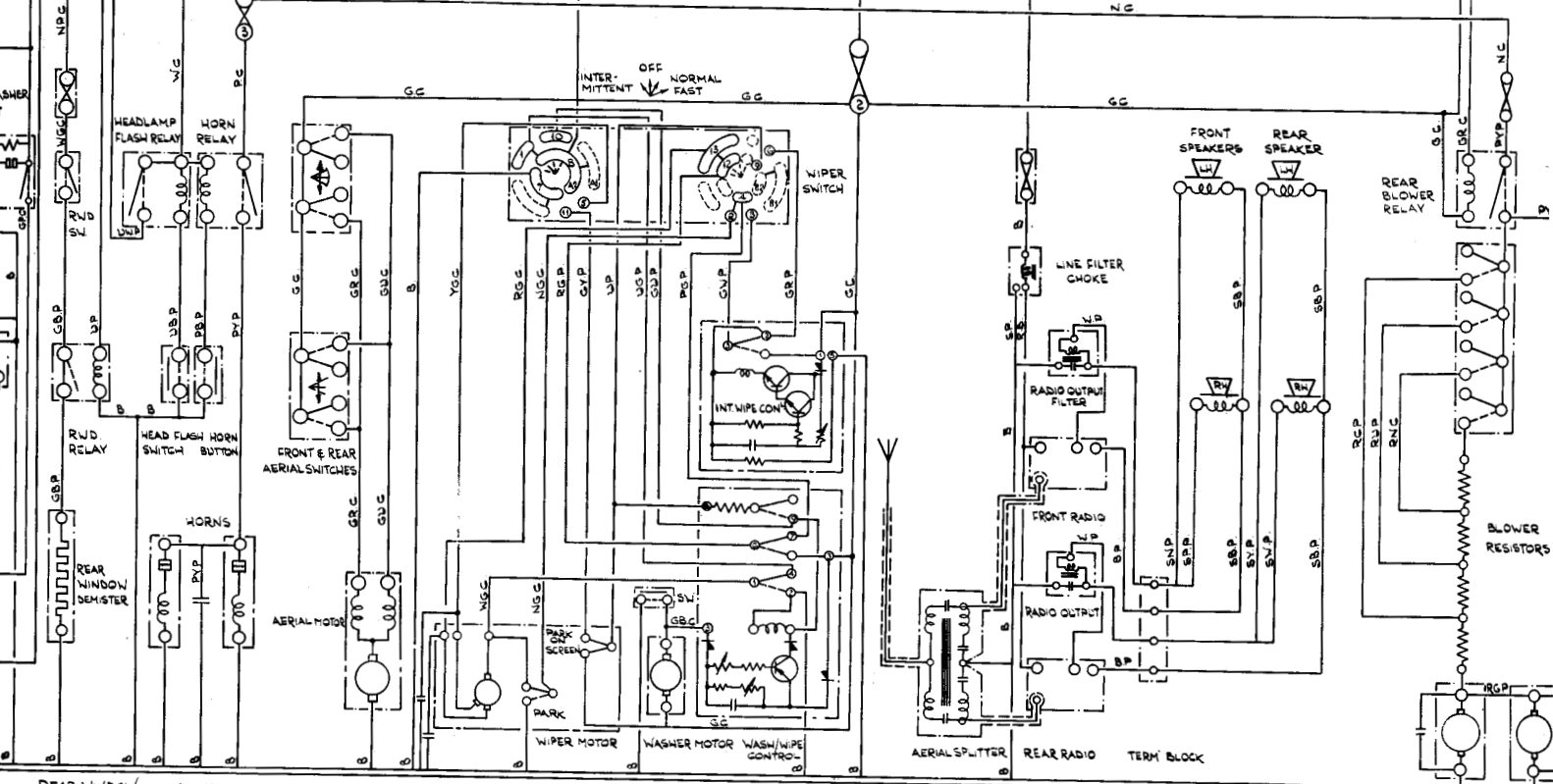
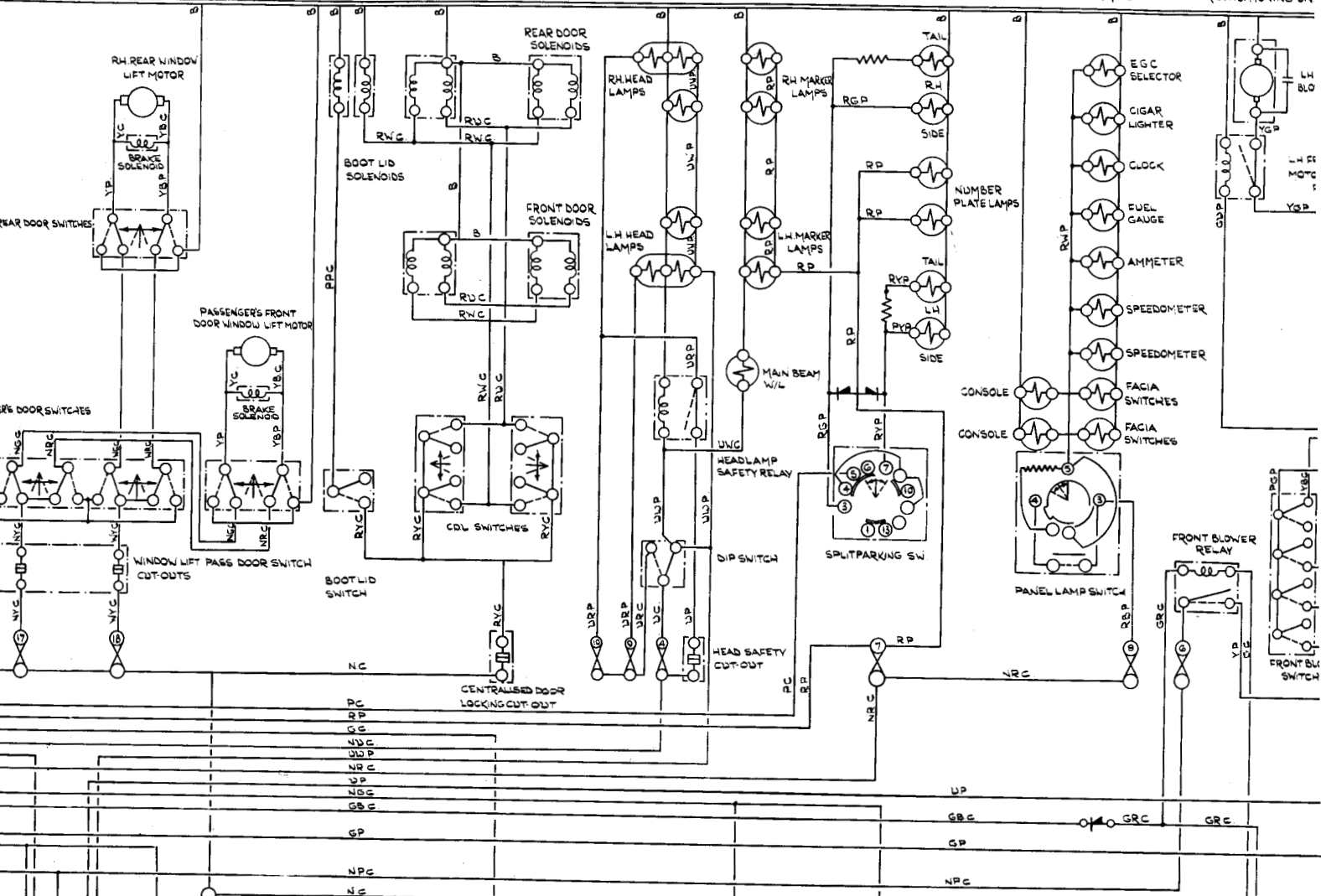

REAR WINDOW DEMISTER

HORN

AERIAL

WINDSCREEN WIPER (INCLUDING INTERMITTENT OPERATOR) AND WASHER

RADIO

LOGGAGE COMPARTMENT

PANEL LAMPS

AIR CONDITIONING UNIT FRONT BLOWER MOTORS

AIR CONDITIONING UNIT SYSTEM

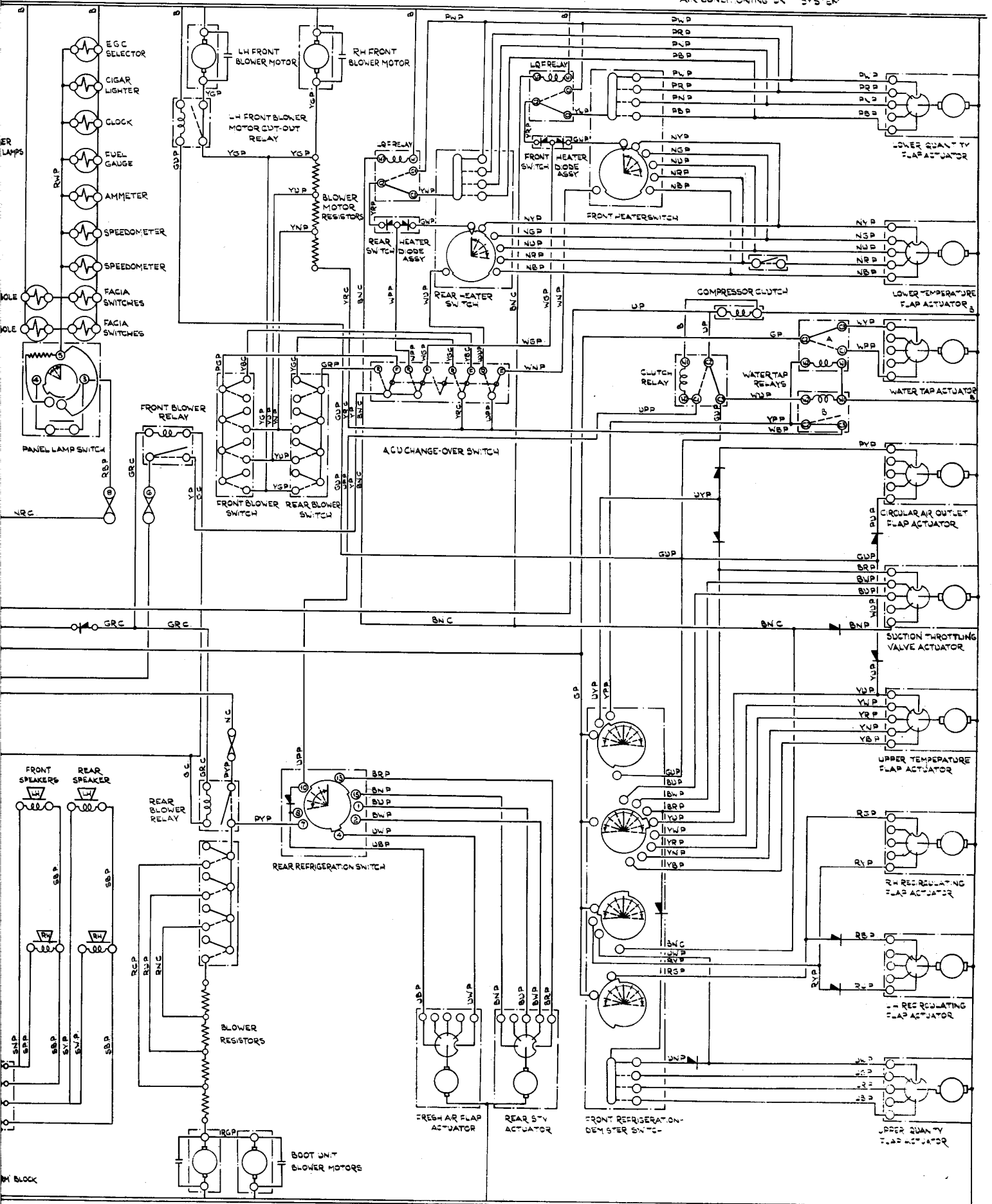

LUGGAGE COMPARTMENT (BOOT) REFRIGERATION UNIT

Section 15

All cars built to 1973
Electrical Specification
(Sheets 1-11)

Printed in England

February 1974

T.S.D. 2476

THEORETICAL WIRING DIAGRAM

Sheet 1

For
Rolls-Royce Silver Shadow
and
Bentley T Series

**RIGHT-HAND DRIVE SALOON AND LONG
WHEELBASE NON-DIVISION CARS FROM
CAR SERIAL NUMBER 16214**

T.S.D. Publication 4028

“© Rolls-Royce Motors Limited 1974”

“This document is the property of Rolls-Royce Motors Limited and may not be copied or communicated to a third party or used for any purpose other than that for which it is supplied without the express written authority of Rolls-Royce Motors Limited.”

“Whilst the information in this document given in good faith based upon the latest knowledge available to Rolls-Royce Motors Limited, Rolls-Royce Motors Limited gives no warranty or representation concerning such information, and such information must not be taken as establishing any contractual or other commitment on the part of Rolls-Royce Motors Limited.”

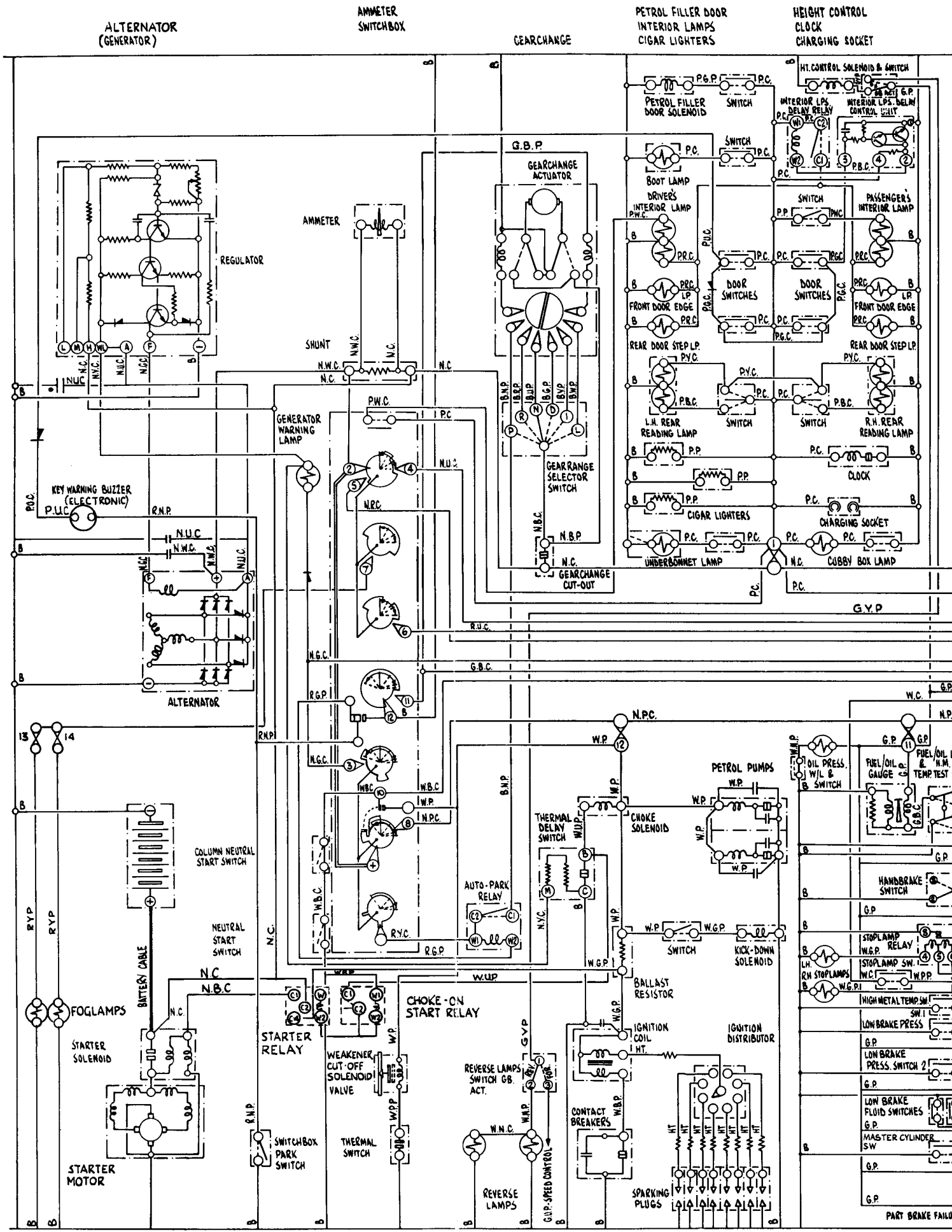

FOGLAMPS BATTERY STARTER WEAKENER CUT-OFF VALVE REVERSE LAMPS IGNITION
 KEY WARNING BUZZER CHOKE-ON START

ELECTRICALLY OPERATED SEATS

ELECTRIC WINDOW LIFTS WITH P.M. MOTORS

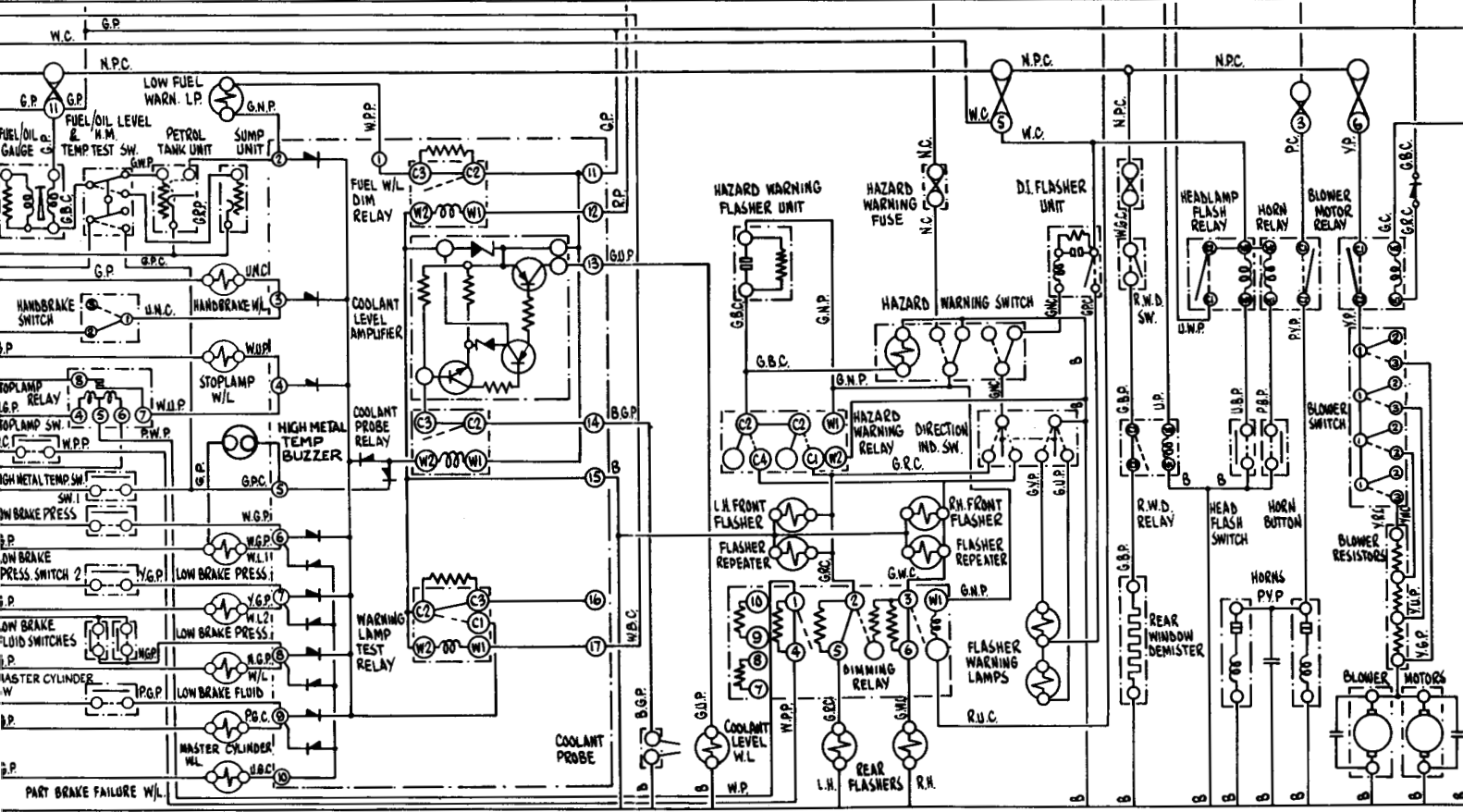
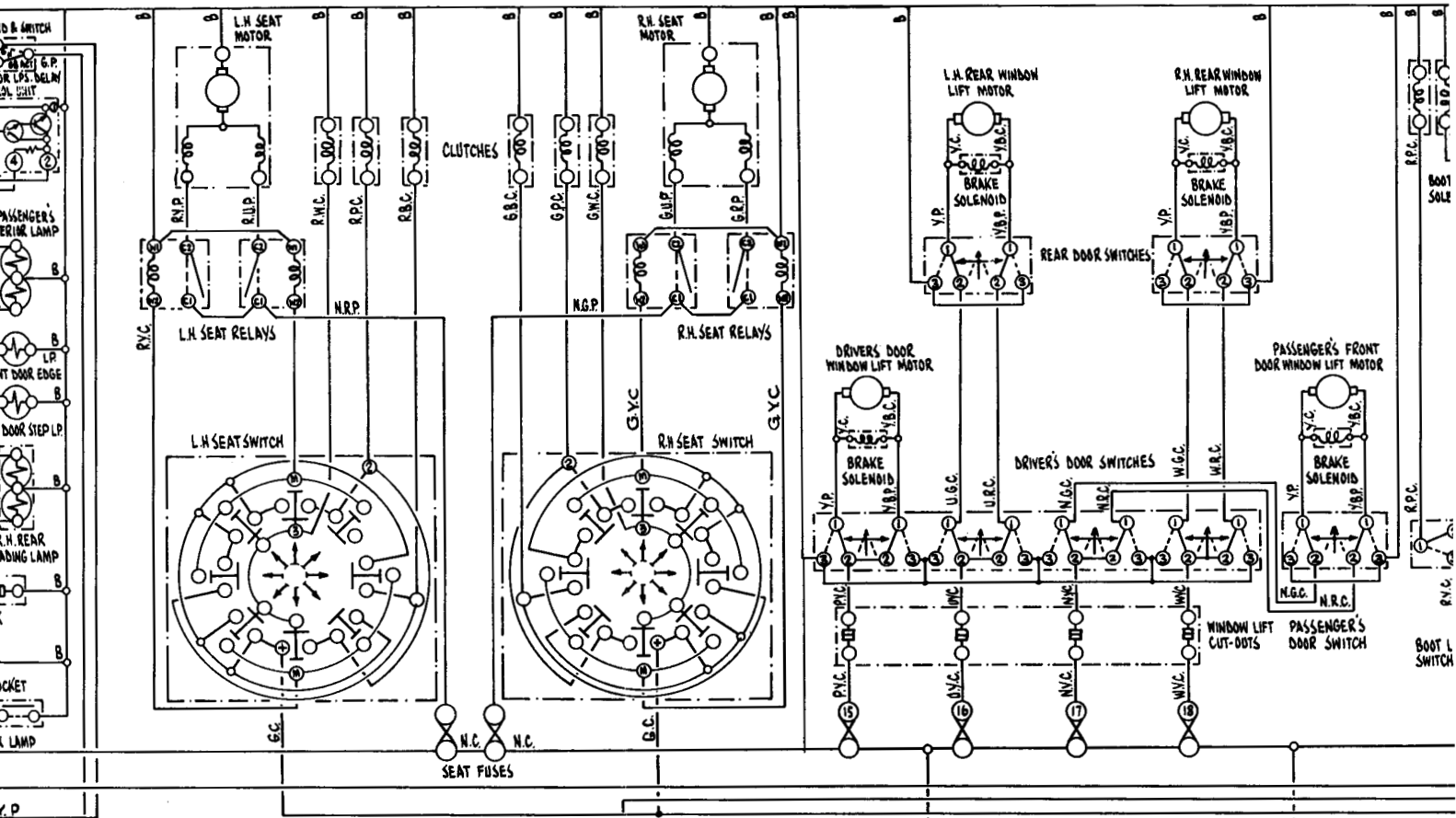

STOPLAMPS, WARNING LAMPS, FUEL GAUGE, HIGH METAL TEMPERATURE BUZZER, COOLANT PROBE.

DIRECTION INDICATORS, HAZARD WARNING

REAR WINDOW DEMISTER

HORNS

BLOWER MOTORS

CENTRALISED DOOR & BOOT LID LOCKING

HEADLAMPS

SIDELAMPS

PANEL LAMPS

AIR CONDITIONING UNIT SYSTEM

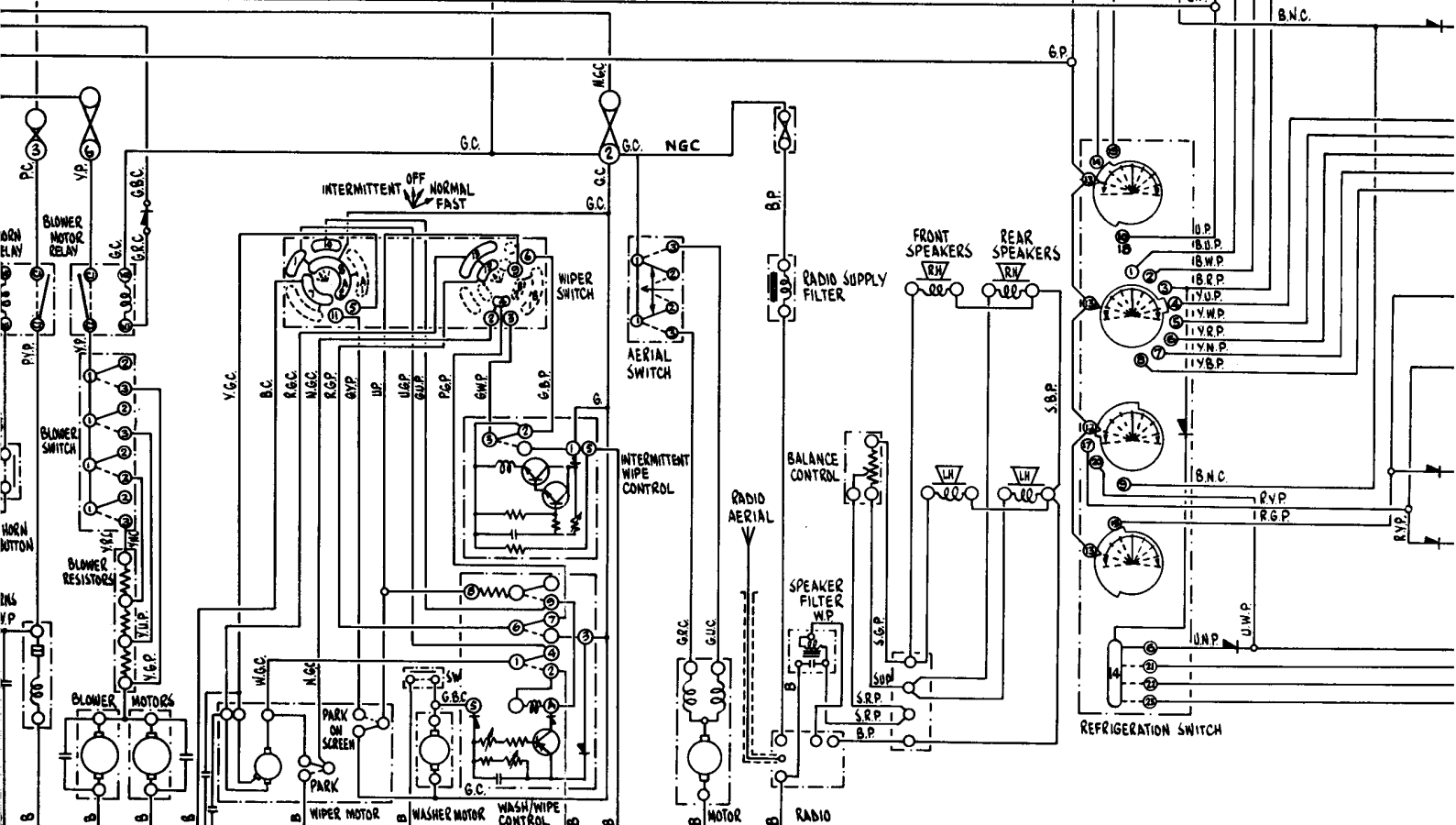
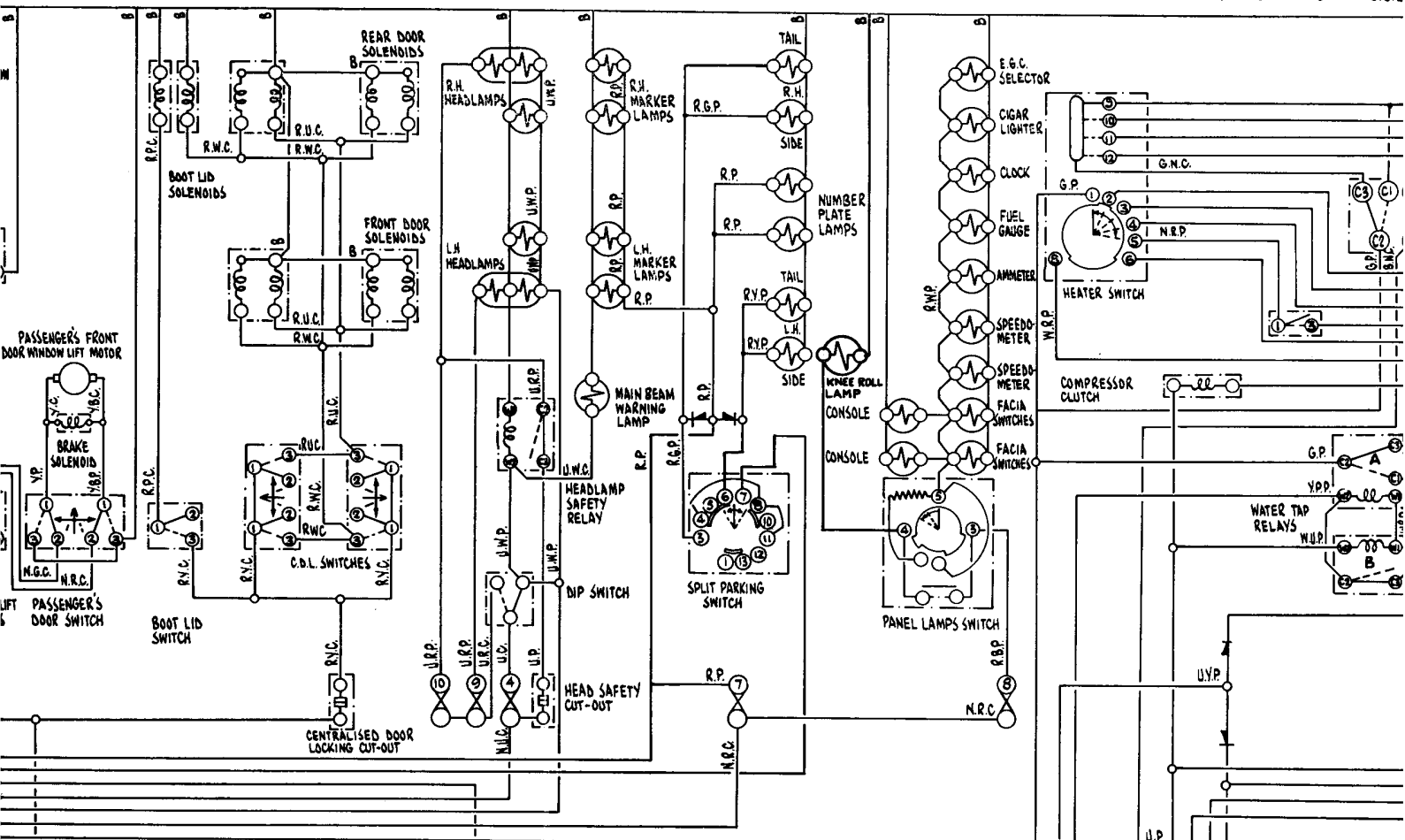

BLOWER MOTORS

WINDSCREEN WIPER (INCLUDING INTERMITTENT OPERATION) AND WASHER

AERIAL

RADIO

LOCKED DOOR & BOOT LID LOCKING

HEADLAMPS

SIDELAMPS

PANEL LAMPS

AIR CONDITIONING UNIT SYSTEM

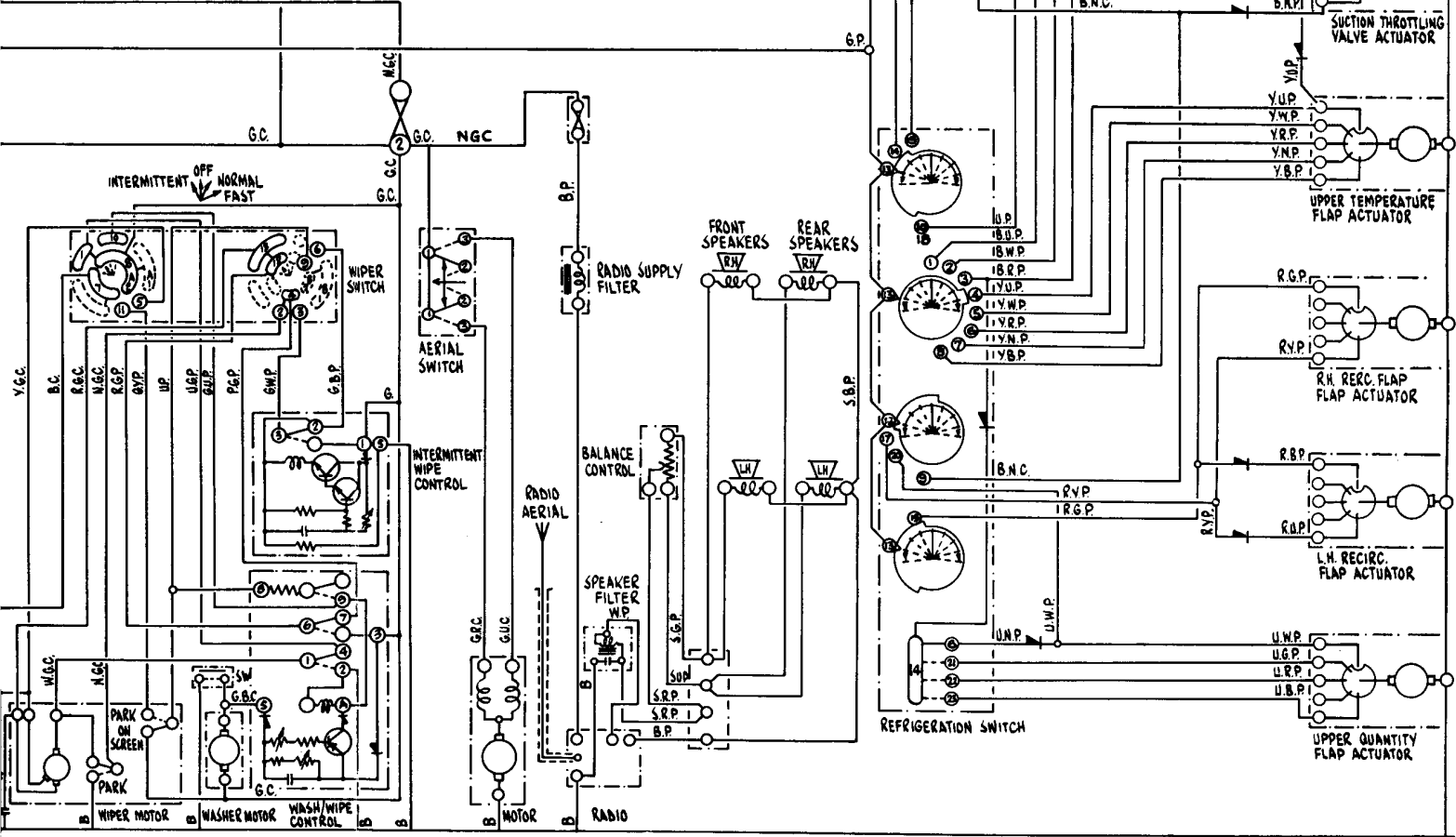
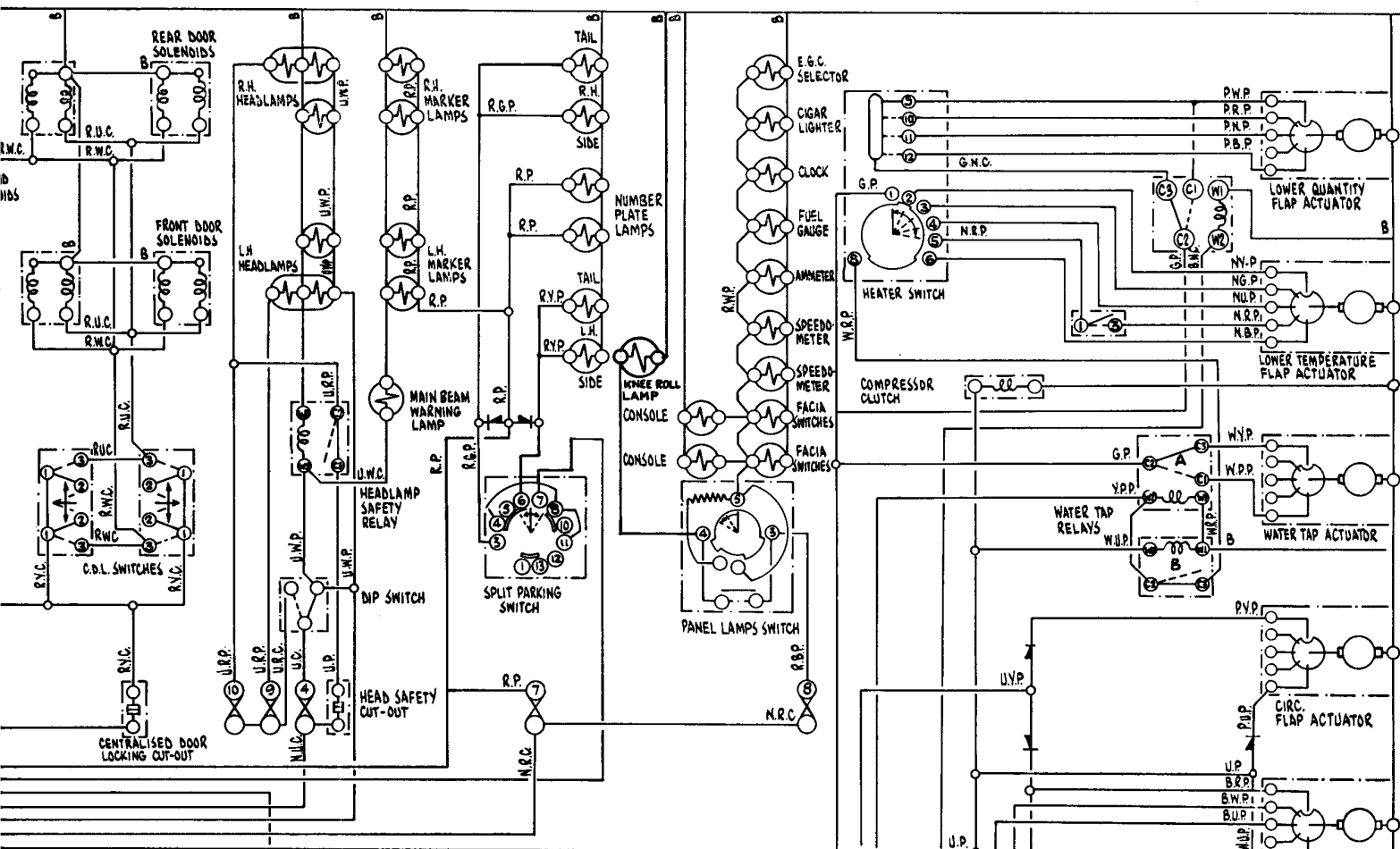

WINDSCREEN WIPER (INCLUDING INTERMITTENT OPERATION) AND WASHER

AERIAL

RADIO

THEORETICAL WIRING DIAGRAM

Sheet 2

For
Rolls-Royce Silver Shadow
and
Bentley T Series

**LONG WHEELBASE DIVISION CARS FOR
USA AND CANADA FROM CAR SERIAL
NUMBER 16214**

T.S.D. Publication 4031

"© Rolls-Royce Motors Limited 1974"

"This document is the property of Rolls-Royce Motors Limited and may not be copied or communicated to a third party or used for any purpose other than that for which it is supplied without the express written authority of Rolls-Royce Motors Limited."

"Whilst the information in this document given in good faith based upon the latest knowledge available to Rolls-Royce Motors Limited. Rolls-Royce Motors Limited gives no warranty or representation concerning such information, and such information must not be taken as establishing any contractual or other commitment on the part of Rolls-Royce Motors Limited."

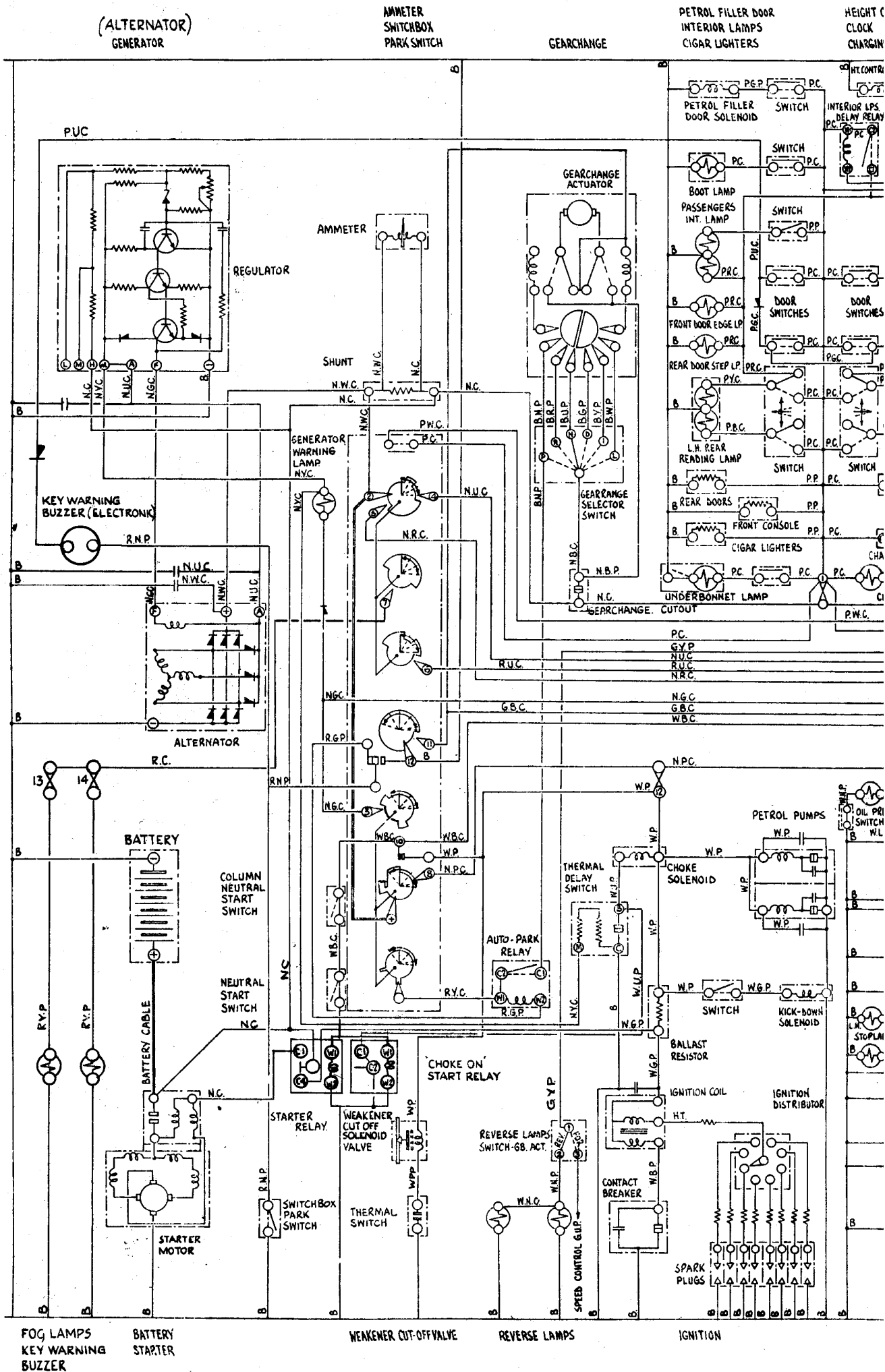

HEIGHT CONTROL
CLOCK
CHARGING SOCKET

ELECTRICALLY OPERATED SEATS

DIVISION LIFT

ELECTRIC WINDOW LIFTS WITH PM. MOTORS

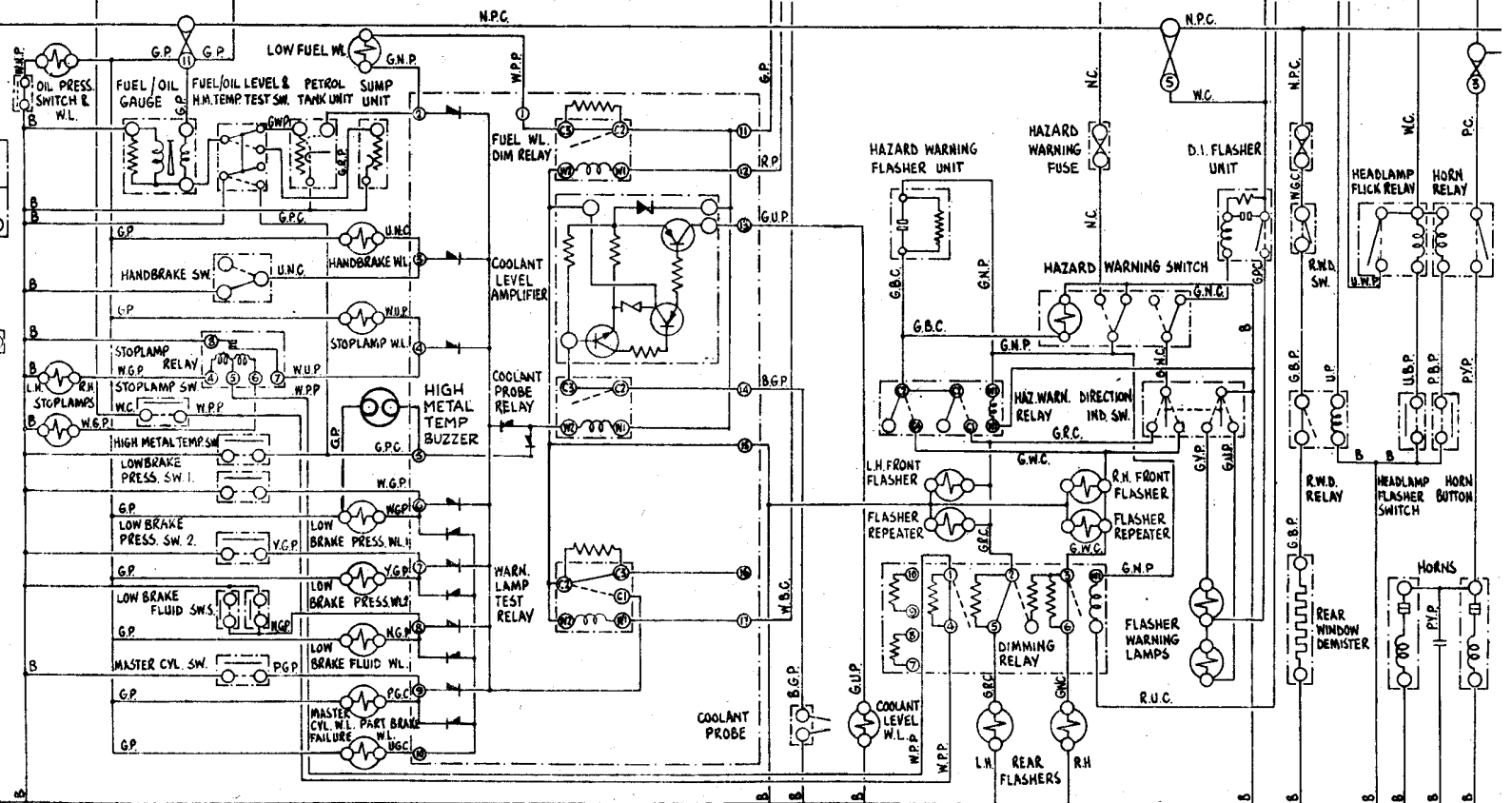
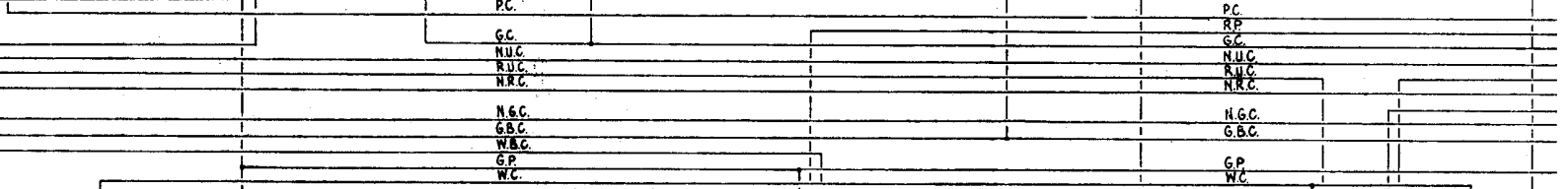
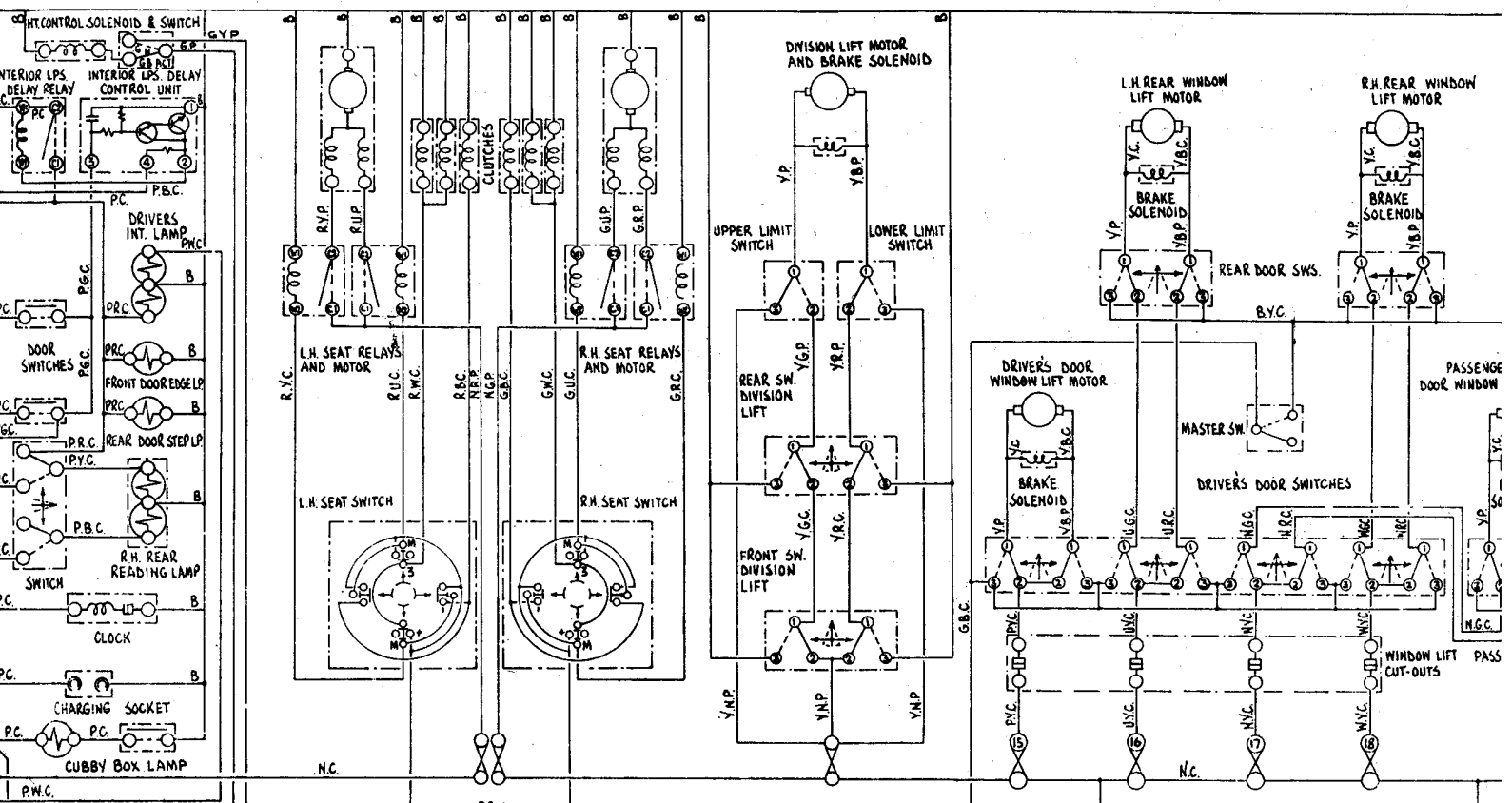

STOPLAMPS WARNING LAMPS FUEL/OIL GAUGE HIGH METAL TEMPERATURE BUZZER COOLANT PROBE

DIRECTION INDICATOR LAMPS AND HAZARD WARNING

REAR WINDOW DEMISTER

HORNS

PANEL LAMPS

AIR CONDITIONING UNIT
FRONT BLOWER MOTORS

AIR CONDITIONING UNIT SYSTEM

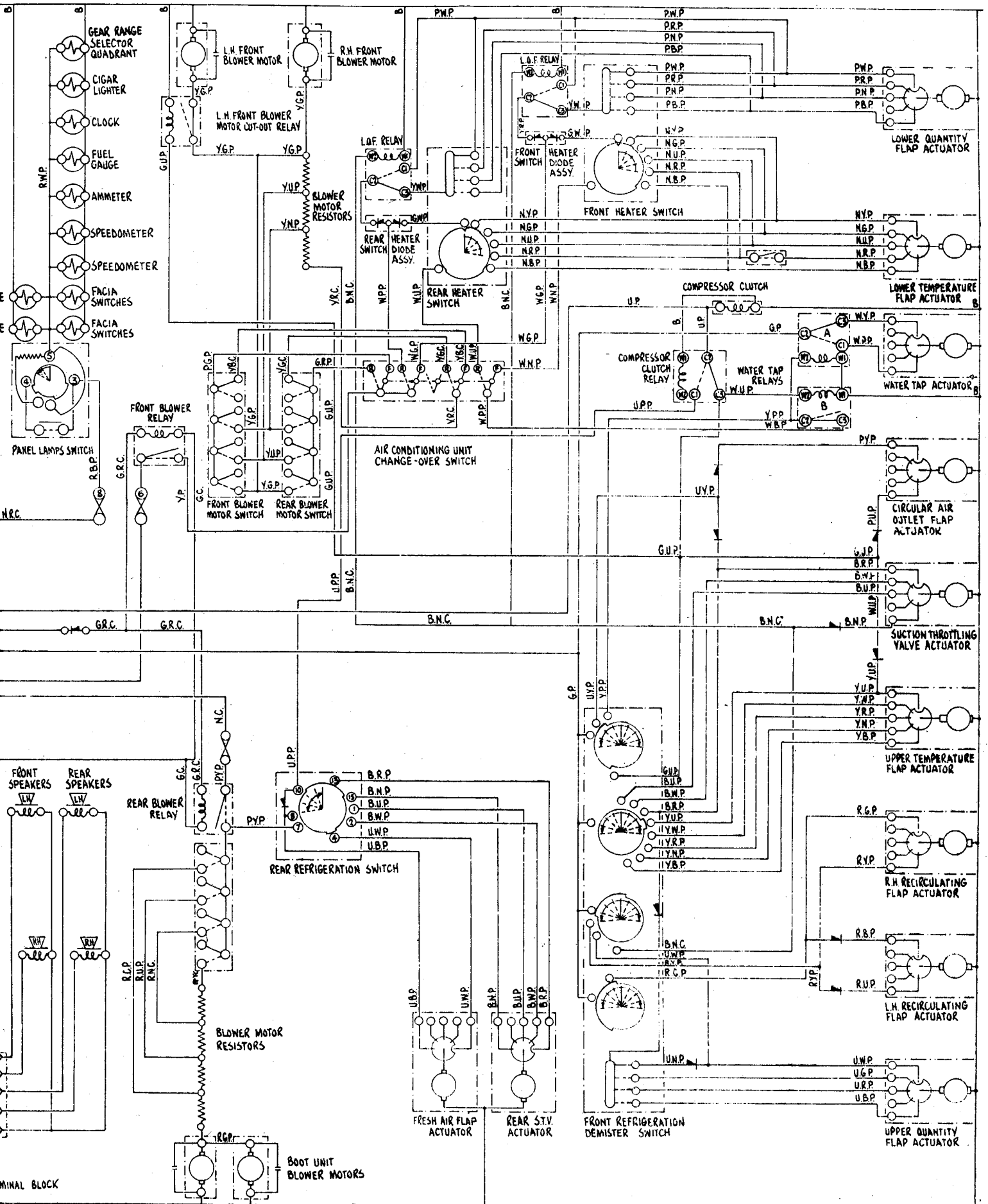

LUGGAGE COMP. REFRIGERATION UNIT

THEORETICAL WIRING DIAGRAM

Sheet 3

For
Rolls-Royce Corniche Saloon
and
Bentley Corniche Saloon

**LEFT-HAND DRIVE CARS FOR COUNTRIES
OTHER THAN USA AND CANADA FROM
CAR SERIAL NUMBER 16214**

T.S.D. Publication 4048

"© Rolls-Royce Motors Limited 1974"

"This document is the property of Rolls-Royce Motors Limited and may not be copied or communicated to a third party or used for any purpose other than that for which it is supplied without the express written authority of Rolls-Royce Motors Limited."

"Whilst the information in this document given in good faith based upon the latest knowledge available to Rolls-Royce Motors Limited, Rolls-Royce Motors Limited gives no warranty or representation concerning such information, and such information must not be taken as establishing any contractual or other commitment on the part of Rolls-Royce Motors Limited."

SIDLAMPS

PANEL LAMPS

TWO SPEED CONTROL

AIR CONDITIONING UNIT SYSTEM

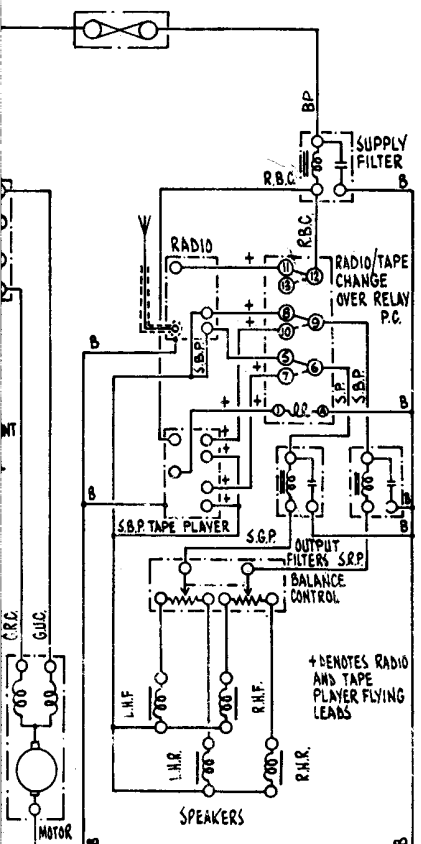
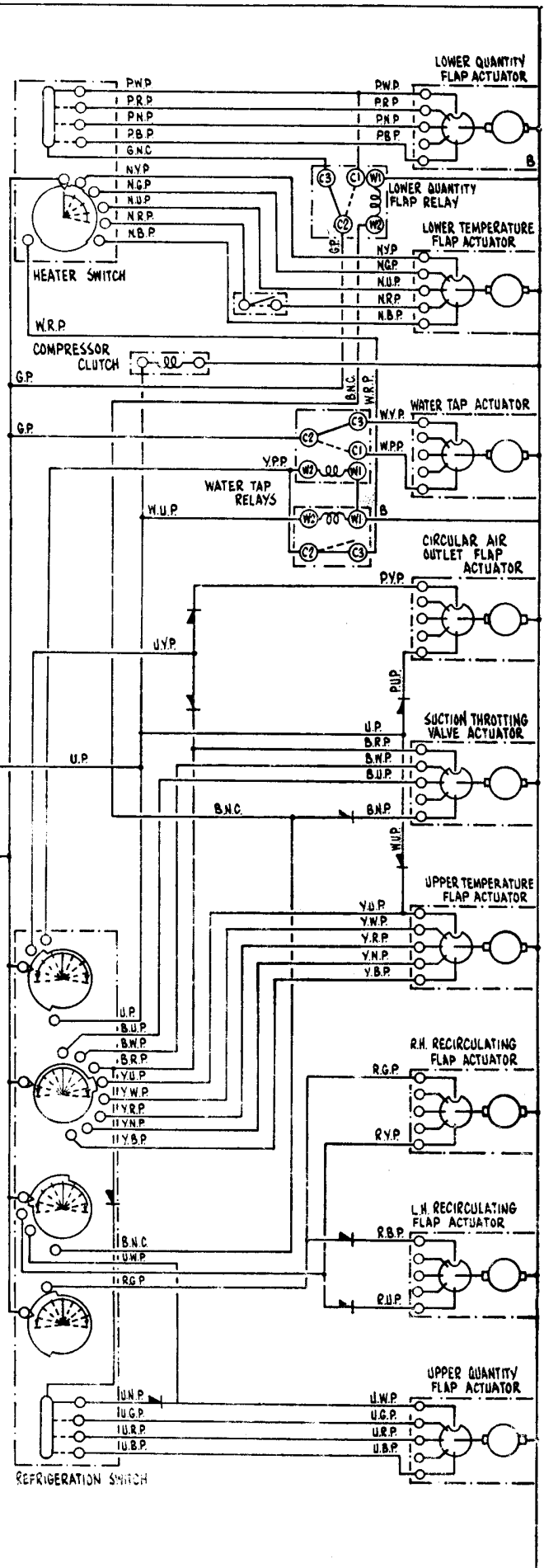
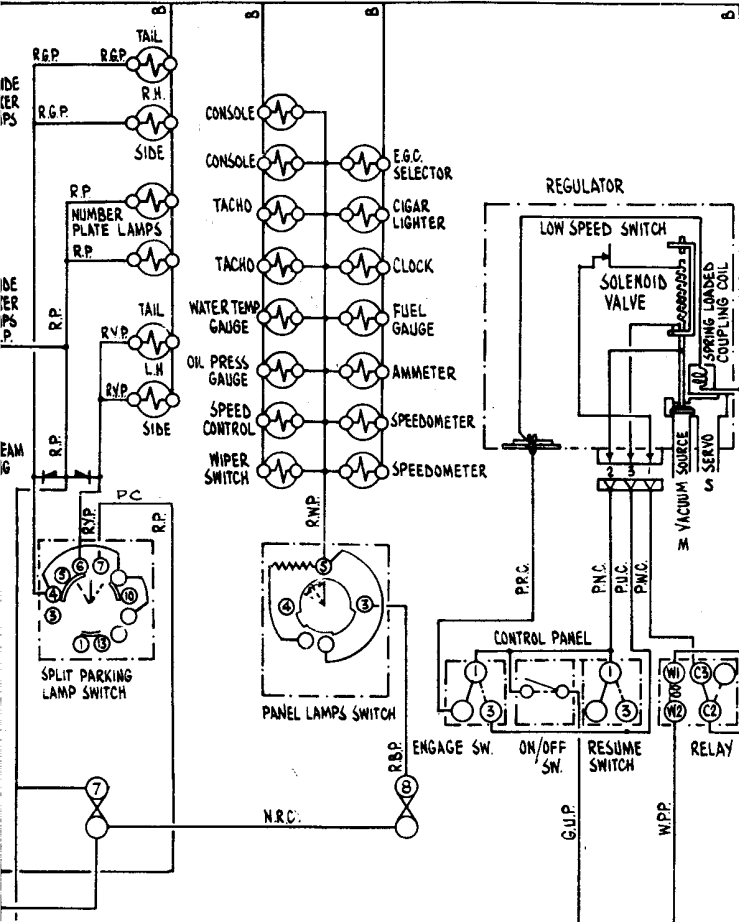

RADIO AND TAPE PLAYER
STEREO RADIO/STEREO TAPE

THEORETICAL WIRING DIAGRAM

Sheet 4

For
Rolls-Royce Corniche Saloon
and
Bentley Corniche Saloon

**LEFT-HAND DRIVE CARS FOR USA AND
CANADA FROM CAR SERIAL NUMBER
16214**

T.S.D. Publication 4054

“© Rolls-Royce Motors Limited 1974”

“This document is the property of Rolls-Royce Motors Limited and may not be copied or communicated to a third party or used for any purpose other than that for which it is supplied without the express written authority of Rolls-Royce Motors Limited.”

“Whilst the information in this document given in good faith based upon the latest knowledge available to Rolls-Royce Motors Limited. Rolls-Royce Motors Limited gives no warranty or representation concerning such information, and such information must not be taken as establishing any contractual or other commitment on the part of Rolls-Royce Motors Limited.”

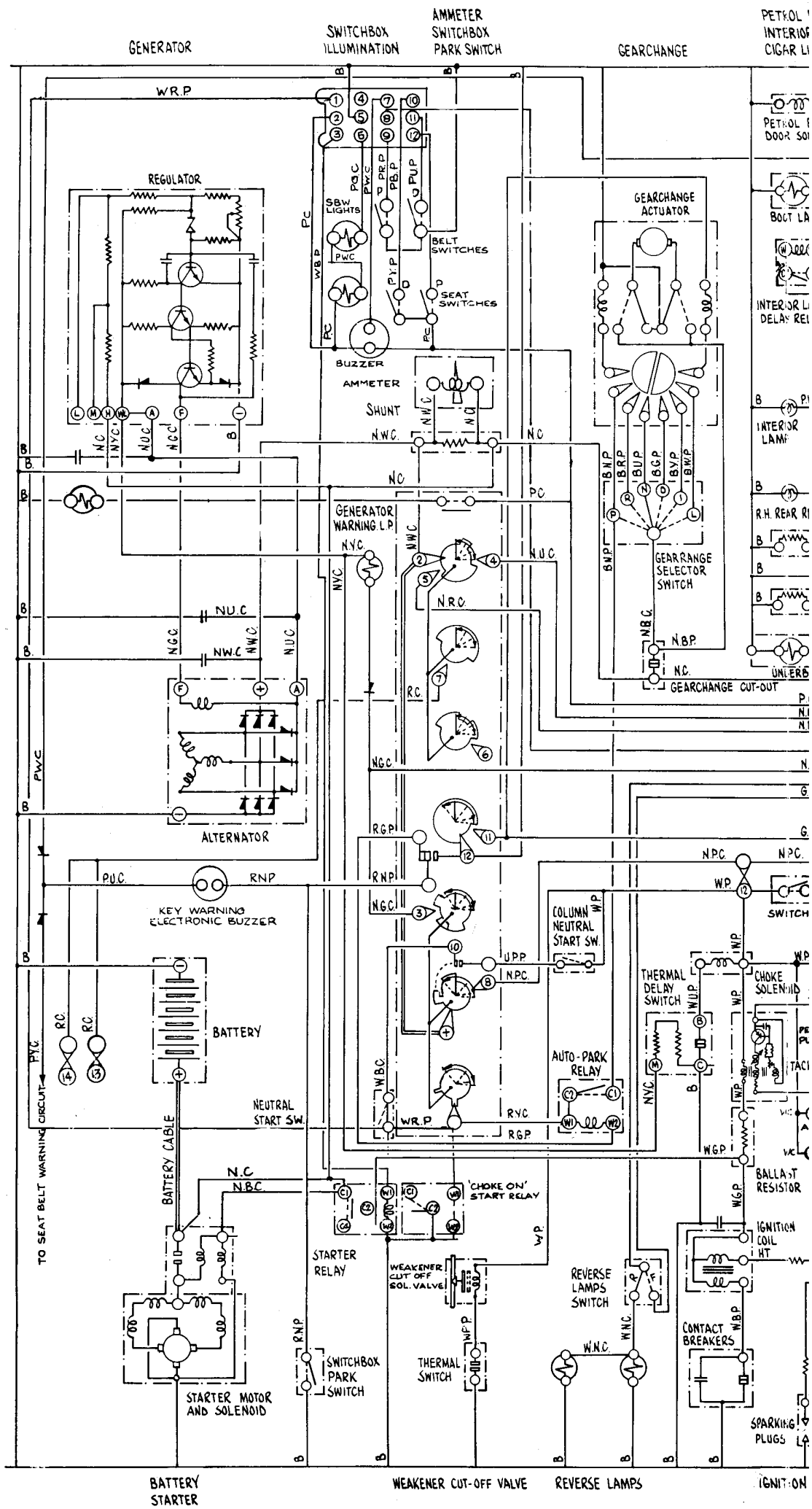

PETROL FILLER DOOR
INTERIOR LAMPS
CIGAR LIGHTERS

HEIGHT CONTROL
CLOCK
CHARGING SOCKET

ELECTRICALLY OPERATED SEATS

ELECTR

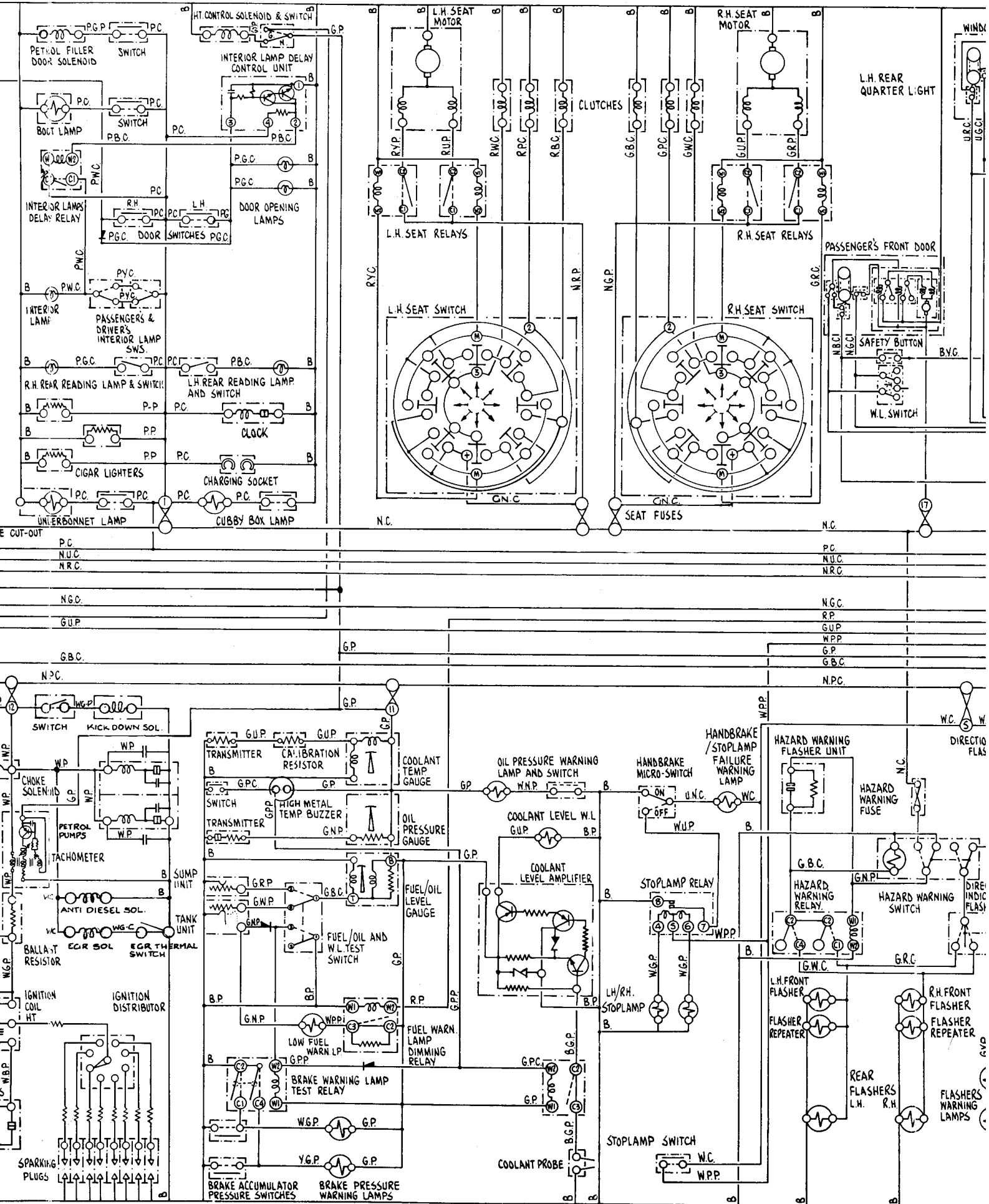

IGNITION

STOPLAMPS, WARNING LAMPS FUEL - OIL PRESSURE - WATER TEMP
GAUGES. HIGH METAL TEMPERATURE BUZZER. COOLANT PROBE.

DIRECTION INDICATORS HAZARD WARNING

ELECTRIC WINDOW LIFTS

CENTRALISED DOOR BOOT LID LOCKING

HEADLAMPS

SIDELAMPS

PANEL LAMPS

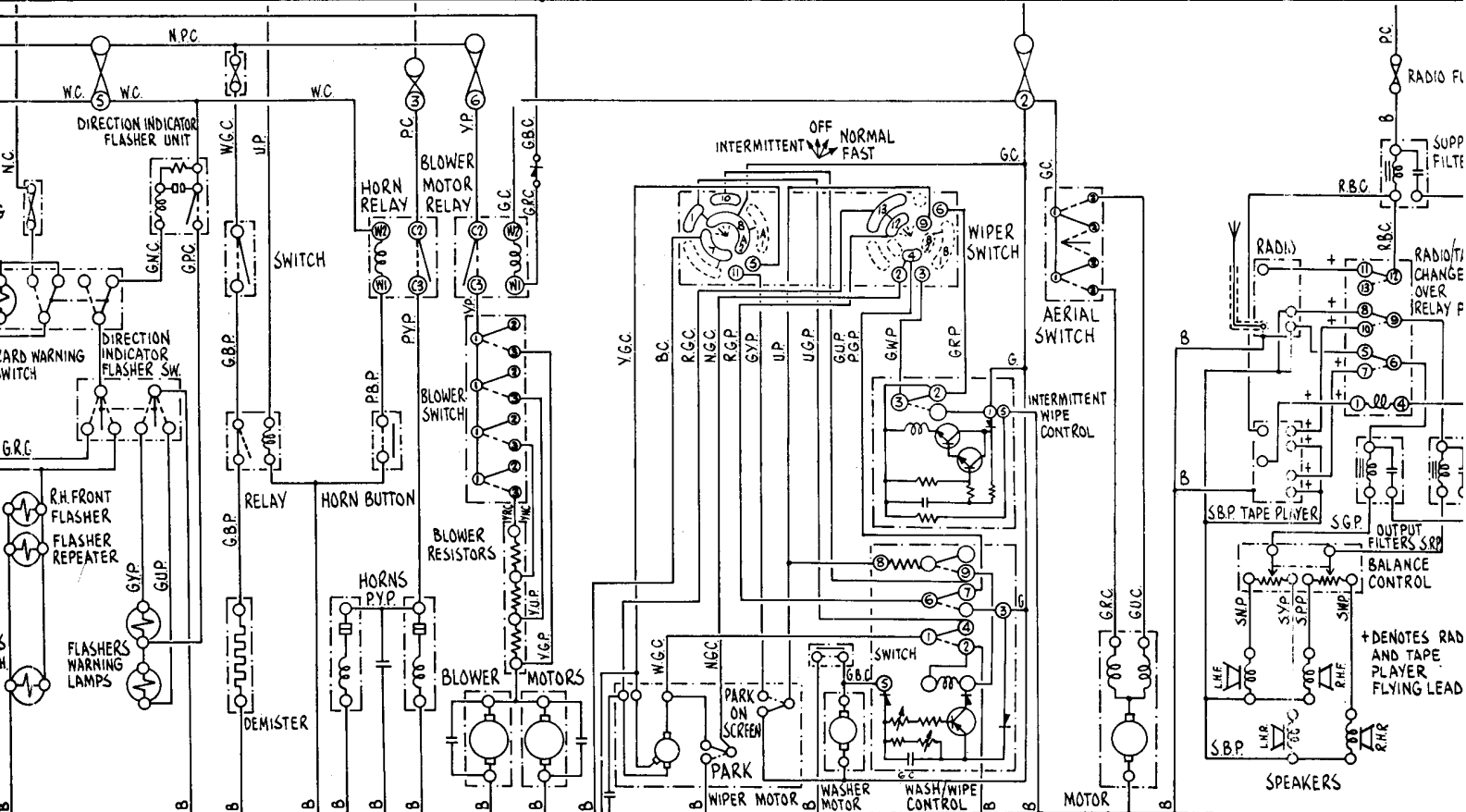
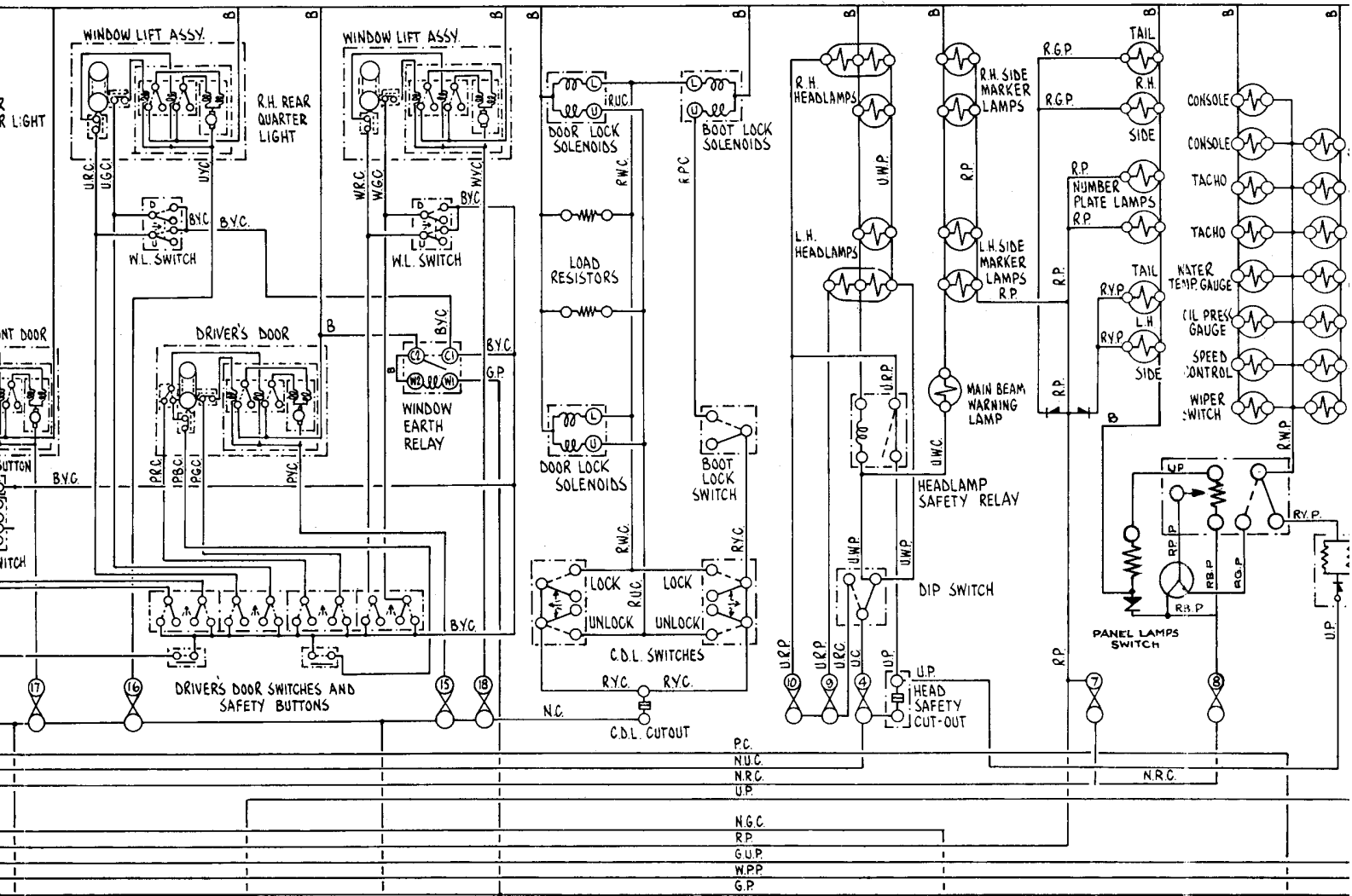

HAZARD WARNING REAR WINDOW DEMISTER HORNS BLOWER MOTORS WINDSCREEN WIPER (INCLUDING INTERMITTENT OPERATION) AND WASHER AERIAL RADIO AND TAPE PLAYER STEREO RADIO STEREO TAPE

SIDELAMPS

PANEL LAMPS

INDICATORS SPEED CONTROL

AIR CONDITIONING UNIT SYSTEM

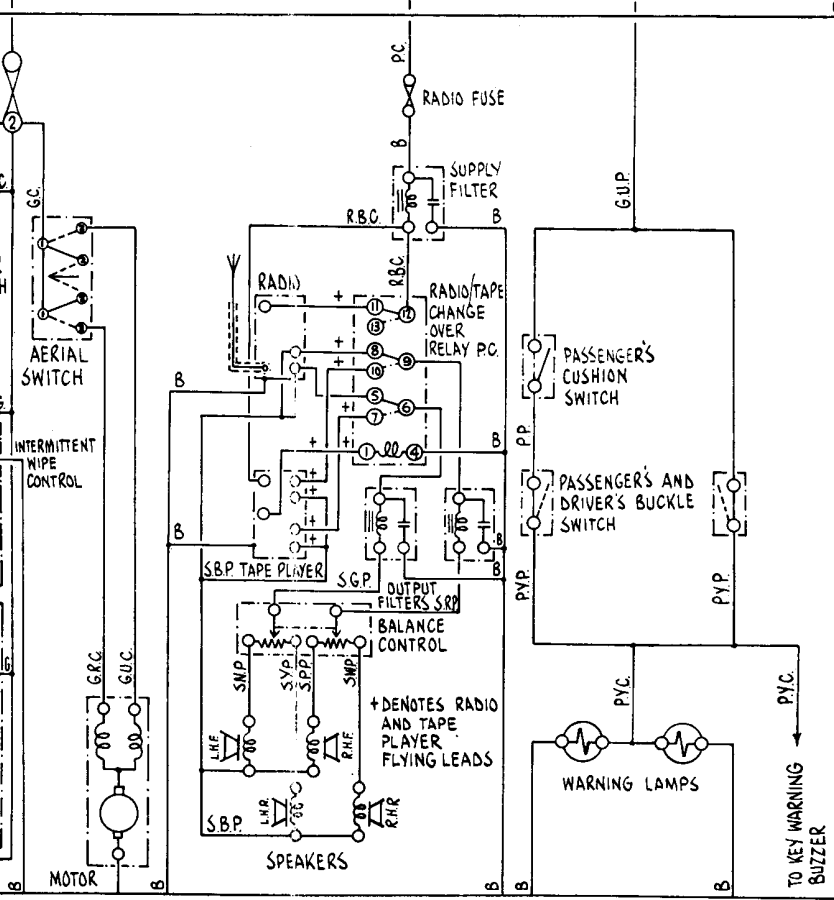
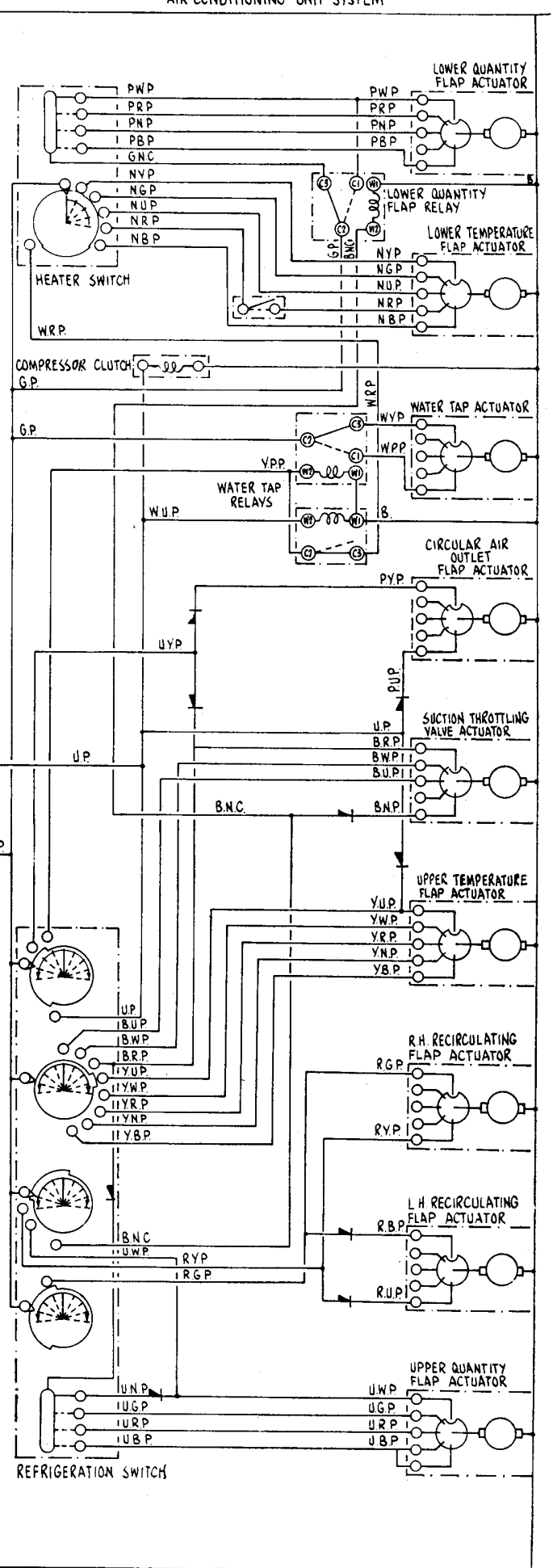
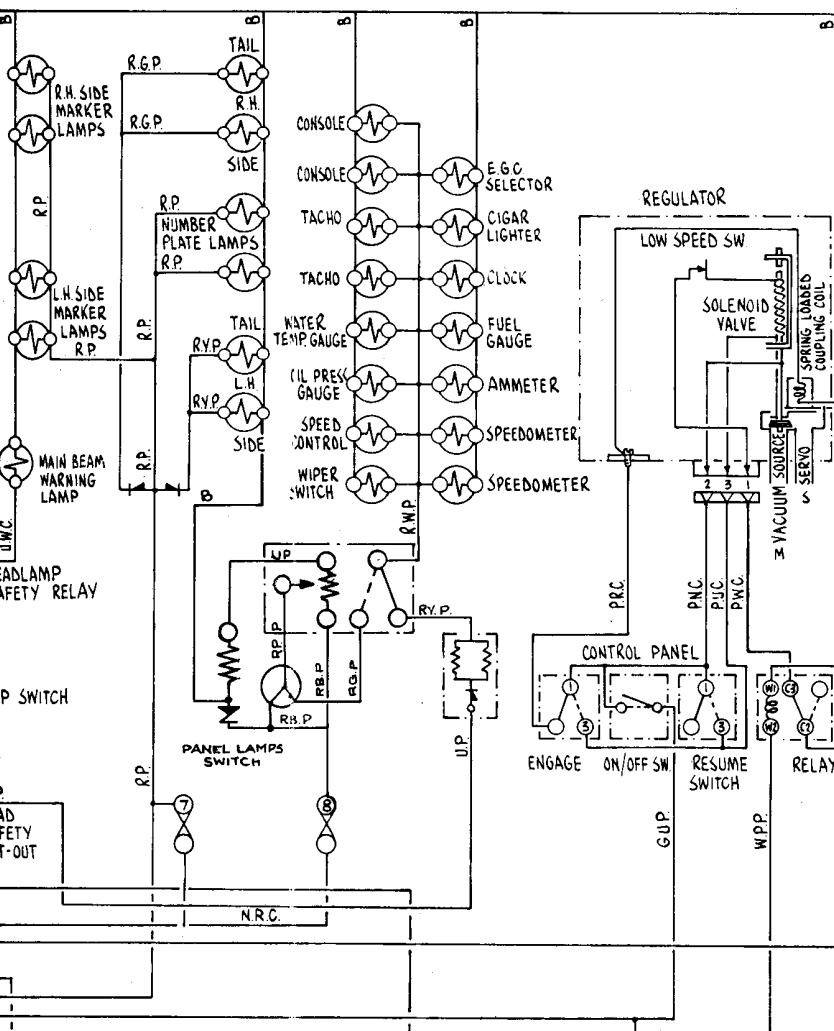

AERIAL RADIO AND TAPE PLAYER STEREO RADIO STEREO TAPE

SEAT BELT WARNING

THEORETICAL WIRING DIAGRAM

Sheet 5

For
Rolls-Royce Corniche Saloon
and
Bentley Corniche Saloon

RIGHT-HAND DRIVE CARS FROM CAR SERIAL NUMBER 16214

T.S.D. Publication 4050

“© Rolls-Royce Motors Limited 1974”

“This document is the property of Rolls-Royce Motors Limited and may not be copied or communicated to a third party or used for any purpose other than that for which it is supplied without the express written authority of Rolls-Royce Motors Limited.”

“Whilst the information in this document given in good faith based upon the latest knowledge available to Rolls-Royce Motors Limited, Rolls-Royce Motors Limited gives no warranty or representation concerning such information, and such information must not be taken as establishing any contractual or other commitment on the part of Rolls-Royce Motors Limited.”

GENERATOR SWITCHBOX ILLUMINATION AMMETER SWITCHBOX PARK SWITCH GEARCHANGE PETROL FILLER DOOR INT. LAMPS CIGAR LIGHTER HEIGHT CONTROL CLOCK CHARGING SOCKET

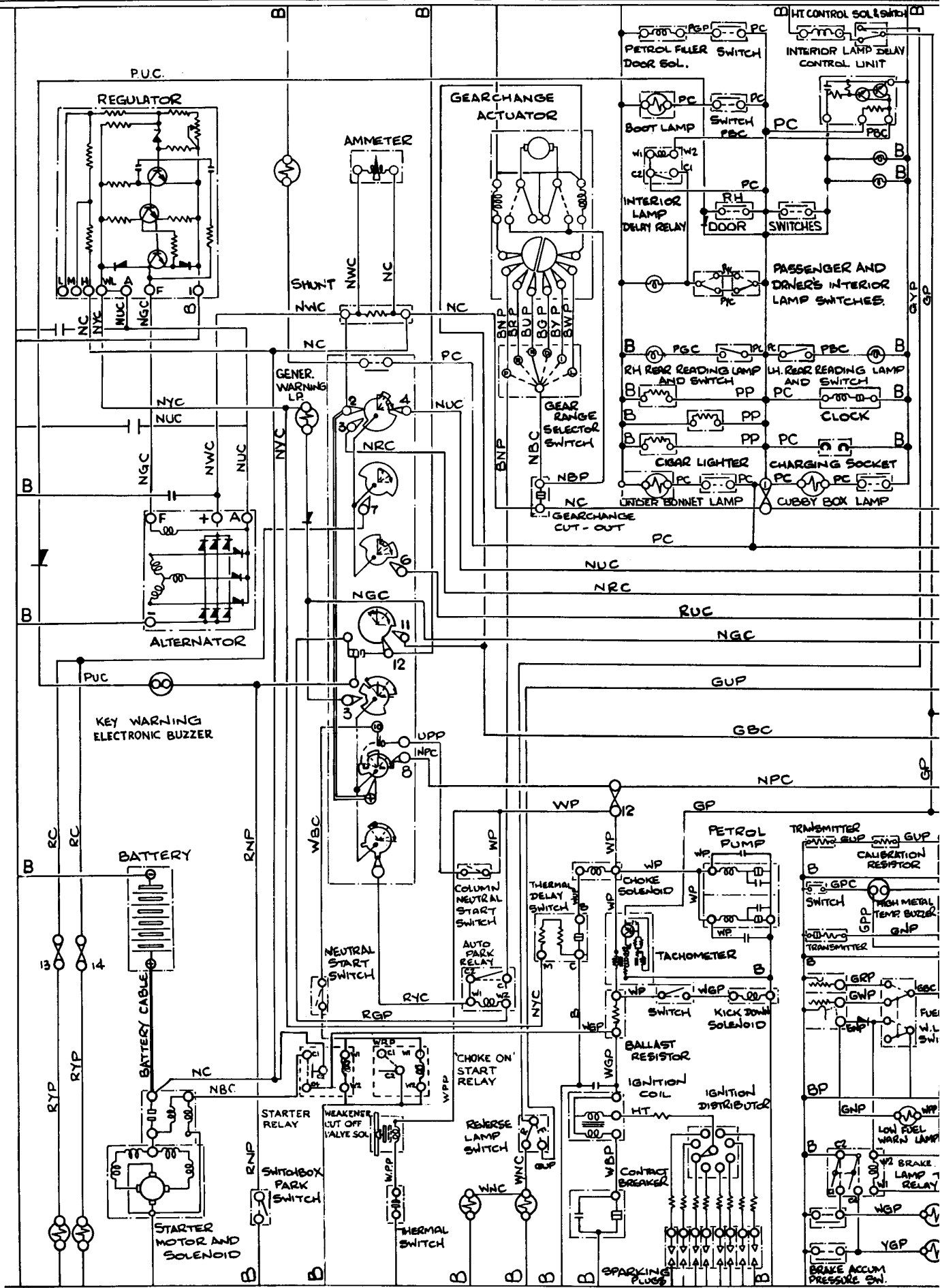

LH FOGLAMPS RH FOGLAMPS BATTERY STARTER WEAKENER CUT-OFF VALVE REVERSE LAMPS IGNITION STOP & WARNING LAMP GAUGES, HIGH METAL

ENGINE SOCKET

ELECTRICALLY OPERATED SEATS

ELECTRICAL WINDOW LIFTS

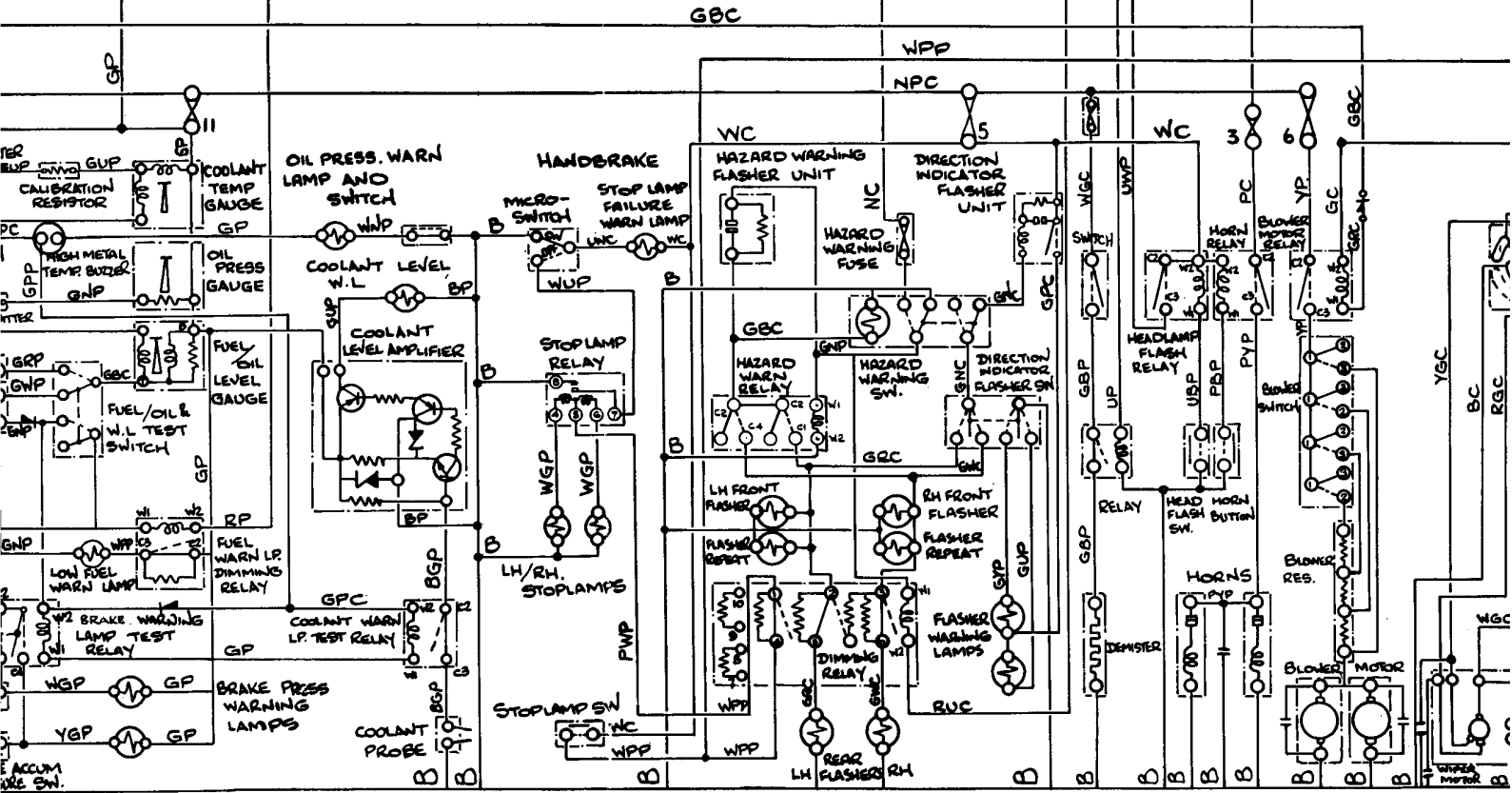
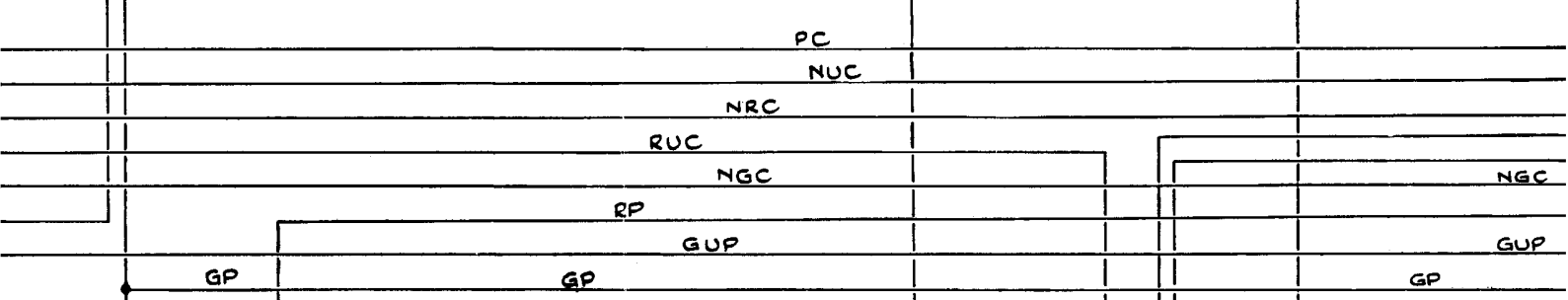
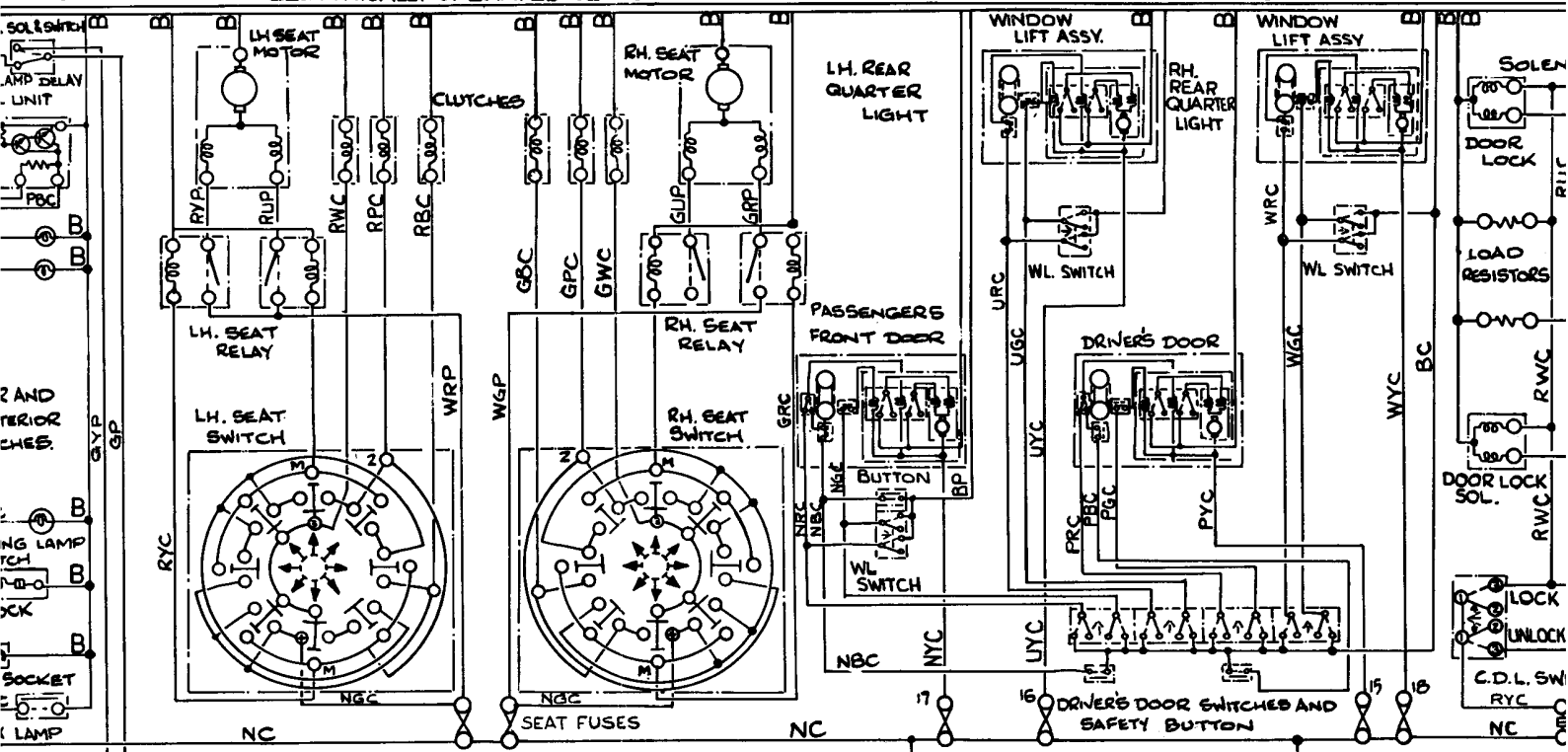

WARNING LAMPS FUEL, OIL PRESSURE, WATER TEMP, HIGH METAL TEMP. BUZZER, COOLANT PROBE

DIRECTION INDICATORS HAZARD WARNING

REAR WINDOW DEMISTER

HORNS

BLOWERS WINDSCREEN (INCLUDING)

CENTRALISED DOOR & BOOT LID LOCKING

HEADLAMPS

SIDELAMPS

PANEL LAMPS

JMORS SPEED CONTROL

AIR CONDITIONING

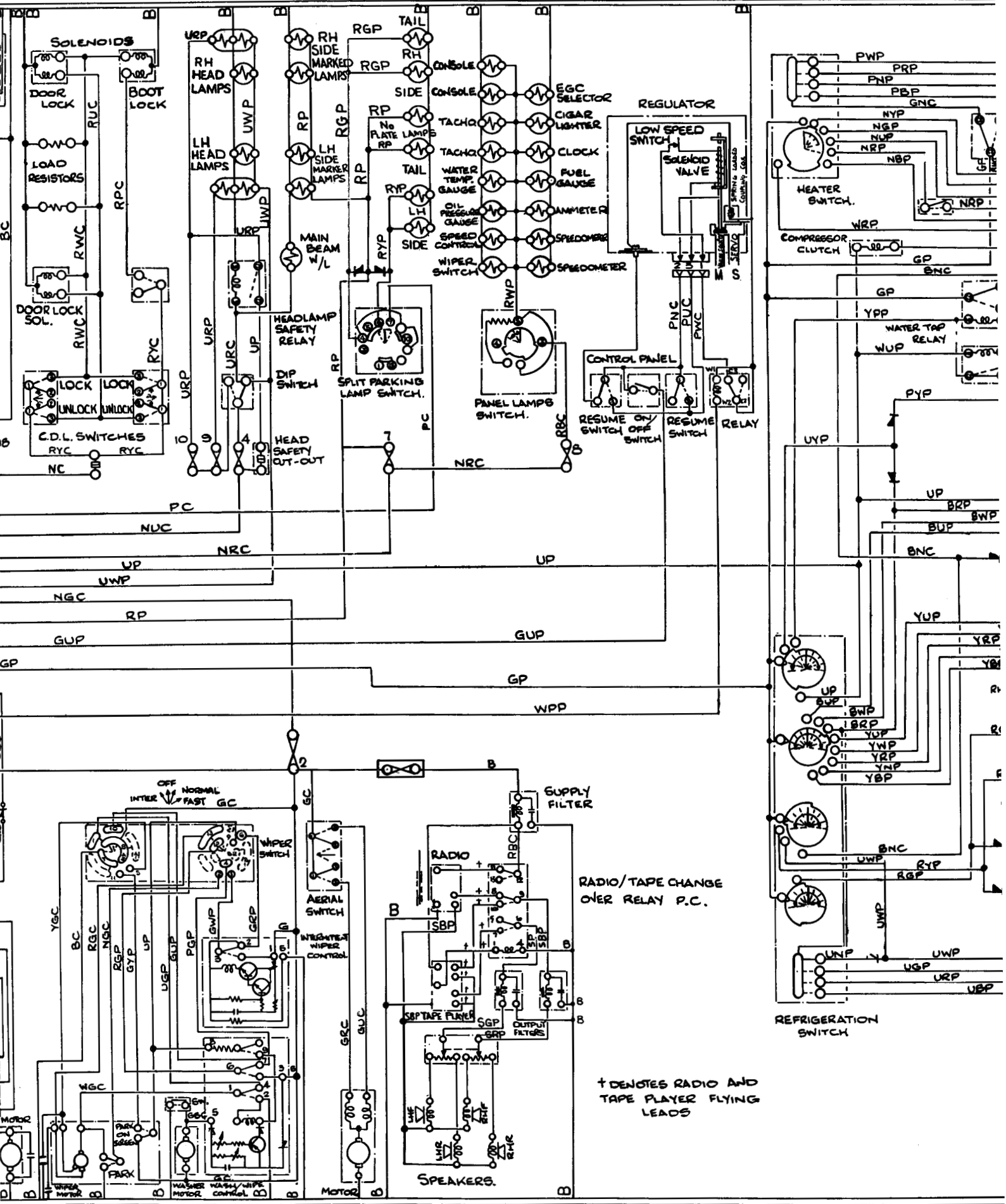

WIPERS WINDSCREEN WIPER & WASHER (INCLUDING INTERMITTENT OPERATION)

AERIAL RADIO & TAPE PLAYER MONO RADIO STEREOTAPE

† DENOTES RADIO AND TAPE PLAYER FLYING LEADS

DOOR
KING

HEADLAMPS SIDELAMPS PANEL LAMPS JMORS SPEED CONTROL AIR CONDITIONING SYSTEM

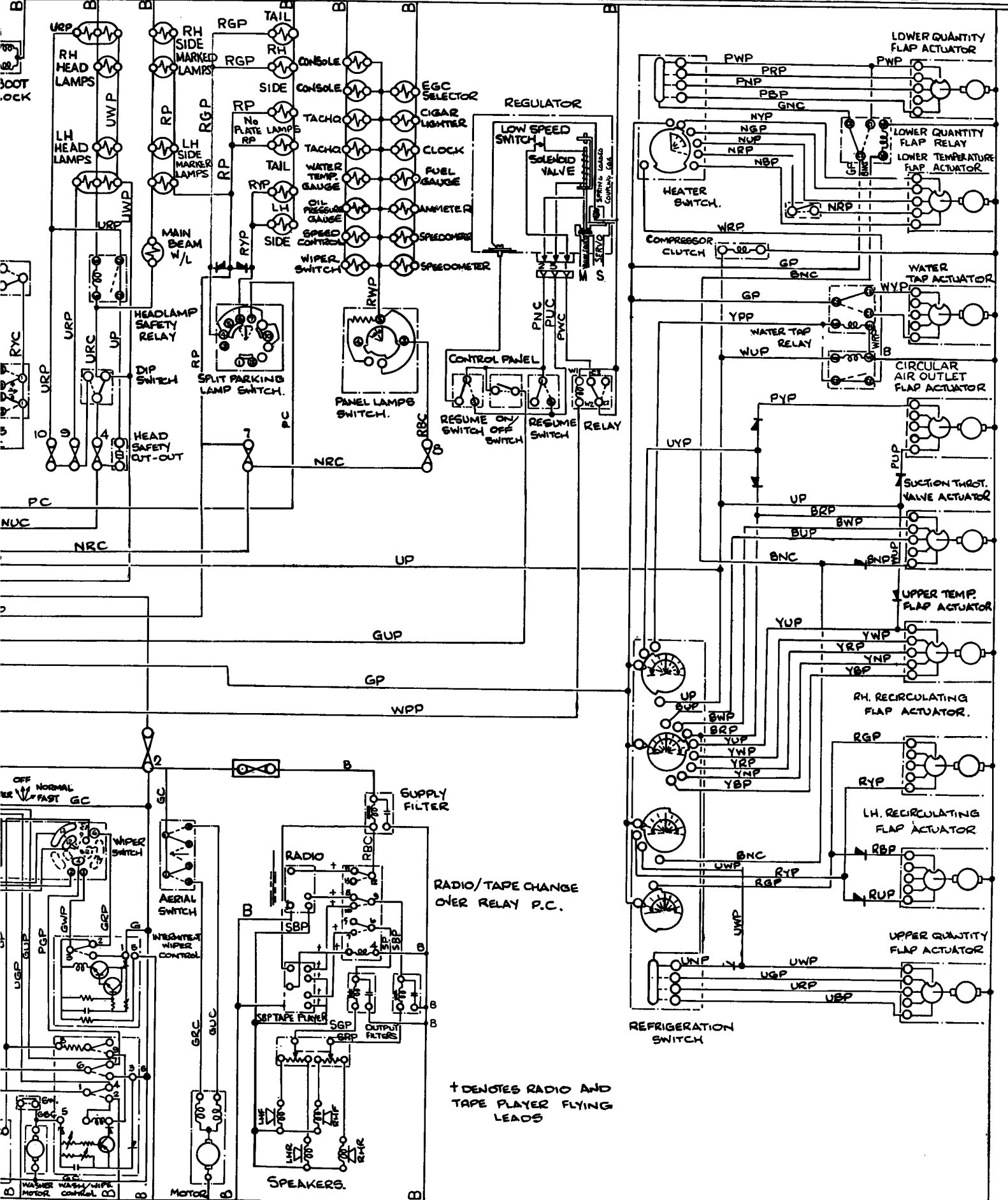

WIPER & WASHER (INTERMITTENT OPERATION) AERIAL RADIO & TAPE PLAYER MONO RADIO STEREO TAPE

THEORETICAL WIRING DIAGRAM

Sheet 6

For
Rolls-Royce Corniche Convertible
and
Bentley Corniche Convertible

**LEFT-HAND DRIVE CARS FOR COUNTRIES
OTHER THAN USA AND CANADA FROM
CAR SERIAL NUMBER 16214**

T.S.D. Publication 4051

"© Rolls-Royce Motors Limited 1974"

"This document is the property of Rolls-Royce Motors Limited and may not be copied or communicated to a third party or used for any purpose other than that for which it is supplied without the express written authority of Rolls-Royce Motors Limited."

"Whilst the information in this document given in good faith based upon the latest knowledge available to Rolls-Royce Motors Limited, Rolls-Royce Motors Limited gives no warranty or representation concerning such information, and such information must not be taken as establishing any contractual or other commitment on the part of Rolls-Royce Motors Limited."

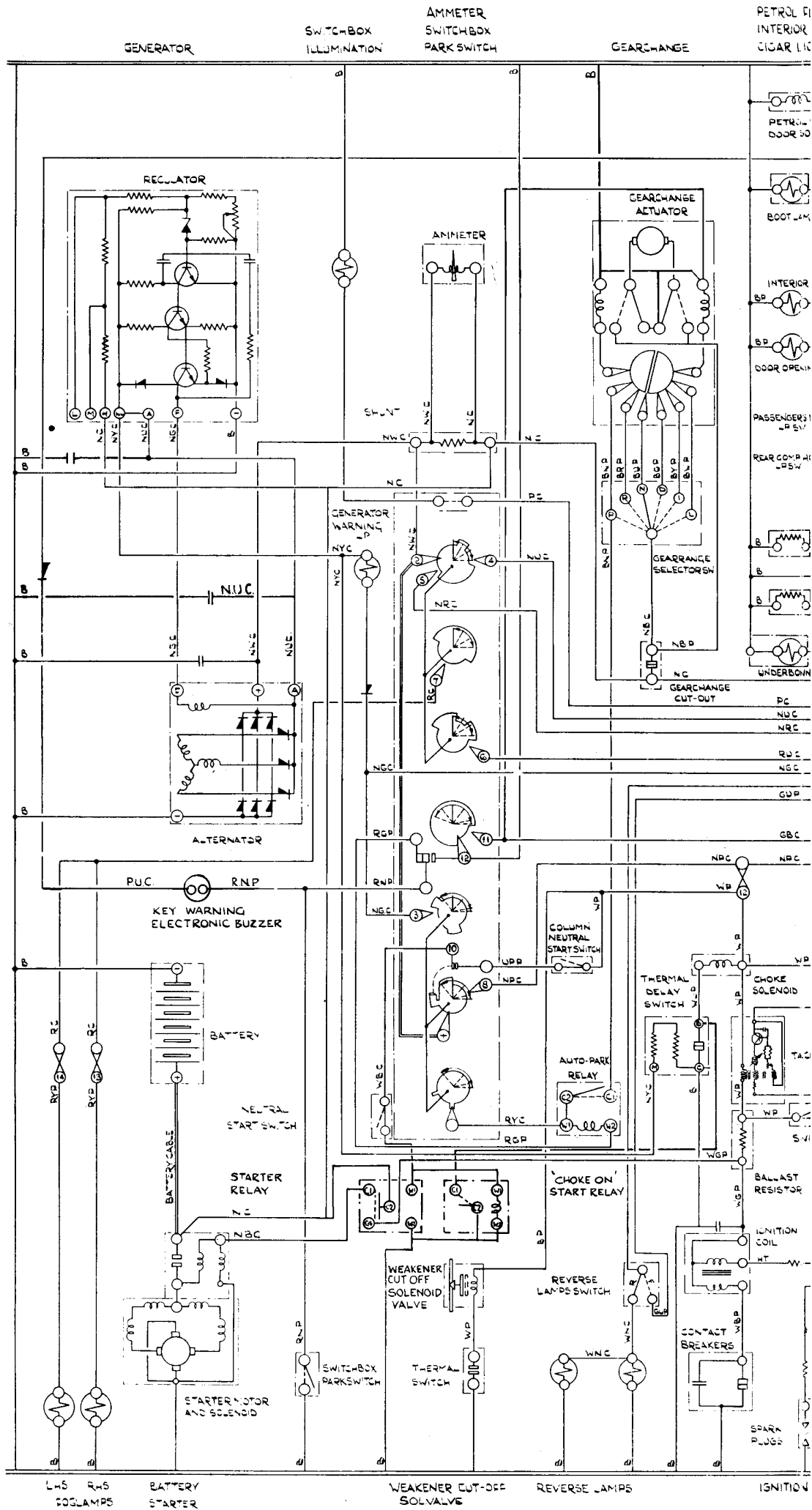

GENERATOR

SWITCHBOX ILLUMINATION

AMMETER SWITCHBOX PARK SWITCH

GEARCHANGE

PETROL INTERIOR CIGAR LIGHTS

LHS RHS BATTERY SOGLAMPS STARTER

WEAKENER CUT-OFF SOLVALVE

REVERSE LAMPS

IGNITION

FUEL FILLER DOOR
 REAR LAMPS
 CIGAR LIGHTERS

HEIGHT CONTROL
 CLOCK
 CHARGING SOCKET

ELECTRICALLY OPERATED SEATS

ELECTRIC WINDOWS

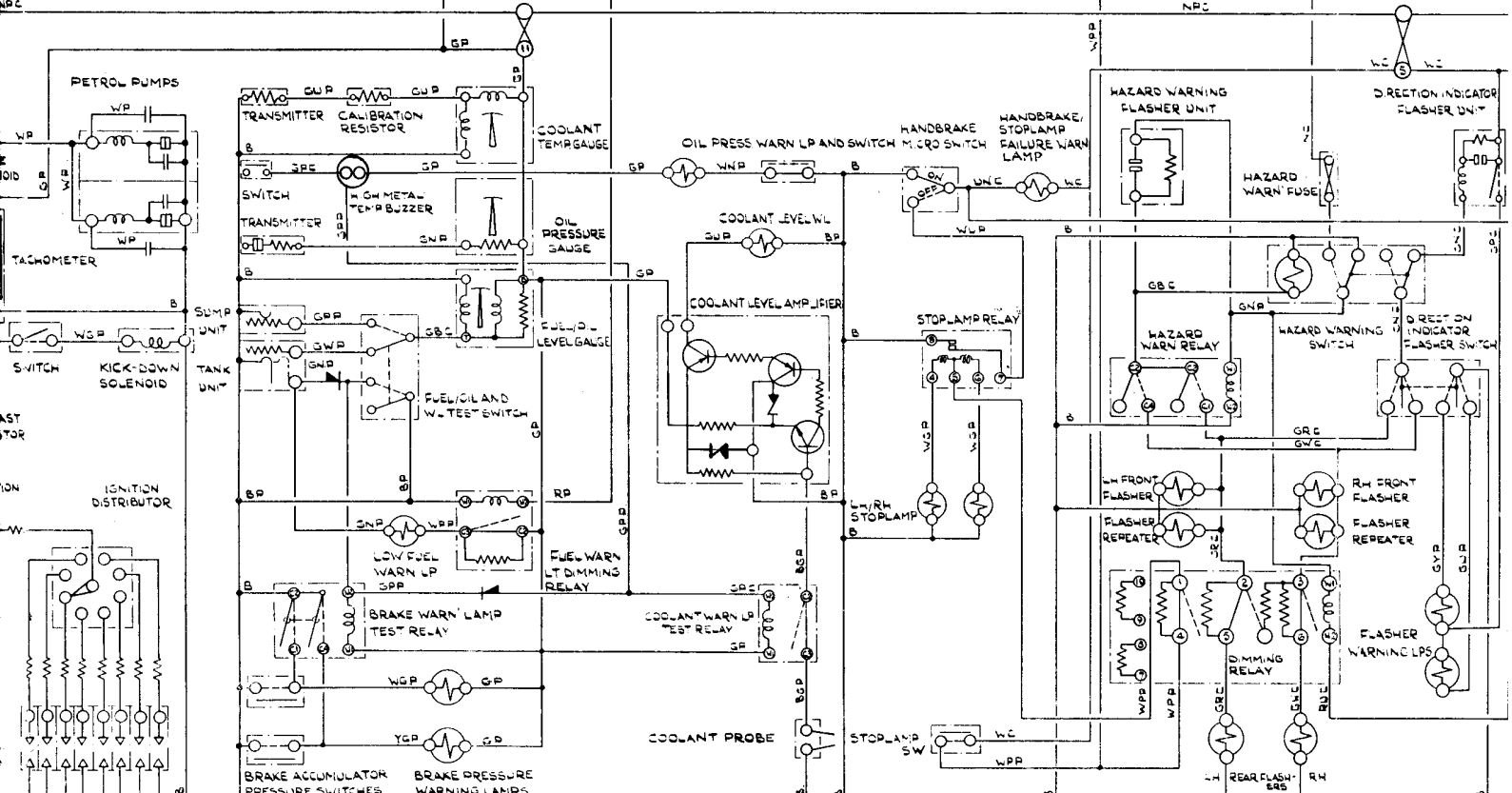
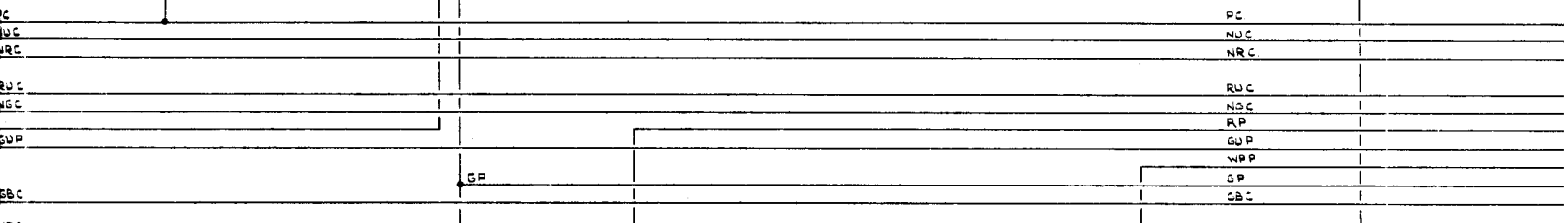
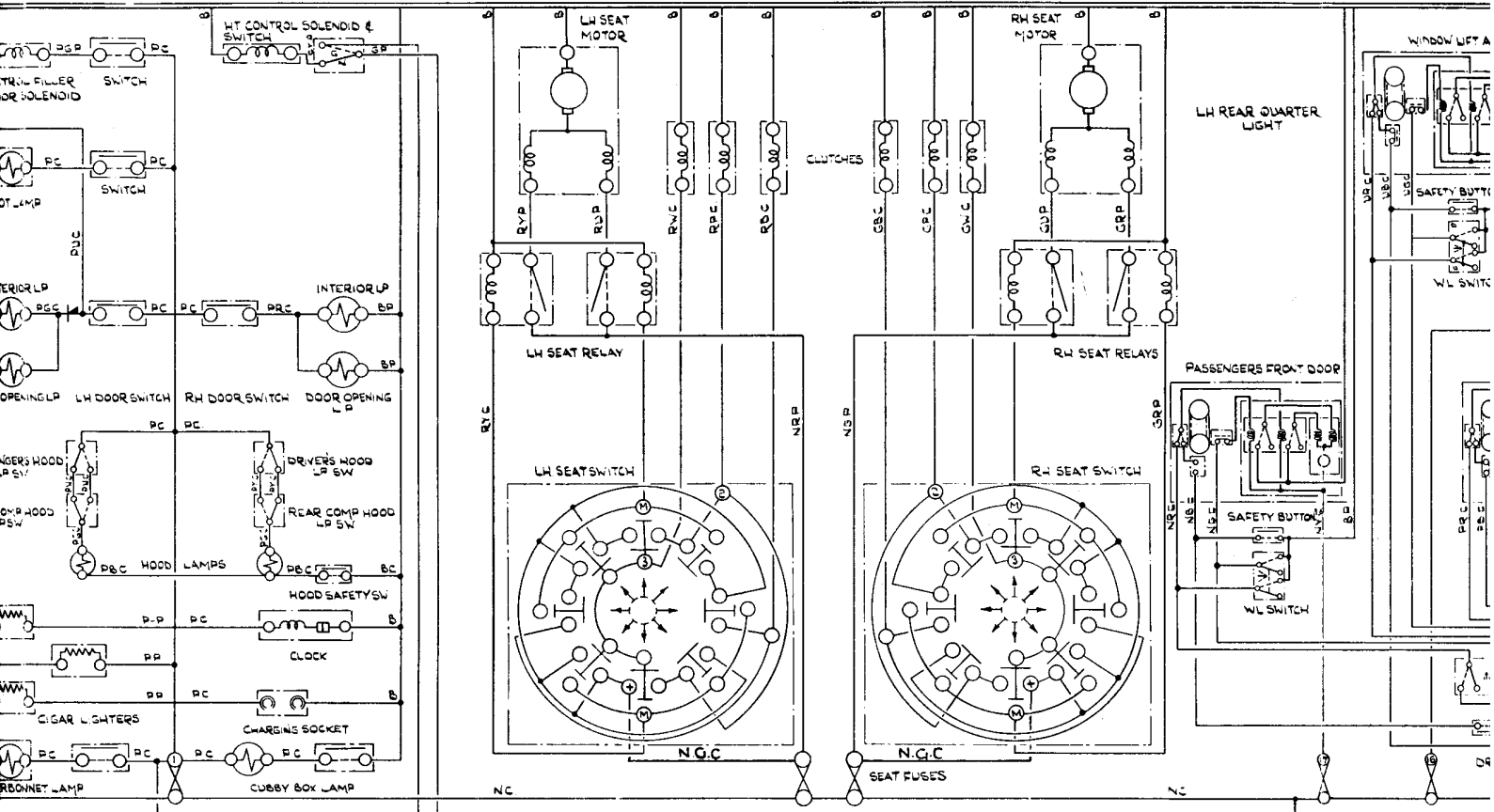

STOPLAMPS WARNING LAMPS FUEL-OIL PRESSURE WATER TEMP
 GAUGES HIGH METAL TEMPERATURE BUZZER COOLANT PROBE

DIRECTION INDICATORS HAZARD WARNING

ELECTRIC WINDOW LIFTS

CENTRALISED DOOR & BOOT LID LOCKING

HEADLAMPS

SIDELAMPS

PANEL LAMPS

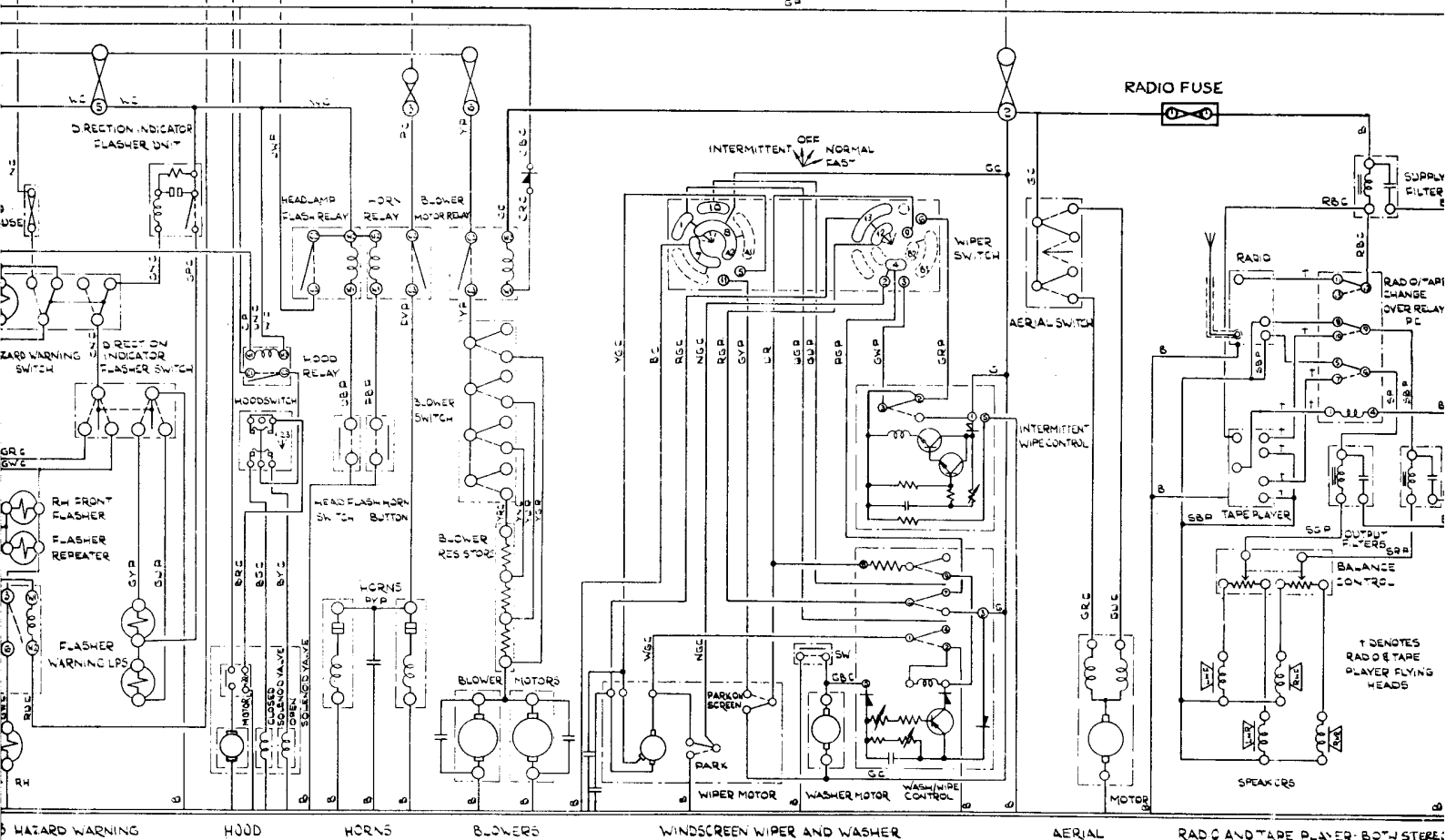
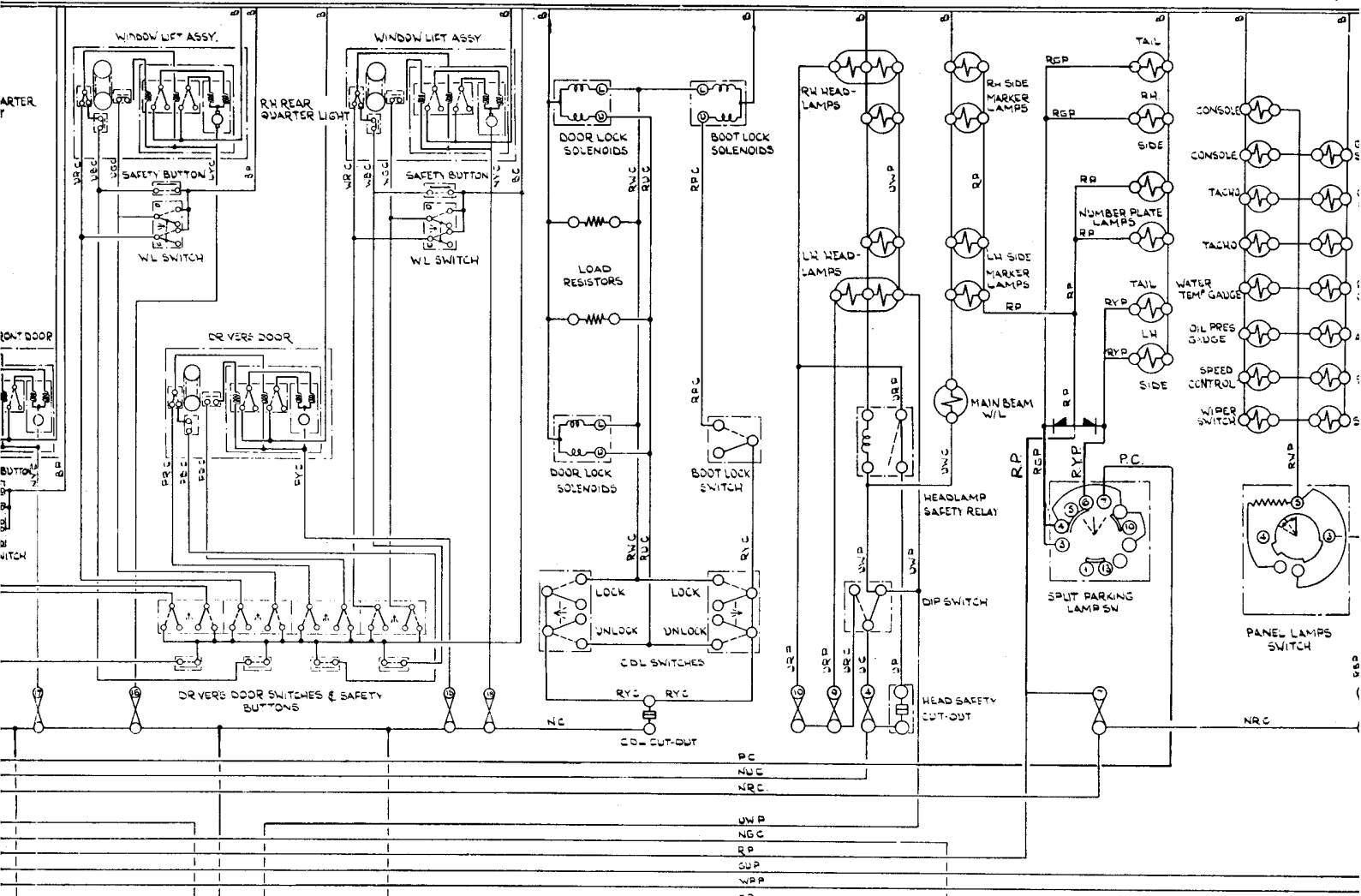

SIDLAMPS

PANEL LAMPS

JMORS SPEED CONTROL (IF FITTED)

AIR CONDITIONING UNIT SYSTEM

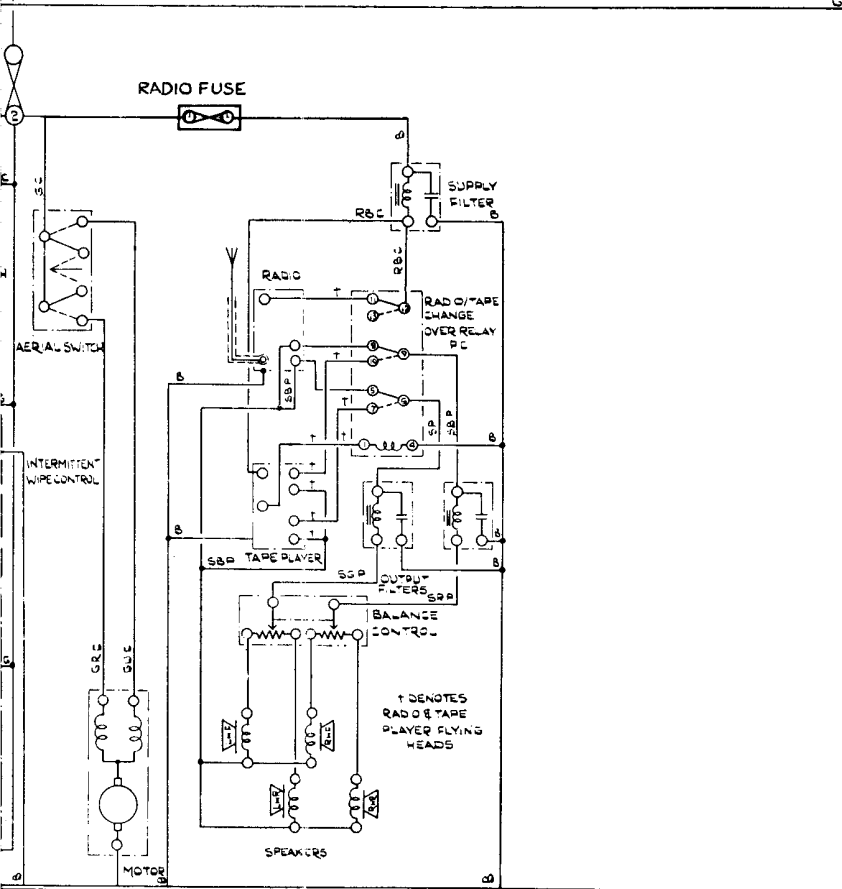
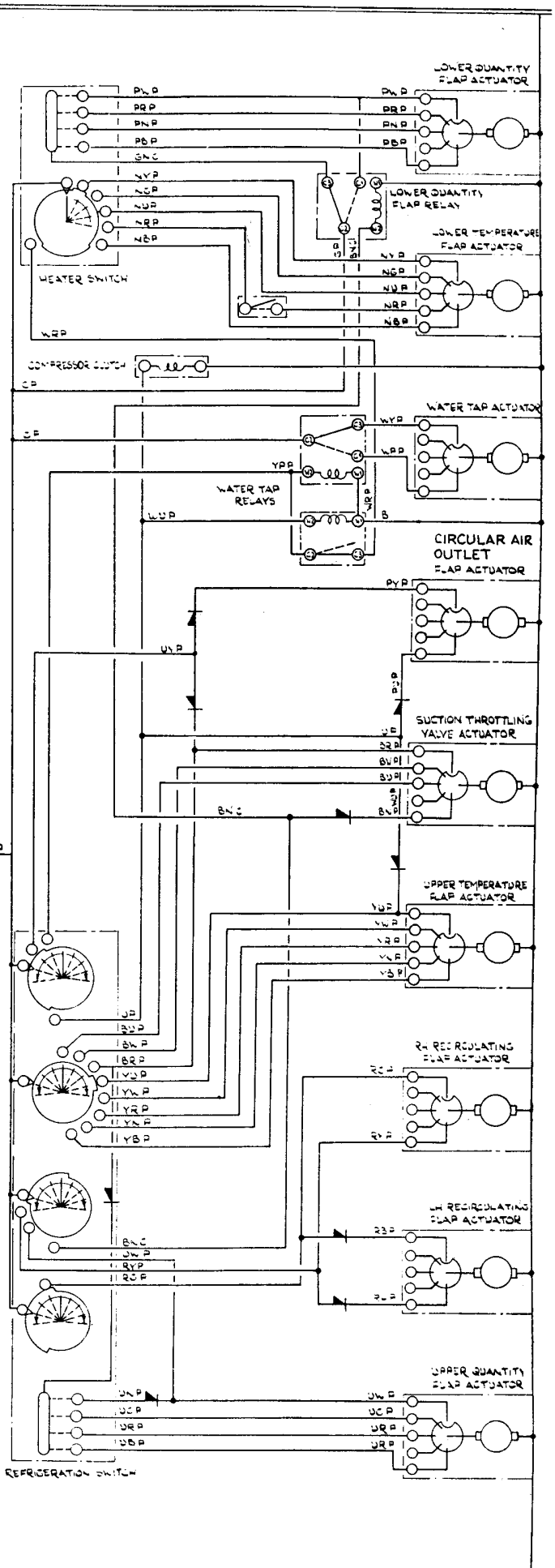
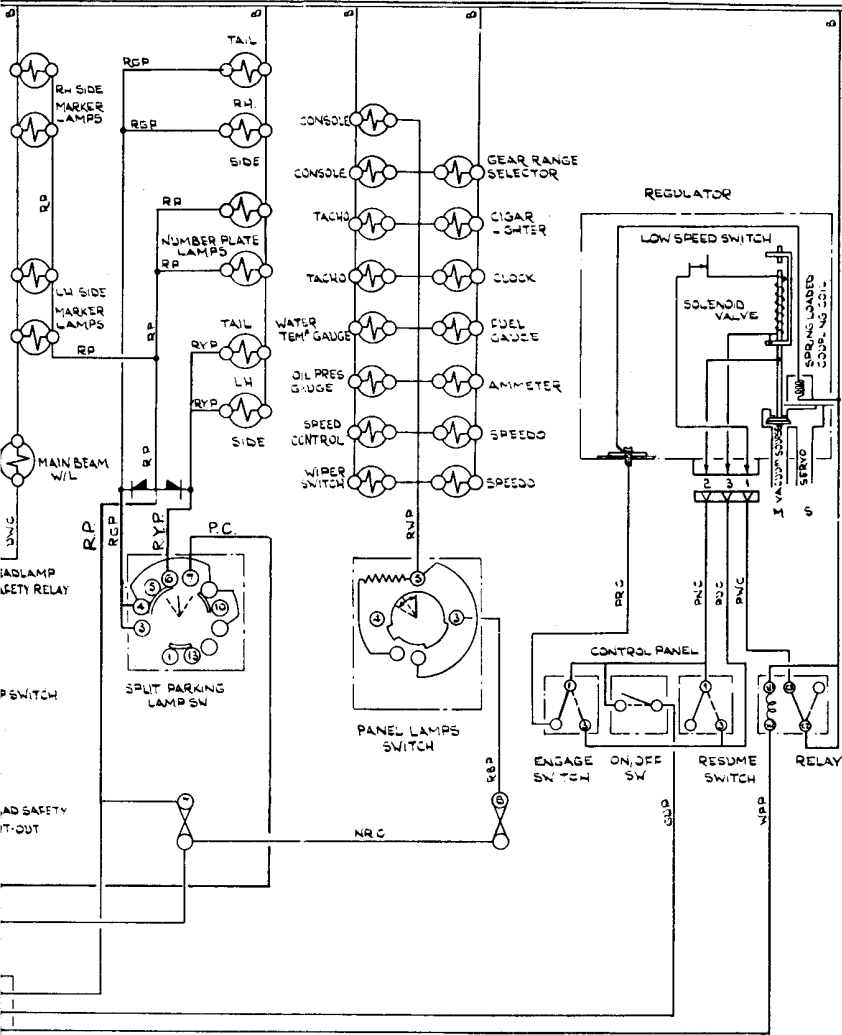

THEORETICAL WIRING DIAGRAM

Sheet 7

For
Rolls-Royce Corniche Convertible
and
Bentley Corniche Convertible

**LEFT-HAND DRIVE CARS FOR USA AND
CANADA FROM CAR SERIAL NUMBER
16214**

T.S.D. Publication 4053

"© Rolls-Royce Motors Limited 1974"

"This document is the property of Rolls-Royce Motors Limited and may not be copied or communicated to a third party or used for any purpose other than that for which it is supplied without the express written authority of Rolls-Royce Motors Limited."

"Whilst the information in this document given in good faith based upon the latest knowledge available to Rolls-Royce Motors Limited. Rolls-Royce Motors Limited gives no warranty or representation concerning such information, and such information must not be taken as establishing any contractual or other commitment on the part of Rolls-Royce Motors Limited."

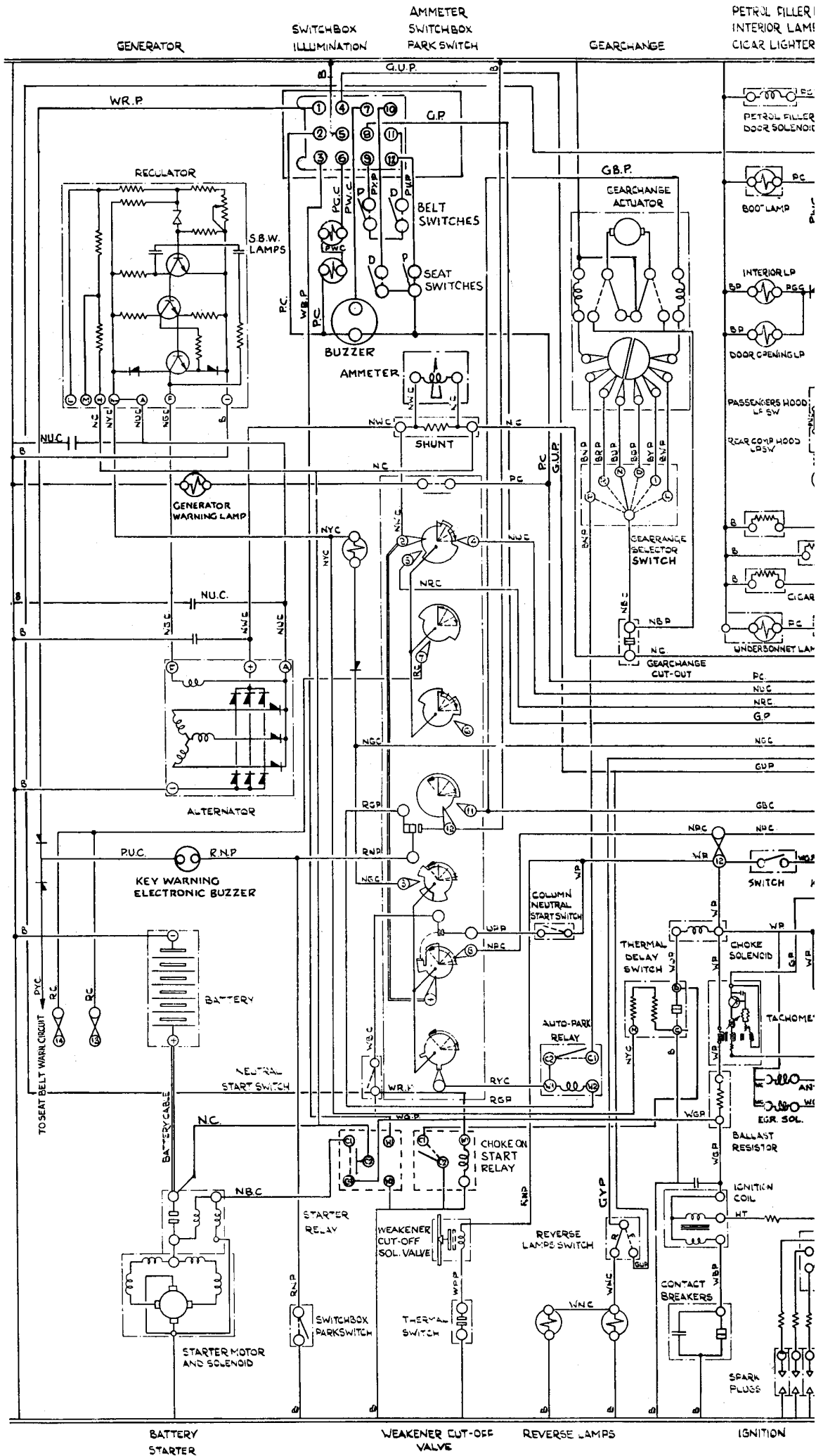

BATTERY STARTER

WEAKENER CUT-OFF VALVE

REVERSE LAMPS

IGNITION

PETROL FILLER DOOR
INTERIOR LAMPS
CIGAR LIGHTERS

HEIGHT CONTROL
CLOCK
CHARGING SOCKET

ELECTRICALLY OPERATED SEATS

ELECTRIC W

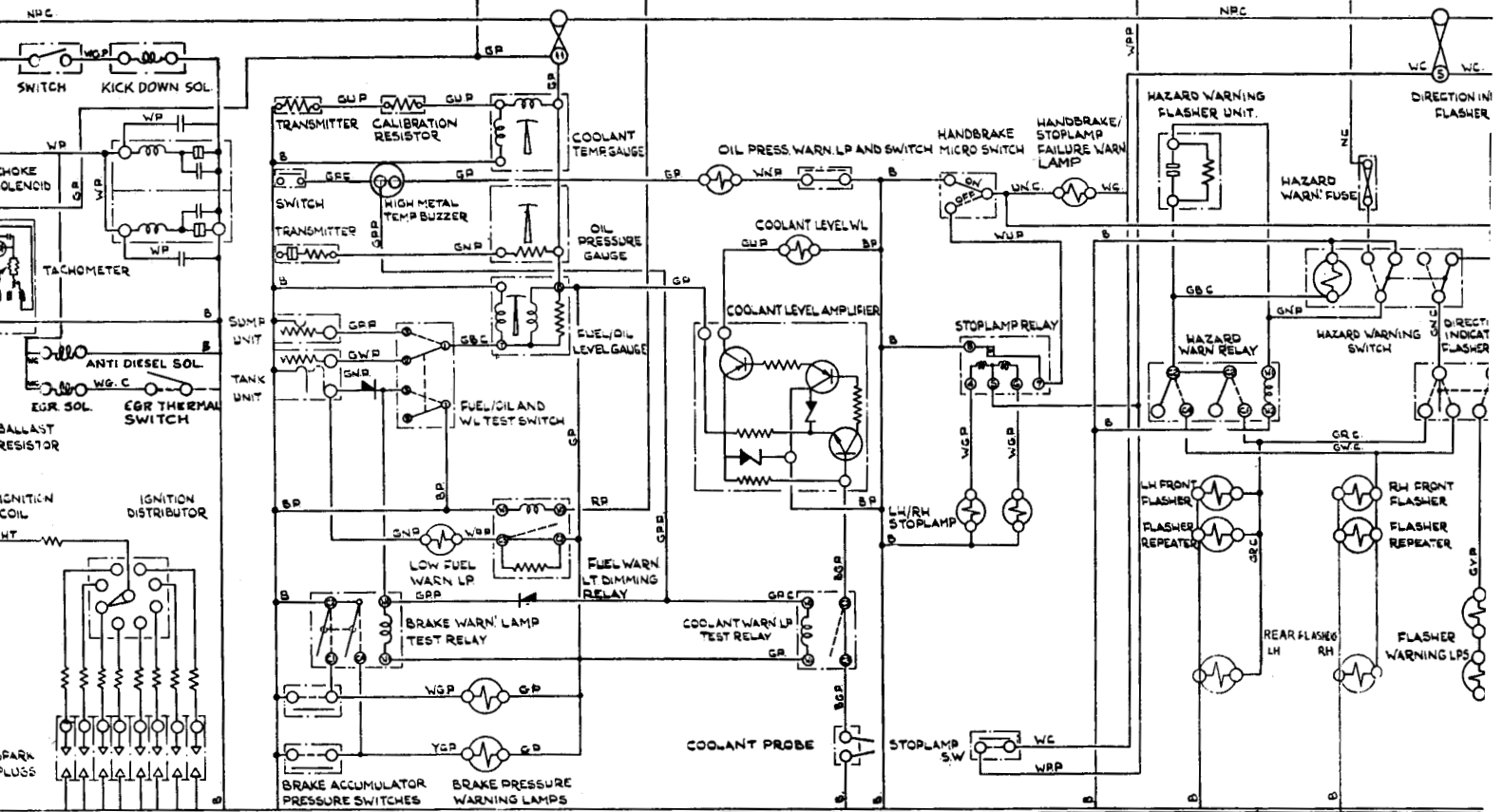
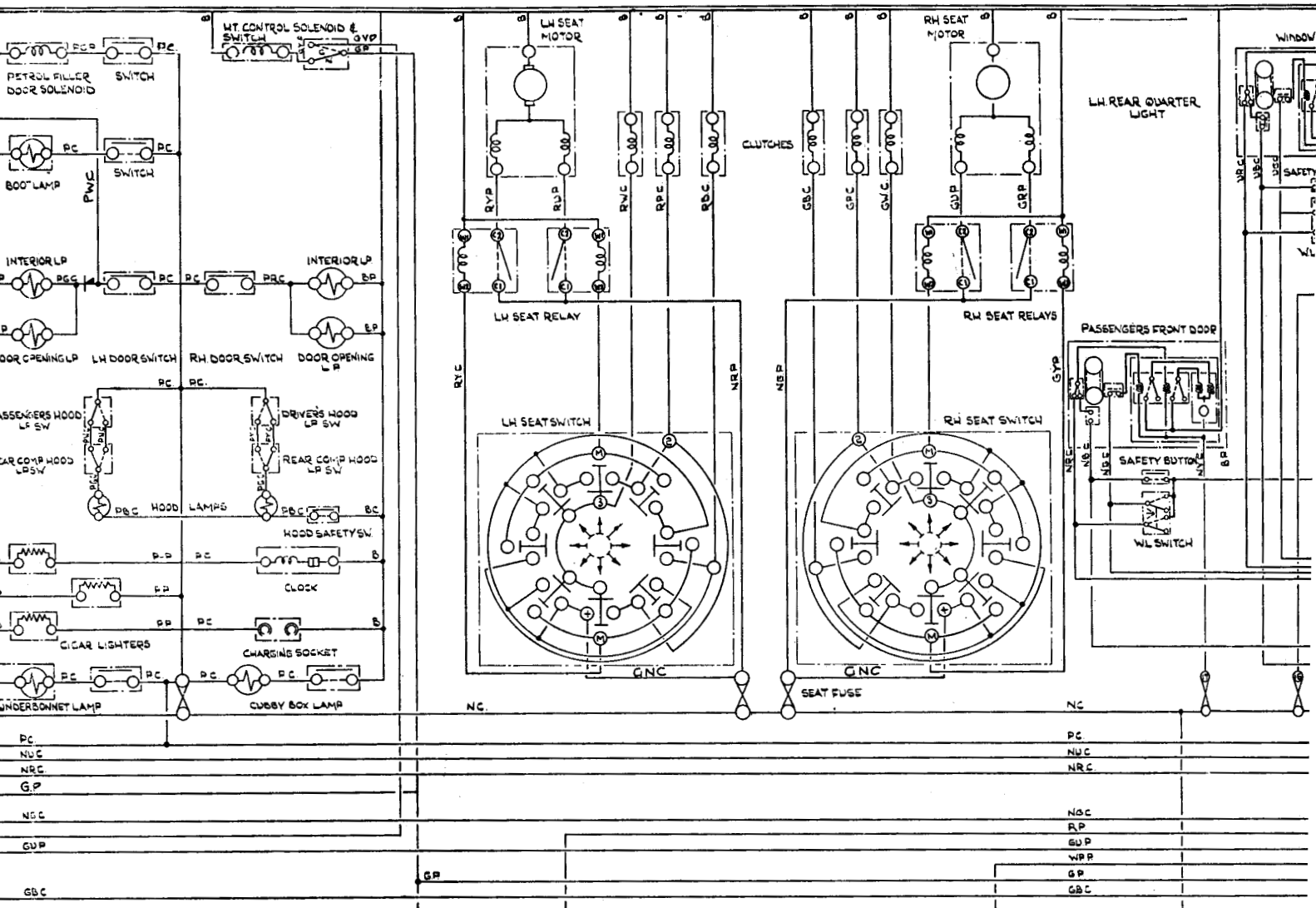

IGNITION
STOPLAMPS WARNING LAMPS FUEL-OIL PRESSURE WATER TEMP
GAUGES HIGH METAL TEMPERATURE BUZZER COOLANT PROBE
DIRECTION INDICATORS HAZARD WARNING

ELECTRIC WINDOW LIFTS

CENTRALISED DOOR & BOOT LID LOCKING

HEADLAMPS

SIDLAMPS

PANEL LAMPS

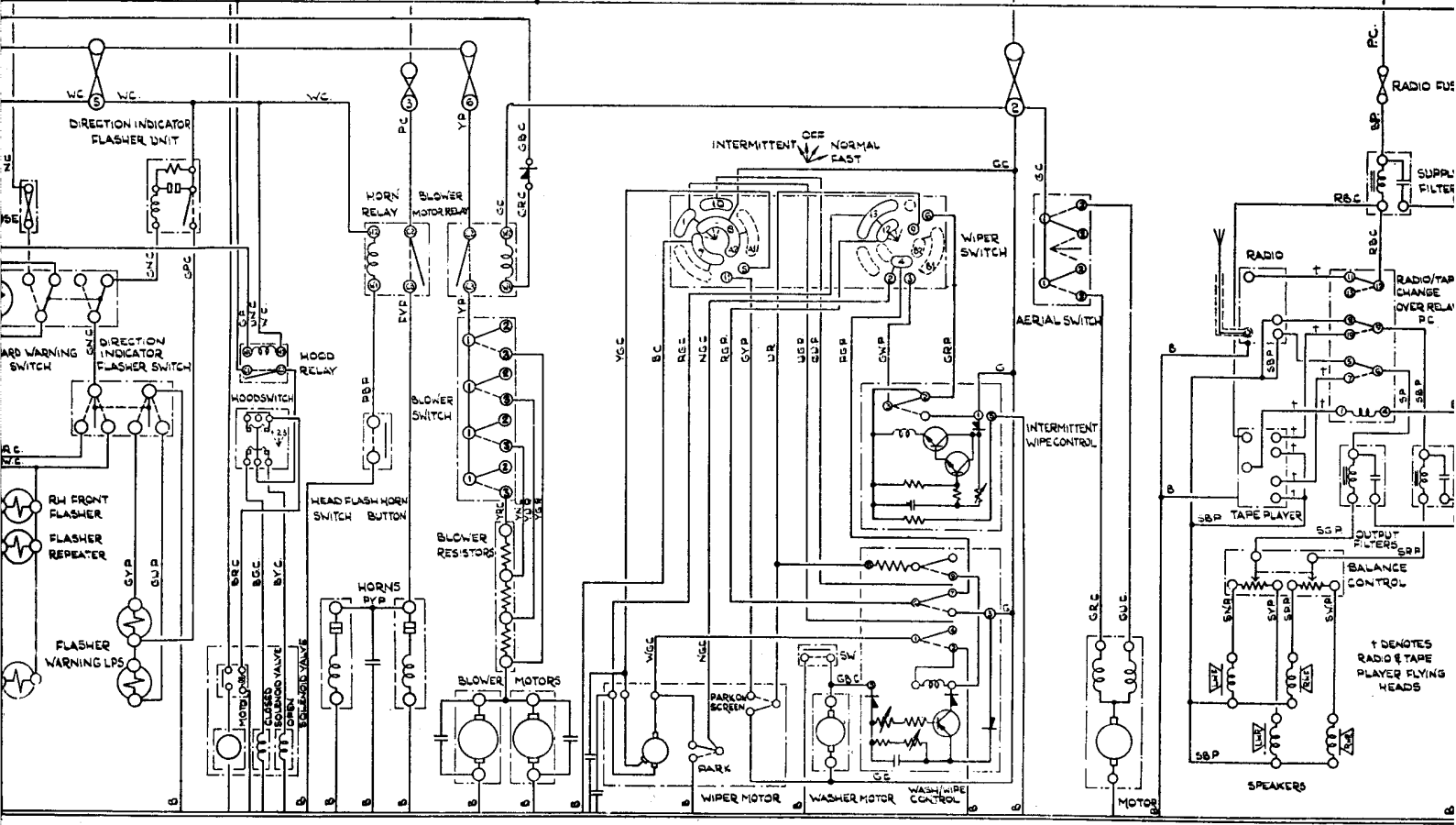
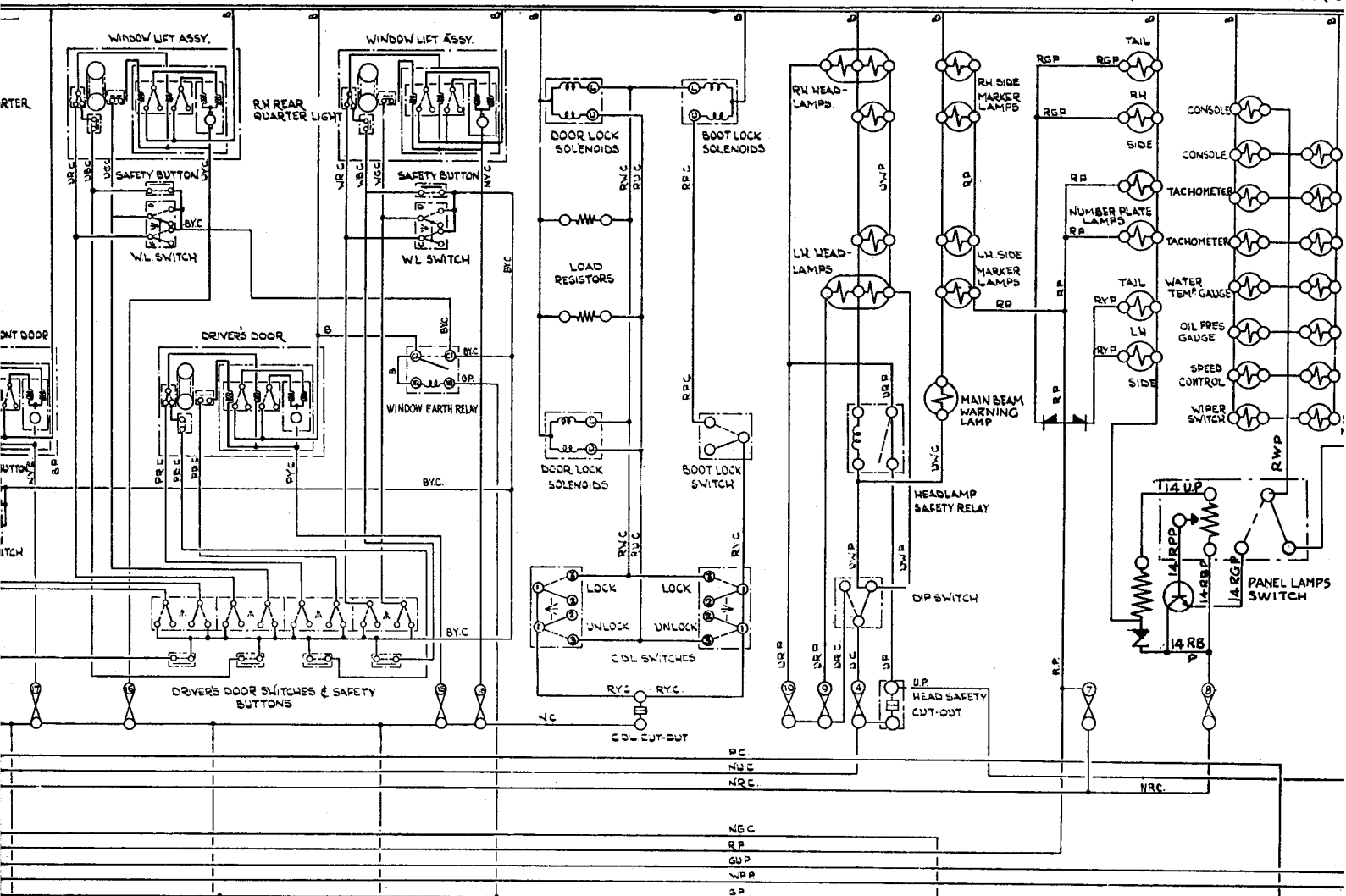

SIDELAMPS

PANEL LAMPS

JMORS SPEED CONTROL (IF FITTED)

AIR CONDITIONING UNIT SYSTEM

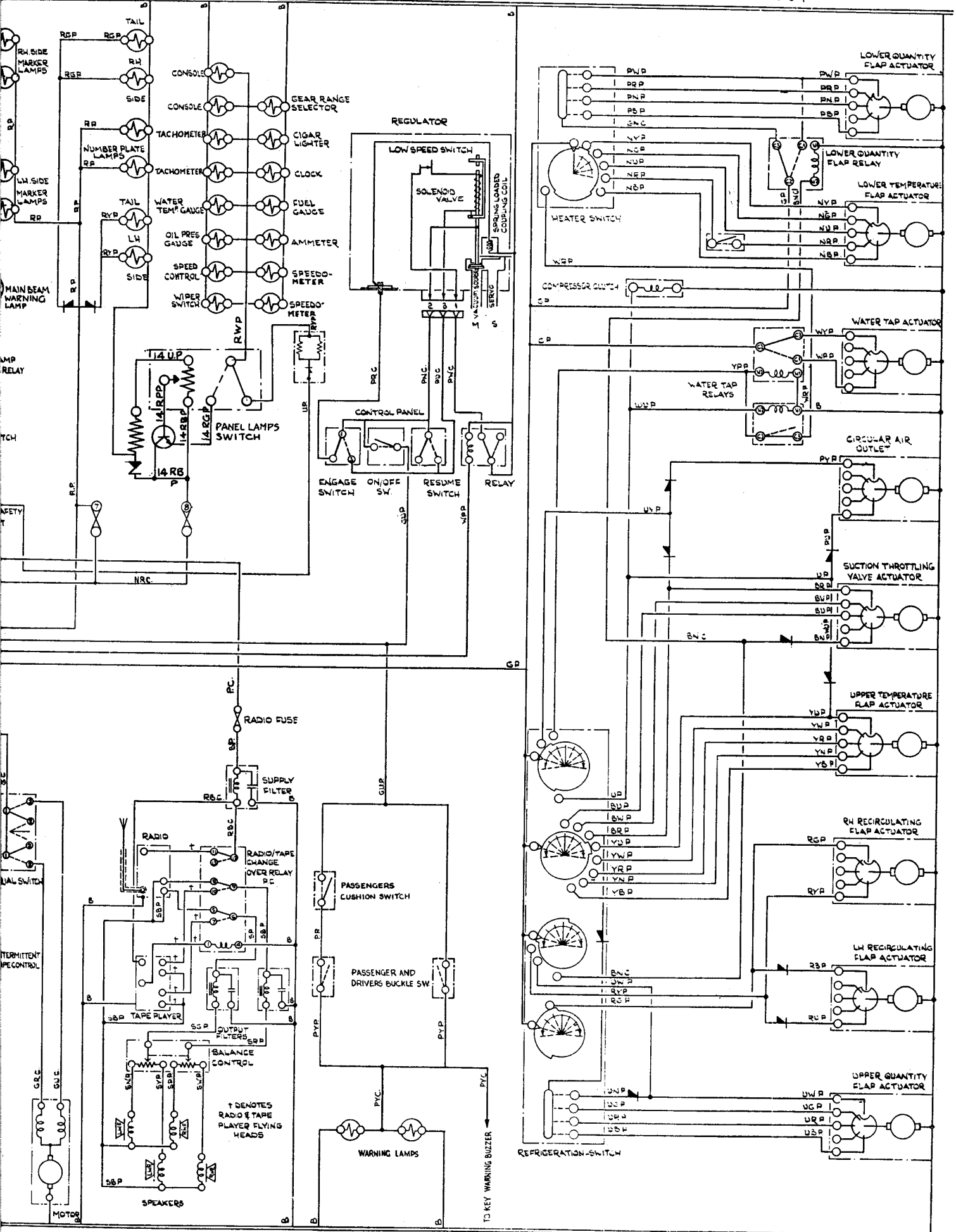

AERIAL RADIO AND TAPE PLAYER - BOTH STEREO

SEATBELT WARNING

THEORETICAL WIRING DIAGRAM

Sheet 8

For
Rolls-Royce Corniche Convertible
and
Bentley Corniche Convertible

RIGHT-HAND DRIVE CARS FROM CAR SERIAL NUMBER 16214

T.S.D. Publication 4049

"© Rolls-Royce Motors Limited 1974"

"This document is the property of Rolls-Royce Motors Limited and may not be copied or communicated to a third party or used for any purpose other than that for which it is supplied without the express written authority of Rolls-Royce Motors Limited."

"Whilst the information in this document given in good faith based upon the latest knowledge available to Rolls-Royce Motors Limited. Rolls-Royce Motors Limited gives no warranty or representation concerning such information, and such information must not be taken as establishing any contractual or other commitment on the part of Rolls-Royce Motors Limited."

PANEL LAMPS

FMORS SPEED CONTROL

AIR CONDITIONING UNIT SYSTEM

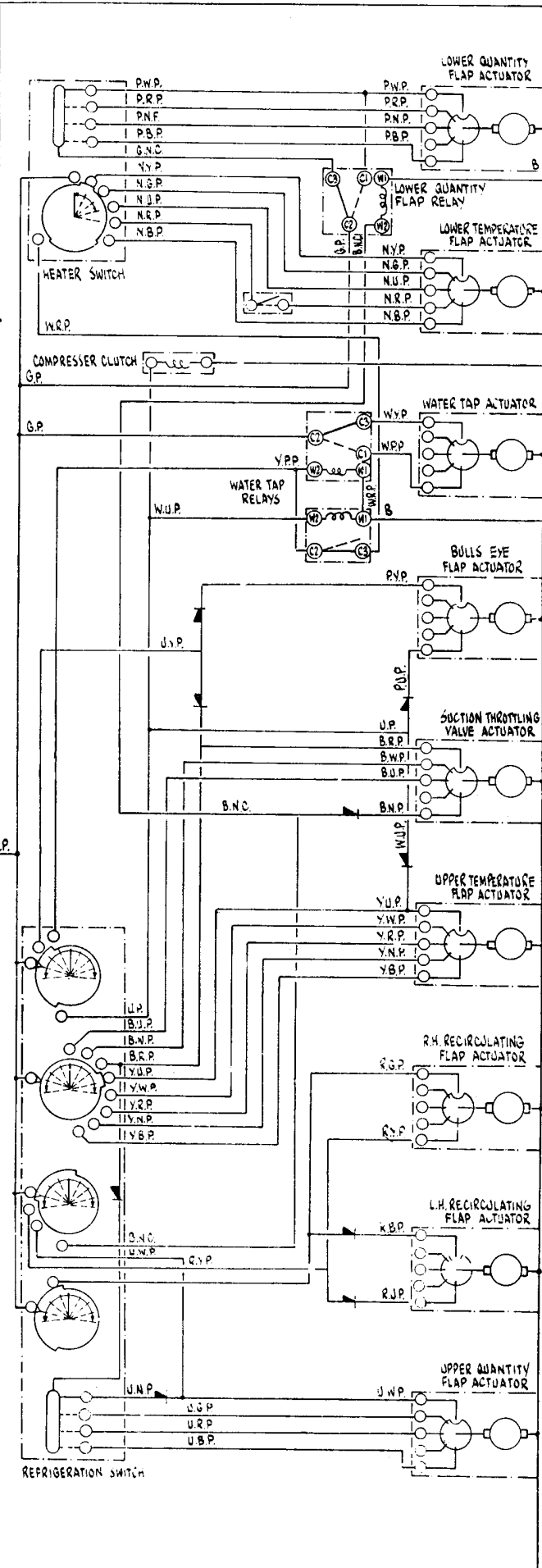
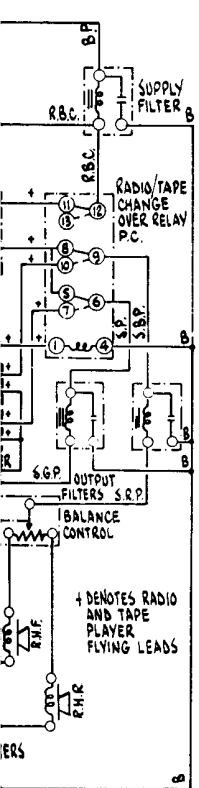
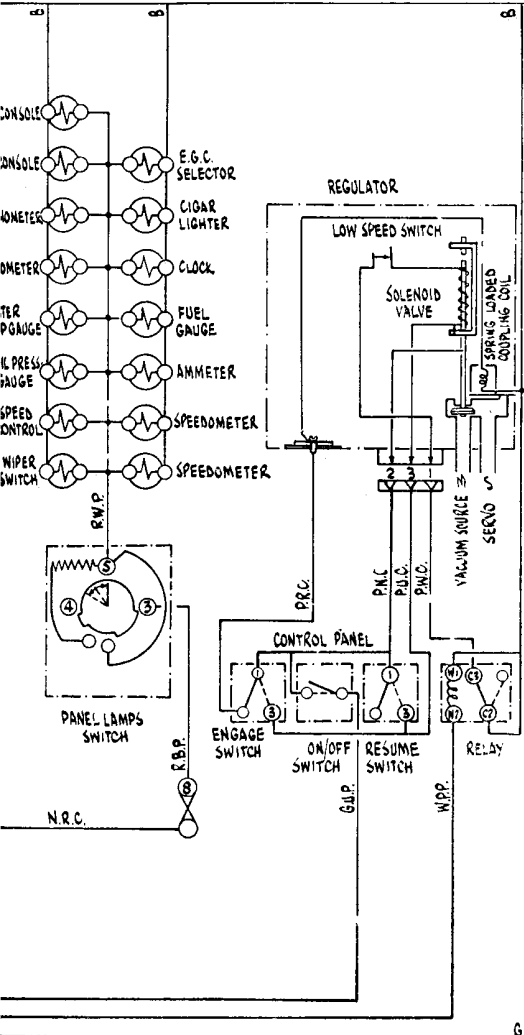

RADIO AND TAPE PLAYER AND STEREO TAPE

THEORETICAL WIRING DIAGRAM

Sheet 9

For
Rolls-Royce Silver Shadow
and
Bentley T Series

**LEFT-HAND DRIVE SALOON AND LONG
WHEELBASE NON-DIVISION CARS FOR
COUNTRIES OTHER THAN USA AND
CANADA FROM CAR SERIAL NUMBER
16214**

T.S.D. Publication 4030

"© Rolls-Royce Motors Limited 1974"

"This document is the property of Rolls-Royce Motors Limited and may not be copied or communicated to a third party or used for any purpose other than that for which it is supplied without the express written authority of Rolls-Royce Motors Limited."

"Whilst the information in this document given in good faith based upon the latest knowledge available to Rolls-Royce Motors Limited. Rolls-Royce Motors Limited gives no warranty or representation concerning such information, and such information must not be taken as establishing any contractual or other commitment on the part of Rolls-Royce Motors Limited."

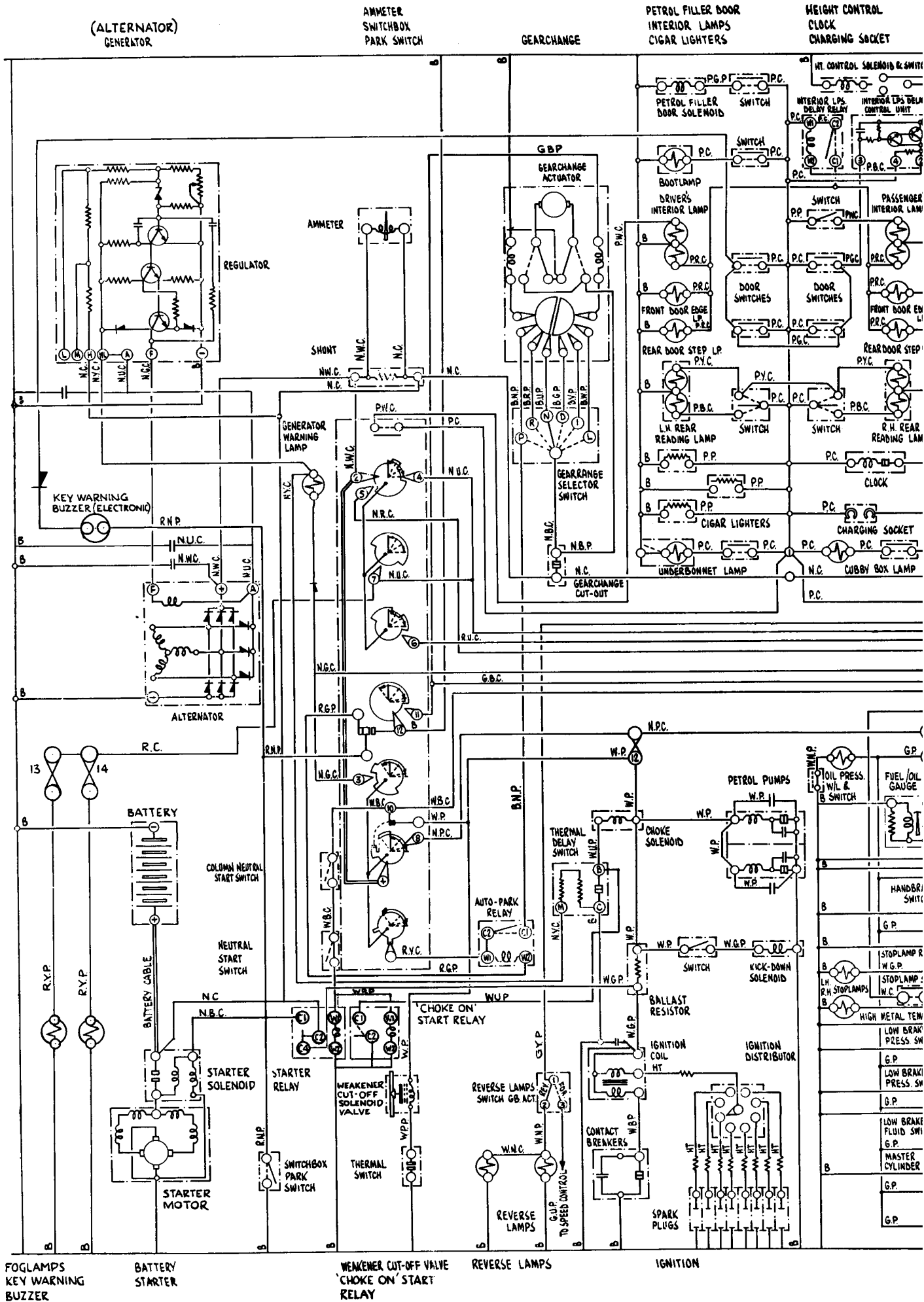

(ALTERNATOR)
GENERATOR

AMMETER
SWITCHBOX
PARK SWITCH

GEARCHANGE

PETROL FILLER DOOR
INTERIOR LAMPS
CIGAR LIGHTERS

HEIGHT CONTROL
CLOCK
CHARGING SOCKET

FOGLAMPS
KEY WARNING
BUZZER

BATTERY
STARTER

WEAKENER CUT-OFF VALVE
CHOKE ON START
RELAY

REVERSE LAMPS

IGNITION

CONTROL

12V SOCKET

ELECTRICALLY OPERATED SEATS

ELECTRIC WINDOW LIFTS WITH P.M. MOTORS

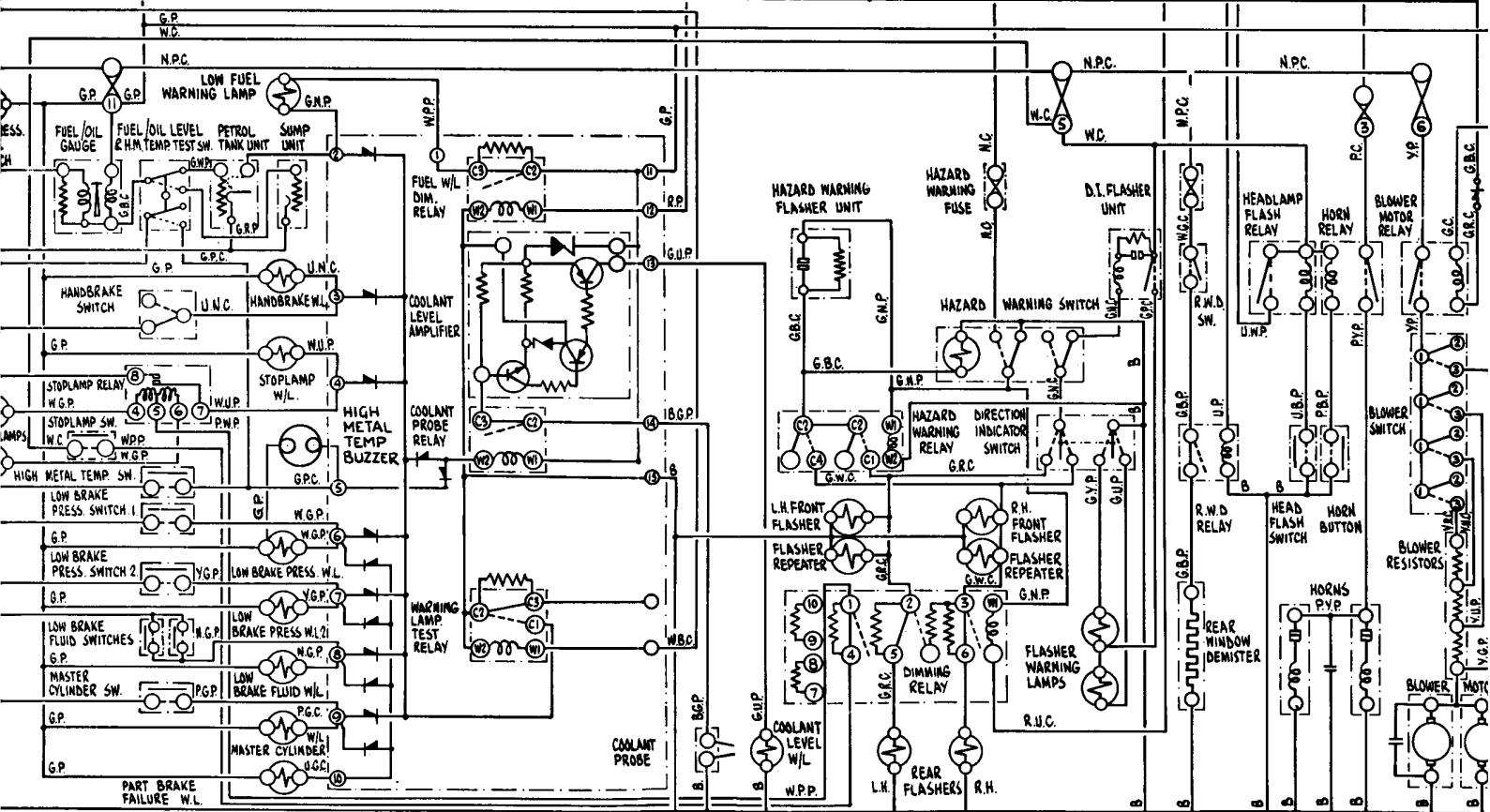
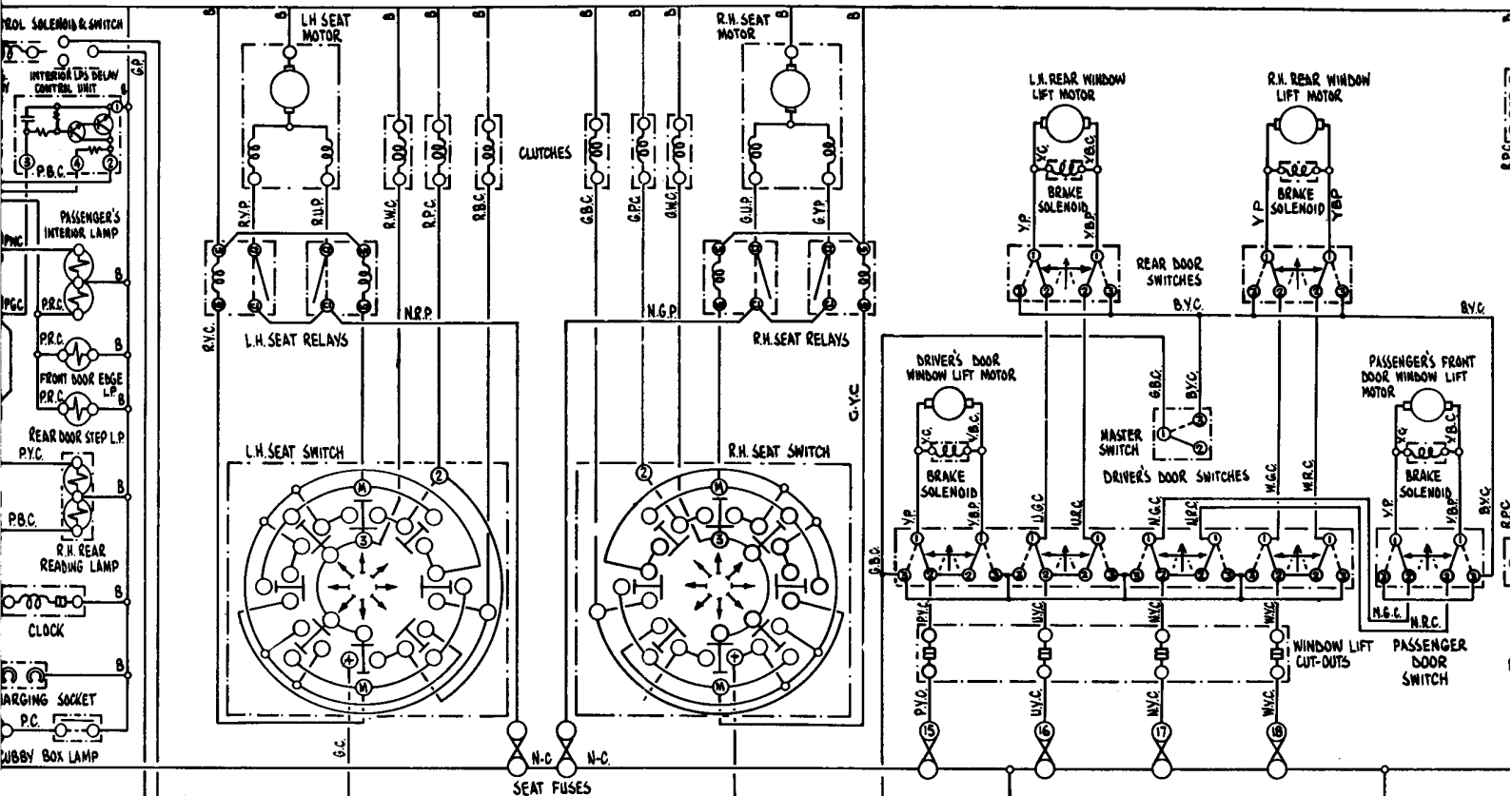

STOPLAMPS, WARNING LAMPS, FUEL GAUGE, HIGH METAL TEMPERATURE BUZZER, COOLANT PROBE.

DIRECTION INDICATORS, HAZARD WARNING

REAR WINDOW DEMISTER

HORNS

BLOWER MOTORS

CENTRALISED DOOR & BOOT LID LOCKING

HEADLAMPS

SIDELAMPS

PANEL LAMPS

AIR CONDITIONING SYSTEM

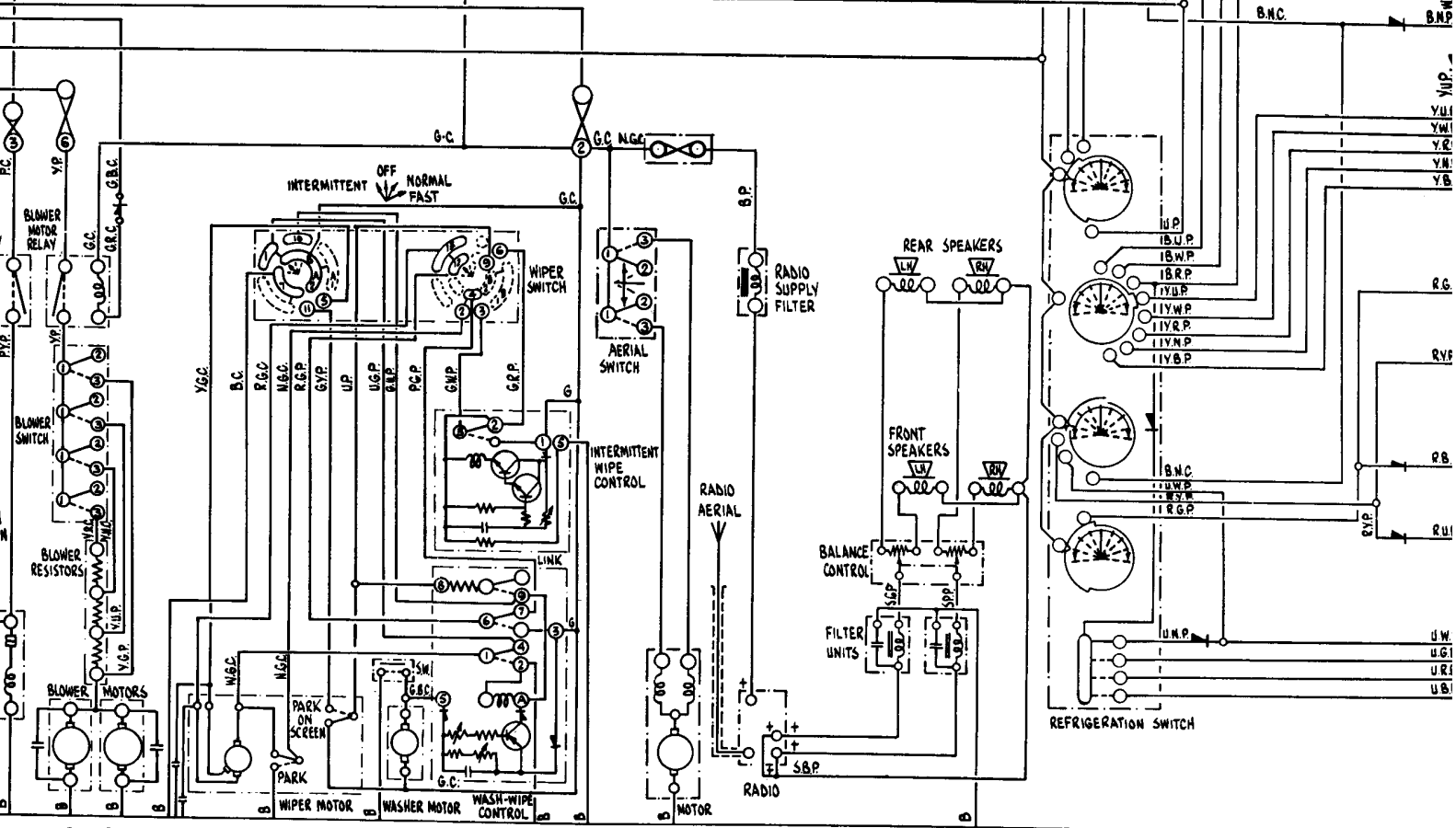
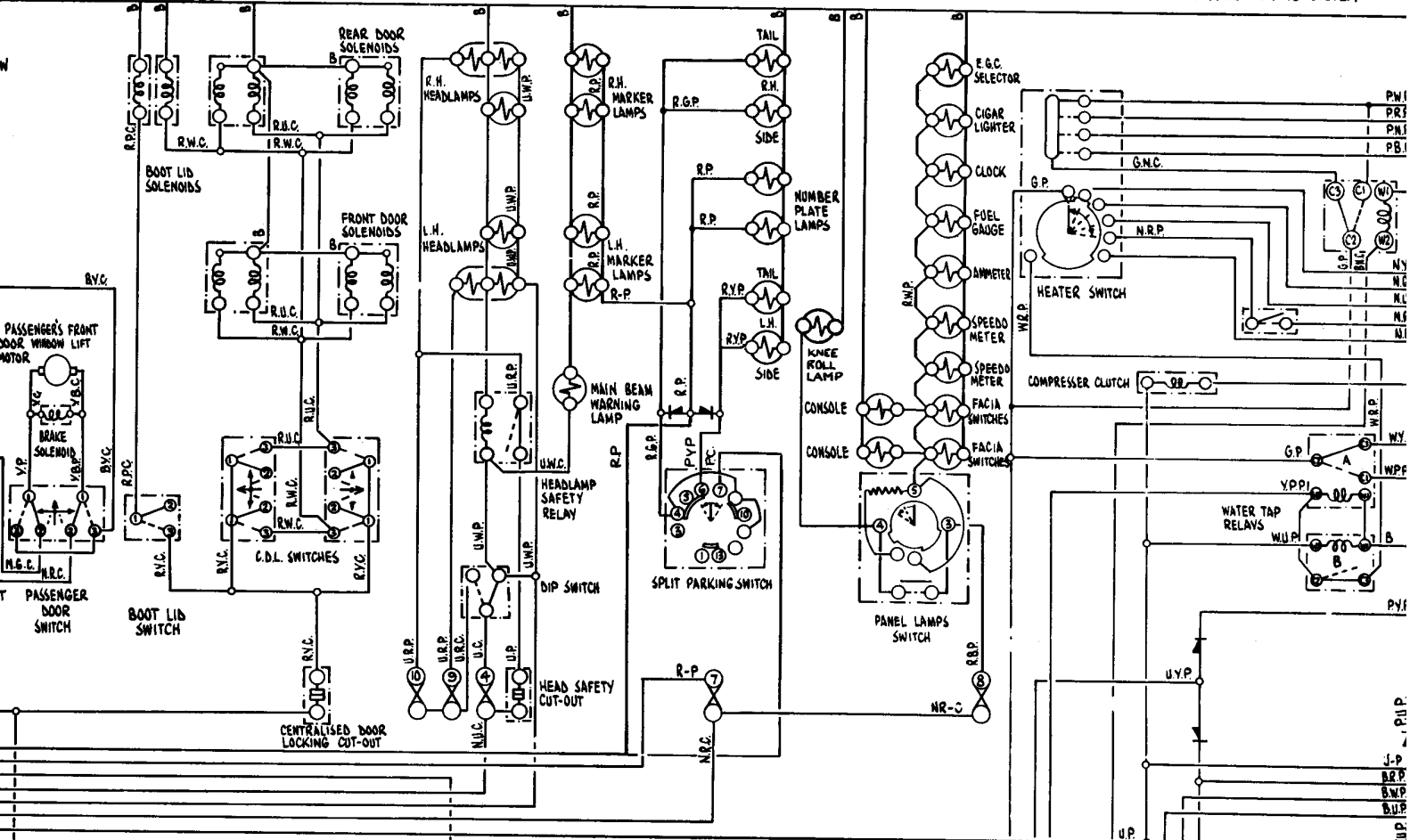

STEREO RADIO
† DENOTES RADIO FLYING LEAD

USED DOOR & BOOT LID LOCKING

HEADLAMPS

SIDELAMPS

PANEL LAMPS

AIR CONDITIONING SYSTEM

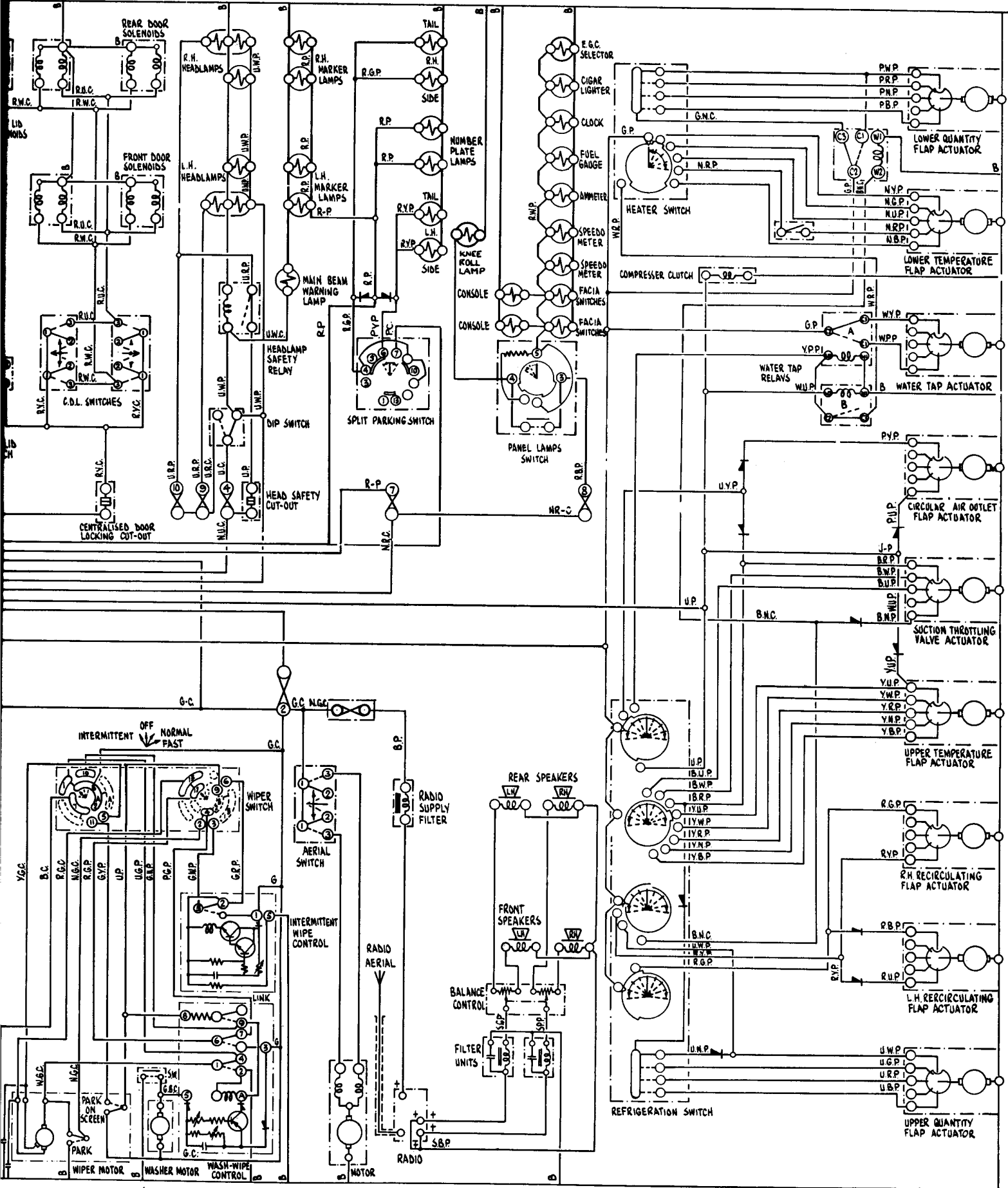

WINDSCREEN WIPER (INCLUDING INTERMITTENT OPERATION) AND WASHER

AERIAL

STEREO RADIO
+ DENOTES RADIO FLYING LEAD

THEORETICAL WIRING DIAGRAM

Sheet 10

For
Rolls-Royce Silver Shadow
and
Bentley T Series

SALOON AND LONG WHEELBASE NON-DIVISION CARS FOR USA AND CANADA FROM CAR SERIAL NUMBER 16214

T.S.D. Publication 4052

“© Rolls-Royce Motors Limited 1974”

“This document is the property of Rolls-Royce Motors Limited and may not be copied or communicated to a third party or used for any purpose other than that for which it is supplied without the express written authority of Rolls-Royce Motors Limited.”

“Whilst the information in this document given in good faith based upon the latest knowledge available to Rolls-Royce Motors Limited. Rolls-Royce Motors Limited gives no warranty or representation concerning such information, and such information must not be taken as establishing any contractual or other commitment on the part of Rolls-Royce Motors Limited.”

GENERATOR

AMMETER SWITCHBOX PARK SWITCH

GEARRANGE SELECTOR

PETROL FILLER DOOR INTERIOR LAMPS CIGAR LIGHTERS

HEIGHT CONTROL CLOCK CHARGING SOCKET

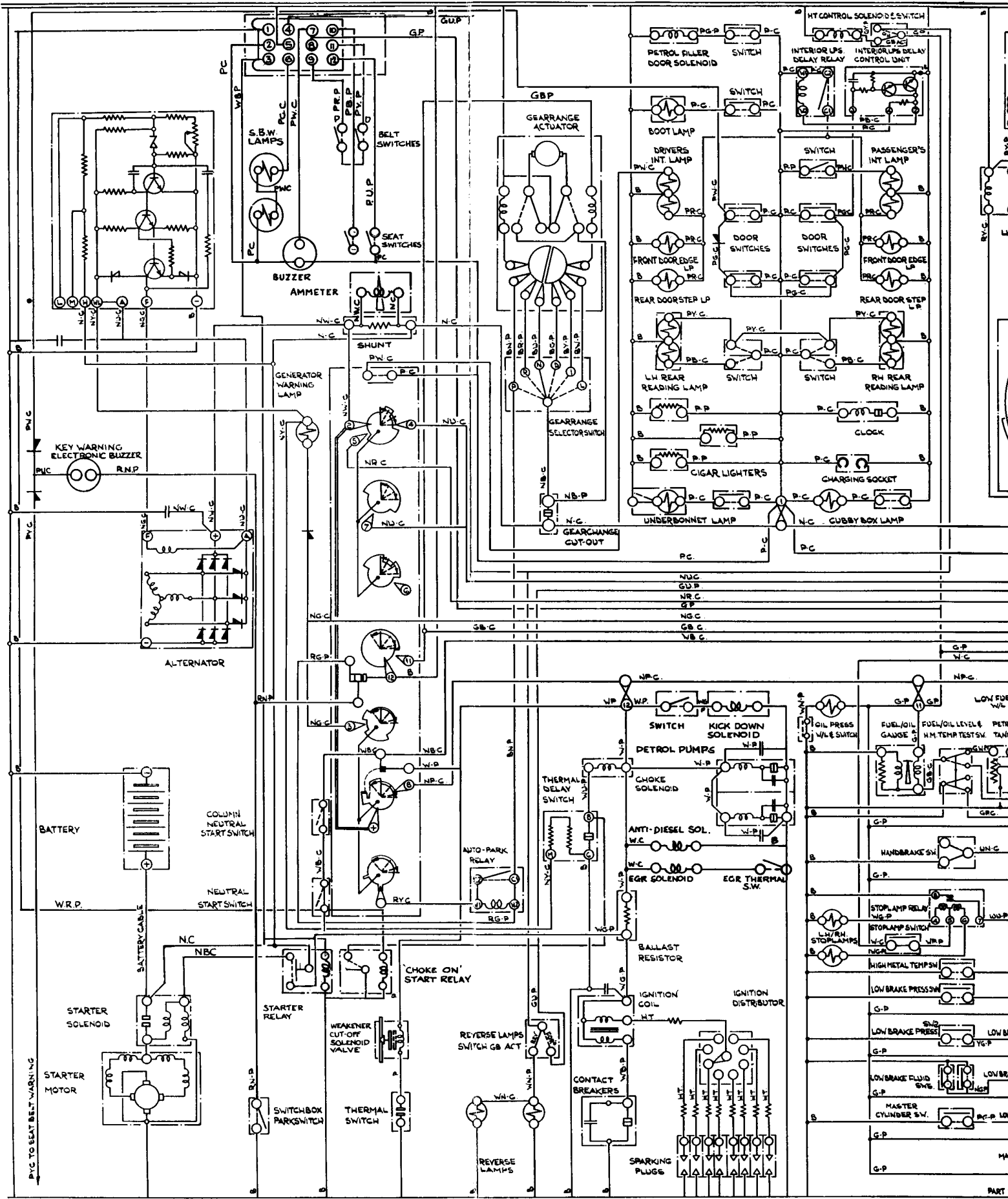

BATTERY STARTER

WEAKENER CUT-OFF VALVE REVERSE LAMPS

IGNITION

STOP LAMP HIGH MET

ELECTRICALLY OPERATED SEATS

ELECTRIC WINDOW/LIFTS WITH PM. MOTORS

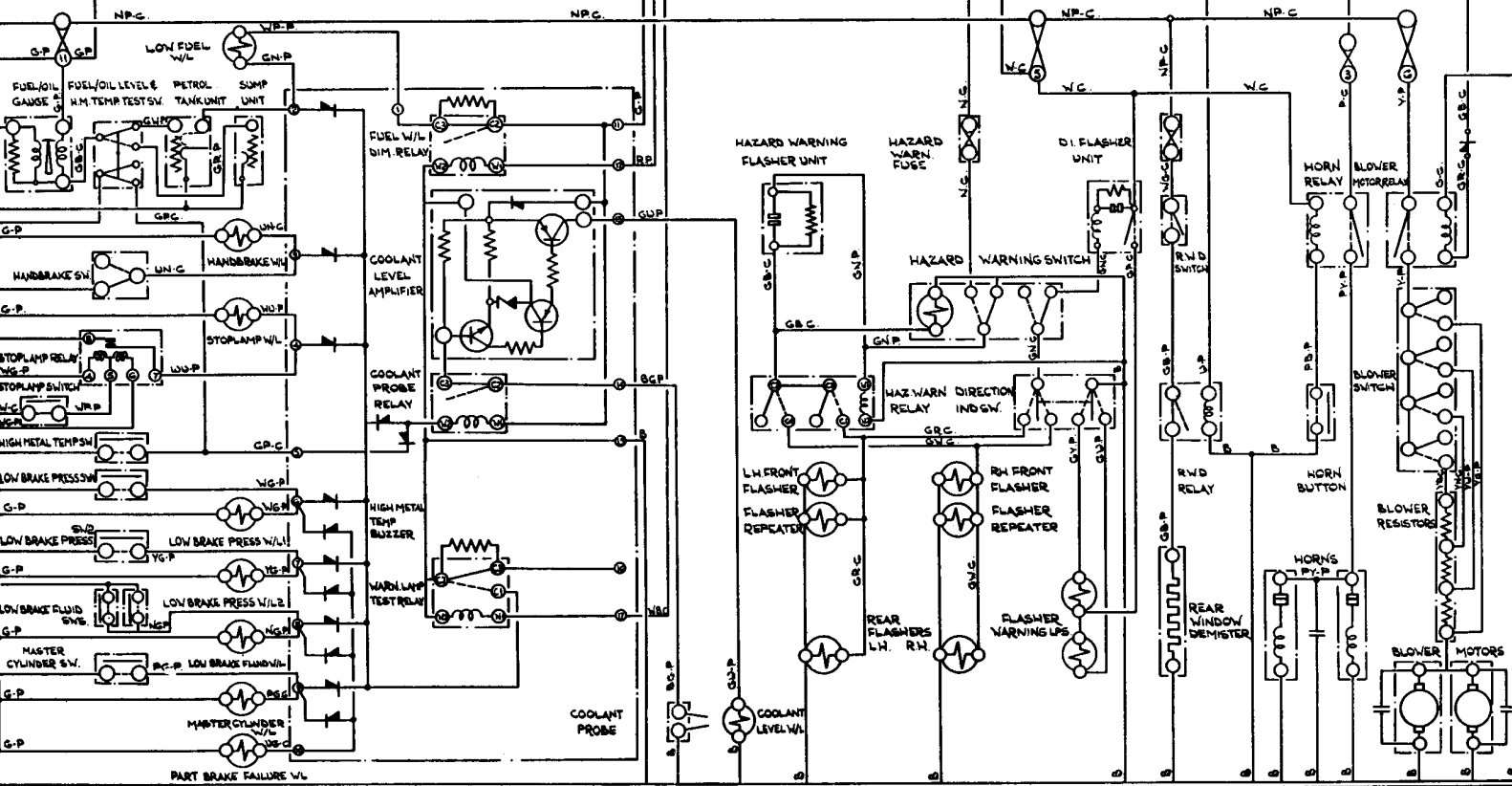
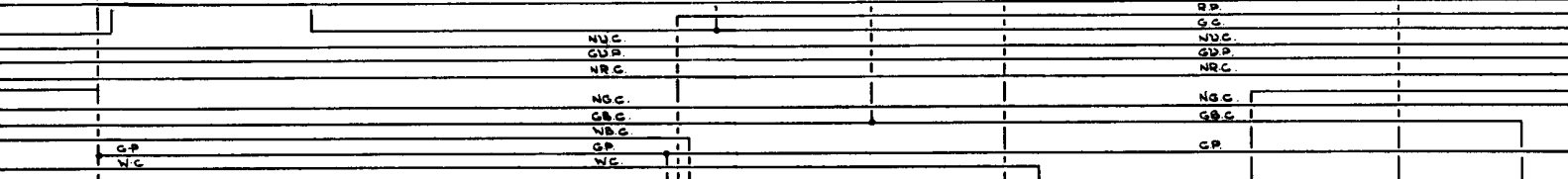
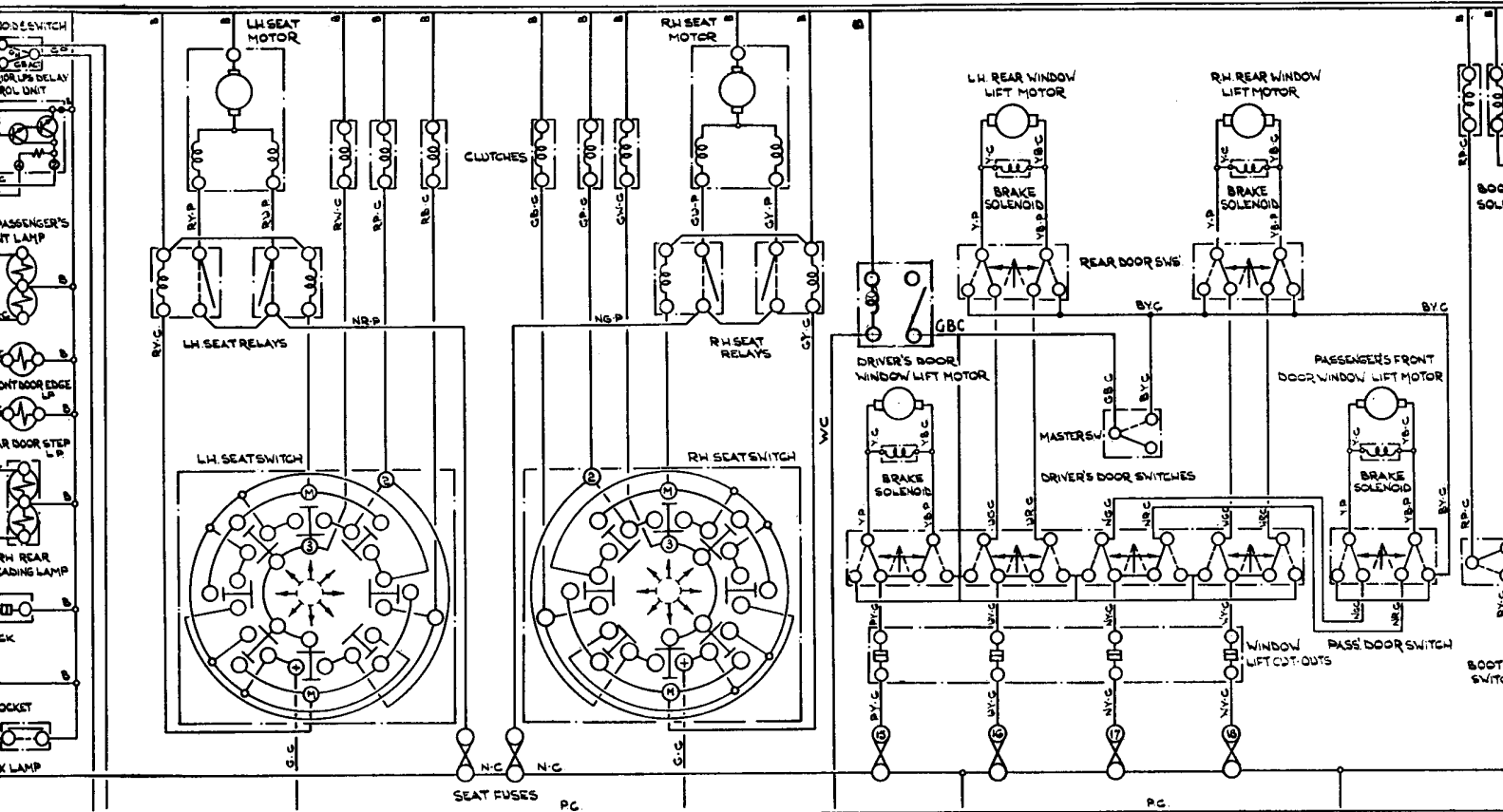

STOPLAMPS WARNING LAMPS FUEL GAUGE
HIGH METAL TEMPERATURE BUZZER COOLANT PROBE

DIRECTION INDICATORS HAZARD WARNING

REAR WINDOW
DEMISTER

HORNS

BLOWER MOTOR

CENTRALISED DOOR & BOOT LID LOCKING

HEADLAMPS

SIDELAMPS

PANEL LAMPS

AIR CONDITIONING UNIT SYSTEM

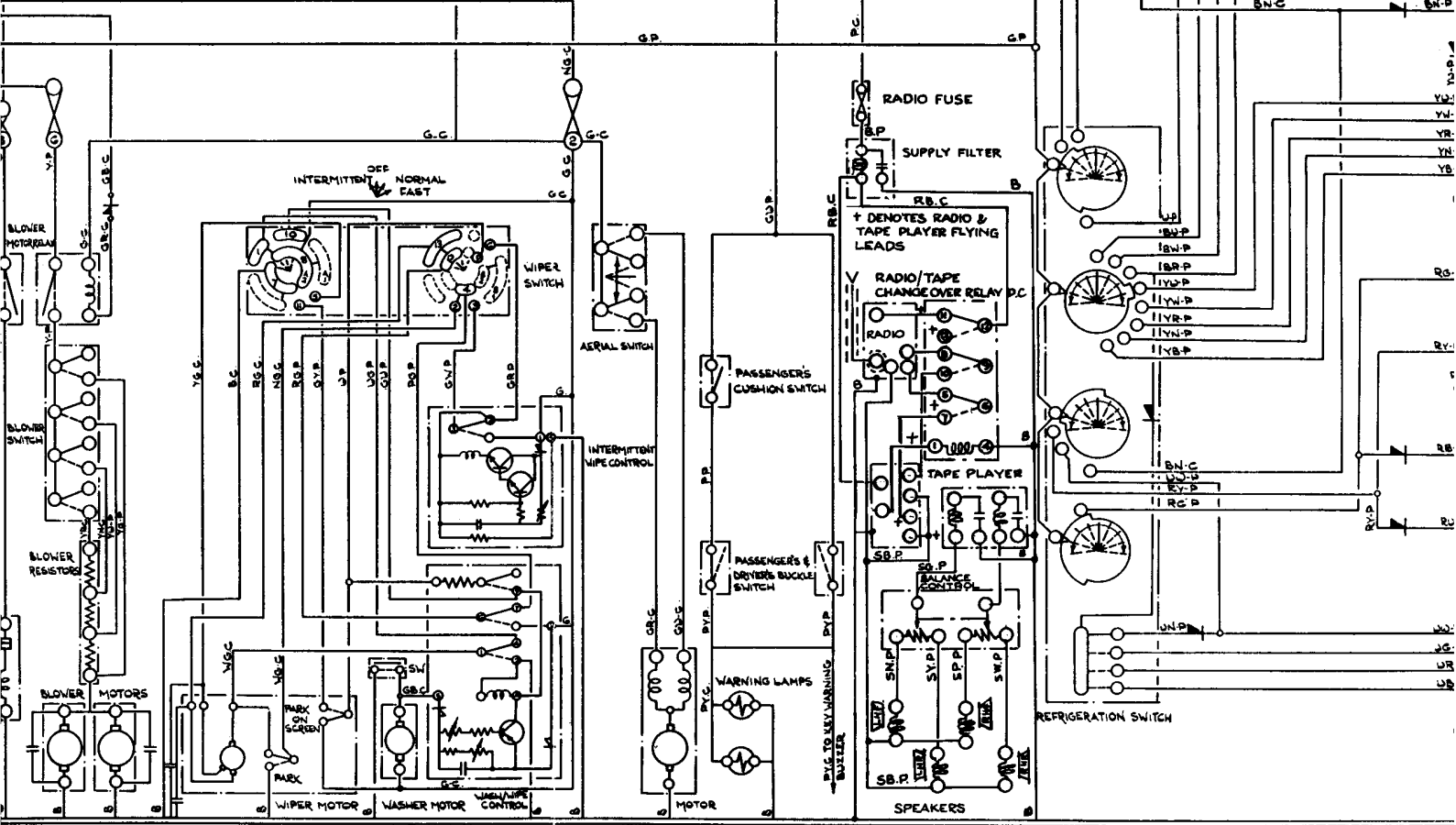
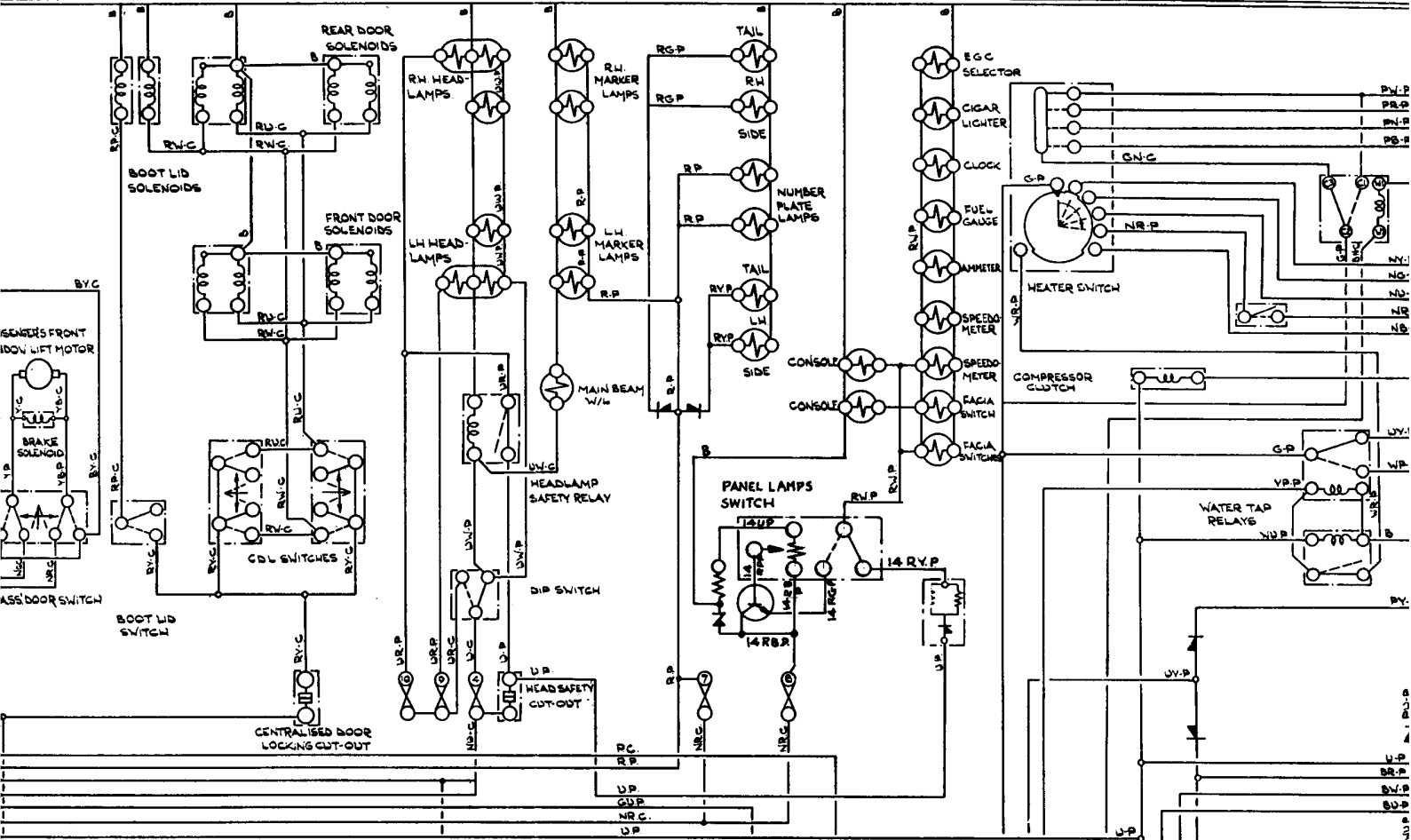

BLOWER MOTORS

WINDSCREEN WIPER (INCLUDING INTERMITTENT OPERATION) AND WASHER

AERIAL

SEAT BELT WARNING

STEREO RADIO

+ DENOTES RADIO FLYING LEAD

USED DOOR & BOOT LID LOCKING

HEADLAMPS

SIDELAMPS

PANEL LAMPS

AIR CONDITIONING UNIT SYSTEM

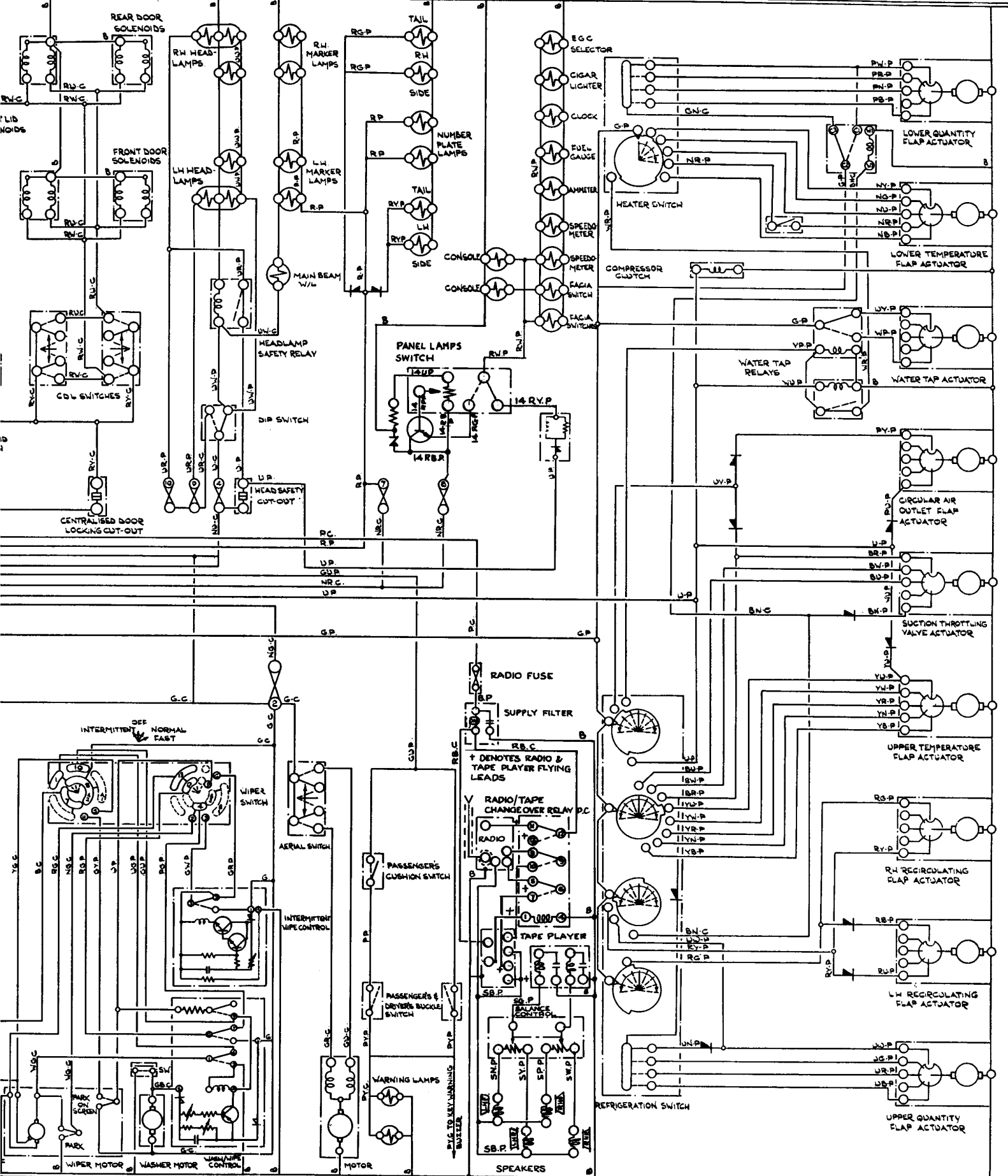

WINDSCREEN WIPER (INCLUDING INTERMITTENT OPERATION) AND WASHER

AERIAL

SEAT BELT WARNING

STEREO RADIO

† DENOTES RADIO FLYING LEAD

THEORETICAL WIRING DIAGRAM

Sheet 11

For
Rolls-Royce Silver Shadow
and
Bentley T Series

**RIGHT-HAND DRIVE LONG WHEELBASE
DIVISION CARS FROM CAR SERIAL
NUMBER 16214**

T.S.D. Publication 4029

“© Rolls-Royce Motors Limited 1974”

“This document is the property of Rolls-Royce Motors Limited and may not be copied or communicated to a third party or used for any purpose other than that for which it is supplied without the express written authority of Rolls-Royce Motors Limited.”

“Whilst the information in this document given in good faith based upon the latest knowledge available to Rolls-Royce Motors Limited. Rolls-Royce Motors Limited gives no warranty or representation concerning such information, and such information must not be taken as establishing any contractual or other commitment on the part of Rolls-Royce Motors Limited.”

IGNITION CONTROL
LOCK
CHARGING SOCKET

ELECTRICALLY OPERATED SEATS

DIVISION LIFT

ELECTRIC WINDOW LIFTS WITH PM MOTORS

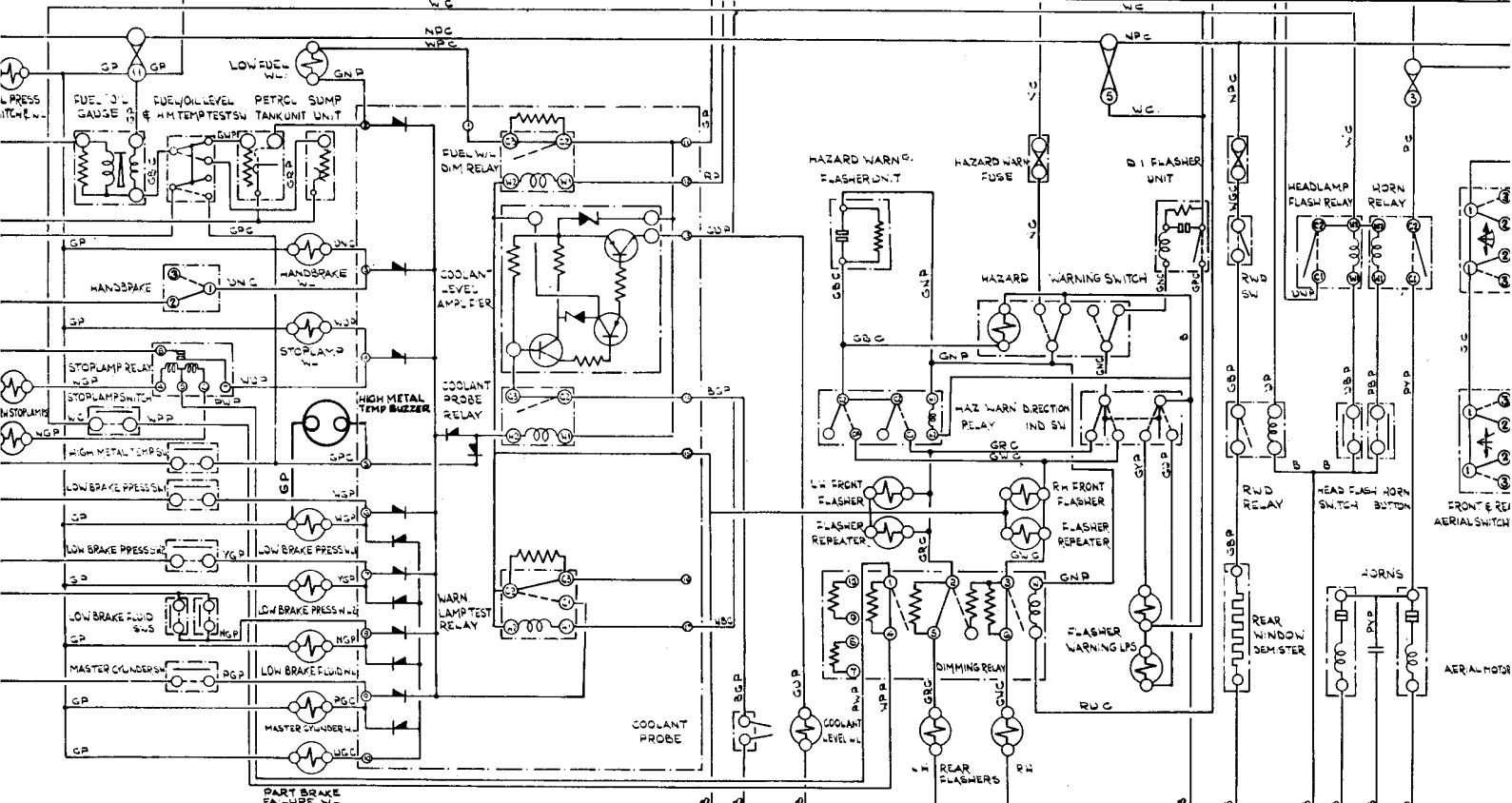
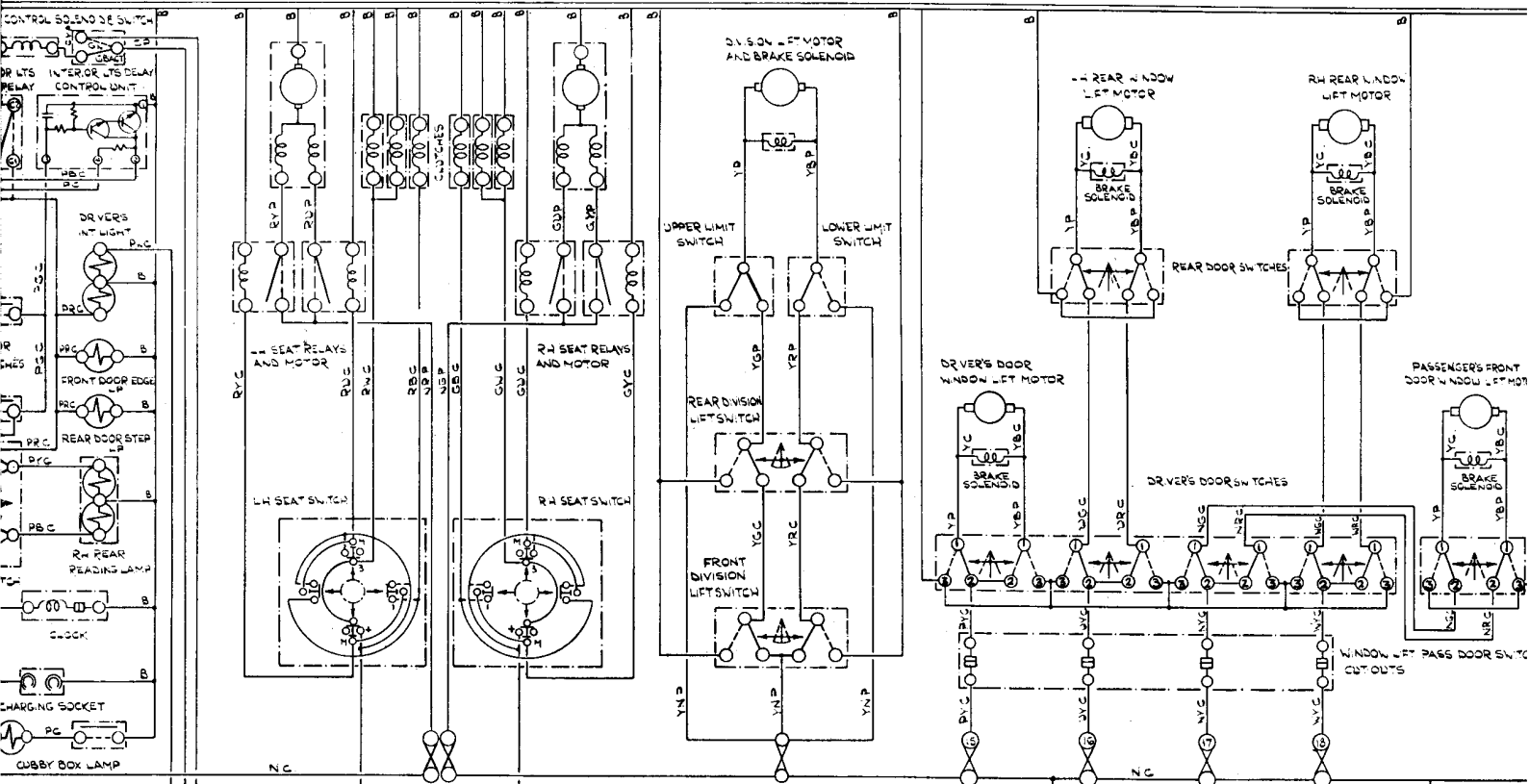

STOPLAMPS, WARNING LAMPS FUEL OIL GAUGE, HIGH METAL TEMPERATURE BUZZER COOLANT PROBE

DIRECTION INDICATORS HAZARD WARNING

REAR WINDOW DEMISTER HORNS

AERIALS

CENTRALISED DOOR AND BOOT LID LOCKING

HEADLAMPS

SIDELAMPS

PANEL LAMPS

AIRCONDITIONING UNIT FRONT BLOWER MOTORS

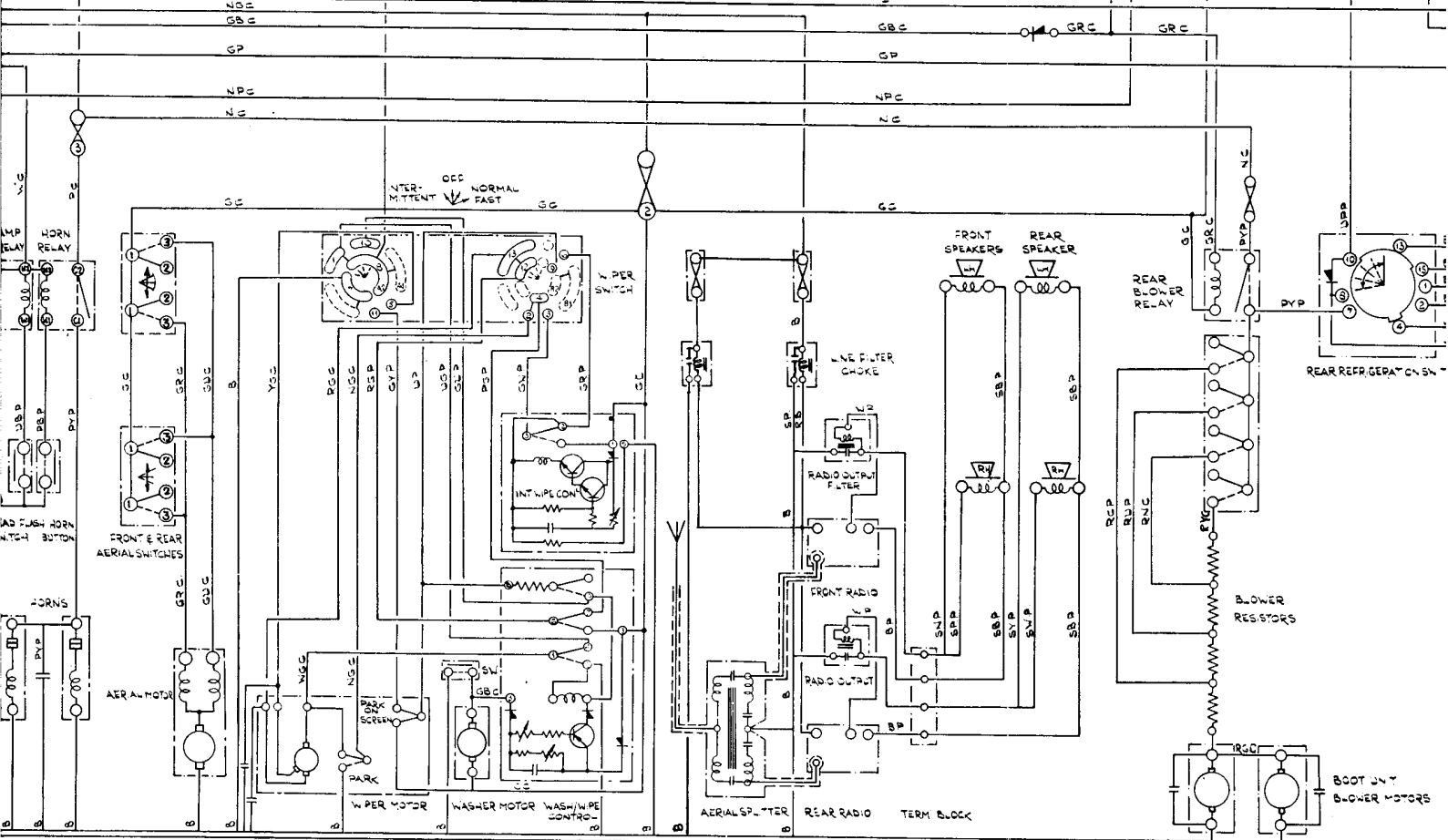
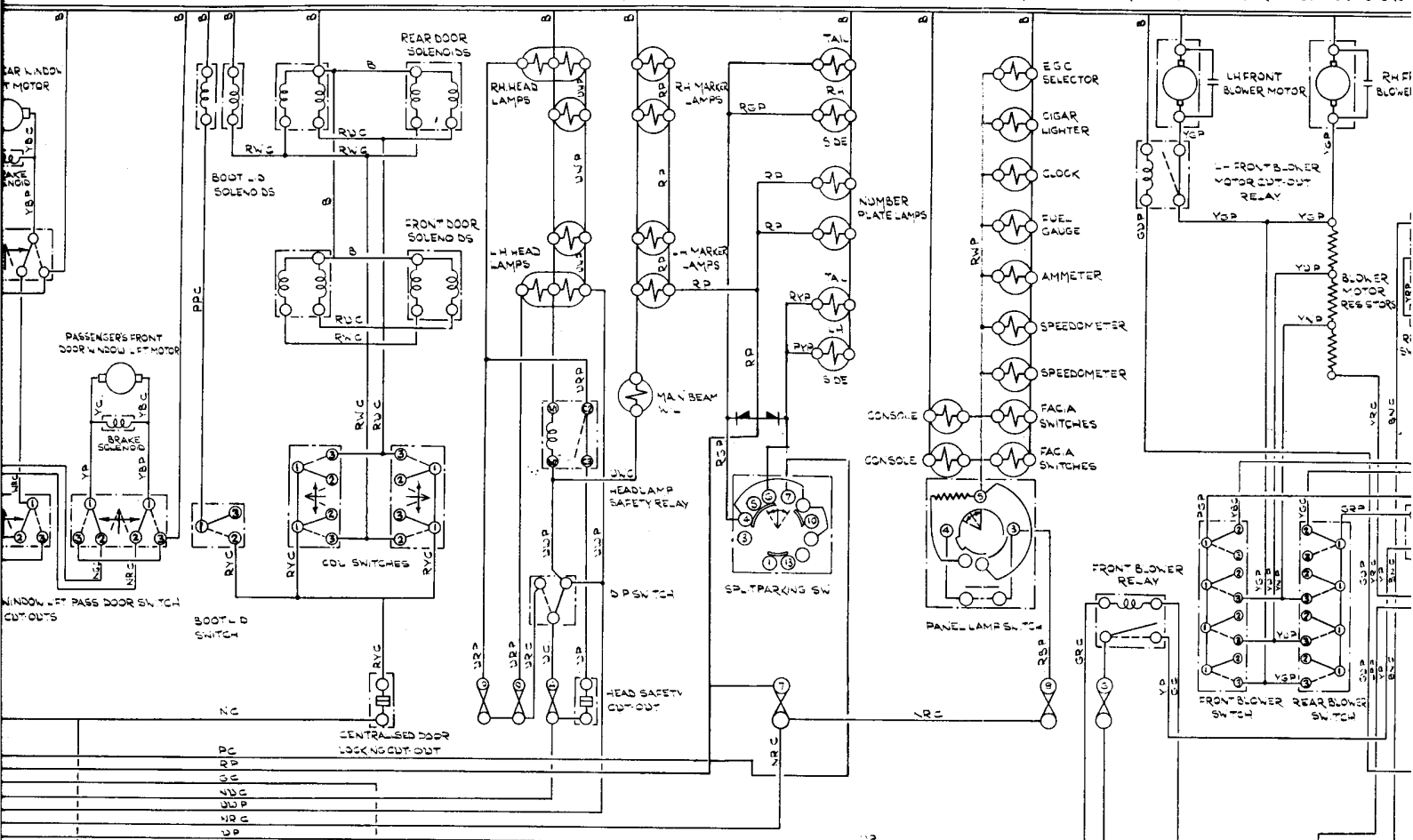

Section 16

Rolls-Royce Silver Shadow
and Bentley 'T' Series
Saloons built to August 1975
Electrical Specification
(Sheets 1 - 10)

Printed in England

December 1976

T.S.D. 2476

THEORETICAL WIRING DIAGRAM

Sheet 1

For
Rolls-Royce Silver Shadow
and
Bentley T Series

RIGHT-HAND DRIVE SALOON AND LONG WHEELBASE NON-DIVISION CARS FROM CAR SERIAL NUMBERS 22118 AND 22073

T.S.D. Publication 4150

© Rolls-Royce Motors Limited 1975

"This document is the property of Rolls-Royce Motors Limited and may not be copied or communicated to a third party or used for any purpose other than that for which it is supplied without the express written authority of Rolls-Royce Motors Limited."

"Whilst the information in this document given in good faith based upon the latest knowledge available to Rolls-Royce Motors Limited. Rolls-Royce Motors Limited gives no warranty or representation concerning such information, and such information must not be taken as establishing any contractual or other commitment on the part of Rolls-Royce Motors Limited."

ELECTRICALLY OPERATED SEATS

ELECTRIC WINDOW LIFTS WITH P.M. MOTORS

CENTRALISED DOOR

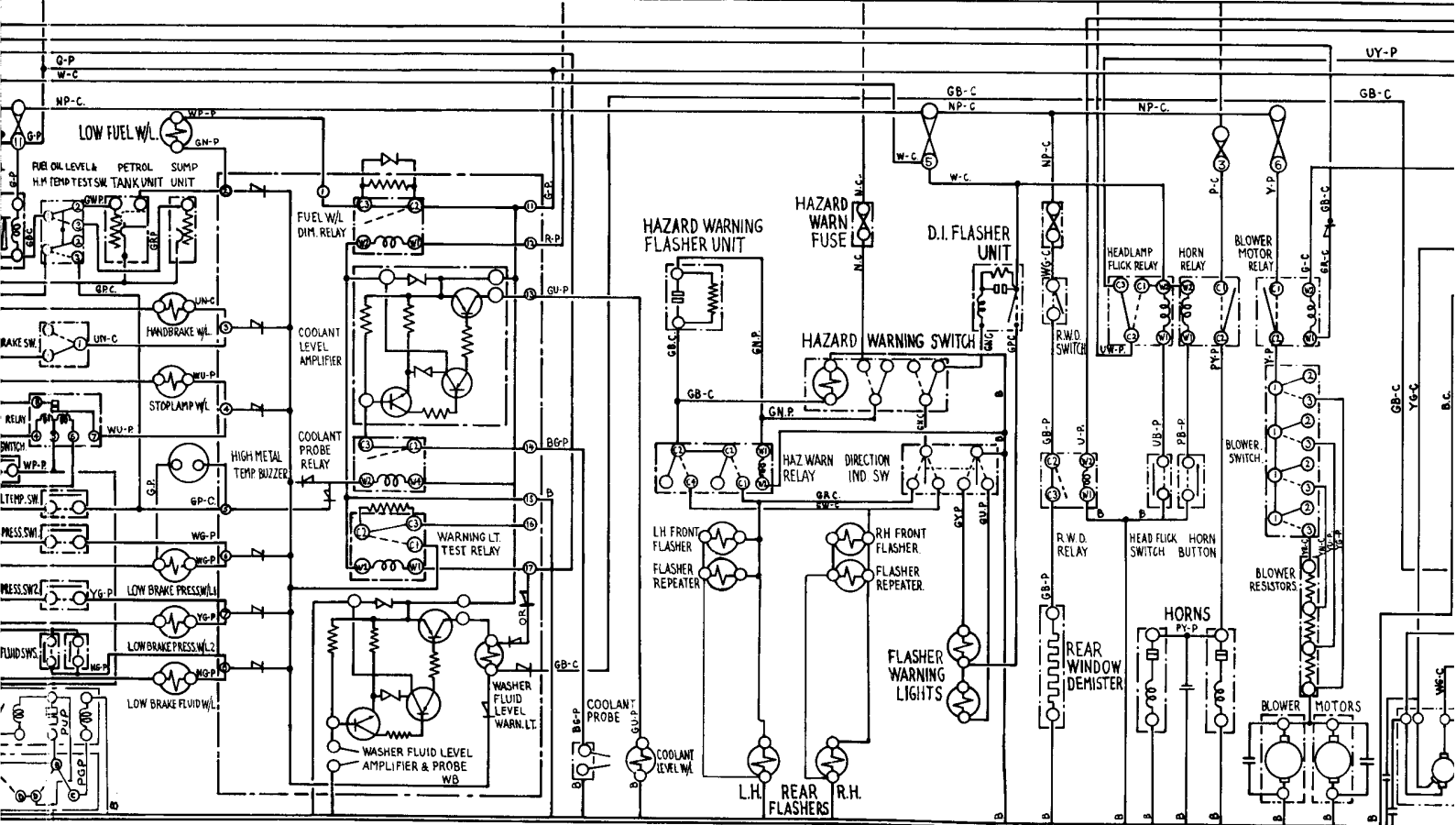
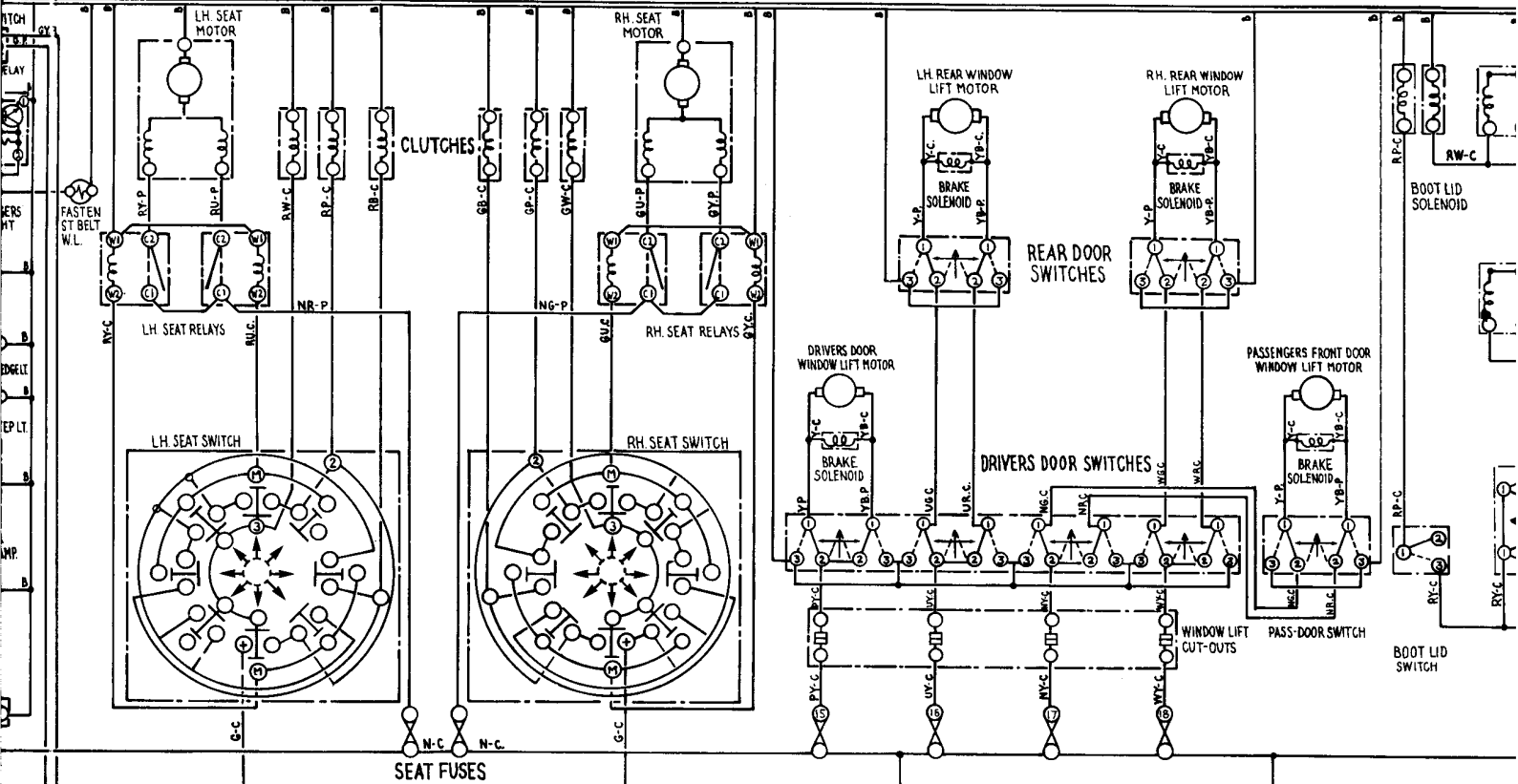

STOP LAMPS, WARNING LIGHTS, FUEL GAUGE, HIGH METAL TEMPERATURE BUZZER, COOLANT PROBE

DIRECTION INDICATORS, HAZARD WARNING

REAR WINDOW DEMISTER

HORNS

BLOWERS

CENTRALISED DOOR & BOOT LID LOCKING

QH HEADLAMPS

SIDLAMPS

PANEL LIGHTS

AIR CONDITIONING SYSTEM

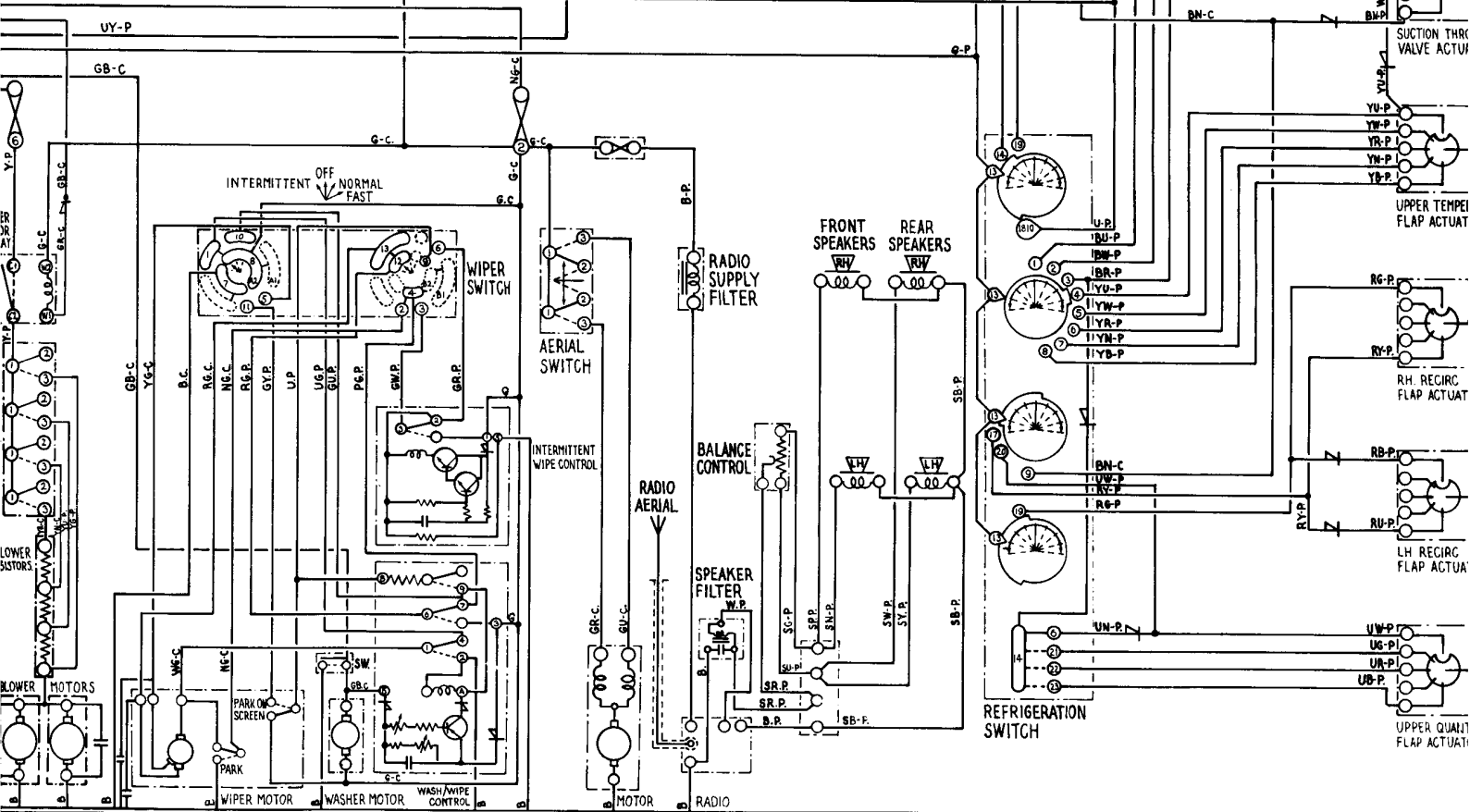
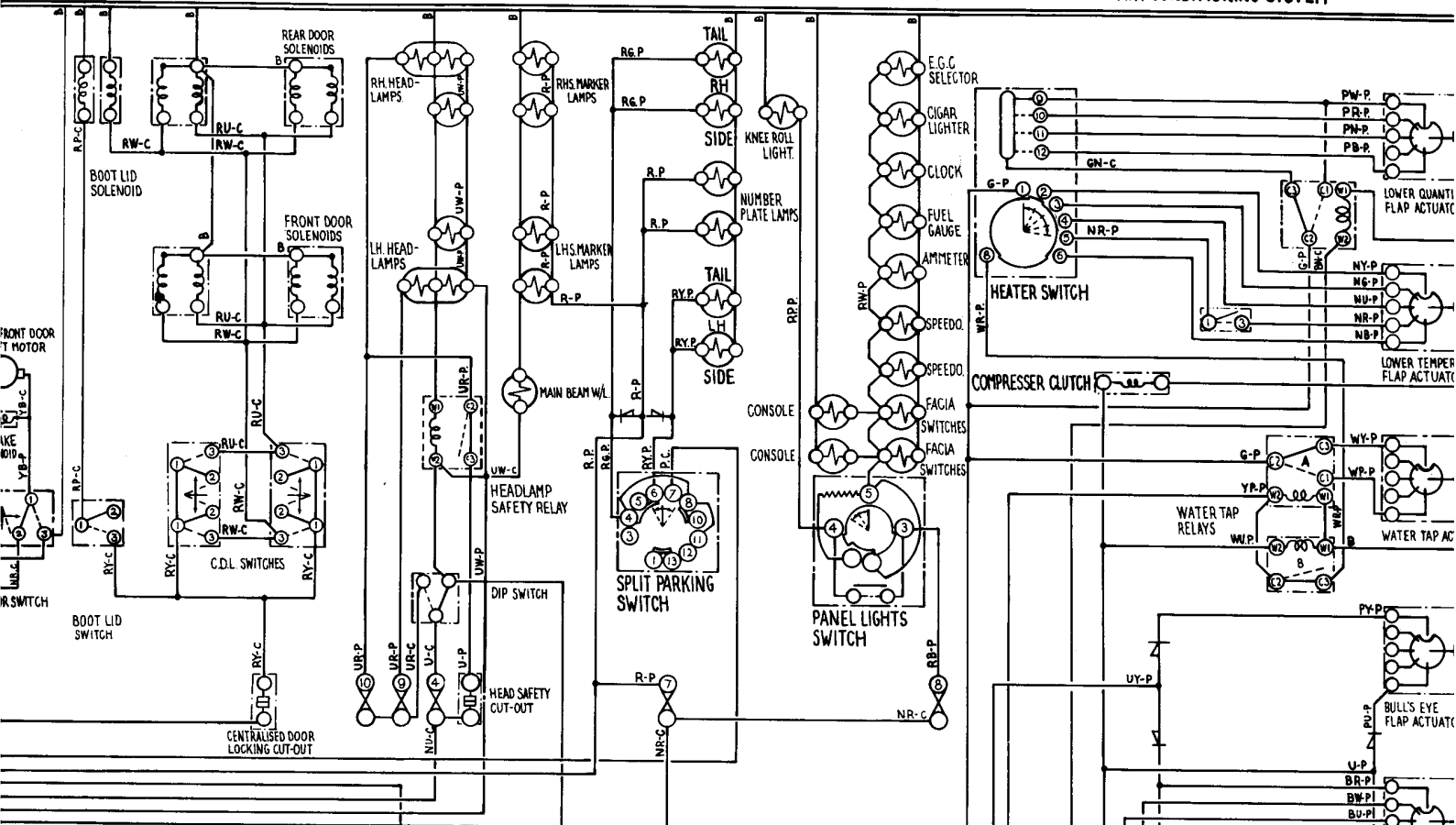

BLOWERS. WINDSCREEN WIPER AND WASHER AERIAL RADIO

REAR DOOR & BOOT LID LOCKING QH HEADLAMPS SIDELAMPS PANEL LIGHTS AIR CONDITIONING SYSTEM

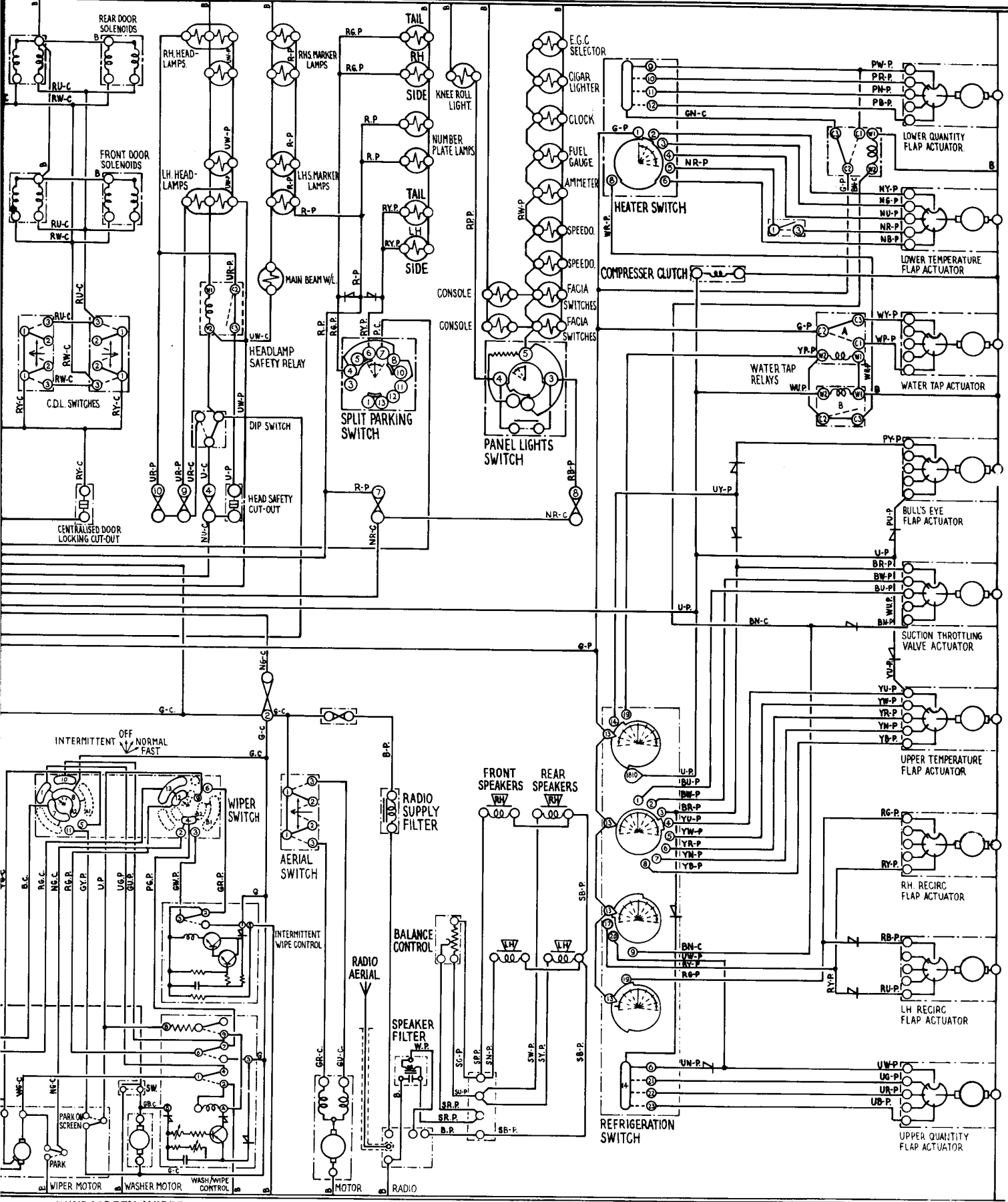

WINDSCREEN WIPER AND WASHER AERIAL RADIO REFRIGERATION SWITCH

THEORETICAL WIRING DIAGRAM

Sheet 2

For
Rolls-Royce Silver Shadow
and
Bentley T Series

**LEFT-HAND DRIVE SALOON AND LONG
WHEELBASE NON-DIVISION CARS FOR
COUNTRIES OTHER THAN USA AND
CANADA FROM CAR SERIAL NUMBERS
22118 AND 22073**

T.S.D. Publication 4149

© Rolls-Royce Motors Limited 1975

"This document is the property of Rolls-Royce Motors Limited and may not be copied or communicated to a third party or used for any purpose other than that for which it is supplied without the express written authority of Rolls-Royce Motors Limited."

"Whilst the information in this document given in good faith based upon the latest knowledge available to Rolls-Royce Motors Limited. Rolls-Royce Motors Limited gives no warranty or representation concerning such information, and such information must not be taken as establishing any contractual or other commitment on the part of Rolls-Royce Motors Limited."

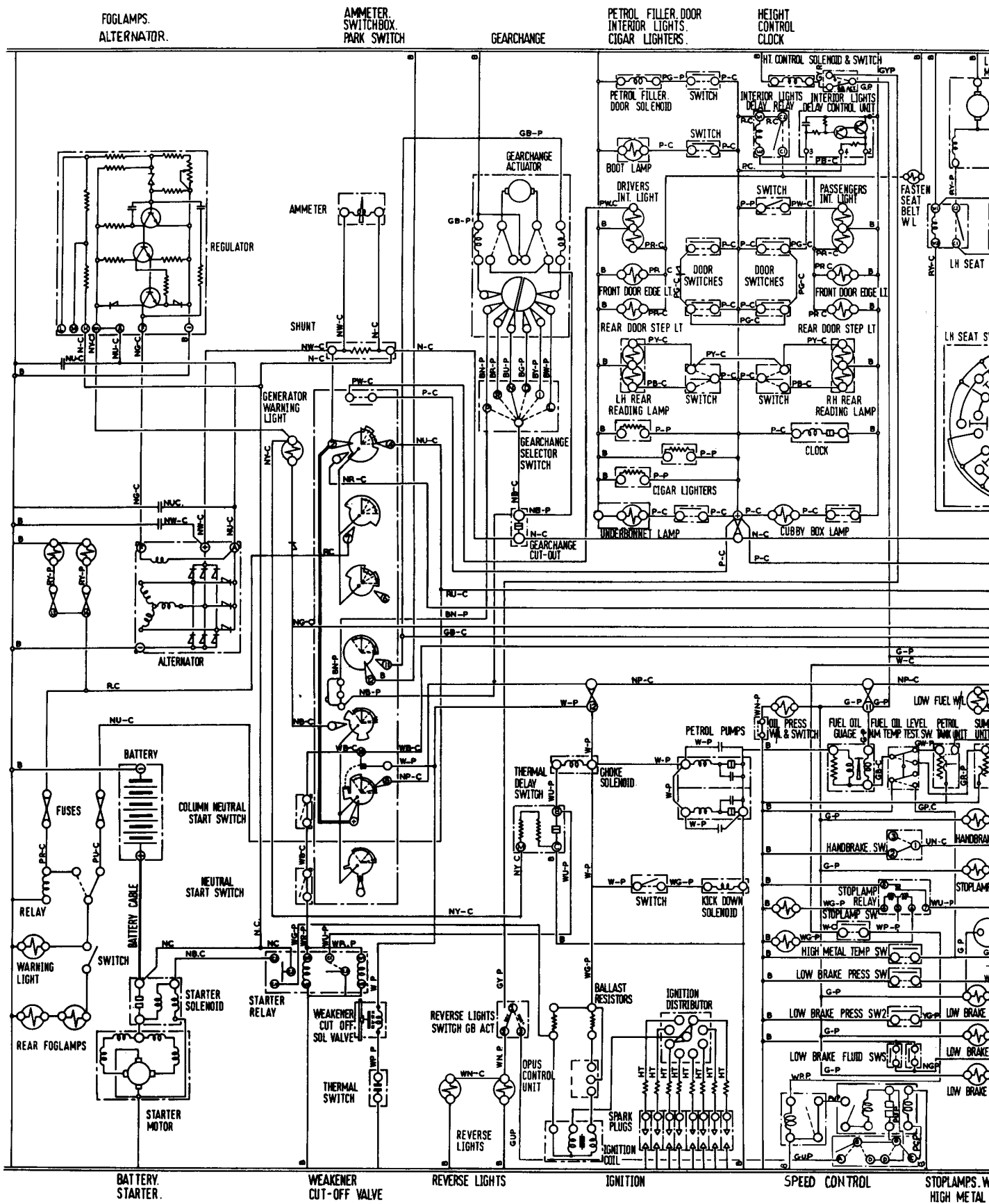

FOGLAMPS.
ALTERNATOR.

AMMETER.
SWITCHBOX.
PARK SWITCH

GEARCHANGE

PETROL FILLER. DOOR.
INTERIOR LIGHTS.
CIGAR LIGHTERS.

HEIGHT CONTROL
CLOCK

BATTERY.
STARTER.

WEAKENER
CUT-OFF VALVE

REVERSE LIGHTS

IGNITION

SPEED CONTROL

STOPLAMPS. HIGH METAL

ELECTRICALLY OPERATED SEATS

ELECTRIC WINDOW LIFTS WITH PM MOTORS

CENTRALISED DOOR & BOOT LID LOCKING

O.H. HEADLAMP

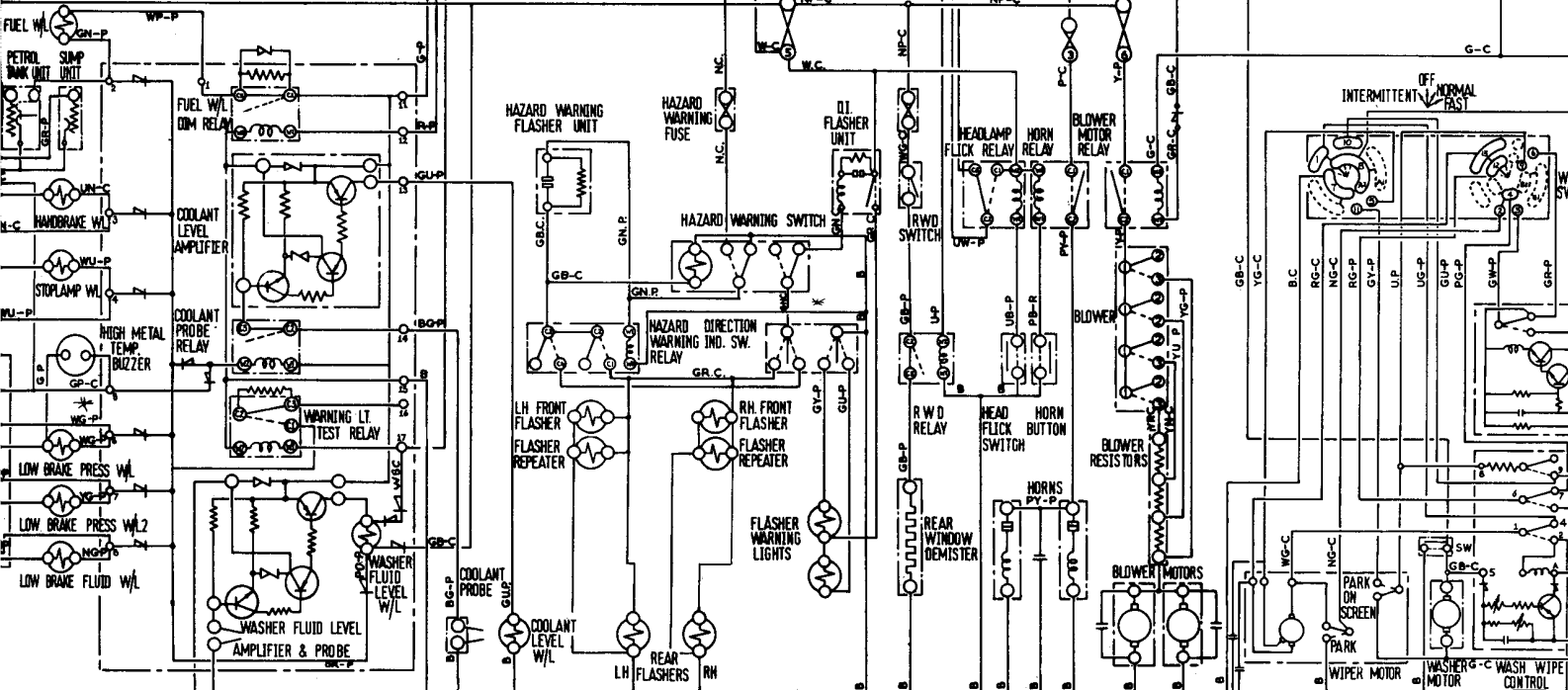
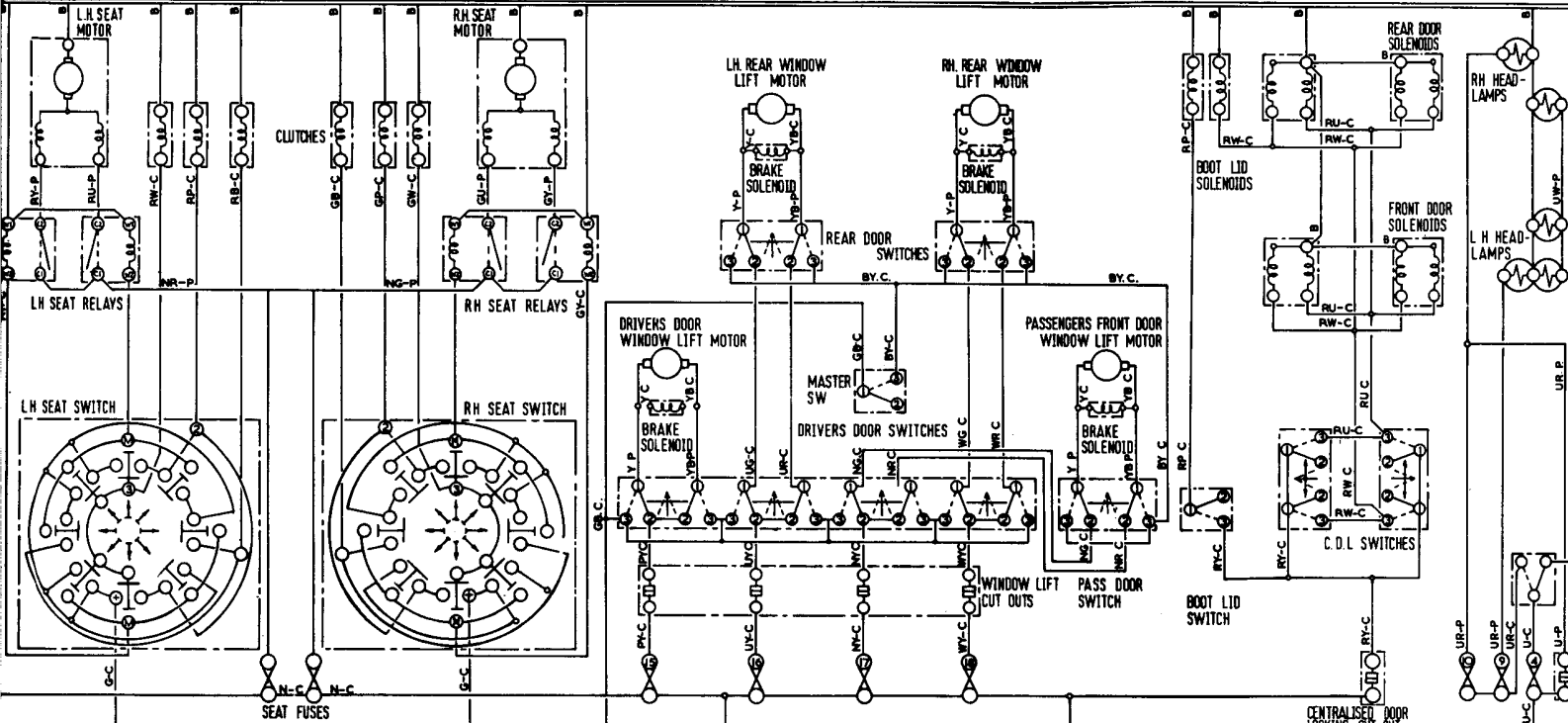

HEADLAMP, WARNING LIGHTS, FUEL GAUGE, HIGH METAL TEMPERATURE BUZZER, COOLANT PROBE.

DIRECTION INDICATORS HAZARD WARNING

REAR WINDOW DEMISTER

HORNS

BLOWERS

WINDSCREEN WIPER & WASHER

CENTRALISED DOOR & BOOT LID LOCKING

QH HEADLAMPS

SIDELAMPS

PANEL LIGHTS

AIR CONDITIONING SYSTEM

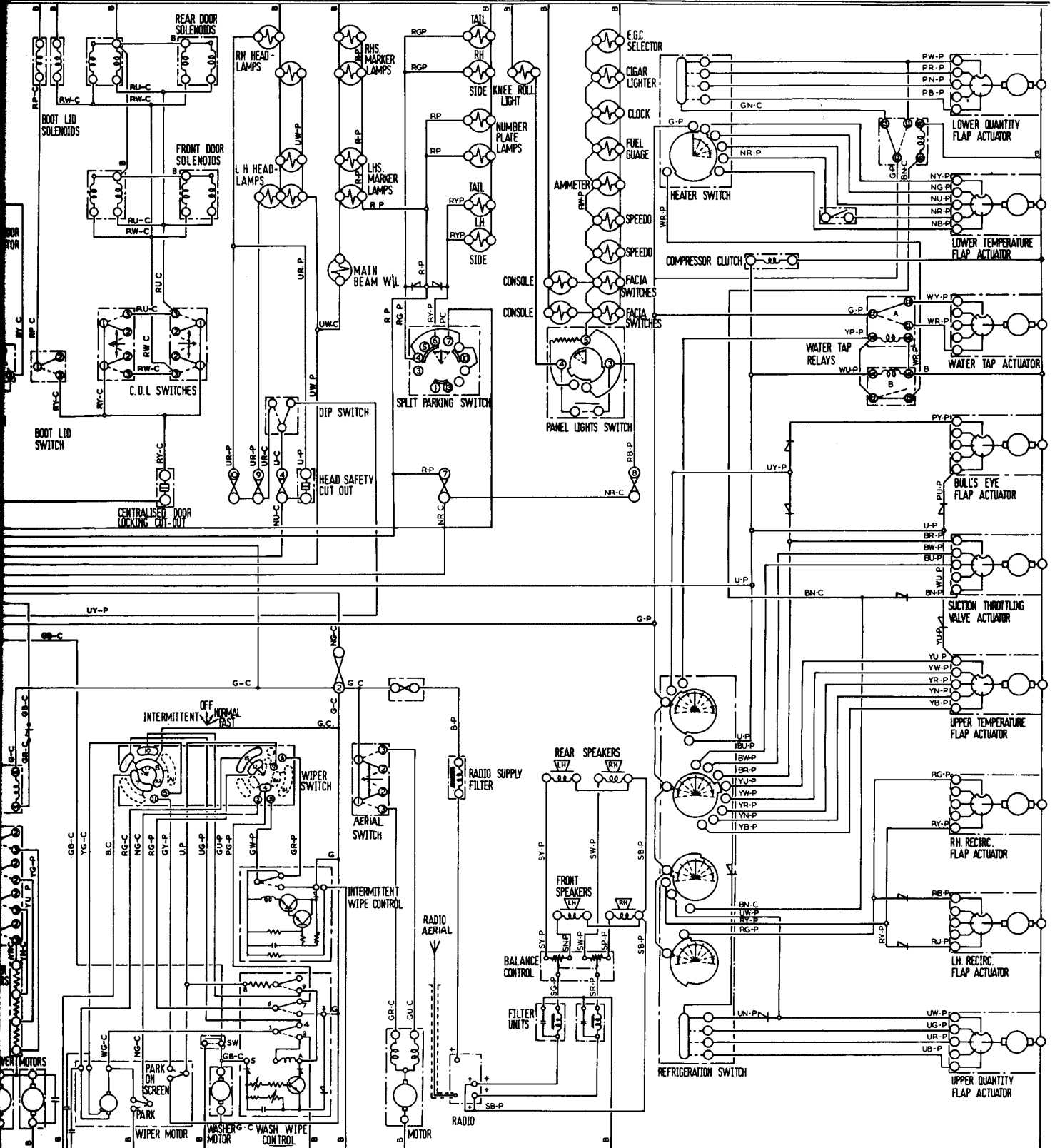

LOWERS

WINDSCREEN WIPER & WASHER

STEREO RADIO

THEORETICAL WIRING DIAGRAM

Sheet 3

For
Rolls-Royce Silver Shadow
and
Bentley T Series

SALOON AND LONG WHEELBASE NON-DIVISION CARS FOR USA AND CANADA FROM CAR SERIAL NUMBERS 22118 AND 22073

T.S.D. Publication 4148

© Rolls-Royce Motors Limited 1975

"This document is the property of Rolls-Royce Motors Limited and may not be copied or communicated to a third party or used for any purpose other than that for which it is supplied without the express written authority of Rolls-Royce Motors Limited."

"Whilst the information in this document given in good faith based upon the latest knowledge available to Rolls-Royce Motors Limited, Rolls-Royce Motors Limited gives no warranty or representation concerning such information, and such information must not be taken as establishing any contractual or other commitment on the part of Rolls-Royce Motors Limited."

ELECTRICALLY OPERATED SEATS

ELECTRIC WINDOW LIFTS WITH P.M.MOTORS

CENTRALISED DOOR & BOOT LID LOCKING

HEAD

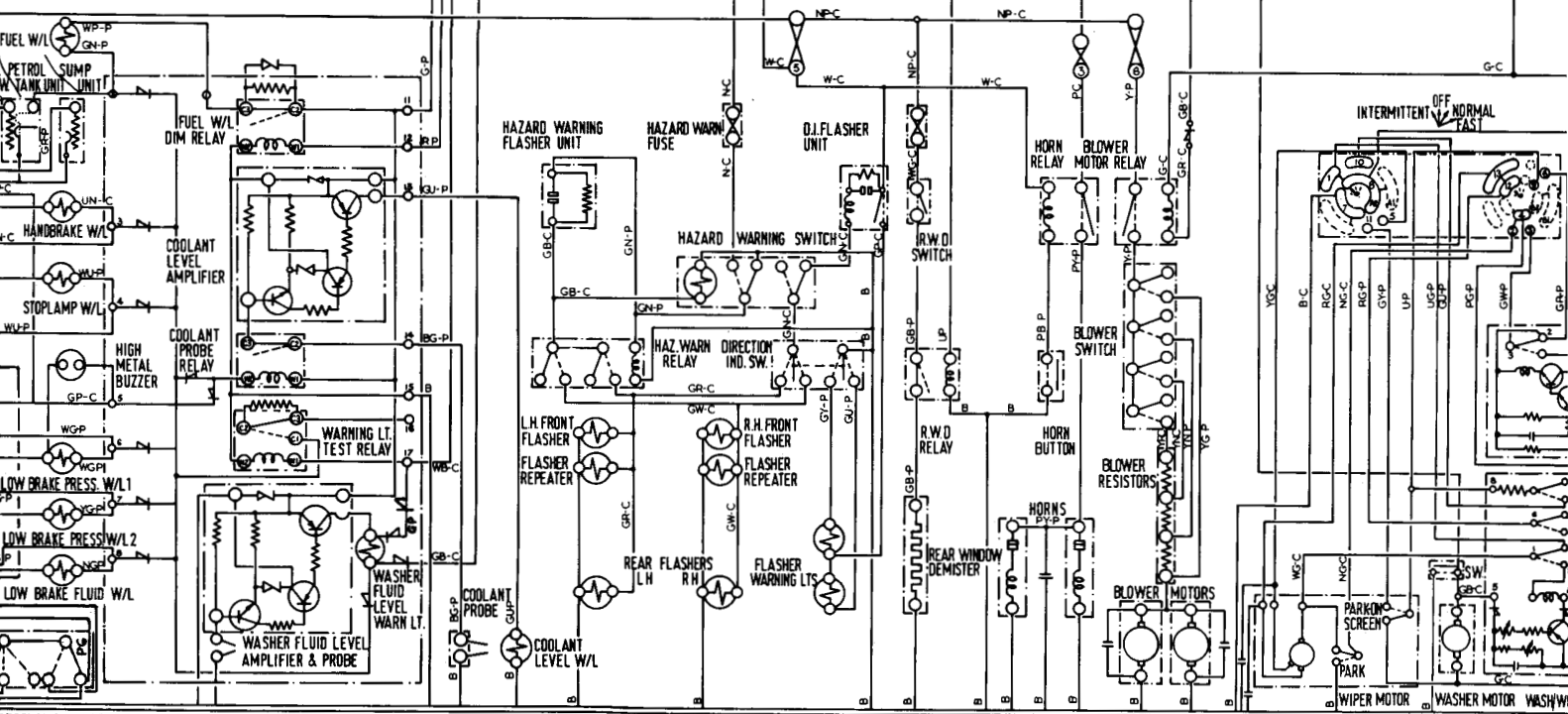
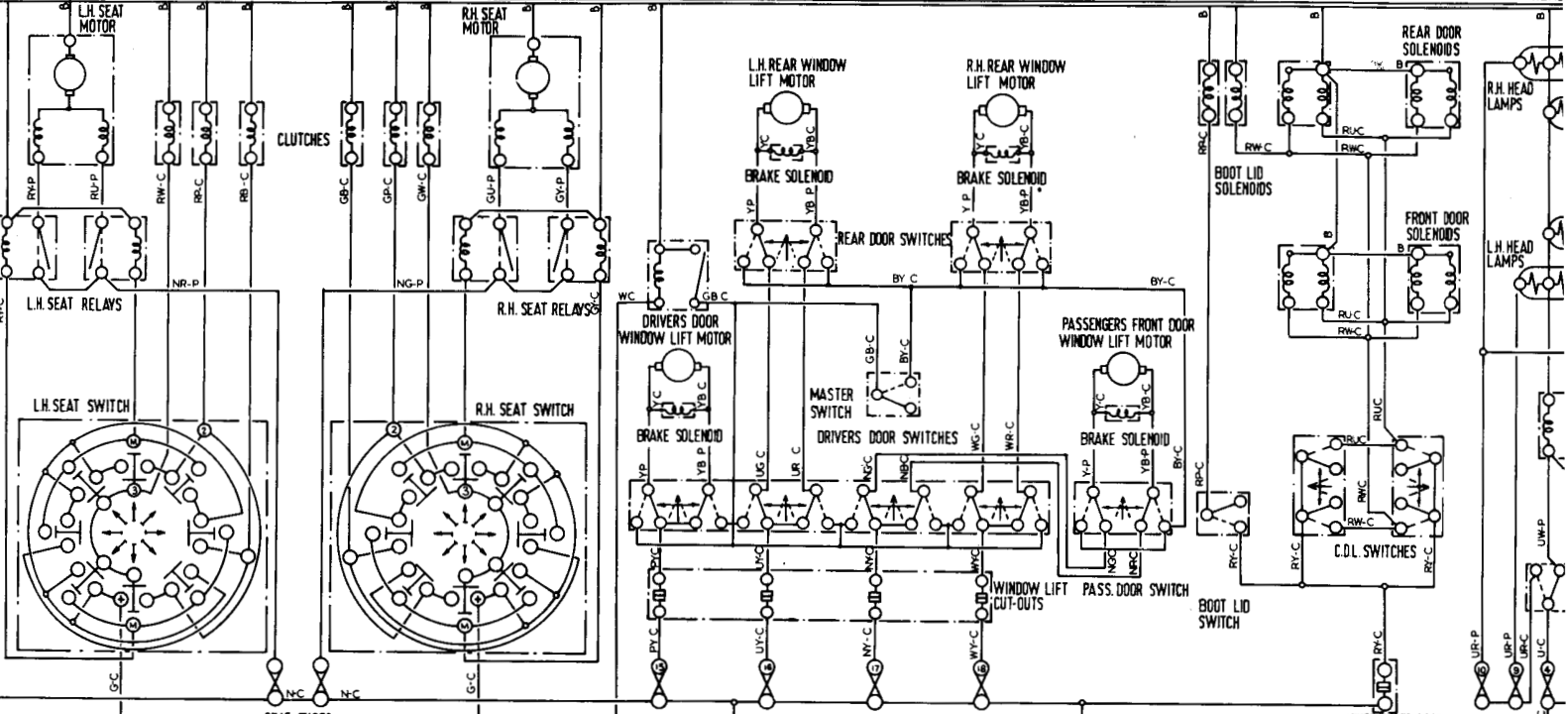

STOP LAMPS WARNING LIGHTS FUEL GAUGE HIGH METAL TEMPERATURE BUZZER COOLANT PROBE
 DIRECTION INDICATORS/HAZARD WARNING REAR WINDOW DEMISTER HORNS BLOWERS
 WINDSCREEN WIPER & WASHER

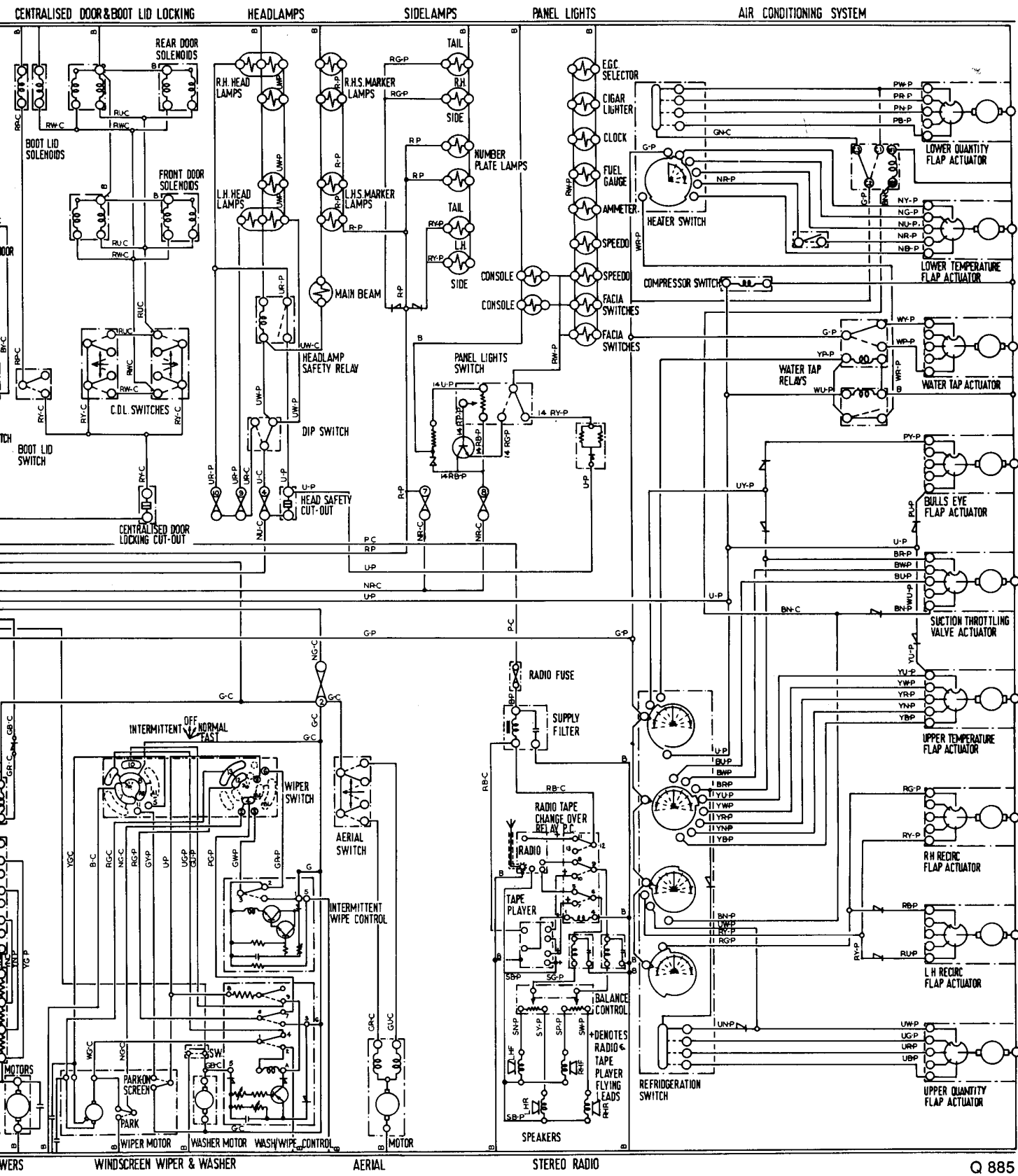

THEORETICAL WIRING DIAGRAM

Sheet 4

For
Rolls-Royce Silver Shadow
and
Bentley T Series

RIGHT-HAND DRIVE LONG WHEELBASE DIVISION CARS FROM CAR SERIAL NUMBER 22073

T.S.D. Publication 4146

© Rolls-Royce Motors Limited 1975

"This document is the property of Rolls-Royce Motors Limited and may not be copied or communicated to a third party or used for any purpose other than that for which it is supplied without the express written authority of Rolls-Royce Motors Limited."

"Whilst the information in this document given in good faith based upon the latest knowledge available to Rolls-Royce Motors Limited, Rolls-Royce Motors Limited gives no warranty or representation concerning such information, and such information must not be taken as establishing any contractual or other commitment on the part of Rolls-Royce Motors Limited."

THEORETICAL WIRING DIAGRAM

Sheet 5

For
Rolls-Royce Silver Shadow
and
Bentley T Series

LEFT-HAND DRIVE LONG WHEELBASE DIVISION CARS FOR COUNTRIES OTHER THAN USA AND CANADA FROM CAR SERIAL NUMBER 22073

T.S.D. Publication 4147

© Rolls-Royce Motors Limited 1975

"This document is the property of Rolls-Royce Motors Limited and may not be copied or communicated to a third party or used for any purpose other than that for which it is supplied without the express written authority of Rolls-Royce Motors Limited."

"Whilst the information in this document given in good faith based upon the latest knowledge available to Rolls-Royce Motors Limited. Rolls-Royce Motors Limited gives no warranty or representation concerning such information, and such information must not be taken as establishing any contractual or other commitment on the part of Rolls-Royce Motors Limited."

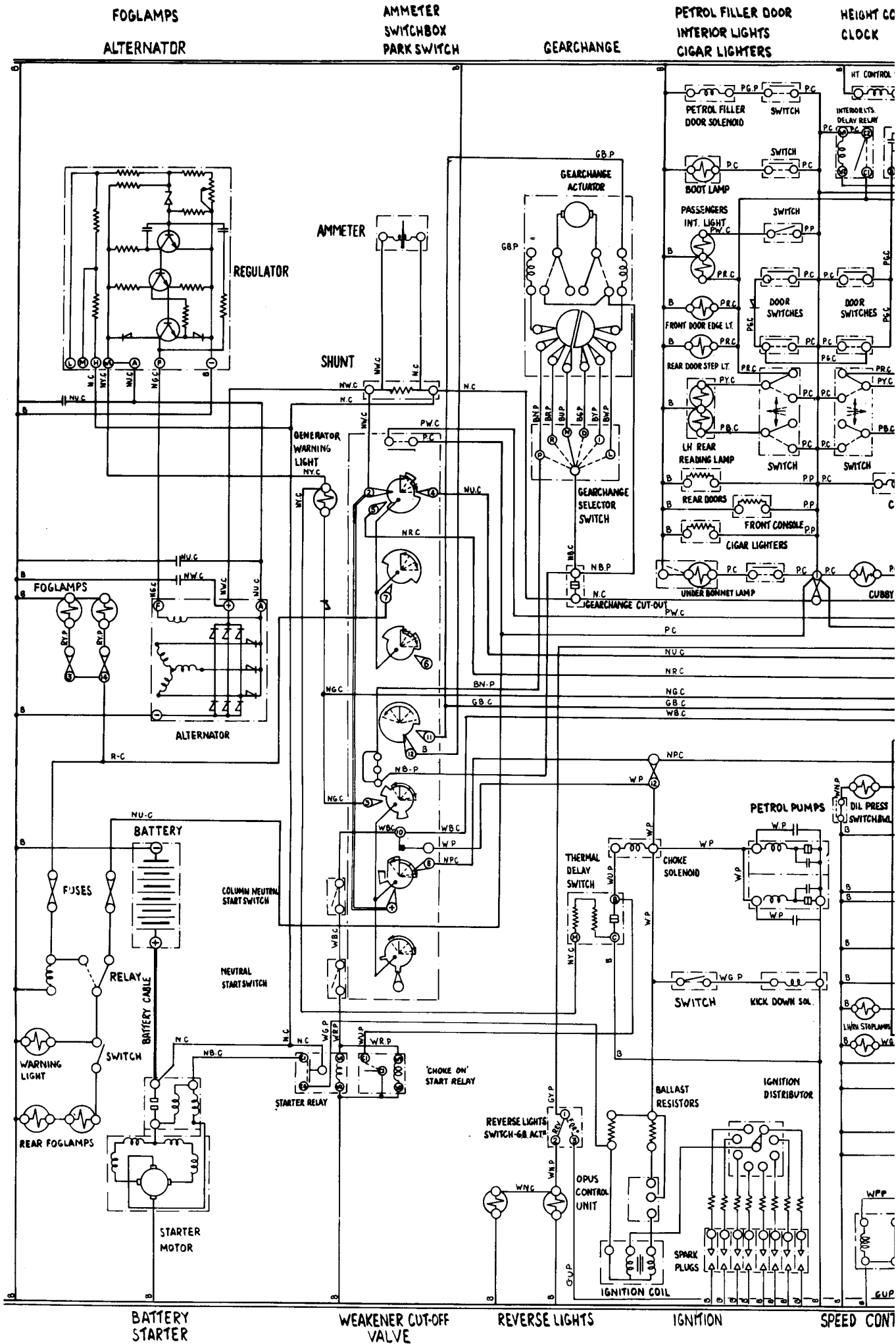

HEIGHT CONTROL
CLOCK

ELECTRICALLY OPERATED SEATS

DIVISION LIFT

ELECTRIC WINDOW LIFTS WITH P.M. MOTOR

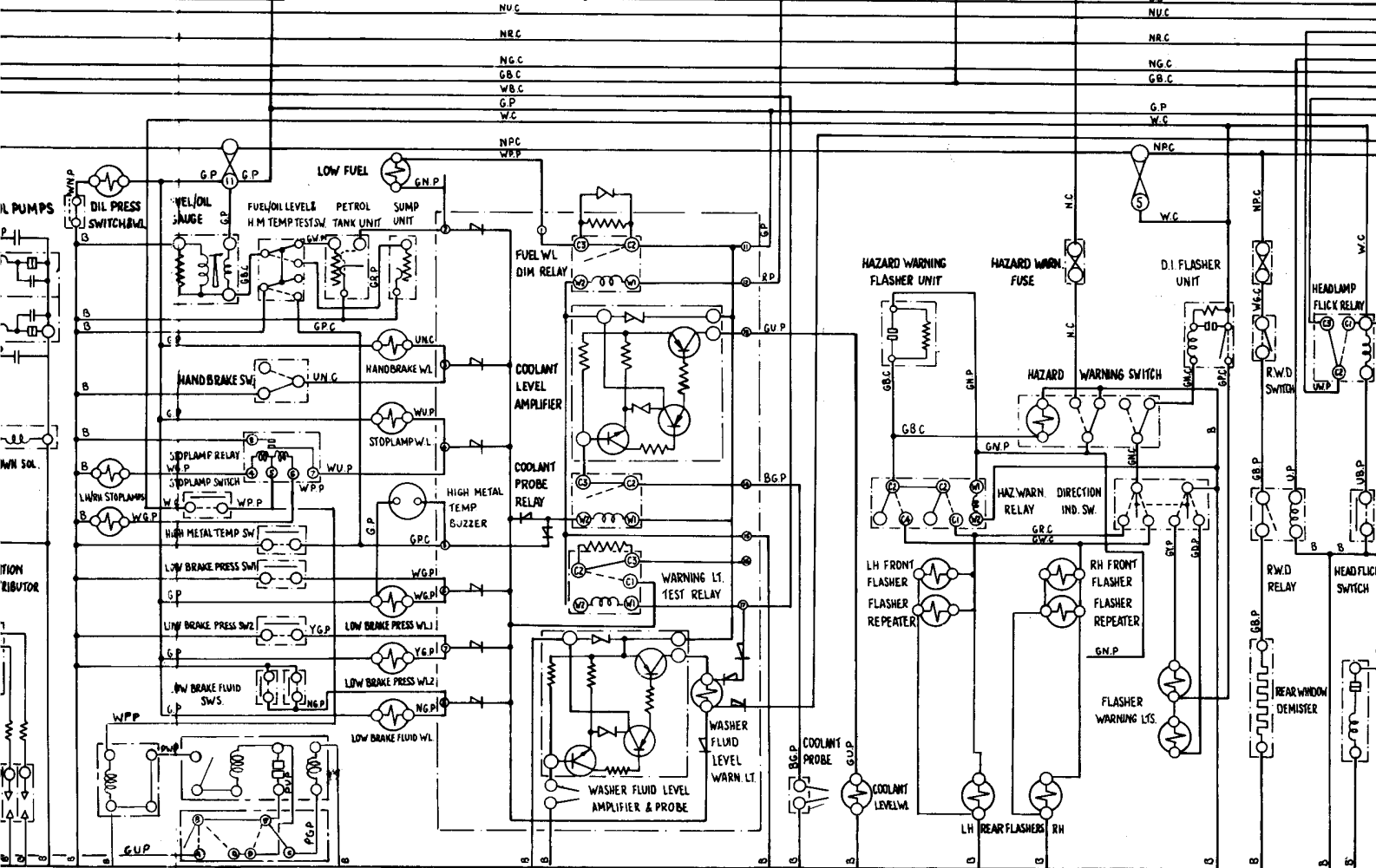
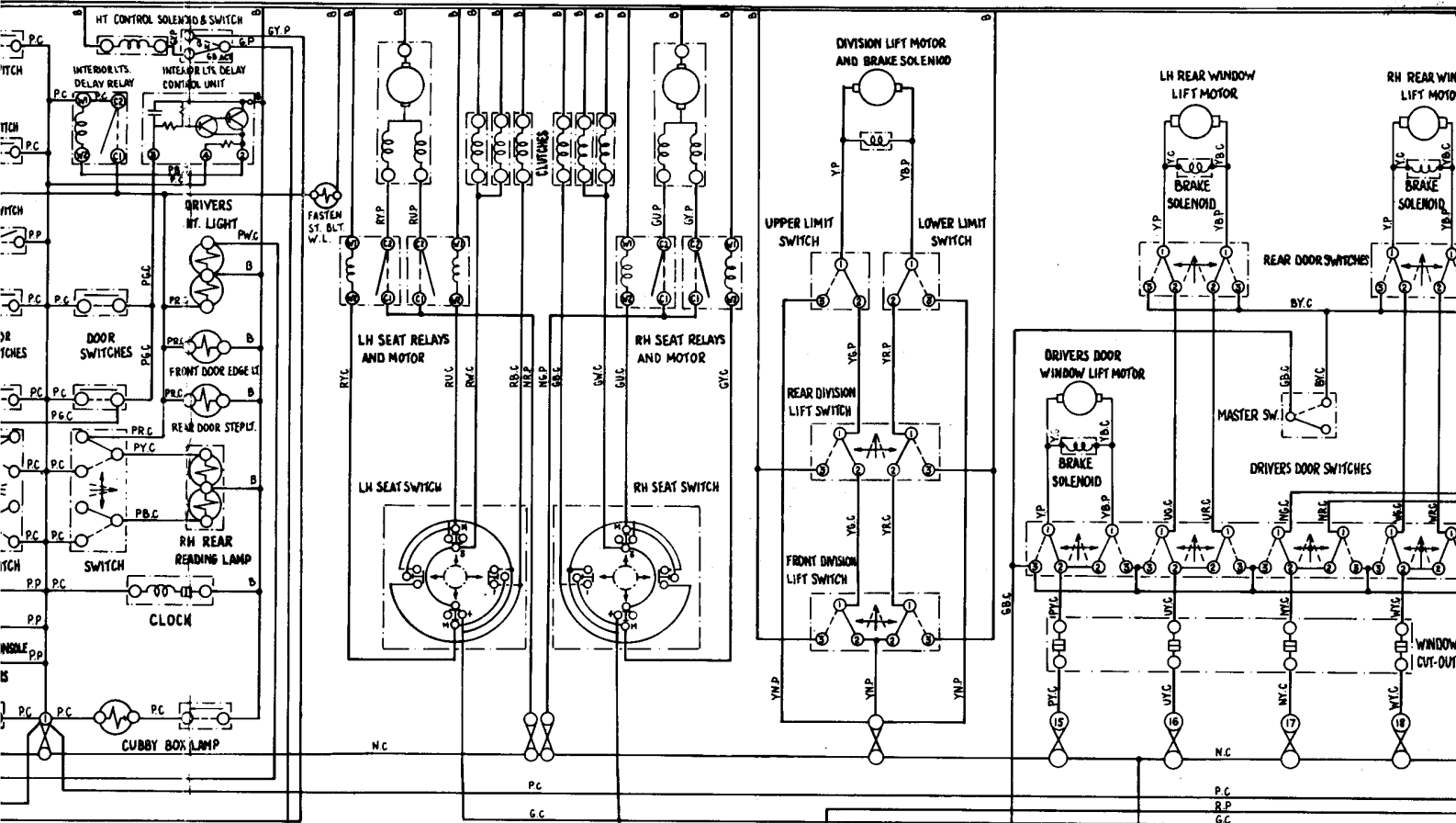

SPEED CONTROL

STOPLAMPS, WARNING LIGHTS, FUEL/OIL GAUGE,
HIGH METAL TEMPERATURE BUZZER, COOLANT PROBE

DIRECTION INDICATORS, HAZARD WARNING

REAR WINDOW
DEMISTER

PANEL LIGHTS

ACU FRONT BLOWER MOTORS

AIR CONDITIONING SYSTEM

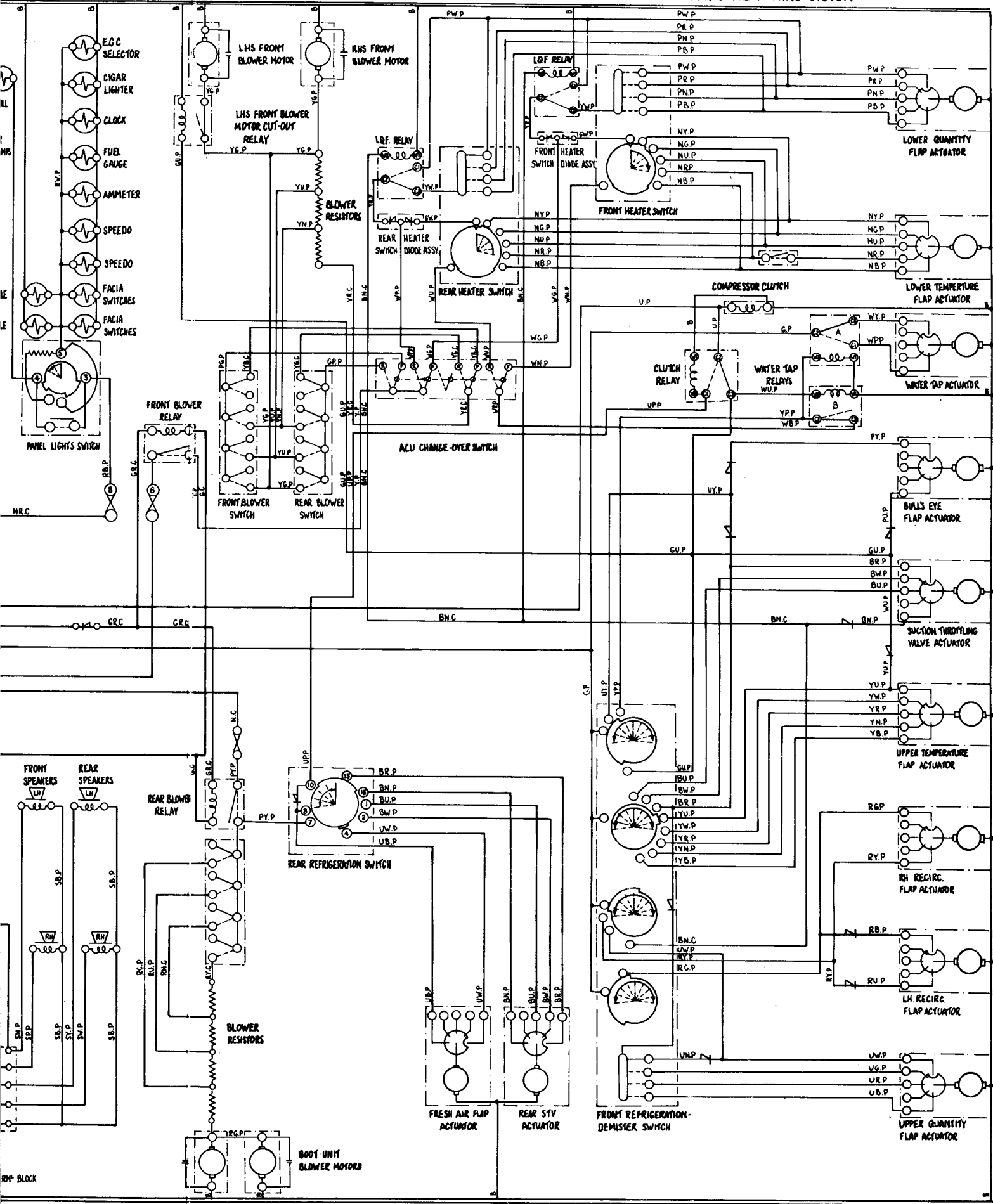

BOOT REFRIGERATION UNIT

PRACTICAL WIRING DIAGRAM

Sheet 6

STARTING AND IGNITION CIRCUIT

For
Rolls-Royce Silver Shadow
and
Bentley T Series

**SALOON AND LONG WHEELBASE NON-
DIVISION CARS FOR USA AND CANADA
FROM CAR SERIAL NUMBERS
22118 AND 22073**

T.S.D. Publication 2476

© Rolls-Royce Motors Limited 1976

"This document is the property of Rolls-Royce Motors Limited and may not be copied or communicated to a third party or used for any purpose other than that for which it is supplied without the express written authority of Rolls-Royce Motors Limited."

"Whilst the information in this document given in good faith based upon the latest knowledge available to Rolls-Royce Motors Limited, Rolls-Royce Motors Limited gives no warranty or representation concerning such information, and such information must not be taken as establishing any contractual or other commitment on the part of Rolls-Royce Motors Limited."

- 1 Exhaust gas recirculation valve (secondary)
- 2 Exhaust gas recirculation valve (primary)
- 3 Air diverter solenoid valve
- 4 Air diverter vacuum switch
- 5 Anti-diesel solenoid valve
- 6 Weakener cut-off thermal switch
- 7 Choke solenoid
- 8 Exhaust gas recirculation solenoid 1
- 9 Earth point
- 10 Exhaust gas recirculation solenoid 2
- 11 Full throttle switch
- 12 Exhaust gas recirculation valve vacuum switch
- 13 Right-hand valance plug
- 14 Choke-on-start relay
- 15 Starter relay
- 16 Ballast resistor
- 17 Ignition coil
- 18 Weakener cut-off solenoid
- 19 Fuel pumps
- 20 Starter motor & relay
- 21 Ignition distributor
- 22 Kick-down solenoid
- 23 Kick-down switch
- 24 Left-hand valance plug
- 25 Right-hand toeboard sockets
- 26 Choke thermal delay switch
- 27 Voltage regulator
- 28 Gearchange actuator
- 29 Left-hand toeboard socket
- 30 Fuel pumps relay
- 31 Ammeter shunt
- 32 Ammeter
- 33 Switchbox
- 34 Column neutral start switch
- 35 Fuseboard

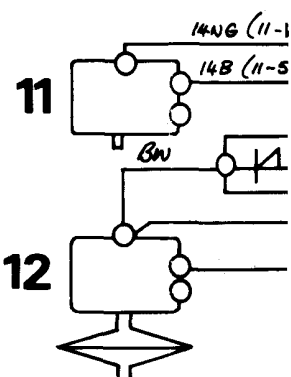
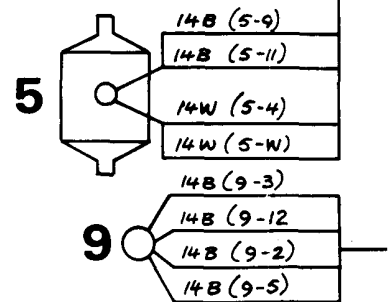
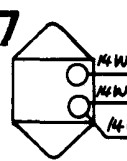
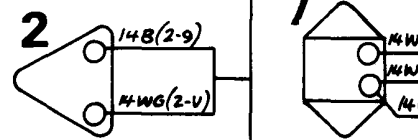
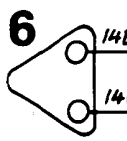
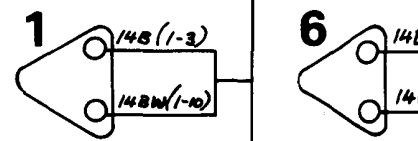
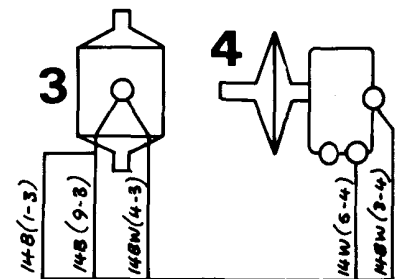
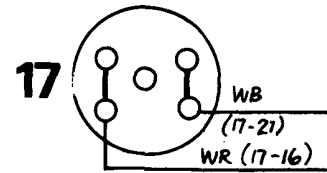
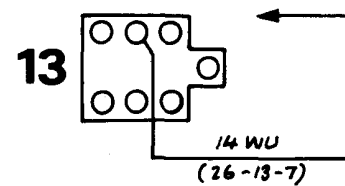

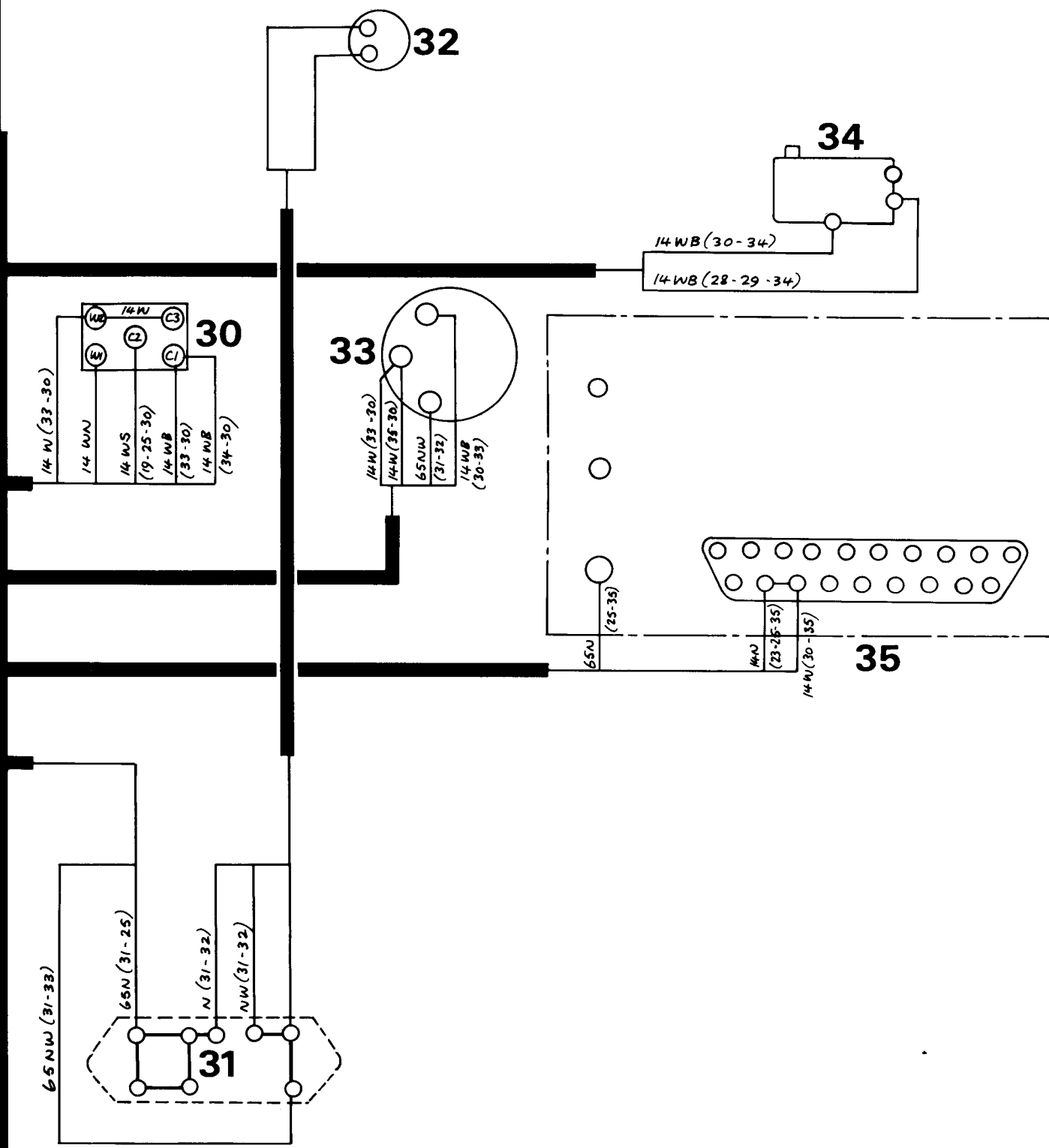

30

33

34

35

32

31

14 WU (33-30)

14 WU

14 WS
(19-25-30)

14 WB
(33-30)

14 WB
(34-30)

65 NW (31-33)

65 N (31-25)

N (31-32)

NW (31-32)

14 WU (33-30)

14 WU (35-30)

65 NW (31-32)

14 WB (30-35)

14 WB (30-34)

14 WB (28-29-34)

65 N (25-35)

14 N (23-25-35)

14 WU (30-35)

PRACTICAL WIRING DIAGRAM

Sheet 7

CHARGING CIRCUIT

For
Rolls-Royce Silver Shadow
and
Bentley T Series

RIGHT-HAND DRIVE SALOON AND LONG WHEELBASE NON-DIVISION CARS FROM CAR SERIAL NUMBERS 22118 AND 22073

T.S.D. Publication 2476

© Rolls-Royce Motors Limited 1976

"This document is the property of Rolls-Royce Motors Limited and may not be copied or communicated to a third party or used for any purpose other than that for which it is supplied without the express written authority of Rolls-Royce Motors Limited."

"Whilst the information in this document given in good faith based upon the latest knowledge available to Rolls-Royce Motors Limited, Rolls-Royce Motors Limited gives no warranty or representation concerning such information, and such information must not be taken as establishing any contractual or other commitment on the part of Rolls-Royce Motors Limited."

- 1 Alternator
- 2 Capacitors
- 3 Starter solenoid
- 4 Right-hand valance socket
- 5 Regulator
- 6 Choke thermal delay unit
- 7 Right-hand toeboard socket
- 8 Relay board earth
- 9 Ammeter shunt
- 10 Switchbox
- 11 Alternator warning lamp
- 12 Ammeter
- 13 Fuseboard
- 14 Battery

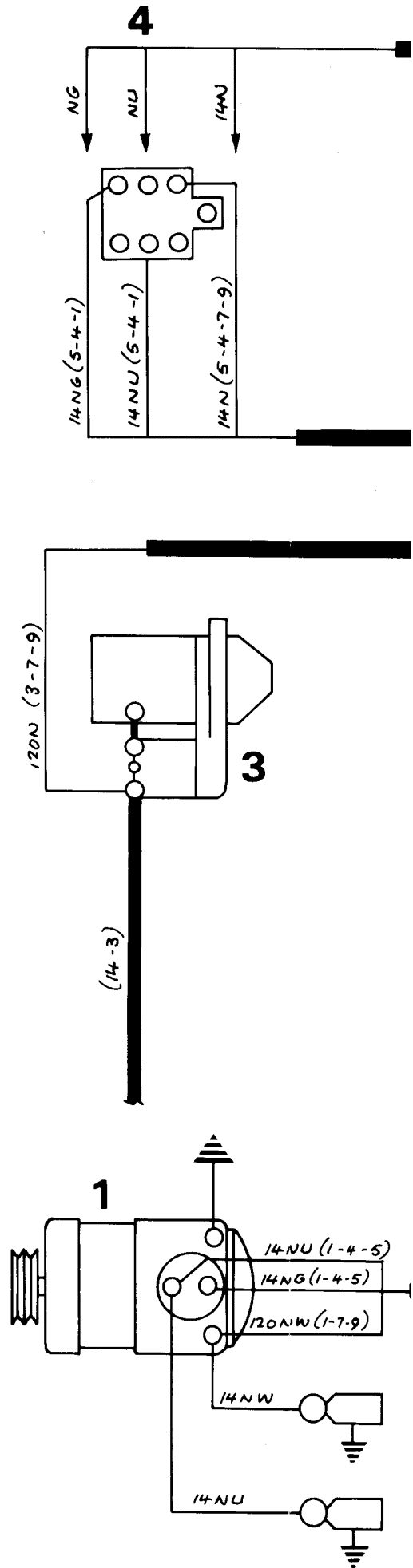

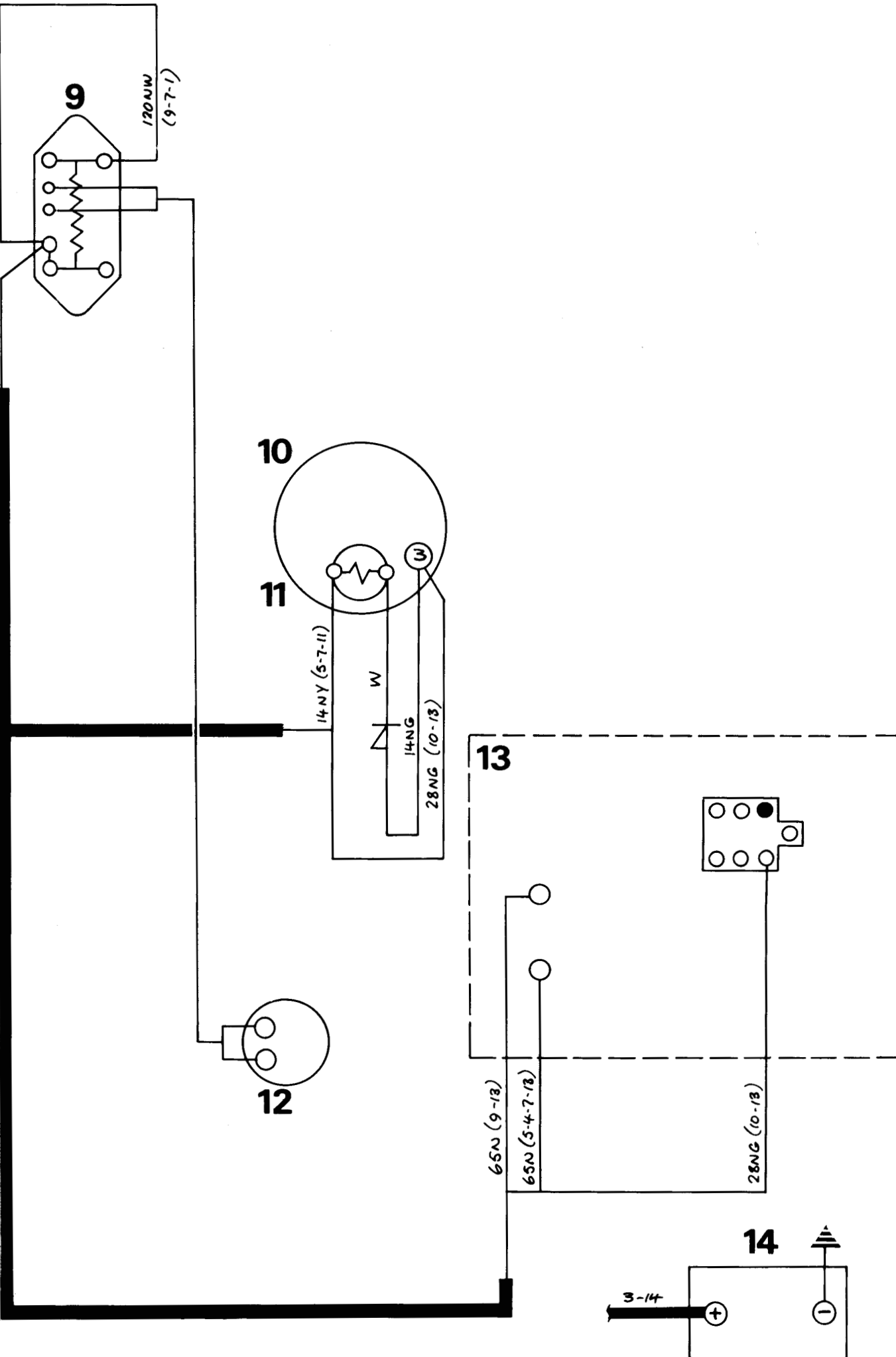

PRACTICAL WIRING DIAGRAM

Sheet 8

EXTERIOR LIGHTING

For
Rolls-Royce Silver Shadow
and
Bentley T Series

RIGHT-HAND DRIVE SALOON AND LONG WHEELBASE NON-DIVISION CARS FROM CAR SERIAL NUMBERS 22118 AND 22073

T.S.D. Publication 2476

© Rolls-Royce Motors Limited 1976

"This document is the property of Rolls-Royce Motors Limited and may not be copied or communicated to a third party or used for any purpose other than that for which it is supplied without the express written authority of Rolls-Royce Motors Limited."

"Whilst the information in this document given in good faith based upon the latest knowledge available to Rolls-Royce Motors Limited. Rolls-Royce Motors Limited gives no warranty or representation concerning such information, and such information must not be taken as establishing any contractual or other commitment on the part of Rolls-Royce Motors Limited."

- 1 Right-hand side/flasher lamp
- 2 Right-hand headlamp (outer)
- 3 Right-hand headlamp (inner)
- 4 Right-hand snap connector block
- 5 Right-hand foglamp
- 6 Left-hand foglamp
- 7 Left-hand headlamp (inner)
- 8 Left-hand headlamp (outer)
- 9 Left-hand side/flasher lamp
- 10 Left-hand snap connector block
- 11 Right-hand front side marker lamp
- 12 Right-hand spring pot earth
- 13 Right-hand valance earth
- 14 Right-hand flasher repeater
- 15 Stoplamp switch
- 16 Head flash relay
- 17 Left-hand front side marker lamp
- 18 Left-hand spring pot earth
- 19 Left-hand valance earth
- 20 Left-hand flasher repeater
- 21 Right-hand toeboard sockets
- 22 Relay printed circuit board
- 23 Gearchange actuator
- 24 Left-hand toeboard sockets
- 25 Hazard warning fuse
- 26 Ammeter shunt
- 27 Hazard flasher relay
- 28 Hazard flasher unit
- 29 Flasher switch socket
- 30 Dipswitch
- 31 Rear foglamp relay
- 32 Rear foglamp fuses
- 33 Switchbox
- 34 Speedometer
- 35 Right-hand 'A' body socket
- 36 Fuseboard
- 37 Console sockets
- 38 Left-hand 'A' post body sockets
- 39 Right-hand boot earth
- 40 Rear foglamp warning lamp/switch
- 41 Hazard warning switch
- 42 Left-hand boot earth
- 43 Petrol filler door solenoid
- 44 Right-hand side marker lamp
- 45 Boot socket
- 46 Tunnel earth
- 47 Dimming relay connections
- 48 Stoplamp relay socket
- 49 Left-hand rear side marker lamp
- 50 Right-hand rear lamp
- 51 Number plate loom connector
- 52 Right-hand rear foglamp
- 53 Right-hand number plate lamp
- 54 Left-hand number plate lamp
- 55 Left-hand rear foglamp
- 56 Left-hand rear lamp
- 57 Right-hand 'A' post upper earth

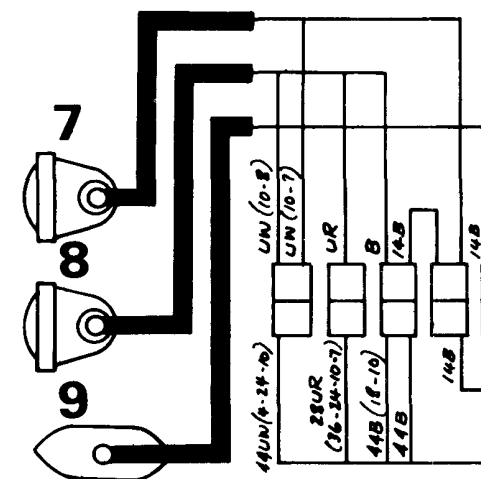
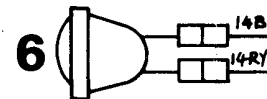
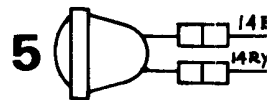
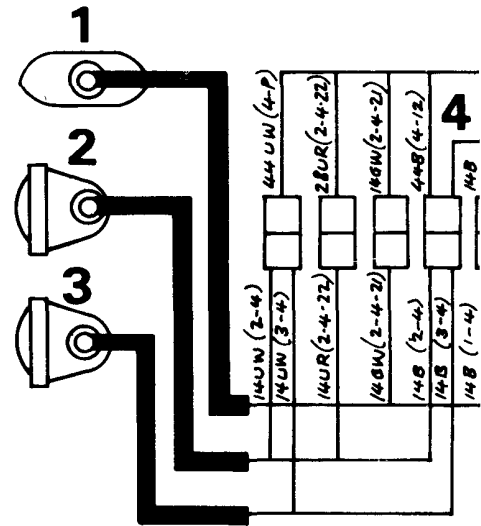

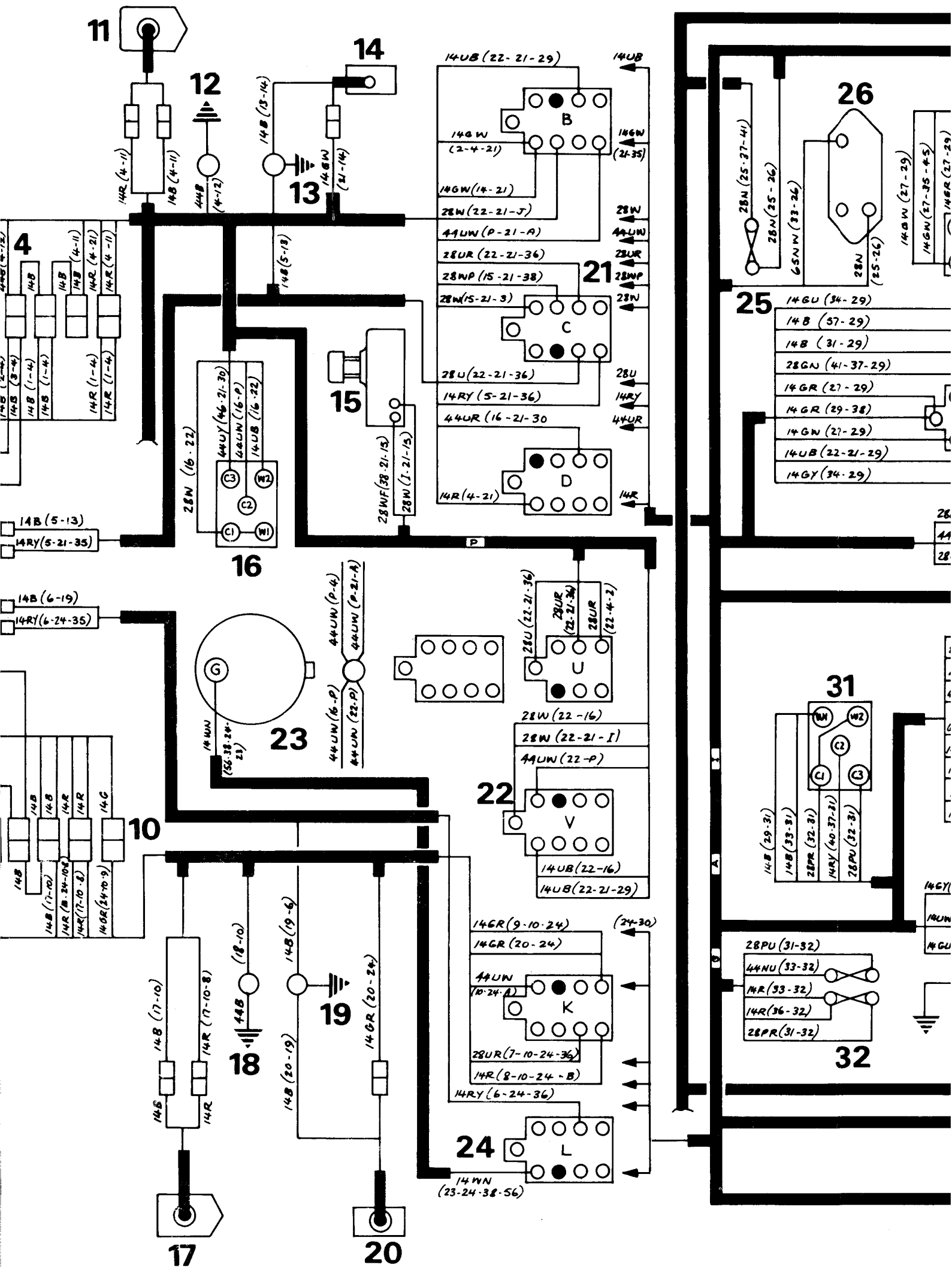

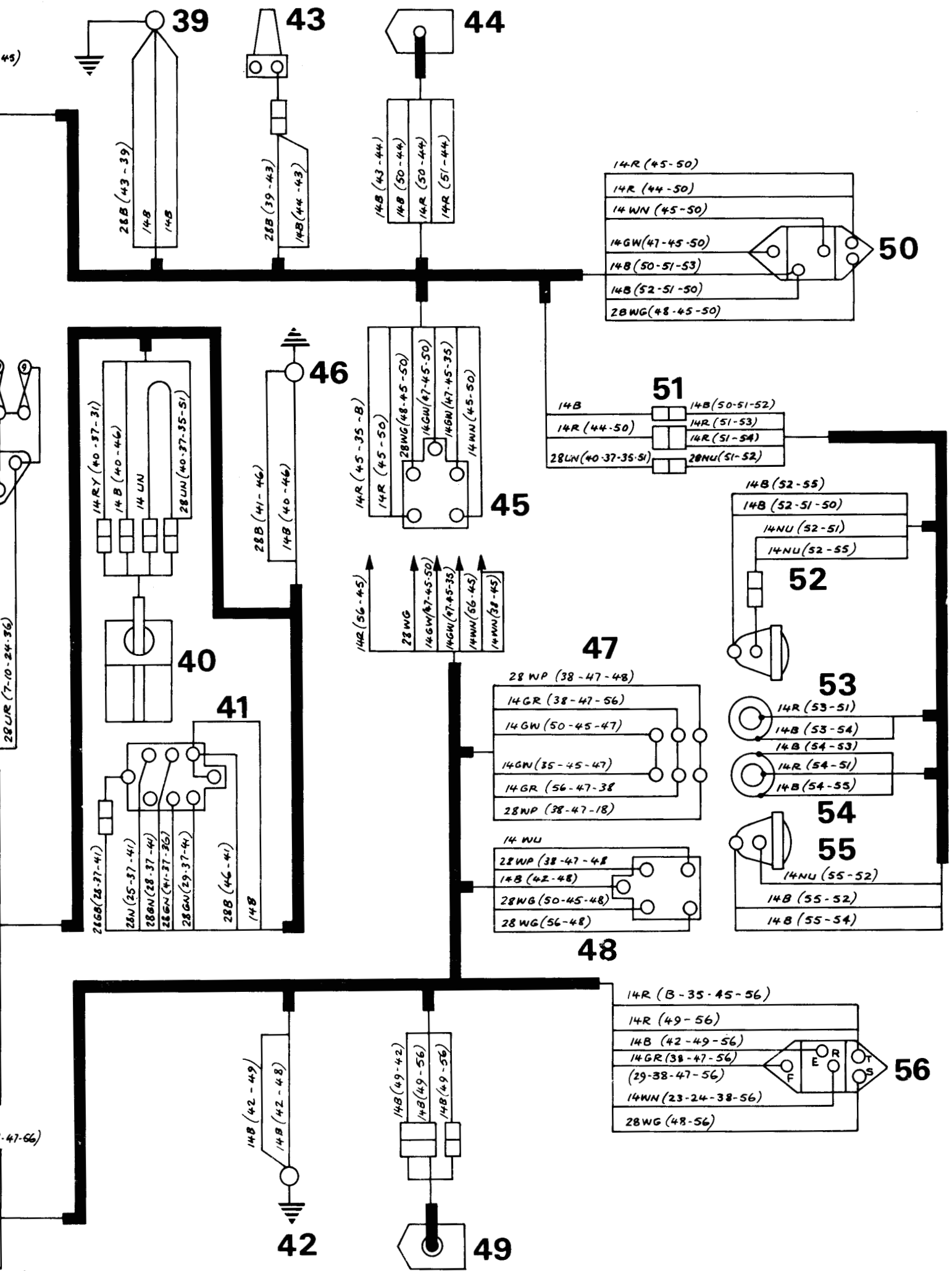

PRACTICAL WIRING DIAGRAM

Sheet 9

INTERIOR LIGHTING

For
Rolls-Royce Silver Shadow
and
Bentley T Series

SALOON AND LONG WHEELBASE NON-DIVISION CARS FOR USA AND CANADA FROM CAR SERIAL NUMBERS 22118 AND 22073

T.S.D. Publication 2476

© Rolls-Royce Motors Limited 1976

"This document is the property of Rolls-Royce Motors Limited and may not be copied or communicated to a third party or used for any purpose other than that for which it is supplied without the express written authority of Rolls-Royce Motors Limited."

"Whilst the information in this document given in good faith based upon the latest knowledge available to Rolls-Royce Motors Limited. Rolls-Royce Motors Limited gives no warranty or representation concerning such information, and such information must not be taken as establishing any contractual or other commitment on the part of Rolls-Royce Motors Limited."

- 1 Right-hand snap connector block
- 2 Underbonnet lamp switch
- 3 Underbonnet lamp
- 4 Right-hand front earth
- 5 Relay printed circuit board
- 6 Right-hand toeboard sockets
- 7 Right-hand 'A' post earth
- 8 Interior lamps delay unit
- 9 Interior lamps delay relay
- 10 Transistor unit
- 11 Speed control panel
- 12 Zener diode
- 13 Fuse connector
- 14 Resistor unit
- 15 Right-hand front door switch
- 16 Right-hand interior lamp switch (front)
- 17 Cubby box lamp switch
- 18 Cubby box lamp
- 19 Instrument panel earth
- 20 Right-hand facia switch lamp
- 21 Panel lamp switch
- 22 Clock
- 23 Left-hand facia switch lamp
- 24 Fuel/Oil level gauge
- 25 Ammeter
- 26 Seat belt diode
- 27 Left-hand front door switch
- 28 Instrument link loom connection
- 29 Speedometer
- 30 Switchbox
- 31 Right-hand 'A' post sockets
- 32 Console sockets
- 33 Gearchange illumination
- 34 Fuseboard
- 35 Left-hand 'A' post sockets
- 36 Right-hand front interior lamp
- 37 Right-hand rear door switch
- 38 Console illumination
- 39 Cigar lighter
- 40 Hazard warning switch
- 41 Left-hand rear door switch
- 42 Left-hand front interior lamp
- 43 Right-hand rear interior lamp
- 44 Right-hand reading lamp switch
- 45 Boot lamp switch
- 46 Tunnel earth
- 47 Boot lamp
- 48 Left-hand rear interior lamp
- 49 Left-hand boot earth
- 50 Left-hand reading lamp switch
- 51 Right-hand boot earth

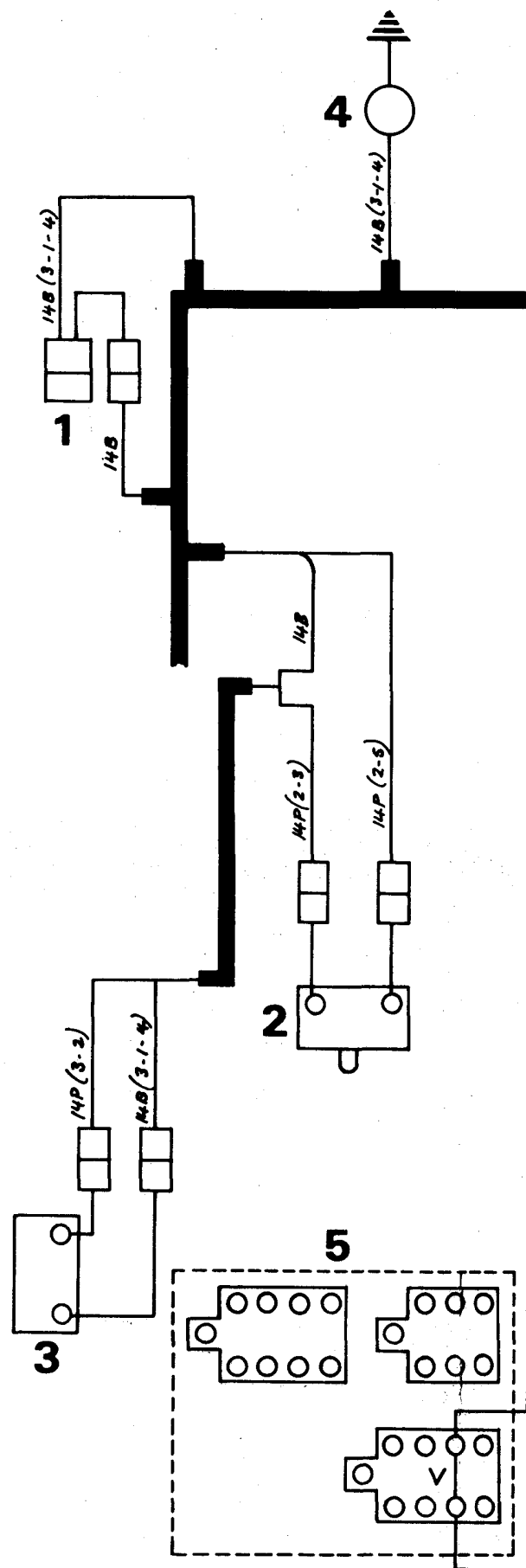

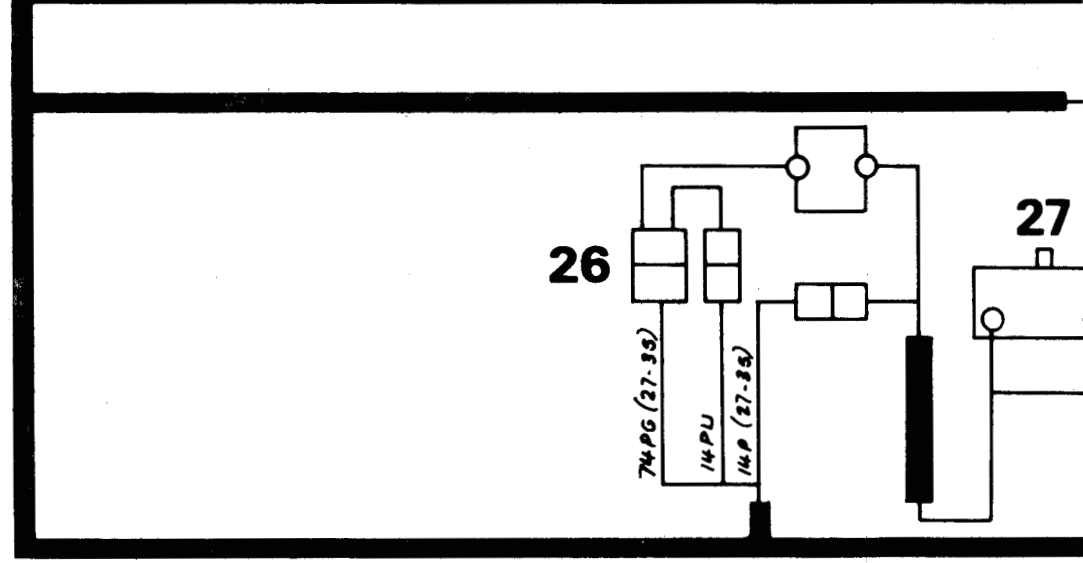
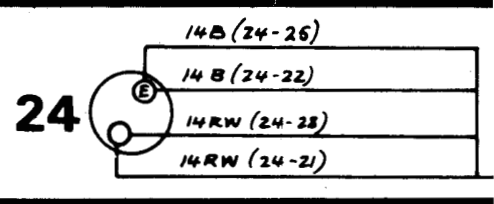
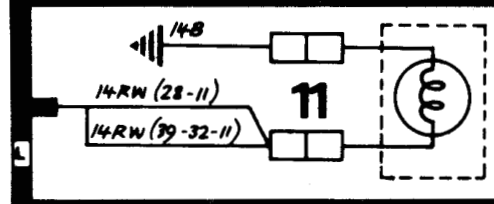
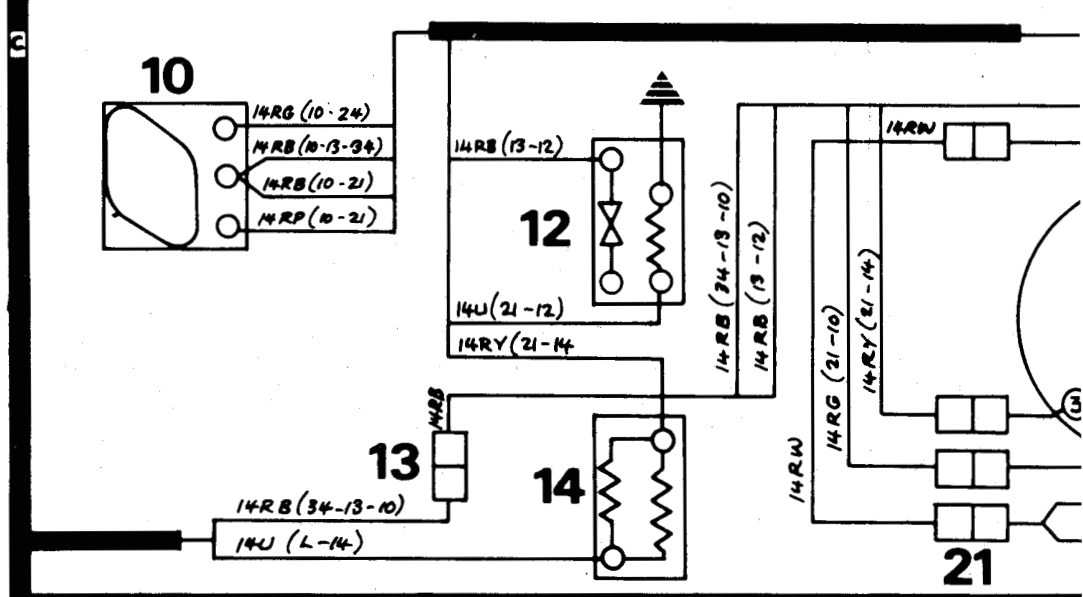
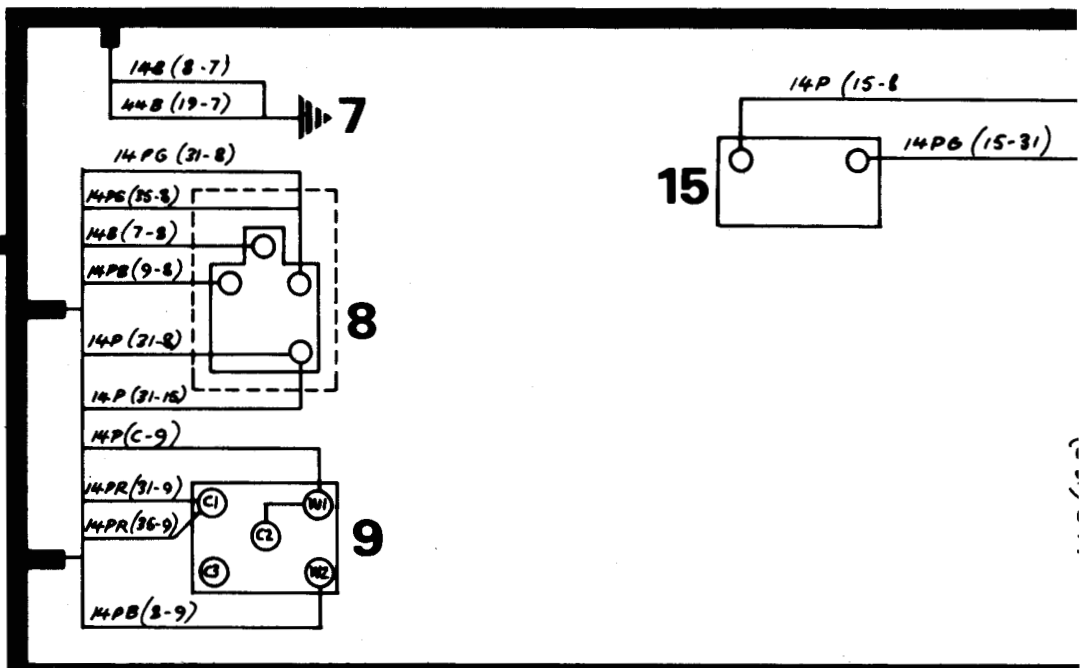
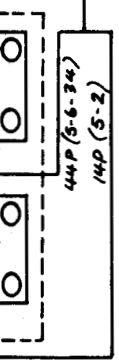
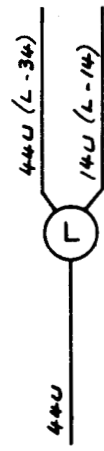
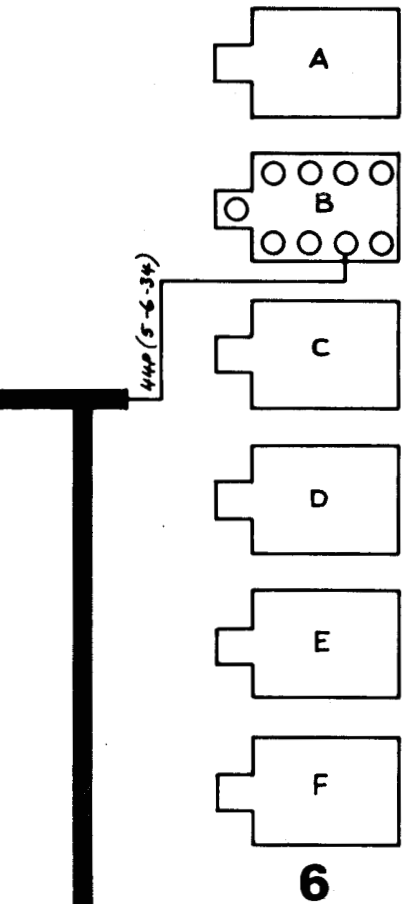

PRACTICAL WIRING DIAGRAM

Sheet 10

WARNING LAMPS AND INSTRUMENTS

For
Rolls-Royce Silver Shadow
and
Bentley T Series

SALOON AND LONG WHEELBASE NON-DIVISION CARS FOR USA AND CANADA FROM CAR SERIAL NUMBERS 22118 AND 22073

T.S.D. Publication 2476

© Rolls-Royce Motors Limited 1976

"This document is the property of Rolls-Royce Motors Limited and may not be copied or communicated to a third party or used for any purpose other than that for which it is supplied without the express written authority of Rolls-Royce Motors Limited."

"Whilst the information in this document given in good faith based upon the latest knowledge available to Rolls-Royce Motors Limited, Rolls-Royce Motors Limited gives no warranty or representation concerning such information, and such information must not be taken as establishing any contractual or other commitment on the part of Rolls-Royce Motors Limited."

- 1 Right-hand front earth
- 2 Right-hand snap connector block
- 3 Coolant probe
- 4 Oil pressure switch
- 5 Brake accumulator pressure switches
- 6 Brake fluid level sensors
- 7 Washer bottle probe
- 8 High metal temperature switch
- 9 Oil sump unit
- 10 Left-hand valance sockets
- 11 Right-hand toeboard sockets
- 12 Left-hand toeboard sockets
- 13 Washer fluid level amplifier
- 14 Seat belt warning loom connector
- 15 Key warning relay
- 16 Key warning buzzer
- 17 Left-hand 'A' post earth
- 18 Right-hand 'A' post earth
- 19 Diode connector
- 20 Warning lamp test board
- 21 Ammeter shunt
- 22 High metal temperature buzzer
- 23 Fuel/Oil gauge
- 24 Ammeter
- 25 Seat belt warning diode assembly
- 26 Left-hand front door switch
- 27 Instrument panel earth
- 28 Right-hand warning lamp cluster
- 29 Seat belt warning lamps
- 30 Clock
- 31 Left-hand warning lamp cluster
- 32 Fuel/Oil level test switch
- 33 High metal temperature test switch
- 34 Speedometer
- 35 Parking brake switch
- 36 Switchbox
- 37 Seat belt warning control unit
- 38 Fuseboard
- 39 Right-hand 'A' post body socket
- 40 Left-hand 'A' post body socket
- 41 Right-hand boot earth
- 42 Fuel tank unit
- 43 Seat belt clasp
- 44 Stoplamp relay socket
- 45 Radio

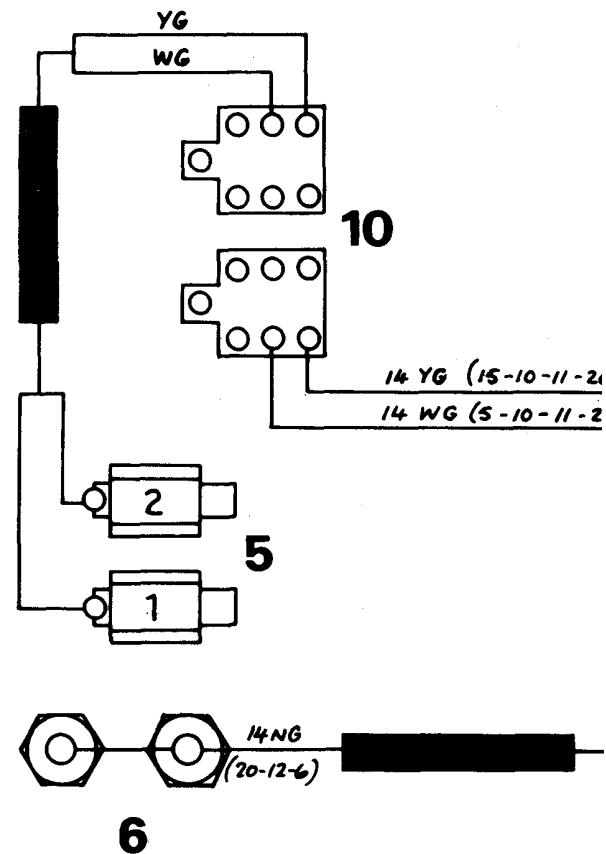
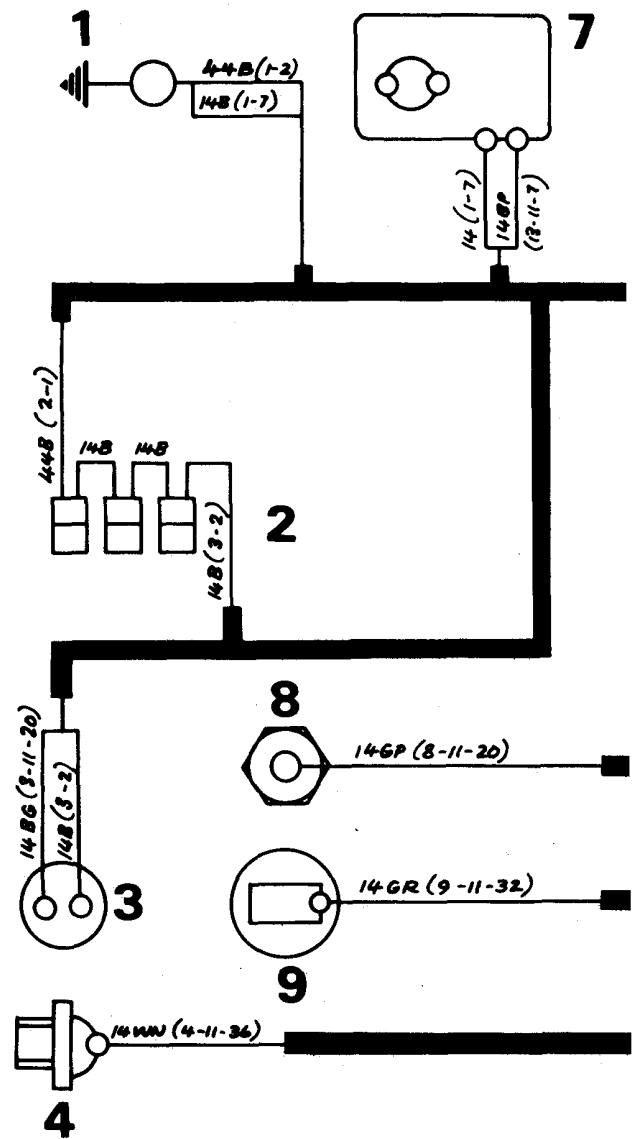

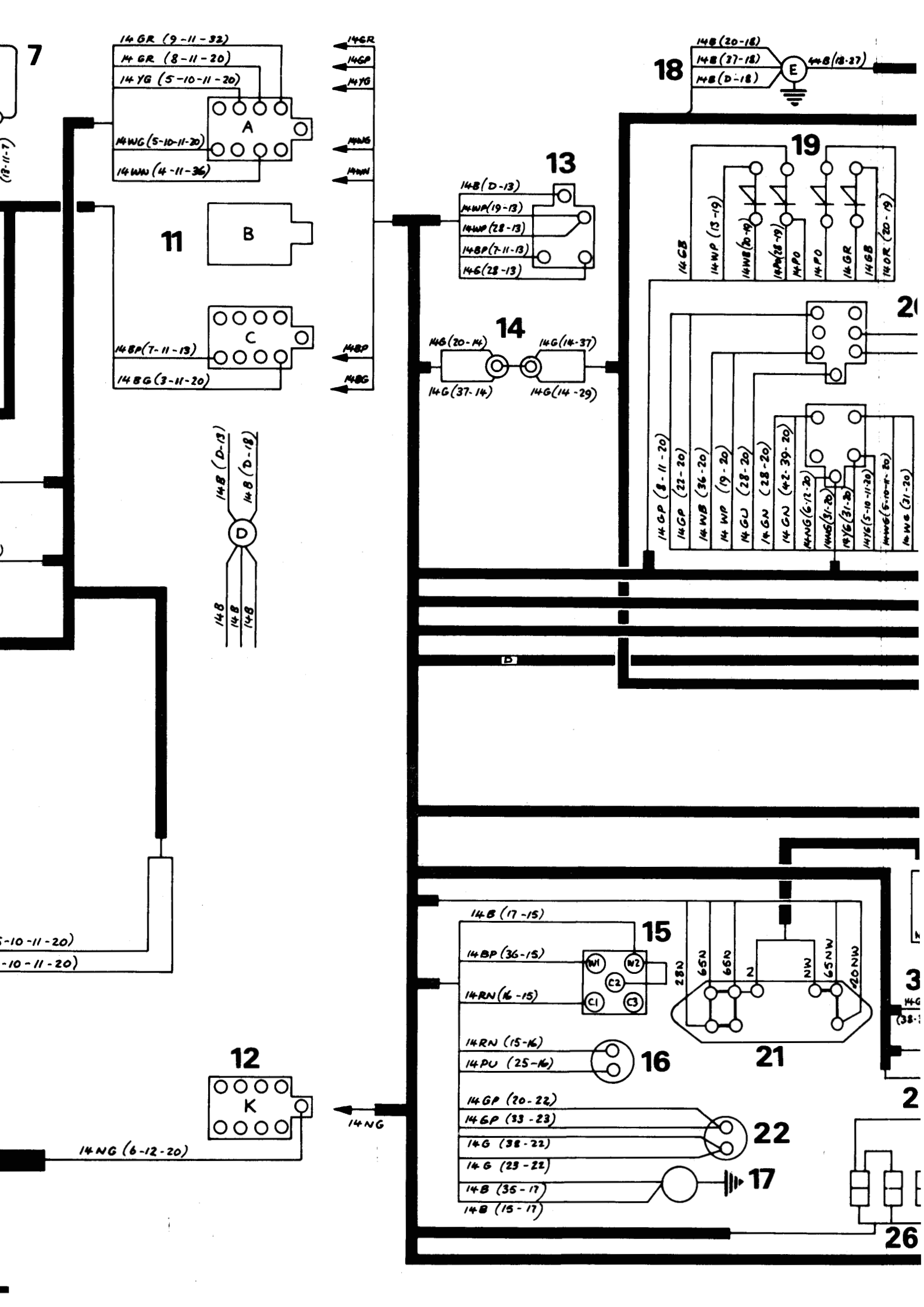

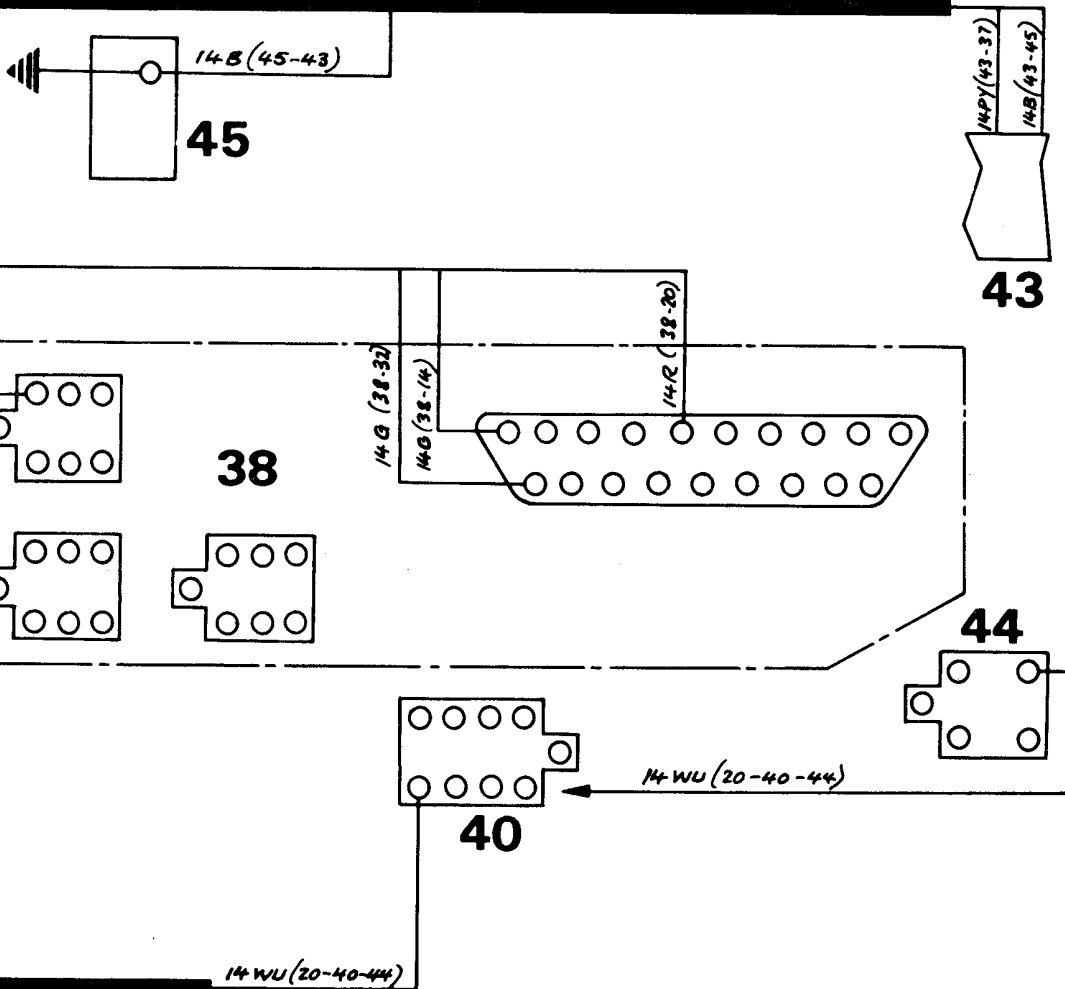
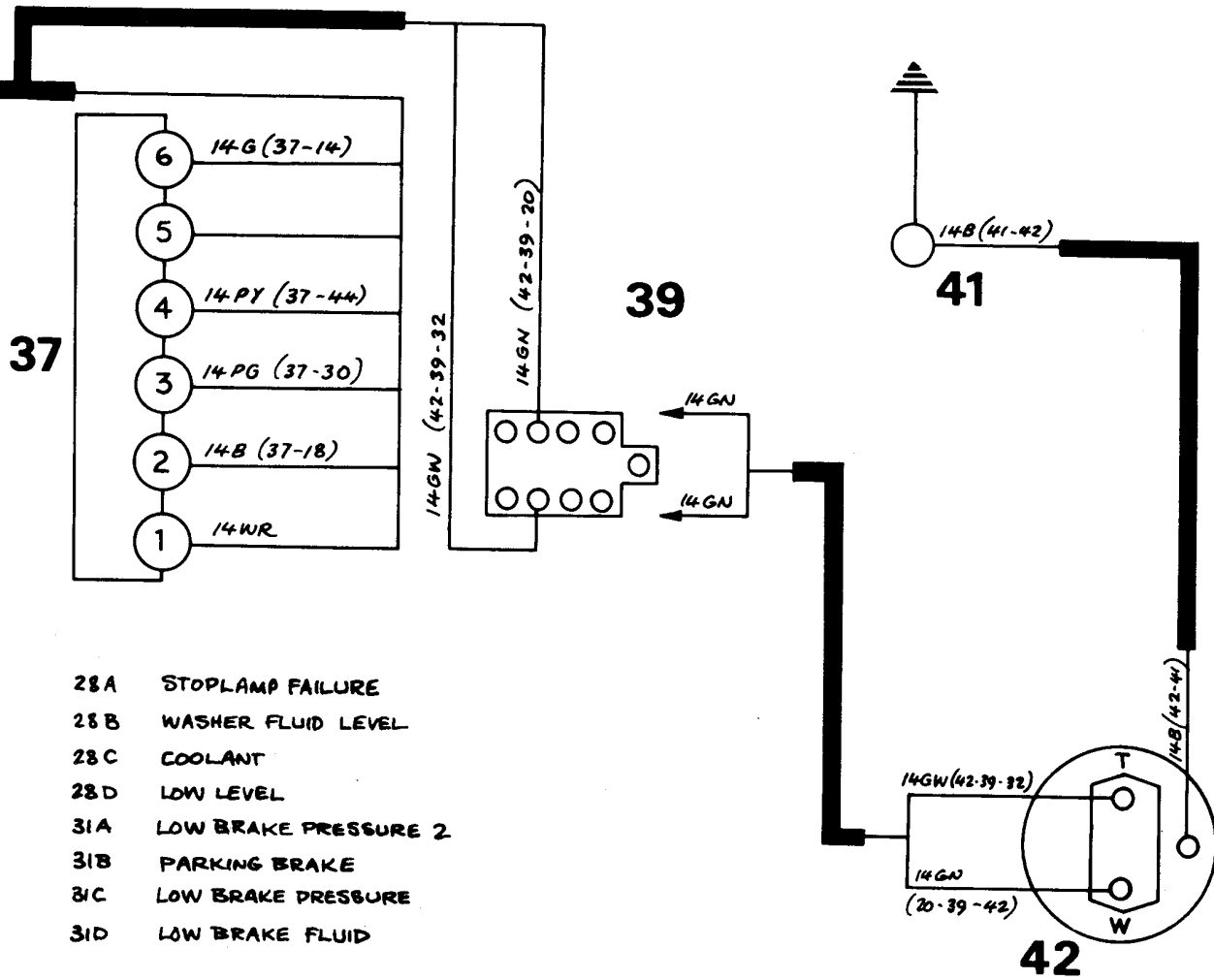

Section 17

Rolls-Royce and Bentley
Corniche with Automatic
Air Conditioning Unit
(Sheets 1 and 2)

Printed in England

November 1975

T.S.D. 2476

THEORETICAL WIRING DIAGRAM

Sheet 1

For
Rolls-Royce Corniche Convertible
and
Bentley Corniche Convertible

**ALL CARS FROM
SERIAL NUMBER 22583**

T.S.D. Publication 4151

© Rolls-Royce Motors Limited 1975

"This document is the property of Rolls-Royce Motors Limited and may not be copied or communicated to a third party or used for any purpose other than that for which it is supplied without the express written authority of Rolls-Royce Motors Limited."

"Whilst the information in this document given in good faith based upon the latest knowledge available to Rolls-Royce Motors Limited. Rolls-Royce Motors Limited give no warranty or representation concerning such information, and such information must not be taken as establishing any contractual or other commitment on the part of Rolls-Royce Motors Limited."

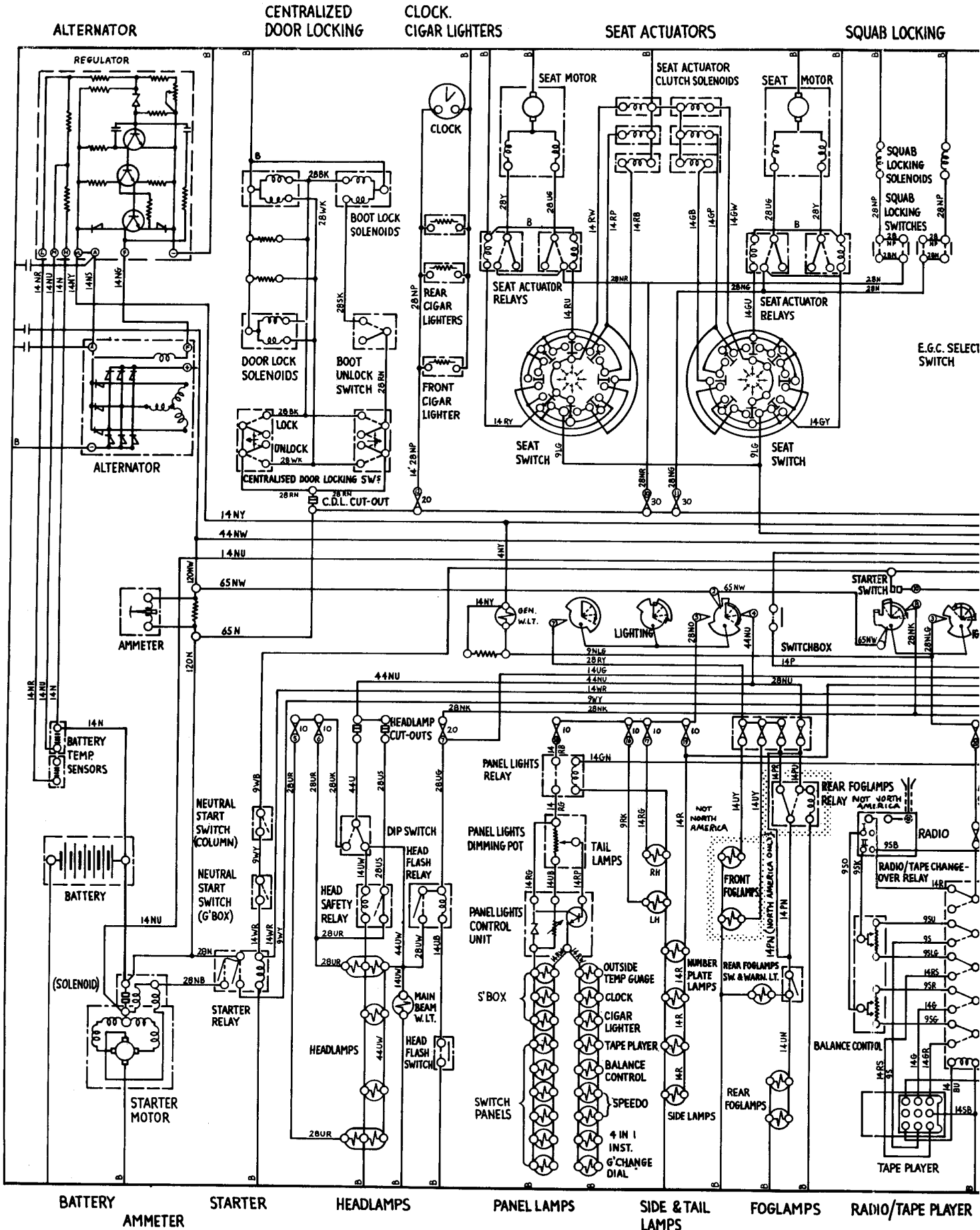

ALTERNATOR

CENTRALIZED DOOR LOCKING

CLOCK, CIGAR LIGHTERS

SEAT ACTUATORS

SQUAB LOCKING

BATTERY

AMMETER

STARTER

HEADLAMPS

PANEL LAMPS

SIDE & TAIL LAMPS

FOGLAMPS

RADIO/TAPE PLAYER

E.G.C. SELECT SWITCH

KING GEARCHANGE WINDOW LIFTS HORNS INTERIOR LIGHTS DIRECTION IN HAZARD WARN REVERSE LAMP

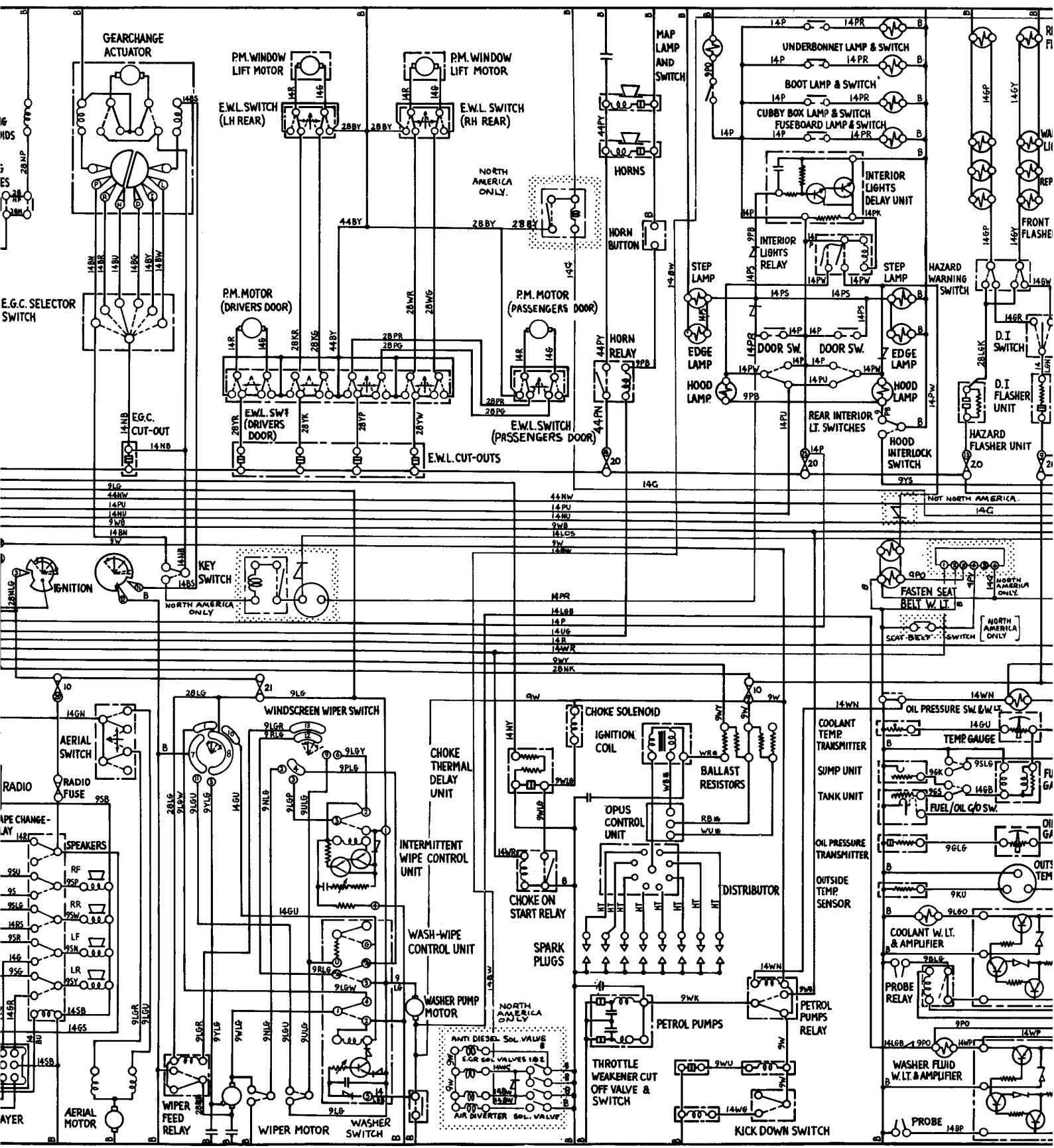

WINDSCREEN WIPERS & WASHER IGNITION PETROL PUMPS KICK DOWN THROTTLE WEAKENER CUT OFF VALVE

ITEMS MARKED
THUS ONLY FITTED
AS STATED

DIRECTION INDICATORS

HAZARD WARNING

REVERSE LAMPS

STOPLAMPS

SPEED CONTROL

HOOD LIFT UNIT

AUTOMATIC AIR CONDITIONING UNIT

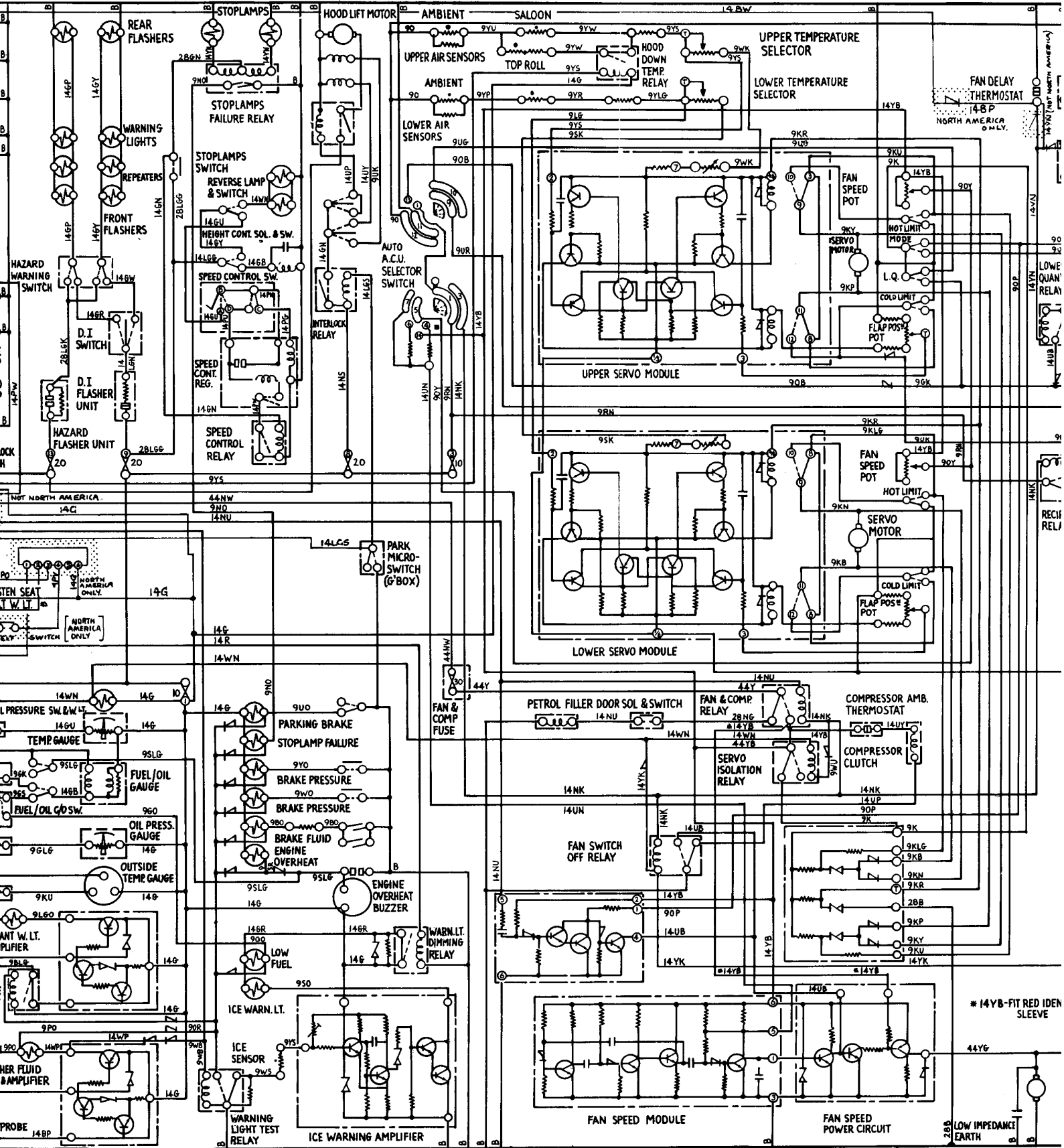

GAUGES & WARNING LIGHTS

PETROL FILLER DOOR

SERVO TEST POINTS MARKED THUS

ATORS

STOPLAMPS
SPEED CONTROL HOOD LIFT UNIT

AUTOMATIC AIR CONDITIONING UNIT

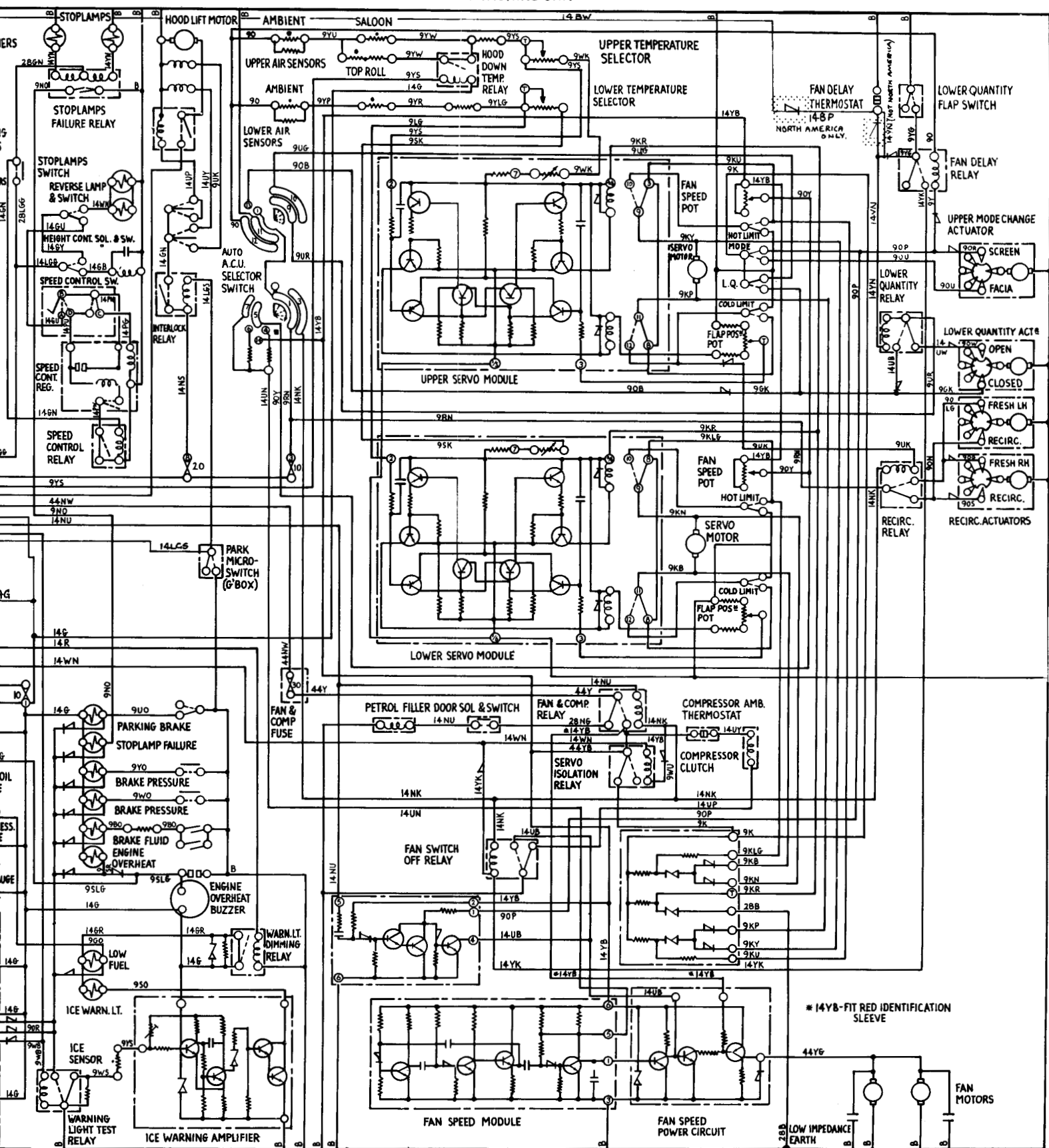

AGES & WARNING LIGHTS

PETROL FILLER DOOR

SERVO TEST POINTS
MARKED THUS

* 14YB-FIT RED IDENTIFICATION
SLEEVE

LOW IMPEDANCE
EARTH

THEORETICAL WIRING DIAGRAM

Sheet 2

For
Rolls-Royce Corniche Saloon
and
Bentley Corniche Saloon

**ALL CARS FROM
SERIAL NUMBER 22583**

T.S.D. Publication 4160

© Rolls-Royce Motors Limited 1976

"This document is the property of Rolls-Royce Motors Limited and may not be copied or communicated to a third party or used for any purpose other than that for which it is supplied without the express written authority of Rolls-Royce Motors Limited."

"Whilst the information in this document given in good faith based upon the latest knowledge available to Rolls-Royce Motors Limited. Rolls-Royce Motors Limited gives no warranty or representation concerning such information, and such information must not be taken as establishing any contractual or other commitment on the part of Rolls-Royce Motors Limited."

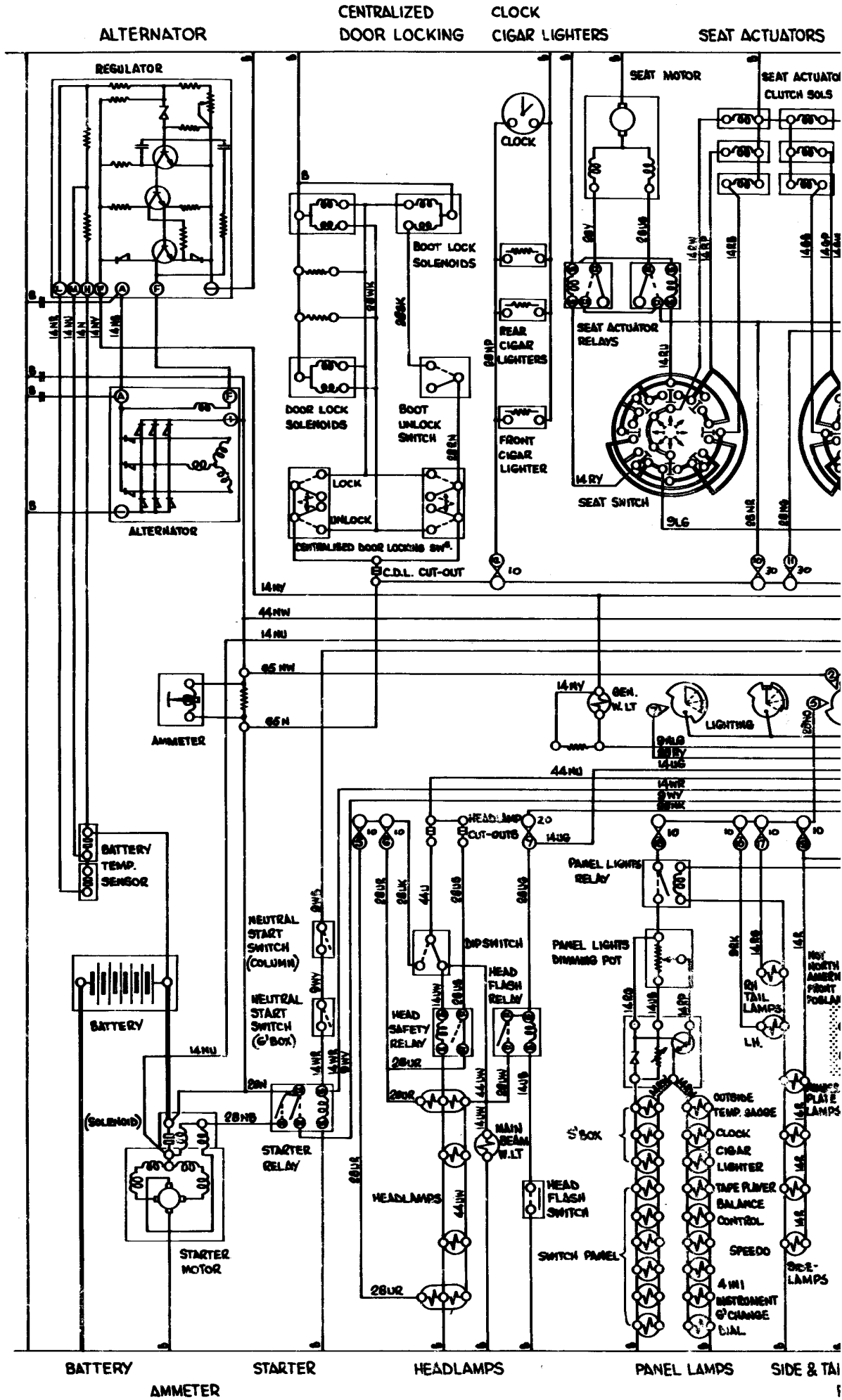

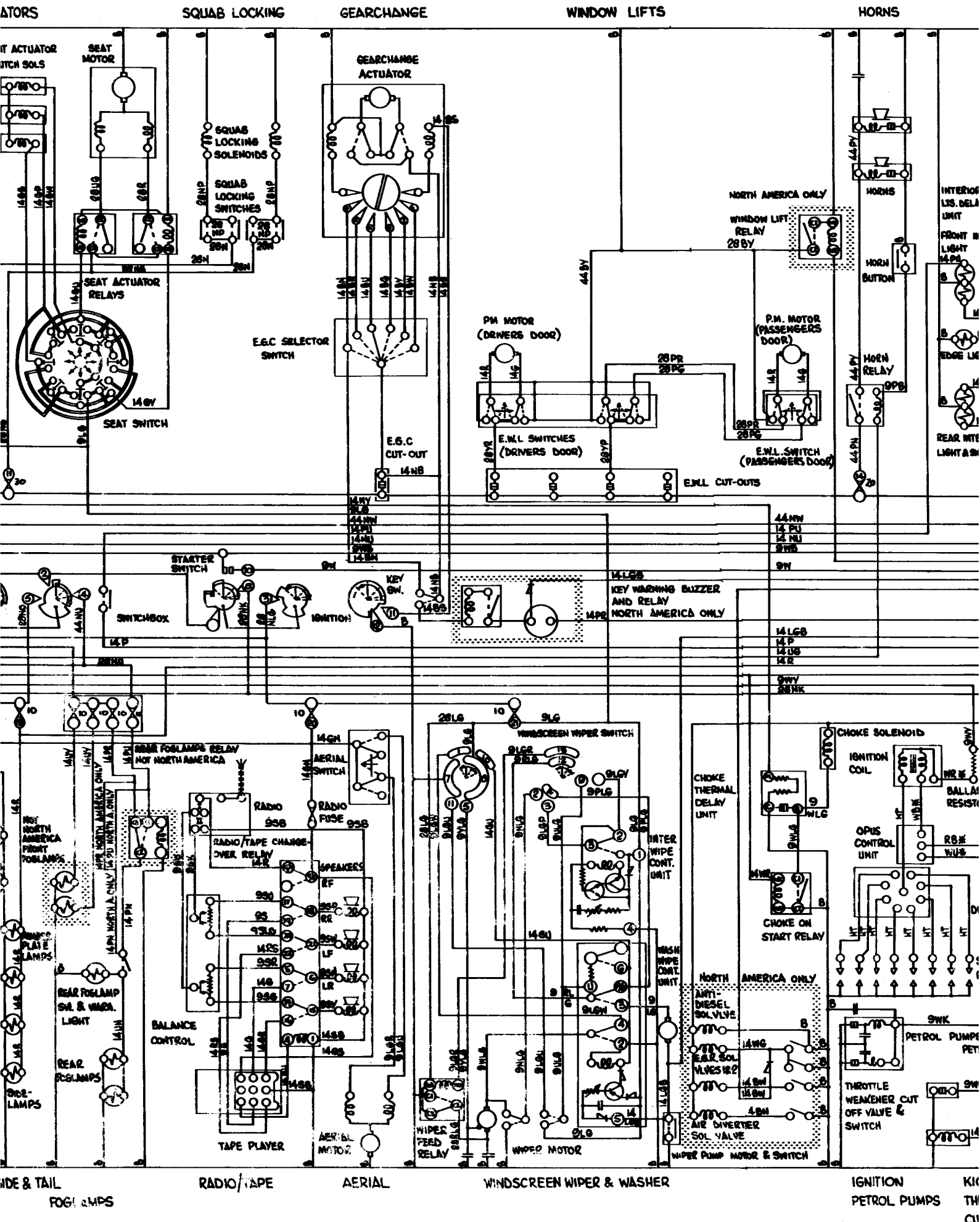

FRONT & REAR FOG LAMPS
 RADIO/TAPE
 AERIAL
 WINDSCREEN WIPER & WASHER
 IGNITION
 PETROL PUMPS

AUTOMATIC AIR CONDITIONING

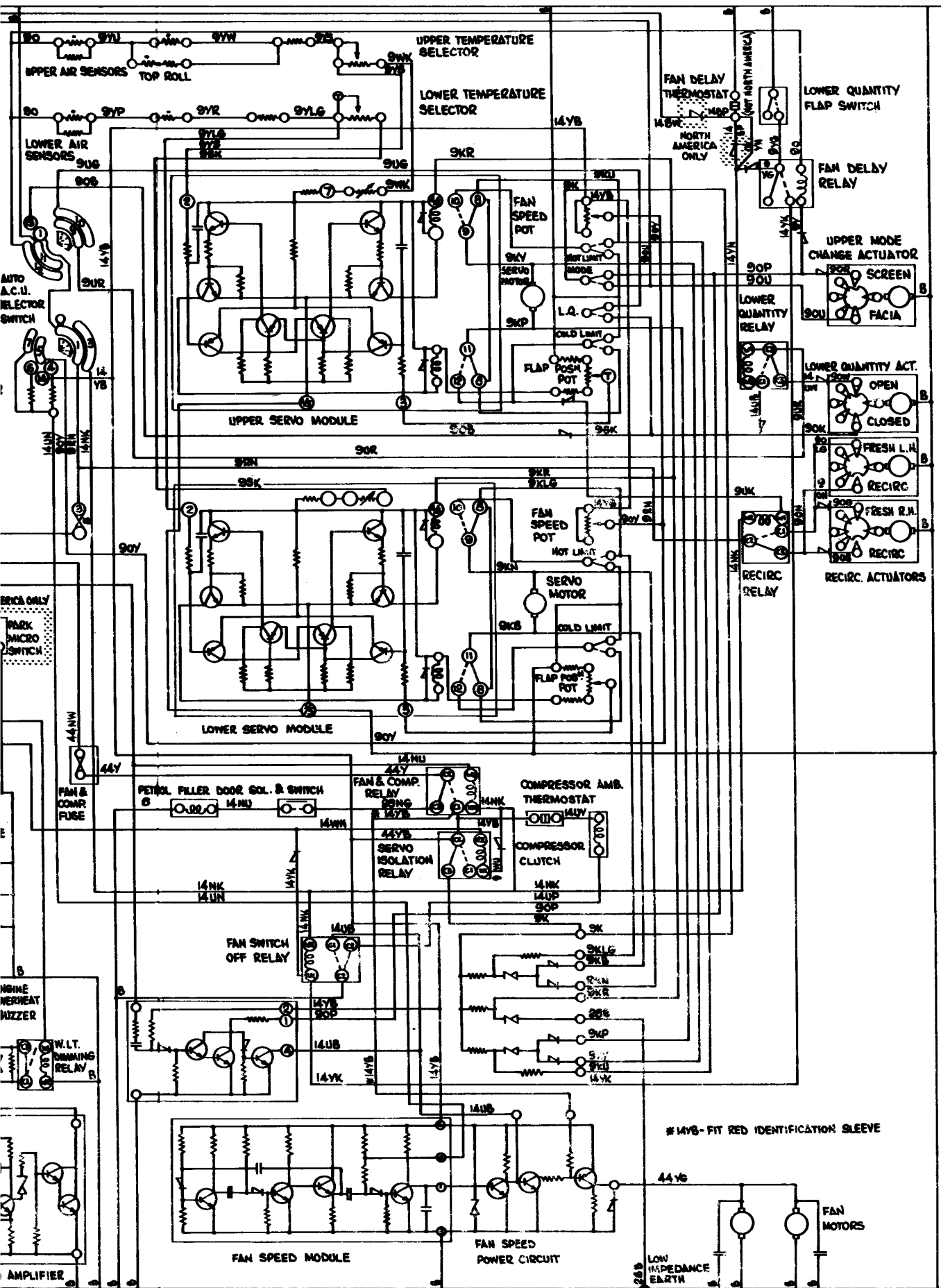

ITEMS MARKED THUS ONLY FITTED AS STATED

PETROL FILLER DOOR

⊕ SERVO TEST POINTS MARKED THUS

#14YB-FIT RED IDENTIFICATION SLEEVE