

# TEE ONE TOPICS

---

---

Number 10 January, 2002

## Disclaimer

The Tee One movement is not in any way affiliated nor associated with the Rolls-Royce Owners' Club of Australia nor any other organisation. Its aims are to spread knowledge and information about proper motor cars that would not normally appear in club journals nor any other publications readily available to the public. The knowledge of owners and enthusiasts that is shared in these gatherings is offered/received without any form of guarantee or authority. Individuals are solely responsible for their own cars and actions and the use to which they put the information gained.

## FOR THE LAST TIME

Despite the above I will reluctantly comment on an offering in the last issue of Praeclarvm which I read with some disbelief and then sat down and penned the following in reply. But given that our efforts are quite strongly resented in many quarters of the Club I decided against giving editor/s the opportunity of snubbing my response. But since most of my readers seem to be a captive audience I offer the words for your consideration.

“As I recall, it was King Canute, a monarchic ancient of the emerald isles who was advised by his followers that he was so powerful he could direct the tides of the oceans. Apparently he wisely tested the waters and found this was not so. Presumably he was then able to adjust his ambitions, recognise his limitations and get on with the business of ruling. The analogy I seek to draw is to the persisting attitude of some members to the new arrangements for the manufacture of Rolls-Royce and Bentley motor cars.

I suspect that had Volkswagen and BMW not stepped in, these two marques would have gone to the graveyard in company with so many others, particularly those from the British motoring scene. Only corporations the size of these rescuers would have the resources to continue production. Yet their detractors carp about the authenticity of the new cars, the location of their manufacture and speculate on the judgements of Royce and Rolls if they were available for consultation.

Not only is this arrant nonsense it must surely be seen as gross ingratitude for the efforts made to date by the new companies. There is even a move to ban the new cars from future membership of this Club!!!! Where does this egotism come from? We are not an exclusive club nor are the members of any notable common distinction. We just happen to like Rolls-Royce cars and like driving them. Very very few of us have ever or will ever buy a new Rolls-Royce or Bentley, nor have the pleasure of laying down its specifications, so our posturing about its future lineage is a little on the scale of the Peter Sellers' classic *“The Mouse that Roared”*.

As to design philosophies and quality of manufacture it would be invidious to make comparisons. But few would disagree that the bottom line in a successful car venture is profitability. The new companies are both eminently successful and not given to rescuing nostalgic icons however precious they may seem. If they have judged that the ‘venerable 6.75 litre V-8’ is no longer the unit to carry future cars into the market, make a profit and consequently continue the Marques, then surely they are in a better position than I and my fellow members are to make such a judgement.

As to the views of our founder ghosts; Charles Rolls, from my reading he was a realist and I think he will be applauding the new arrangements. Henry Royce? Undoubtedly his is a saddened ghost; sad that things have come to this. But the blight that has killed so many other prestigious British names is not impressed with nostalgic posturing about past perceived glories; nor does the stock market warm to struggling companies trying to produce something they are incapable of manufacturing through the lack of resources.

I understand that Volkswagen has already provided for the present cars in the servicing and manufacture of parts. That is surely a very positive move and one, dare I say it, for which we should be grateful. The new Rolls-Royce, albeit made by BMW is reportedly a magnificent car hopefully able to wear the world-famous grille and mascot without the slightest trace of self-consciousness.

As to the quibbling over the admission of the 'new' cars to the Club, this is surely a prime example of fatuous posturing. We should be so lucky that the Club survives any appreciable distance into the new millennium and if it can be augmented by the 'new' cars we just might survive into the next century.

Finally, if readers want to exercise their brains over the new arrangements, try thinking of the future name of our Club which may have to be the Rolls-Royce and Bentley Owner's Club of Australia. But perhaps the Bentley Drivers' Club might have other ideas."

## MAN THE PUMPS!

Hot weather, age and LRP are probably all contributing to failure-to-proceed situations for our proper motor cars. Gone are the days of the old Volkswagen where the fuel drained down from the tank sitting just under the front scuttle, into the carburettor, the Autovac which were most reliable until odd bits started wearing out and the venerable Ghost which pressurised their tanks through the exhaust system. Most if not all modern cars now use electric pumps particularly if they have fuel injection. Looking through my old Dykes Automobile Encyclopedia circa 1948 there is not one mention of an electric fuel pump so presumably they were an unknown gadget in Nprth America in the first half of the last century.

Rolls-Royce have used SU electric fuel pumps since before the war (I think the first model to use

them was the 25/30 HP – perhaps someone can correct my ignorance) and continued their use until the Silver Spirit switched to the rotary pump – still electric but entirely different in operation and output. Lloyd Missen must surely have earned the accolade of coal face experience with these gadgets as he apparently nursed his Silver Dawn across the Nullabor with faltering pumps and actually overhauled them on the side of the highway. Such journeys are apocryphal and perhaps he may care to put the account in these pages for the benefit of our descendants. Some years ago I found myself driving a Silver Cloud II through our now

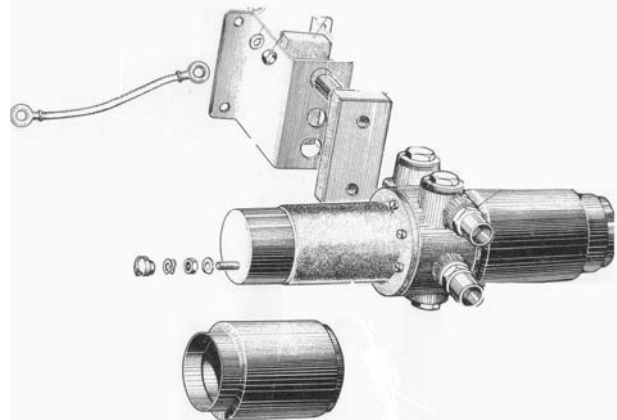

This picture is pinched from the beautifully illustrated Post-War parts manual for a Silver Dawn. Until the advent of the rotary pump on the Silver Spirit the SU pumps varied little. This one is conspicuous by having flat end caps since the idea of putting a capacitor across the points had not occurred to the Factory at this stage. Note also the rubber gaiters which proved more of a hinderance than a help. They were designed to provide some protection to the cap but more importantly stop moisture getting into the switching mechanism through the gap between the cap and the body of the pump. In practice the gaiter often filled up with water and ensured that the water DID get into the switching mechanism. The solution as we know was to use insulation tape which is used to this day.

trendy suburb Manuka. The car was actually a basket case having had a major clout in the right hand fender, losing its under-wing air conditioning in the process. The car had been to the moon and

## General Arrangement of early twin SU pumps

Reintroduced 1995  
**AUA 11** Flat cap  
**AUA 161** Stepped cap

**Pump Rebuild Kits (with full instructions)**  
 Contain two of each circled item  
 LP: **EPK 905** (1995 Production Pumps EPK 905A)  
 HP: **EPK 900** (Short Coil)

1	Pump Body	AUA 4080
2	Diaphragm Assy pre '85 (LP) - after '85 (LP) (see note) Diaphragm (HP)	AUB 6098 AUB 6082 AUB 6097
3	Impact Washer	AUB 582
4	Armature Spring (LP) Armature Spring (HP)	AUA 1449 AUB 759
5	Coil Housing (see note)	AUB 6074
6	Housing Screw 2 BA	AUA 4083
7	Centering Plates (5)	BZX 1043
8	Earth Connector	AUA 692
9	Earth Screw (4BA - H) (see note) Earth Screw (2BA - L)	AUA 699 AUA 4850
10	Spring Washer	AUA 585
11	Terminal Tag 5 BA	AUA 1455
12	Terminal Tag 2 BA	AUA 1456
13	Earth Tag 2 BA	AUA 1065
14	Rocker Pivot Pin	AUA 1435
15	Rocker Mechanism Double Point Rocker Assembly and Contact Blade together	AUB 6107 AUB 6106
16	Pedestal	AUB 6034
17	Terminal Stud	AUA 1468
18	Spring Washer	AUA 1863
19	Lead Washer	AUA 1662
20	Terminal Nut	AUA 1661
21	End Cover Seal Washer	AUB 609
22	Contact Blade	AUA 6036
23	Washer 5 BA	AUA 566
24	Contact Blade Screw 5 BA	AUA 565
25	Spring Washer 2 BA	AUA 1863
26	Screw Pedestal 2 BA	AUA 1459
27	Shakeproof Washer 2 BA	WF702105
28	Lucar Connector	AUA 692
29	Nut 2 BA	AUA 878
30	Terminal Knob	AUA 869
31	Diaphragm Gasket	AUB 809
32	Filter	AUA 1484
33	End Cover - Flat Top End Cover - Stepped Top Condenser	AUA 1486 12V AUA 5078 12V AUB 6179
35	Inlet Valve	AUA 839
36	Outlet Valve	AUA 839
37	Sealing Band	PVC TAPE
38	Plug	AUA 1490
39	Fibre Washer	ABF 189
40	Spring Clip	AUA 840
41	Outlet Valve Cage	AUA 1416
42	Fibre Washer (Thin)	AUA 1479
43	Inlet and Outlet Unions	AUB 655B
44	Fibre Washer	AUA 1405
45	Washer	AUA 1442
46	Filter Plug	AUA 1421

Note Coil housing up to Sept '85 = AUB 6074; After Sept '85 = AUB 6080. Identifiable by Earth Screw (Pre-'85 = 2BA, Post-'85 = 4BA)

The parts depicted on this page are those most commonly used and are not all applicable to every model. Some parts may only be available in a kit and not separately. See page 198 for pump diaphragm identification.

back mileage-wise and to reduce the oil consumption to below the petrol consumption I did an in-situ fitting of propriety valve stem seals using compressed air and an improvised spring compressor. Anyway..... there we were poncing through Manuka and the rotten thing failed to proceed. Everybody out and pushed to the side of the road – dignity to the wind – under I went and sure enough the pumps had decided that enough was enough. I found some stout cord and an old gardening shoe in the boot and some insulating tape. I taped the toe of the shoe to one body of the pump and the end

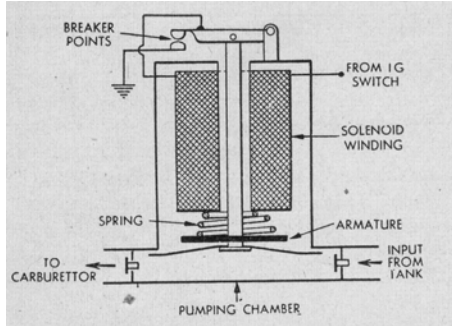

A diagrammatic sketch of the SU pump function. It will be seen that the only time the pump is drawing current is on the suction stroke so if the points burn out prematurely the pump is having trouble getting the fuel into it. The most likely cause is a blocked primary filter or more deviously a blocked petrol tank breather, otherwise a shrunk and therefore very tight diaphragm can place an unreasonable load on the circuit. A related problem is that the solenoid by virtue of the heavy and often continuous current being drawn, eventually overheats and the internal wiring breaks down.

of the cord around the heel. The cord ascended to the right rear window and was manned by one of my passengers. The radio was turned on and tuned off-station and the volume turned up. Suppressors notwithstanding, everytime the pump cycled a very audible click was heard over the radio. A short training session for the right rear passenger who was able to sense an unusually long silence and would give several vicious tugs on the cord. This had the shoe bashing the pump, thereby waking up the points and a few more cycles would keep the beastee rolling. And so we arrived home, slammed the door went inside and consumed some quietening spirits.

Being a lazy bloke I am now going to paste in an article I wrote for another journal which some of you may have read but most will not.

Despite all these unflattering words the beauty of these units are that if the driver pauses for a moment after turning the ignition on, the pumps will ensure that the carburetters are fully primed to start. So successful were these pumps that they were used on most English cars including Rolls-Royce up to the Shadow II.

Rolls-Royce among other high performance cars used two units pumping into a common chamber. This not only ensured that the engine never went short of fuel but provided a back up if one pump failed. The picture to the right is a common application and self explanatory. There are three area likely to fail, contact breaker points, the magnet assembly and the diaphragm. The most likely problem are the points which can burn out. More likely through age or strange additives in the petrol the diaphragm swells or shrinks and stops the throw-over mechanism from throwing over. This is simply fixed by undoing the screws holding the magnet assembly to the lower body and unscrewing the diaphragm a hole at a time until the points do throw-over then undoing the diaphragm a further two thirds of a turn. A tight diaphragm is usually signalled by the pumps slowing down since the magnet assembly has to work hard to pull against a tight diaphragm.

Rolls-Royce among other high performance cars used two

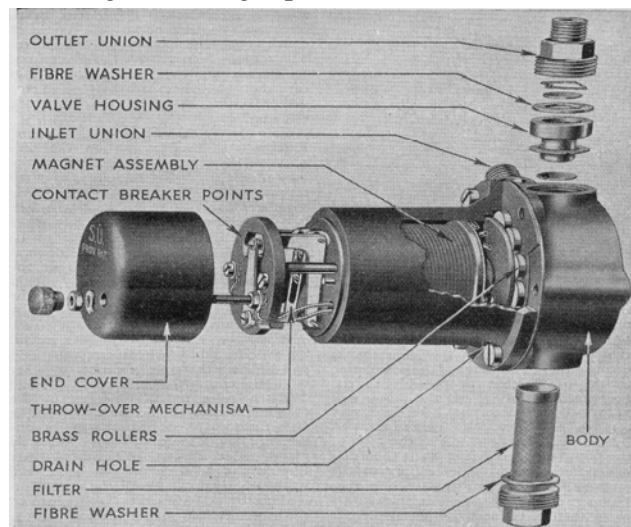

A detailed and labelled view of the pump in a single unit set-up. Again note the absence of a condenser and the use of single points. The brass rollers centralising the diaphragm which were dinky little bits were quickly replaced with a plastic form which worked perfectly well.

All this is covered in detail in the various workshop manuals but the short message is, at least once a year disconnect the pipes and run the pumps separately by disconnecting wires and note that they are clicking along at a nice rate. Overhauling them is quite simple. One last thought, all Rolls-Royce cars place their pumps lower than the fuel tank so rather than syphon the contents onto the garage floor, disconnect the pipe emerging from the tank before undoing lines lower down!

## **GET THE DIARY OUT!**

### **SYDNEY**

#### **Self Help Day – March 16th at 0930.**

Once again Phil Sproston has offered his facilities which are at

#### **Unit 1 (lower level) 17 King Road Hornsby (Phone 9939 6843).**

This is a wheels off day to prepare cars for a country trip north. There will be limited equipment available, so if you can bring your jack, stands and tools, this will help. Lunch is self catering. Coffee and tea will be supplied.

For members who were not at the November day the directions coming from the South is turn right at Westfields (opposite the station) from George Street into Burdett Street, at second roundabout, left into Sherbrook Street, at next roundabout take second exit into King Road – Number 17 is the first commercial building on your left about 500 meters from the roundabout- take second drive – DOWN- **Beware of deep dip (Air dam demolisher type) at street gutter.**

From the North turn left from Pacific Highway into Bridge Road and continue down the hill and take the second exit of the double roundabout into King Road then as above.

Also see Praeclarvm for details of the Silver Shadow, Bentley T and derivatives Register day on May 3rd at Coff's Harbour

The post-Rally NSW Self Help Day is planned for June 29<sup>th</sup>.

### **CANBERRA**

#### **Engine Bay Clean Day Sunday 3 February 2002**

Meet at the Southern Cross Club 8.30AM for a quick run to Michalago returning to the Holt Auto Port.

**Tasks:** General inspection, engine abluting, oil leaks, and abluting the body particularly the drain holes.

### **WHEELS 2002 Sunday 10 February 2002**

9.00AM at Exhibition Park enter through the gate at the side of the Shell Service Station at the top of Northbourne Avenue. This is a display of all interesting cars which attracts a large public audience and raises considerable funds for a nominated charity. We hope to put on an interesting display with the theme on maintenance. We will have a marquee which will be well anchored, displays and barbecue facilities as well as loads of ice and things to chill. A site has been allocated.

The Silver Dawn, the Silver Cloud and Silver Cloud II and derivative Bentleys mounted their pumps by bolting the common central pumping chamber to the chassis, insulated of course by suitable rubber blocks. The Silver Cloud III switched to a separate mounting plate and encircling clamps lined with rubber that held the pump in a flexible situation and simplified connection by using flexible lines to and from the inlet and outlet valves.

The Silver Shadow used a simpler and lighter pair of clamps to hold the pump in a similar fashion and continued with the flexible lines. The pumps however remained much the same, fiddling with suppressors and breathers for the end cap and dampening chambers on the central body.

'SU' Like many expressions in our language the origin is forgotten. 'SU' originally stood for Skinner Union a firm that tanned hides. They invented a carburettor that used a leather diaphragm which eventually developed into the SU carburetor that we know today

To do a quick test on cars up to and including the Silver Cloud II, simply hold down the snifter button either of the carburettor float chambers and listen for that steady beating pump (assuming the ignition is on.)

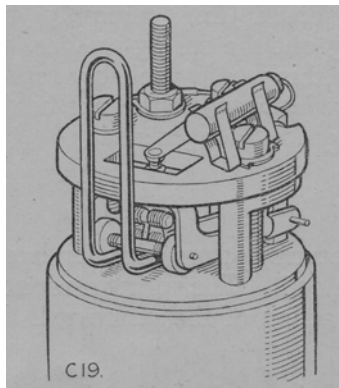

One method of stretching the diaphragm prior to screwing down the pump body is to make up a wedge to lift the central threaded bar into which the diaphragm shaft screws. This allows the armature to be held tightly against the solenoid face while you tighten the screws. I prefer to energise the solenoid by putting a potential across the main terminal screw and the mounting screw of the fixed points while the pump body and diaphragm are loose on the body of the pump. The fixing screws can then be tightened. This method ensures that the diaphragm shaft is central in the magnet and avoids problems with binding point mechanisms etc.

## (MORE YET TO COME ON PUMPS)

### HAIR SHIRT DONNING

Guy Cox's eagle eye spotted a typo that could be a bit damaging if it were not picked up. Guy's email follows.

' There is an error in the December Tee One Topics which could be potentially disastrous for owners seeking replacement hydraulic fluid in an emergency. On page 96 you say "Citroen apparently specified the fluid (RR 363) for their cars produced from 1955 to 1986". This is quite wrong.

Citroen cars require LHS2 fluid (which appears to be much the same as RR 363 though it is a different colour) for their cars from 1955 to 1965. Around 1966 (I don't have the exact date to hand) they changed to mineral fluid - LHM - as used in R-R cars from ~1980). In other words, Citroen had changed to a mineral based fluid almost as soon as R-R had started with the synthetic sort. So LHS2 from your Citroen dealer will do in an emergency for your Shadow I, but LHM as used in Citroens from ~1966 will only be suitable for 1980 or later Rolls-Royce and Bentley cars. Incidentally, LHS2 was not in fact the original fluid for the DS Citroen - that was a vegetable based fluid like the brake fluids of the period - LHS2 was a wholly synthetic replacement designed to be much more durable, less hygroscopic, etc. On its introduction it was recommended as a replacement for the earlier fluid in all models. Once in rural Spain I was forced to mix the older fluid with the LHS2 in my car (an ID19) after a leak - it didn't seem to cause any problems.

Guy Cox

## A Matter of Magnitude and some Misgiving

*(You will realise that this was written for the last issue but it was received when the postman had already left)*

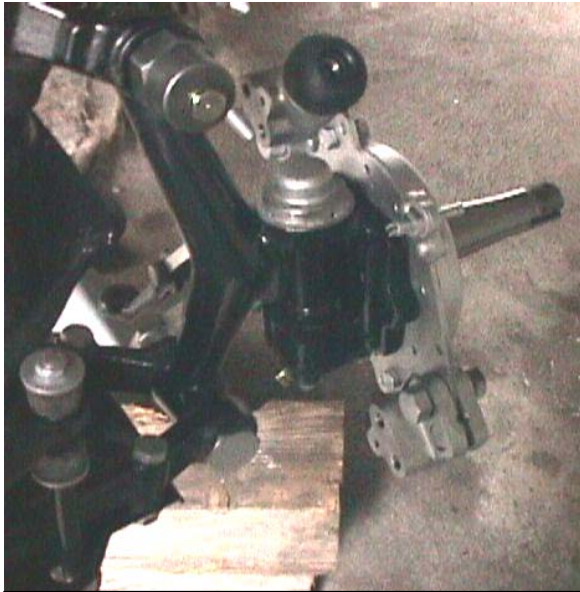

The last of the drum brakes built by the Factory. Unlike models previous to the S series and most other cars the brake shoes were mounted on a very stout plate which was bolted to the stub axle. The backing plate merely kept the dirt out.

There has of late been a spate of denials of responsibility in the pages of this august Journal. Let me join the rush. I very much fear I may have led readers of Tee One Topics astray on the matter of the suitability of eucalypt blocks as car stands. In the seventh issue I suggested you would find 300mm long blocks eminently suitable. Experience has proved otherwise. Perhaps I might relate the circumstances. A certain Silver Shadow (for ease of reference referred to hereafter as SRH) has been undergoing an amount of work to her nether regions. To facilitate this she was raised on blocks as previously related. Certain parts were removed, and in achieving this both George Shores and myself had occasion to work beneath the said SRH. The work was tiresome but achievable. The parts were removed, taken to the residence of Mr B.B.Coburn (for ease of reference referred to hereafter as Bill) where, as related somewhat gleefully in full embarrassing detail by the said Bill, paying little regard to SRH's sensitivities, they were refurbished. They were then returned to the place where SRH lay, so to speak, and we

embarked upon refitting them, supervised as always by Bill's delightful dog Lara, who as many of you

would be aware continuously snuffles and grunts in a charmingly characteristic fashion. At one stage I had recourse to slide supine beneath the car, and identifying something that I thought would facilitate the task upon which Bill was embarked, suggested that he should join me. Then followed those aforementioned characteristic snuffles and grunts. No Lara - keep out of the way! produced only an increase in snuffling and grunting. A slight turn of the head then revealed the intelligence that it was not Lara but Lara's dad - and he was very close to being stuck!

He wisely desisted in time, much to my relief, as a stuck Bill would have been utterly beyond my puny strength to



And here is the whole setup, normally inside the drum. Since the backing plate can't be used to steady the shoes special steady posts are used which can be seen in the centre of the shoe webs. They in turn engage the shoe through a friction device which prevents them from moving away from the drum surface any distance. Occasionally these seize through lack of attention (the friction discs must never be lubricated) and the brake shoes stay on emitting alarming great clouds of smoke.

extricate. So please disregard my earlier advice - 300 mm blocks are not adequate, regardless of their stability and impressive longitudinal compressability factor.

I have since snuck surreptitiously into Super Cheap Auto and invested in four 1.2 tonne rated capacity car-stands at \$29.95 the pair, which did much for my peace of mind. ( I had had nightmares of listening to the sighs of a slowly staving and deflating Bill as his girth reduced to a stage where he could slide back out - it was very distressing. You have only to refer to the photograph published in the last Topics, where Bill even described himself as  $\text{\textcircled{E}rotund}^1$ , to realise that the process led to quite a prolonged nightmare). But then I had another awful thought. What if he'd had a heart-attack? What if even now he had a heart-attack? Where would that leave me, still needing his expertise to complete the various tasks we are embarked upon? And where would it leave the Tee One Movement, if I can describe it as such, without young Bill, with his wealth of technical knowledge, enthusiasm, and willingness to share? A sobering thought indeed. But being wise in the ways of rejuvenation, and non-standard methods of resuscitation, he assures me that Glenfiddich is a sure antidote to any incipient heart ailment. A gem of advice which I leave you for Christmas and the New Year, to do with it what you wish but all responsibility denied.

Bill Fleming

## Synchronising Dual Pumps

This is a chestnut that pops up from time to time. Allegedly the pumps are coordinated so that they both pump at the same instant. To my mind this would be almost impossible and quite unnecessary. Anybody know something on this topic?

## Overall

I have just spent some 8 hours mucking around with the dual pumps on the S2 and now they run beautifully but I can understand why 'service stations' advise fitting new units rather than recondition the old.

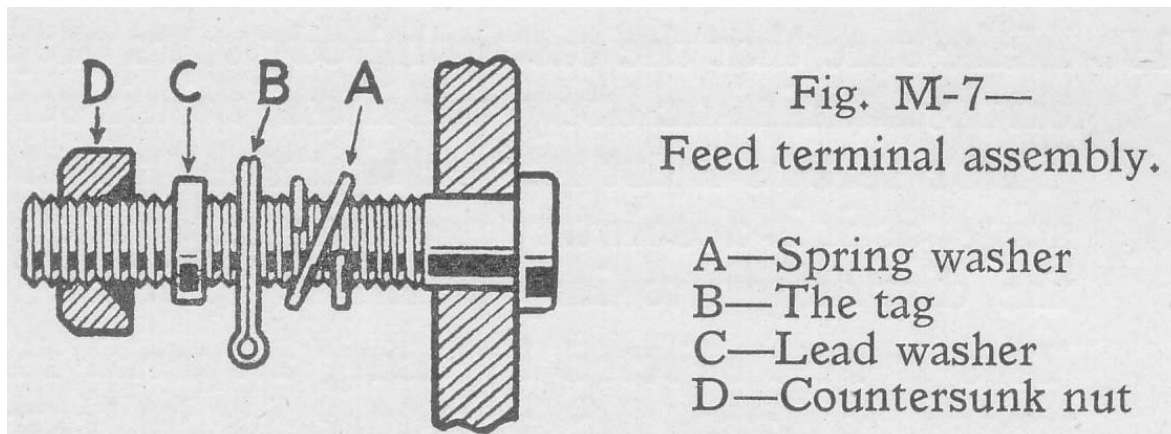

A few interesting points here, Note the concave nut (D) and the lead washer (C) 'B' is the terminal tag from the solenoid and tightening the nut squashes the lead washer onto it ensuring a good contact. Therefore whenever this terminal is disturbed the lead washer must be replaced. They are readily available at about 60c each. Lastly (A) is a Thackeray washer, a term almost lost to posterity. They are effectively double spring washers and are used where joints are loosened and tightened frequently and where the tightening torque is not great.



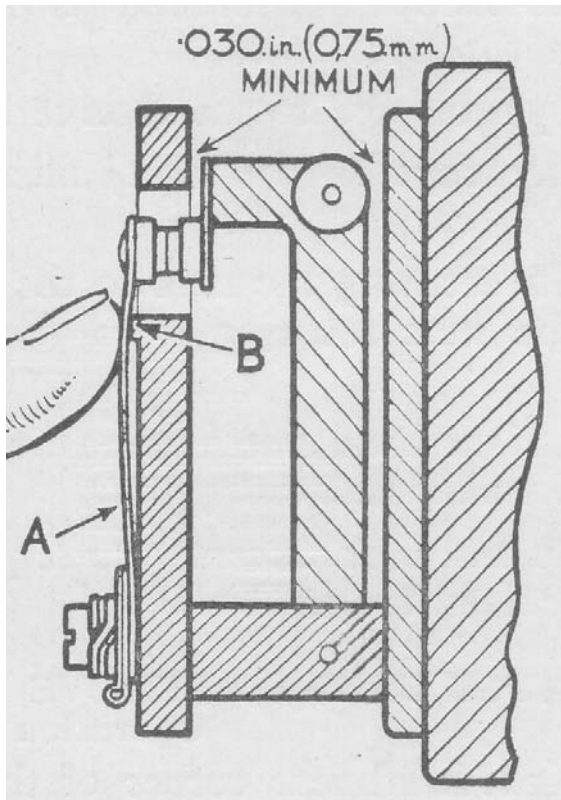

This is the Achilles Heel of the Pump, the points, shown here in side elevation. The points having been assembled in the pedestal, noting that the latter has to be loose to get them under the ledge, ensure that that when the pivot pin is inserted (and no there is no easy way to do that) that the whole assembly is free to move and that when the fixed point is screwed down the points (both surfaces) meet evenly – (I have come across new bent points). If they are tight the pump will be sluggish, if loose the points will wander. Note that the pivot pin is case hardened – no using a bit of wire or an old drill!! The fixed contact or blade is fitted under the terminals against the bakelite pedestle and should rest on the ledge (B) when the points are apart. Gently pressing the blade onto the ledge but avoiding bending the projecting section , measure the clearances shown in this diagram. It is rare for an adjustment to be necessary but if so the end of the blade can be lightly set to achieve the desired clearance.

## The Condenser

All but the earliest pumps have a condenser fitted across the points. Should you open a pump and find the pumps badly burnt with significant deposits around them, best you replace the condensers to be sure they are not going to cause further problems. The only practical test we can do is to ensure that there is no continuity between their terminal and the case.

## Armature Centering

Early units had beautifully made brass rollers to hold the armature and diaphragm centrally under the magnet. Later, various plastic devices did the same job and were much easier to fit.

---

## SHOPPING AROUND

### SHADOW DISTRIBUTOR CAPS

A couple of meetings ago David Gore advised that the distributor cap for a Shadow 1 was the same as the 1972 Valliant V8. I found that there are three different distributors fitted to 1972 Valliants. The one for our the Silver Shadow is the Bosch GL665 Distributor Cap, which also fits the 1972 Range Rover & Dodge trucks. They are available in Black. I purchased mine from Robbo's Spares, Canterbury Rd, Campsie. It cost about \$35. The rotor is also available, Bosch Part number GL854.

Alan White

## LEATHER

From the self help meeting of the 24th November, I was very impressed by the discussion on leather restoration. I followed the advice and my leather now looks new again. I obtained my lacquer, sealer and solvent from "Masters of Leather", Unit 19/ 167 Bonds Rd, Riverwood. Ph 02 9153 7555. With excellent guidance from Wayne even aftersales.

Alan White

## DISTRIBUTOR MODULES

Had a Shadow stranded in an auto electrician's shop in Condor (a suburb of Canberra). Seems there was no spark emerging and all signs pointed to a complete failure of the electronic internals. Further complications were that the factory replacements appear to be less than satisfactory and 'those that know' suggested local solutions. Found that a popular choice is the unit supplied by Piranha a name normally (in my mind at least) associated with burglar alarms. Anyway these units are apparently excellent and trouble free. They are available by Part Number T 05 B from British Auto Parts, 39 Moxon Road Punchbowl NSW Phone 02 97072466.

## Rubber Mouldings

Grippy Rubber Products is apparently well known to our Sydney people but not to the villagers in the ACT. I have already bought boot sealing rubbers as you are aware for the Shadow and firewall rubbers (1.5M per car) which appear eminently suitable. I asked the lovely lady there to send me samples and part numbers of anything she had in the RR department. The following is a reference. Don't rush in and order miles of rubber without being sure of what you are getting, she will send you a sample. It would also be advisable that you check the price and availability of the genuine product. Firewall rubber incidentally was changed at least three times during production to my knowledge. That which Grippy are offering is but one solution. They can be contacted at: -

21 Brodie Street RYDALMERE 2116 Phone 02 9898 9688

Grippy Part Number	Car model	Description
GG 290	All 'S' and Cloud series	Rear window rubber
GG271	Postwar Silver Dawn, Bentley Mk VI & 'R' Type	¼ vent window
GPR 109	Ditto	Door seal
GG289	All 'S' and Cloud series	Windscreen rubber
GG175	All Post-War cars	Over rider beading
GG 206	Postwar Silver Dawn, Bentley Mk VI & 'R' Type	Sill strip moulding
GG255	Silver Shadow and Silver Shadow II and derivatives	Boot seal 4.5 metres
GG 249	Silver Shadow and Silver Shadow II and derivatives	Firewall seal also known as bonnet seal (1.5 metres)
GG250	Silver Shadow and Silver Shadow II and derivatives	Rear window rubber
GG249	Silver Shadow and Silver Shadow II and derivatives	Door seal
GP18	Corniche	Firewall seal also known as bonnet seal (1.5 metres)



## Rocker Cover Gaskets

Those old enough to remember the very first Holdens with the grey motor will remember the challenge presented by their engineers in trying to prevent leaks from the rocker cover and the head. I remember viewing my first Rolls-Royce engine – a Mk VI Bentley and being amazed that the valve mechanism was actually recessed into the head and that there was an inch or so of metal holding the oil in before the cork gasket had to take the load. This innovation continued to this day but then we were propelled into that vulgar V 8 and the whole engine as far as the valve mechanism was tilted on its side. Once again there was the problem of leaks on the lower side of the cover. Many owners do not realise this as the only way to see the mess is to get right under the engine and look up! The solution however is now at hand in the form of a moulded neoprene gasket that fits and seals beautifully. If you are still running on composition gaskets change over in the interests of cleanliness.

---

**This newsletter is put together by Bill Coburn as his personal contribution to the repair and maintenance of Rolls-Royce and Bentley Motor cars. Readers are cautioned to make their own decisions about the accuracy or otherwise of the contents. Every effort is made to disseminate what appears to be worthwhile information in the hope that the lonely owner will have some idea of where to start!**

**Contributions are earnestly requested in any form whatsoever but preferably in English!! My access points are Phone:- 02 62864903 FAX:- 02 62864910 email:- [cavacharles@bigpond.com](mailto:cavacharles@bigpond.com)  
Mail:- Post Office Box 8 MAWSON 2607**

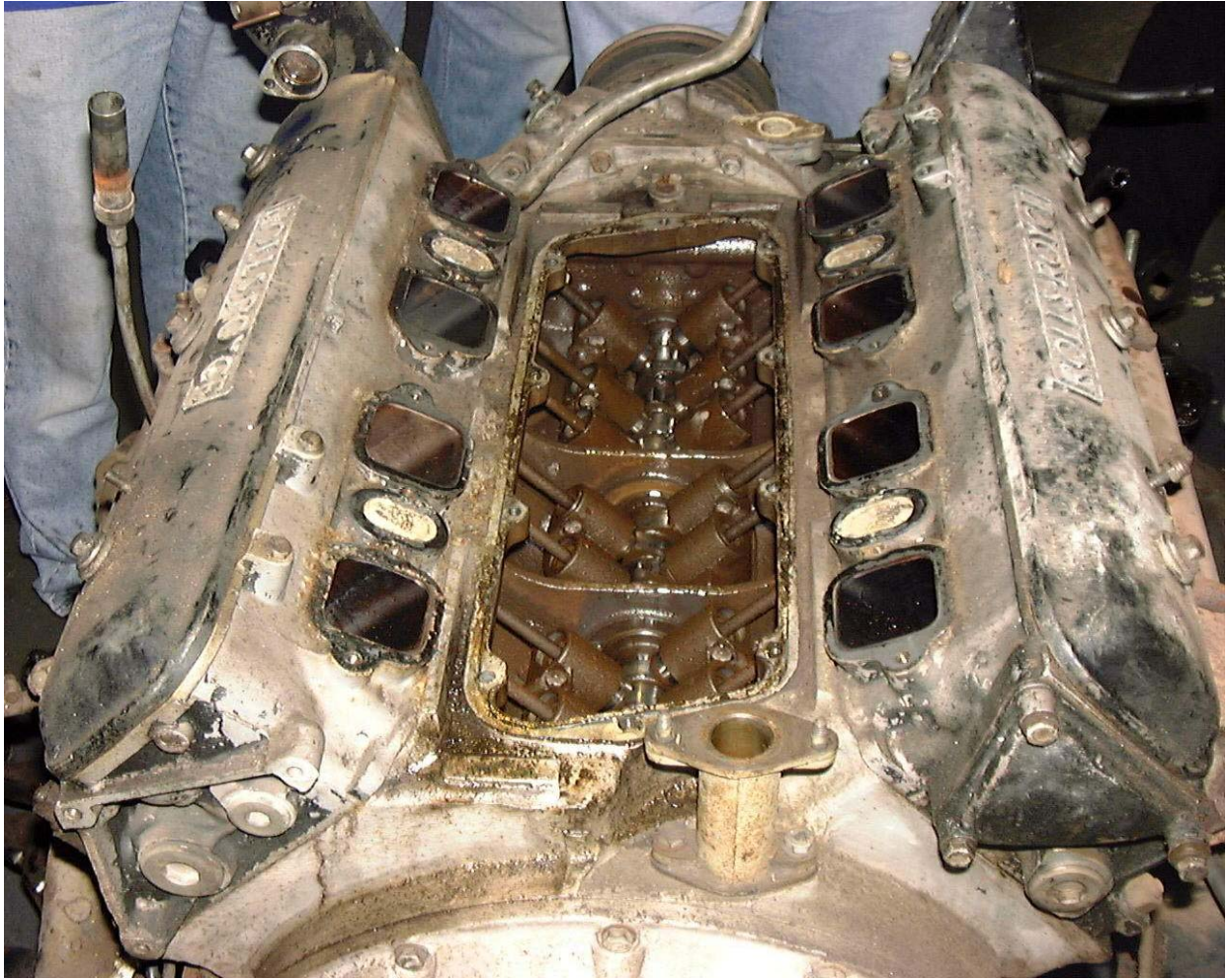

## And Talking of Gaskets

The correct method of sealing this inner sanctum is with a fine thread of silk. Apparently the last invader of this engine thought some goo would be a better idea or maybe his Mum didn't sew!



And here we have the rear of the two hydraulic pumps that often clatter away hidden among the tentacles of the inlet manifolds. To remove these pumps requires a serrated tube spanner one of which I had. Now I don't have it. Has anyone got one I can copy? The serration on the pump can just be seen near its base and access is simple once you remove the pipe, the circlip and the cover!

# Nostalgia



Many years ago an intrepid member of the RROC in New South Wales and a similarly intrepid member in Western Australia, pooled their intrepidity and decided to make a record breaking trip from Sydney to Perth in a 1914 Silver Ghost chassis number 6TB which is still in the Club. As a support vehicle the Perth member stripped the body off WGC 47 and had the above fitted. The car then drove to Sydney to accompany the Ghost across the continent. Meanwhile the Ghost was carefully prepared and at one stage tested in the area of the owner's rather desirable suburb. As I recall a speed test on a suitable road resulted in a radar check by the police who pulled the car over and announced that the recorded speed was 72 miles per hour. The owner protested that the car couldn't do more than 60 mph so the police sent him back for another run and this time it clocked in at 78 mph! Apparently the law was so impressed with the whole exercise that they sent him on his way.

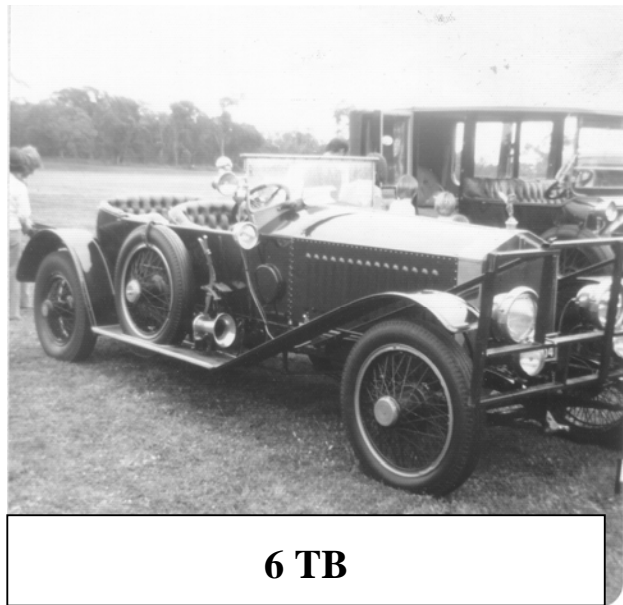

The car crossed the continent in 46 hours and 57 minutes averaging 55.76 mph and got over 12 miles per gallon. Well they don't build cars like that no more do they! The only mishap they had was a failed battery which had been brand new when they set out. And we don't have such romance in the movement any more it seems.

## Postwar Engine Lurching

Obsessed as they were with insulating passengers from the vibrations of the engine, the factory used an idea from Plymouth called 'Floating Power'. The line drawn through the engine in the diagram is actually the axis of the assembly around which the engine oscillates. Sudden acceleration however would probably see the engine rotate, or try to, in the engine compartment. You will note that Plymouth used a reaction spring behind the clutch, the Factory used a torque arm across the back of the gearbox jammed between a couple of rubber buffers.

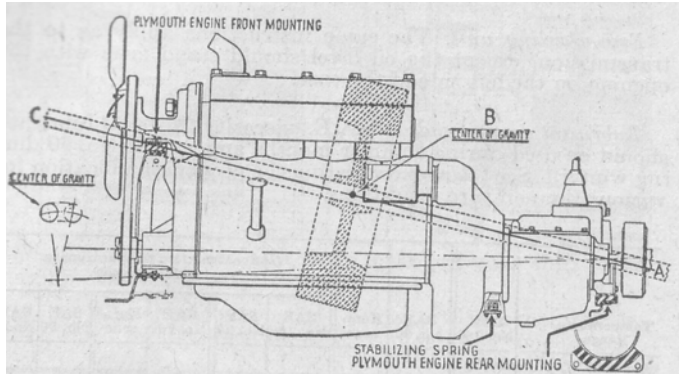

This approach was used on all cars until the advent of the 'S' series which used the fairly conventional two lower engine mounts forward and a very dinky little rubber mount at the rear of the gearbox. The V 8 engine reversed that scheme and went for one mount forward and two behind with the gearbox hanging out in limbo!

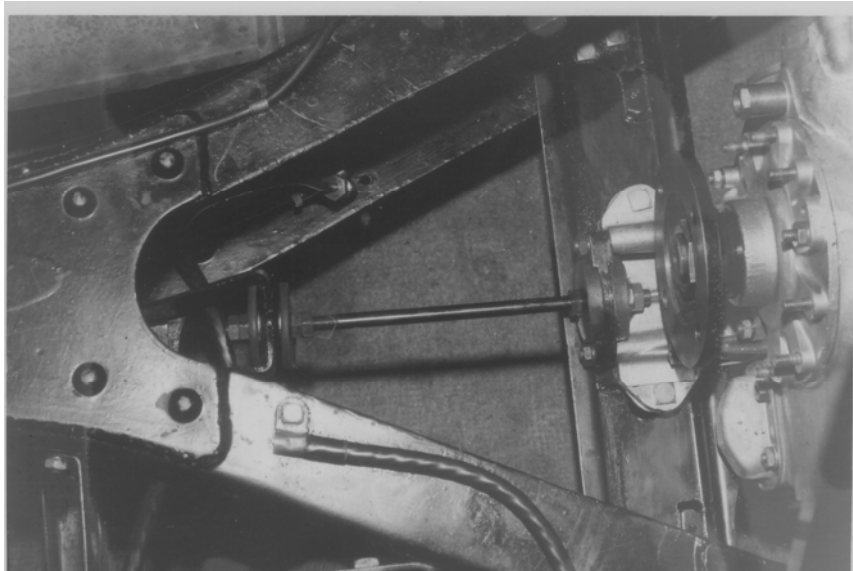

An interesting dividend followed Plymouth's efforts here as they are credited with developing the multilayer engine mount we use today and particularly the technique of bonding very dense rubber to metal.

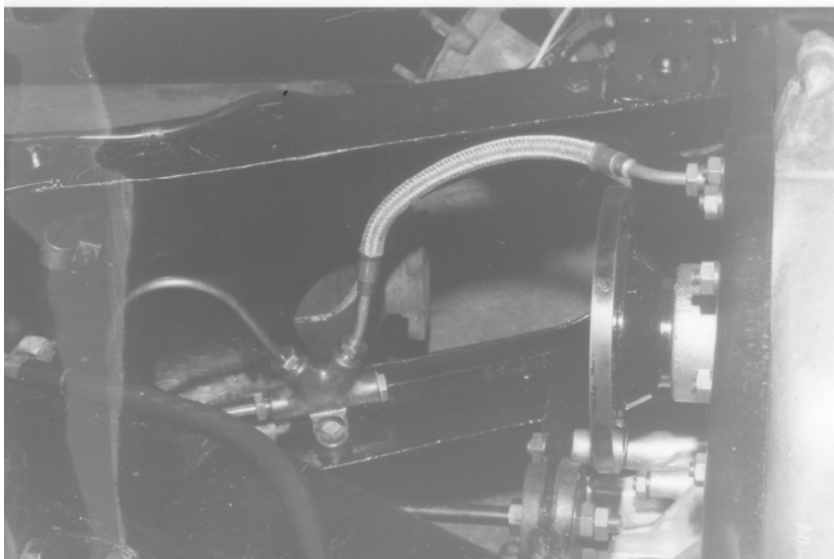

But we are not out of the woods with the pre S series cars. Given the height of the front engine mount and the flexible saddle the thing sat on, there was a fairly good likelihood of the engine fan eating the radiator core in the event of a sudden stop! The solution was a rubber insulated tie rod at the back of the gear box. These have been known to break or the rubbers rot to destruction producing some extraordinary noises. If fitted with a manual gearbox a rotten rear engine mount can completely immobilise the car through the gearchange mechanism disengaging itself from the selectors.

And lastly while discussing rear ends, rear suspension dampers were controlled prior to the S series by a bellows mounted control valve that in turn was moved by oil pressure from the gear box. To get the gearbox oil to the dampers a flexible hose was needed from the gearbox to the chassis and this is one area that should be monitored carefully. The spectre of a ruptured hose pumping all the oil out of a manual gearbox and the latter subsequently failing is a contemplation I do not want to experience.



**THE  
SECRET OF SUCCESSFUL  
RUNNING**

Before a Bentley car is sold, it is very carefully tested and adjusted by experts. It will run best if no attempt is made to interfere unnecessarily with adjustments.

An owner would do well to instruct his driver as follows:-

Lubricate effectively, in strict accordance with the advice given in this book, and do not neglect *any* part.

Use only those oils which are recommended by Bentley Motors (1931) Ltd., who have made prolonged and searching tests of oils. Considerable harm and expense may result from the use of unsuitable oils.

Inspect all parts regularly, but take care not to alter any adjustments unless really necessary.

*(Bentley Mark VI Handbook circa 1950)*

**So there you have it!!!**

---

If undeliverable, please return to  
Post Office Box 8 MAWSON 2607  
Australian Capital Territory  
**AUSTRALIA**

**POSTAGE  
PAID  
AUSTRALIA**