

# TEE-ONE TOPICS

Number 56 September, 2006

---

---

## THE HYDRA

It is strange that Hollywood hasn't recruited the Hydra. It is ready made with plenty of backup in publicity and to students of mythology it is quite a credible monster. As all of you would know the Hydra lived in swamps in ancient Greece. It was apparently quite terrifying having the body of a serpent and several heads – the number varying from 5 to 100 although nine seems to be the standard. Its breath could exterminate a man or beast with one puff and one other drawback was that cutting off a head wasn't much help as it would immediately grow another one apparently the stem cell debate was sorted out in those days!. The hero Heracles eventually dispatched the beast, as to how – go do your own research.

Well you are wondering why you are being subjected to this diversion? Well I feel like a Hydra although my disposition is quite friendly and I do pay attention to my oral hygiene. These pages were originally a form of diary to make some record of the findings and shared experiences of a group of enthusiasts that liked to pull their cars to pieces, maintain them, fix them or simply try to understand how they worked. This I should add was in the face of a small coterie of owners who observed our practices as somewhat unsavory, hazardous, inappropriate and no more than inexpert tinkering. Surprisingly the tinkering not only continued but grew noticeably in New South Wales and Victoria where organized groups still get together for mechanical enjoyment!



And now these pages have as our homegrown ones so head of my Hydra analogy. the excellent forums around the including our own excellent Separately but in the middle of a couple of stalwarts is

various documents relating to Rolls-Royce and Bentley cars. These are available to the world on the Federal site <http://www.rroc.org.au/> and thence to the forum. It matters not whether you are a member of a club, an owner, an enthusiast or just a curious sticky beak, you can download whatever you wish. Hopefully, this may just facilitate a few intrepid souls rescuing doomed drooping Ladies from the wrecker's hammer and getting them back on their wheels thereby preserving them for future generations. Because there simply aren't any more. A seriously damaged or neglected Rolls-Royce of Bentley is usually not an economical proposition to restore. Who cares? If you can find the money and the time and have the love of the cars in your heart, do it yourself. We are here to help you. It matters not whether the car may have the wrong bumpers or been finished in cans of spray enamel or upholstered in calico, have 'widies' 'wobblers' four inch exhausts or a gold plated grille. If the basic bits are still there and intact it is a Rolls-Royce or Bentley and deserving of your attention. So for those readers who haven't taken the plunge get out there and start rescuing!!

## HOW IS YOUR BACK?



In accordance with Murphy's law the worst kept Spur in the country set off for Mudgee from Canberra recently to attend the annual S.M.A.R.T Group get together – a round trip of about 1000K. The day before departure I noticed that there appeared to be more bumps in the road than usual. Ever ready to confront the local government, I hesitated and went around to the rear of the car and knelt on the back bumper bar. It descended about two inches then stopped very firmly. As you know these cars are beautifully sprung on nitrogen but when the latter dissipates which it will with time, the suspension consists of a solid column of oil in the rear dampers and all you have to soften the ride are the tyres and the rubber packing pieces inserted through the system. The



nitrogen of course is trapped or should be in the 'gas springs' screwed into the top of the dampers. If you pull the lining of the boot out you will find them nestled away in the corners above the rear wheel arches.

I contemplated a 'quick' change before departure but fortunately couldn't since although I had boasted that it was only 'a ten minute' job, I knew in my heart it would take some hours. The gas springs look exactly like the brake accumulators but are larger with a different nitrogen pressure charge. The manual will tell you that you should remove the adapter

on top of the rear dampers into which the spheres screw but I have seldom found this to be necessary.

The spheres simply unscrew from the adapter. To do this you will need a chain wrench, a readily available tool. The chain is wrapped around the sphere and you lay your bulk into the handle. They are often very tight and resort to extending the handle is a good idea to save the biceps. If you still

find them frighteningly tight, best you do remove the adapter and sphere, put the former in a vice and seriously lay about the sphere. DO NOT as some brilliant entrepreneur recommended publicly recently, pierce the spheres with a cold chisel to gain extra leverage. They are pressure vessels and should be treated as such.

The first step however is to rid the system of hydraulic pressure. Unlike the old Shadow system, emptying the brake accumulators of pressure does not deplete the rear suspension struts or gas springs. This must be done via a bleed valve mounted on a flimsy little bracket on the inside of the under body just ahead of the wheel arch.

Hold the tapping block that the nipple screws into to avoid breaking this mount. To exhaust the



system the car will need to be standing on its wheels. Exhausting the system will let the car sink to a very low level so don't lie underneath while letting the pressure go otherwise you will probably remain there for the rest of your life! You can jack the car up and stand the rear wheels on car ramps or large blocks of wood. Post '86 cars tied both sides of the system together on the one circuit so one bleed screw will empty the lot!

Screwing the new ones back in with a new seal isn't brain taxing. They do need to be tightened up securely however. Remember when ordering

the spheres to order the 'O' rings that fit in their necks. (Apparently even the new providers of bits haven't grasped the concept of a kit here so that the sphere and the seal would come together!!!). As to time to do this job as so often happens getting to the target bit takes more time than doing the main task. Unscrewing the screws holding the boot backing board is time consuming as is removal of the right hand inner boot lining. The battery should be disconnected as you will need to dismount the battery master switch which as you can see is right in front of the right hand gas spring.

Finally bleed the system, finishing off with the rear struts and you should have recovered the great ride originally supplied with the car.

As to the Mudgee trip, we went with flat springs and boy did we know it. It does not do the car any good leaving the springs exhausted and it certainly doesn't improve the condition of your back! The combining of the two rear systems in later cars is of interest. Originally the leveling valves that control the pressure in each strut would lift or lower the respective corner of the car to keep the latter level. So when one of the early cars was tooling around a long slow bend at high speed the outer side of the car would be jacked up by the strut on that side. But when the car then had to make a hard turn in the opposite direction, the strut couldn't exhaust fast enough to level the car. The result was a fairly unstable vehicle until the system worked out what it had to do. Note that this system is always on slow leveling unlike the earlier Shadows which had instant lifts in various situations. The solution with the SZ cars was to have one leveling valve which pumped up both rear struts together. The valve was connected to the centre of the rear anti-roll bar. As the car sank the bar turned and the valve leveled.

## FILTER FLUTTERS

As the novelty of supporting the old Factory's products wears off we are going to see more and more line items in the spares department, removed. The need to keep a stock of left hand glove box support bars for a long wheelbase Bentley S3 is difficult to support and most reasonable owners

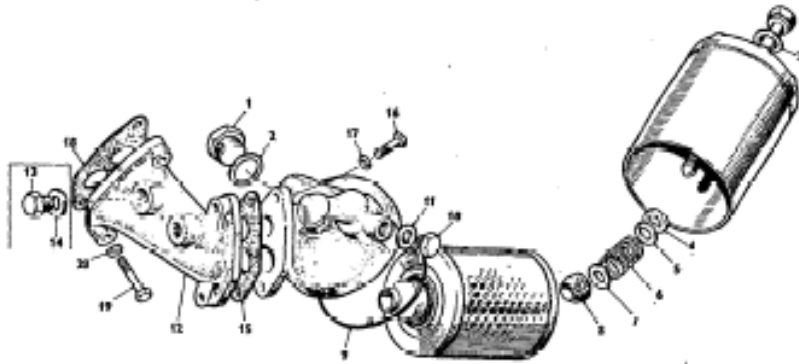

would redirect their searches to wreckers. There is also the fundamental problem of scale. A couple of years back Crewe Spares ran out of engines for the vee eight post55 cars as well as associated cylinder blocks.

This is the general layout for the Shadow I which uses the now obsolescent cartridge filter. One catch here is that the unit requires a conical cork seal (8) shoved up its bum by the spring (6). Croslands to my knowledge never supplied this seal and if you bought the seal alone from your friendly Crewe Spares man it brought the total cost of the filter change almost up to the filter replacement assembly supplied by the factory. The cork seal however would usually last for three filters and then you could fit a new Factory kit.

One of the Company's principals told me that when they approached foundries for a re-manufacture of say 30 new blocks they were virtually laughed at for asking for such a small quantity. Many bits needed for our cars also cannot be easily manufactured in this day and age regardless of how many units are required simply because things are no longer 'made that way'.

This is the setup for the Cloud II & III. The filter shown was the factories attempt at filter manufacture. The 'scroll' was actually made of thick punched metal and was covered by a felt bag. One of the earliest experiences I had with this form of filter was on a very neglected S2. When I removed the filter element all that was left was the metal scroll. The engine required complete rebuilding shortly afterwards.

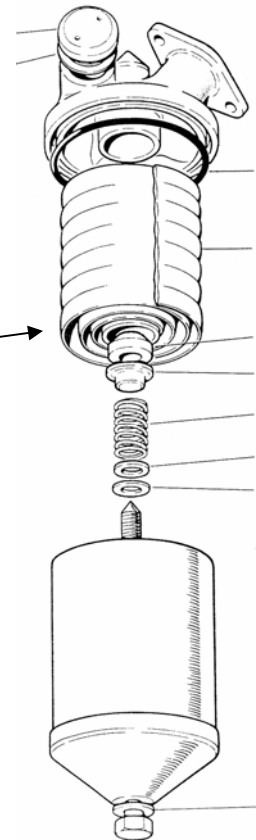
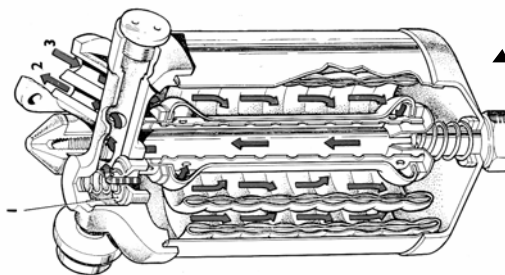

So the latest casualty is the oil filter cartridge for Clouds and Shadow 1's. It is thought the Factory has stocks of them which are readily available at their price but the external manufacturer a British company has ceased production of these units. These were quite satisfactory and half the price of the genuine items. Hope is on the horizon however as Introcar of London [www.introcar.co.uk/](http://www.introcar.co.uk/) believe they have found another supplier. It would seem however that we are on notice.

Other measures to overcome this 'crisis' include fitting the spin on pedestal used on the Shadow

II's and SZ cars so that a spin on filter can be used. The changeover is very simple as the block mount on the two engines is identical. This is by far the best solution, a small catch is that the pedestal is no longer available so it is off to the wreckers! Note that the pedestal cannot be used on the Clouds since there is not enough room between the mount and the central engine cradle.

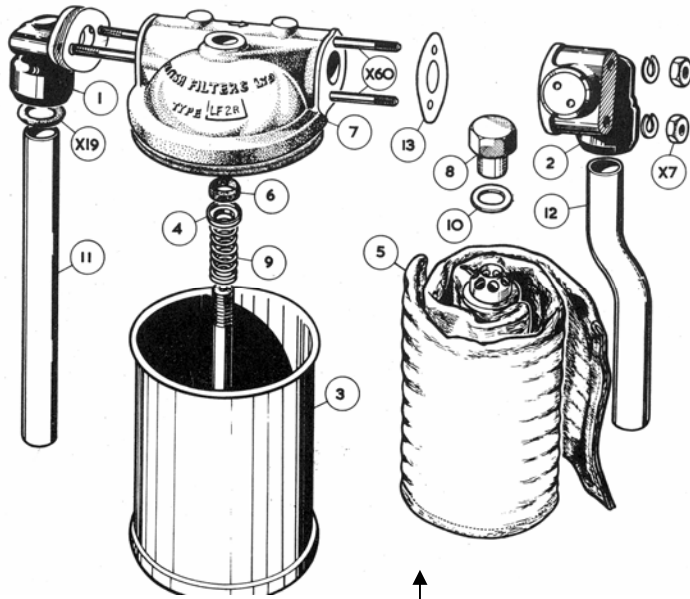

production.

The remaining solution is to have a batch of adapters made up that can be fastened to the existing filter head which will allow a spin on filter to be fitted. This is a solution adopted by many clubs that enthuse about choice cars but which are now well out of

And here we have the Cloud I setup which really followed the old dawn and Wraith. Given the length of the six cylinder engine the only place to stick the assembly was under the inlet manifold and carburetors.

Talking of layouts this was the scheme used on the post 20,000 series cars. Note that the pedestal now feeds the filter via flexible pipes. The filter mount is at somewhat a remove to the engine but this at least makes room for other bits!

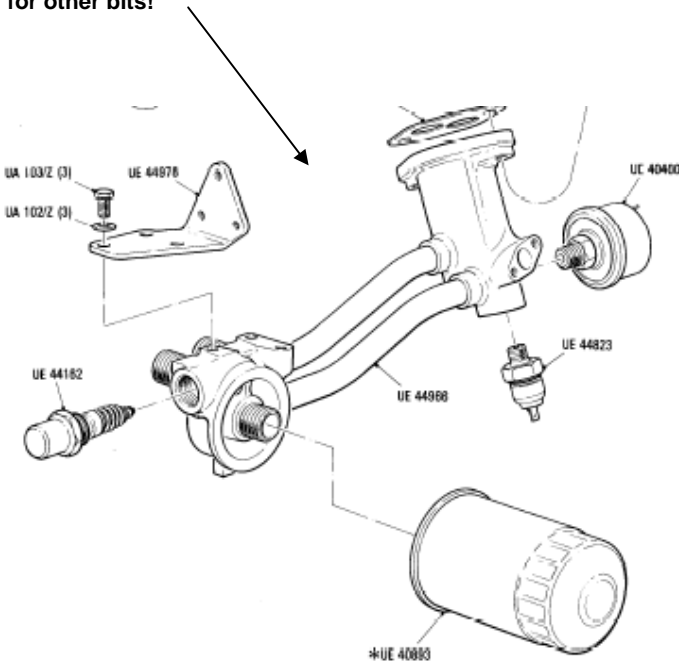

## THE RECALL THAT NEVER OCCURRED

I remember one of the directors of the old company (how's that for name dropping) remarking that they grew to being very careful with issuing service bulletins correcting perceived faults in their cars. This attitude clearly stemmed from the burgeoning practice of litigating for profit that a sizable proportion of the world's population adopted. The 'Bulletins' put out during the Mark VI era as I choose to call it certainly 'let it all hang out' which was very helpful but with the Shadow adventure, when a goodly proportion of the Factory personnel must have at least contracted chronic dyspepsia, so many problems occurred that issuing bulletins became a little impractical. The solution was to stop production which they did a number of times to sort out a batch of troubles and then start up again. In fairness the venture they undertook in getting that model on the road surely rivaled the seven labours of Hercules! But they did it and the model was more populous than all cars produced before it combined!

One 'category one' modification which was really a recall but up to then such terms were not acceptable, involved the brakes. As you know the Shadow effectively had three braking systems which meant that short of a cataclysm the driver would always have some sort of stopper under his foot! But then somebody found out that the clevis pin connecting the brake pedal lever to the whole braking mechanism could fall out leaving the car with zilch brakes! Cars were quickly collected and a retaining plate fitted. And then there was the affair of the cruise control first fitted to the Shadow. As we all know any cruise control must cut out at the slightest touch of the brake pedal, in fact it is triggered by the long used stop light switch!

Fortunately some hapless tester doing a pre-delivery run in a new car did just that and nothing happened, the thing kept controlled cruising. Not good he thought. The news prompted the Factory to recall every car fitted with the device since they all had to have a wiring change. And they actually issued their first recall. It made the world press!!



But in Canberra in the early eighties on one miserable cold Saturday afternoon I had a phone call from an owner who was stuck at one of our larger car washes. Seems he couldn't steer the car and yes the wheel would turn but the wheels wouldn't swivel. A quick trip and a slither under the car while the steering wheel was turned – the Pitman arm had broken.

**This is the 'naughty' end of the Pitman arm. The breakage occurred in the spline which allowed the pitman shaft to turn in the splined hole. The modified arm which was discreetly produced is clearly beefier. But if you want to know which arm your car has, look for the ears on the splined end which were there for dragging the thing of the splined shaft.**

Maybe you call it a steering arm or the more traditional 'pendulum lever'. Call it as you will it is the God given connection between

life and death for the car and you! The arm which is fastened to the Pitman Shaft which pokes out of the steering gearbox is designed to push through various levers and links, the wheels from side to side. If the arm breaks you may regret not having persevered with harp practice! It is so fundamental to safety that most people simply take it for granted. Somewhat shocked I called the then Sydney agents and got a very helpful response along the lines of would it be convenient to get the car onto a carrier and ship it to them and they would repair the car.

This I did first thing Monday wondering what expense I was incurring. A week later the owner received a phone call to the effect that his car was ready. It had a new pitman arm, had been fully serviced, washed and polished and was ready for collection. There was no charge. The rub was that this occurred a number of times in Australia and apparently each owner got the same treatment. The generosity was clearly aimed at preserving reputation and despite the perilous nature of the fault no recall was ever issued. In short if I had a Shadow I, I would be subjecting the Pitman arm to a professional metallurgical crack test! Meanwhile please avoid turning the wheels against curb or fighting a wheel in the channel situation which you sometimes find in large car washes!

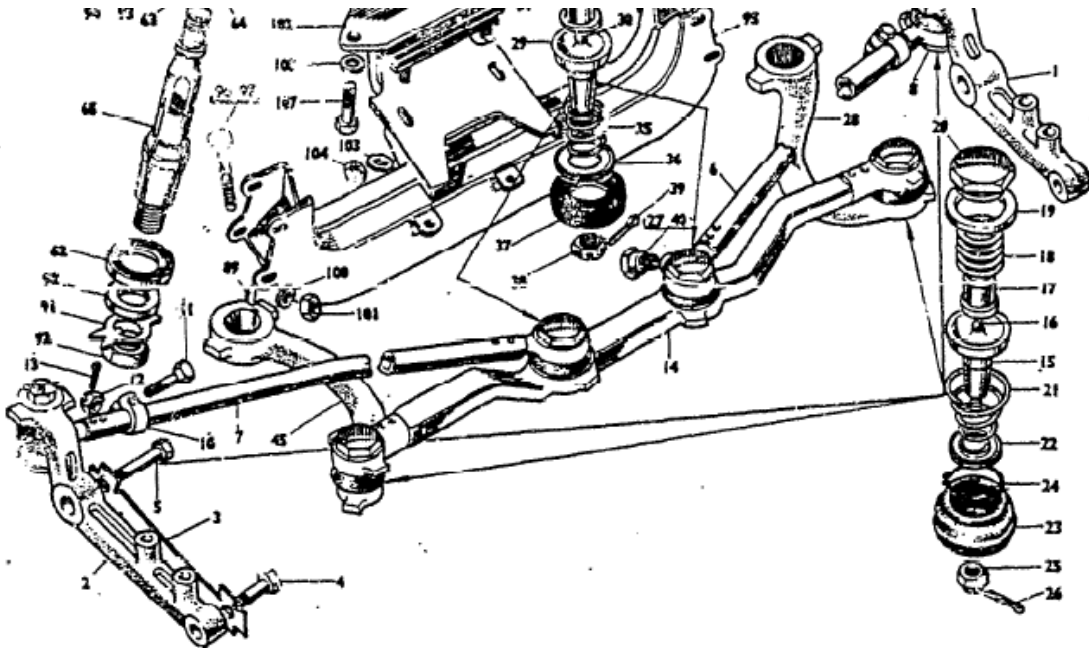

If you are still wondering, below is the general layout of the Shadow steering, number 28 is the offending item in the drawing above 2 in the drawing below.

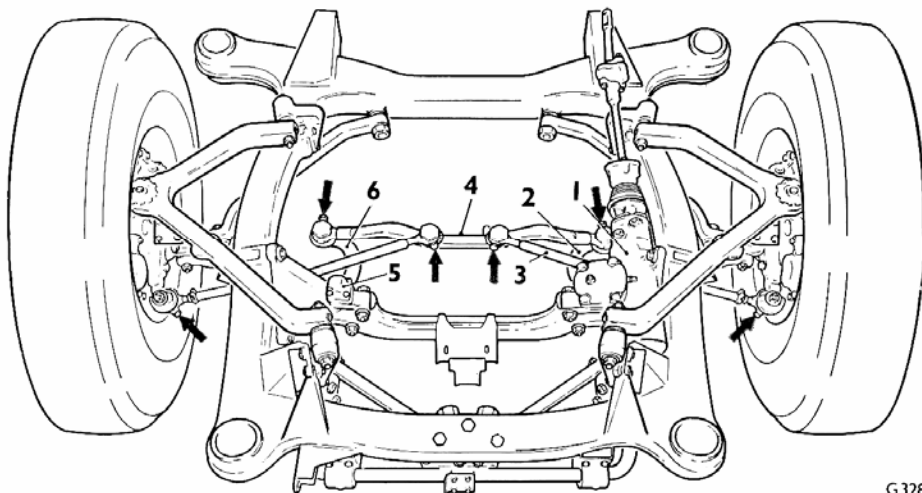

G328



## REMOVING THE BONNET ON AN SY OR SZ CAR

Many owners balk at this step but removing the largest single panel on the car is usually a step to retaining your temper, getting a job done better and finding things to fix that weren't obvious when the bonnet was on. Step one is to find an offsider who can wield a spanner (1/2" A/F), then cover the roof of the car with a blanket. Find a scribe (the metal type with a sharp point) and trace around the hinges where they bolt onto the underside of the bonnet. Disconnect and wiring to engine compartment lights and earthing strips if they are fitted. Remove the two top bolts from the hinge and one of the lower ones.



With your offsider armed with the spanner, stick your head under the bonnet and with the hand nearest the front of the car take a grip of the lower edge of the panel. You are then supporting the bonnet with your hand and the side of your head. Remove the last bolt and washer. Put the spanner down and carefully lift the bonnet free and place it on the roof.. Replacing it is the reverse but after bolting the thing in place carefully lower the bonnet to check that it is aligning correctly in the 'hole'. The slots in the bonnet under panel are elongated so that you have quite bit of movement to adjust the fit.



Step two

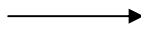

Step three

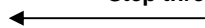





## HOLDING YOUR GAS

You would have all have seen the interior of a Shadow hydraulic accumulator. Well obviously this is the bottom half and the hole down there is where the nitrogen is forced in after the whole assembly has been assembled.

Having got the gas in, the problem is to keep it there. The original arrangement involved a simple valve consisting of a spring loaded steel ball bearing forced against a conical seat. Since the seat was not lapped there was an inevitable loss of gas when the charging hose was removed but it was

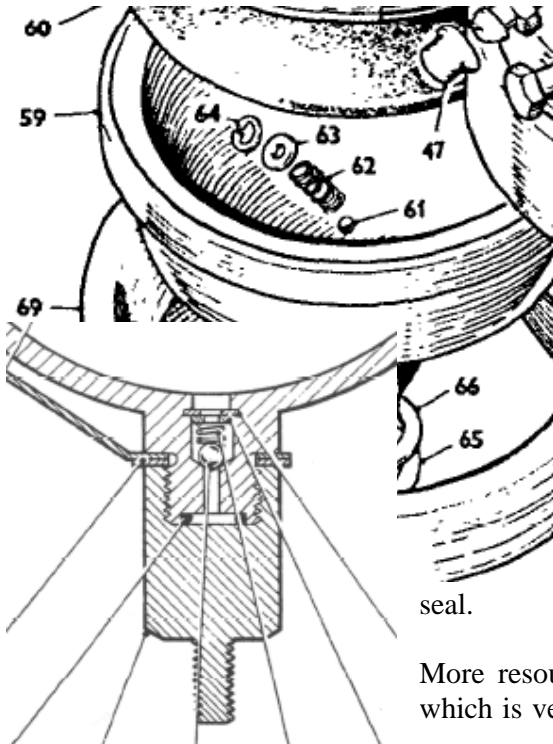

minimal and the arrangement gave you time to get the sealing cap on before the pressure dropped significantly.

At left is the general arrangement of the original valve. The steel ball (61) was initially held down by the spring (62). The recessed washer (63) kept the spring central in the hole and the circlip (64) kept the lid on. Of course once the nitrogen was pumped in at 1000 psi that also helped seal the valve. Valve in situ is shown in the drawing next below.

To overcome this loss some operators pop a flat nosed punch down the hole after the ball bearing and belt hell out of it with the intention of peening a seat that will not leak. Needless to say the seat suffers a lot of damage and while the initial bashing may work for that charging, the next time the thing is put together the dents in the ball don't match the dents in the hole and no amount of bashing will create a

seal.

More resourceful operators have designed a replacement valve which is very simple, consisting of a flanged plunger with a tiny



'O' ring threaded over the shank. This is dropped into the hole followed by the normal spring, retainer and circlip and the rubber 'O' ring is jammed between the plunger flange and the seating in the accumulator body.



At left is an improvement on the above arrangement in that the tapered tip facilitates the valves entry into the seat. Some operators have found that the seat has been bashed so hard that it was actually distorted the charging hole and the valve has difficulty fitting into it. This of course can be cleaned out by the judicious use of a drill.

I appreciate that this is highly academic to most readers but should you have the situation where your fixit man tells you that the accumulators on your Shadow won't

hold gas because of a faulty charging valve, keep the above in mind.



## SPACERS AND COMPRESSOR METRICATION

For those of you who are students of the spare parts manuals/CD's you would agree that it is fascinating the modifications the Factory was obliged to make to sell their cars to a wide range of



nationals. It must be a problem for the new masters noting their penetration into somewhat diverse markets. A recent example was the removal of the alternator on the Spur. Noting that the spares list showed three different alternators that could be fitted to the car and exercising common sense to the effect that no alternator maker is going to have his product built to the same dimensions as another, and noting that each alternator sat on basically the same frame I was alerted to the modifications that must have been necessary particularly those pesky little spacers. If you note the pictures, the arrows show the location of some of them. The point I am trying to make is to be aware of what bits should be there by consulting the spares diagram in the hope that you will find them all and know where each one goes.

Lastly many cars are now having their aircon compressors replaced. At the front as can be seen in the pictures, they are mounted on a threaded flange. Note that the thread can be either metric or imperial. Check before you start forcing bolts through them!



### **ADJUSTING FRONT WHEEL BEARINGS**

The specified end float of front wheel bearings on SY and SZ cars is .002" seen here being measured by a dial gauge. It is not often realised that the split pin holes in the stub axle are not at right angles to one another. This gives a little more facility to get the dimension correct. The pins are 5mm and are readily available from fastener and bolt suppliers.



## WATER PUMP REMOVAL AND REPAIRS TO LITTORALS.

There is a school of thought that water pumps on SZ and SY cars have an average life of 8 years. The Spur pictured above managed 22 years but decided to leak on the way home from Mudjee. Fortunately it was only drip and not as can happen a sudden loss of coolant. Getting the pump off is fairly straight forward remembering the different systems of fastening the fan to the water pump. Although it is quite possible to remove the pump with the bonnet power steering pump and alternator in place, I thought I would give the old girl a treat. So bonnet off which just makes it so



much more accessible. Off with the alternator and Steering pump and a decision to have the alternator overhauled even though it was performing perfectly. A good idea as it turned out as the regulator at the rear of the unit was found to have melted.

But it doesn't end there, the return hose on the upper hydraulic accumulator was found to be rubbing on the support bar for the power steering! That also was fixed with a fractional hose shortage!

When it came to unbolting the pump I managed to shear the head off every 1/4" bolt holding it. The task broadened. This meant that to get access to the broken bolts the water pump body needed to be removed. Well this was worthwhile as it

happened because the horrid little soft seal between the water pump body and lower timing case cover was well on the way to perishing as you will note the muck on the thing in the picture below.



I contemplated doing the pump myself but opted to let Bob Chapman in Melbourne do the job. He or at least Neil his son who apparently does most of the work down there, has a much better command of florid language when it comes to these tasks! Neil found that the main shaft of the pump had corroded under the seal. A new shaft was something of the order of \$1700 so Bob suggested a little hard chroming and grinding to spec. I agreed!

## **FUEL HOSES**

Having replaced the original rubber hoses from the body to the engine of the most neglected car in the Club some 3 years ago, I was shocked to see that they were cracking. The moral is - go for the very best when purchasing this stuff rather than 'let me have a length of fuel hose'!

