

**Bulletin**

MODEL: BENTLEY MARK VI

FOR INFORMATION:FRONT SHOCK DAMPER SETTINGS.Increased Bump Load.

Retailers are advised that a modified front shock damper setting is available for incorporation on cars which are reported as being subject to excessive 'front end lightness' or to the bump buffer hitting the front suspension bump stops when travelling at speed over rough roads.

The damping effect of each front damper unit is controlled by two spring loaded valves situated inside the damper casing; the bump valve, set at 65-70 lbs.(32 kilos) affects the damping on the upward movement of the front suspension, and the downward or rebound action is controlled by the rebound valve which is set at 125-130 lbs.(59 kilos).

This Bulletin describes the procedure for raising the loading of the bump valve by replacing the existing bump valve spring with a new spring of increased strength, raising the bump loadings to 95-105 lbs., the rebound loading remaining unaffected. The part number of the spring giving the 95-105 lbs. bump loading is RF.5022, these are obtainable from Hythe Road Service Depot.

It is important to note that the bump valve cap of the L.H. damper is at the FRONT of the damper casing, whereas on the R.H. damper, the bump valve cap is at the REAR. In each case, the rebound valve cap is on the opposite side of the casing.

Removal and replacement of the valve caps and springs, also the pumping action of the damper arm required to bleed the damper oil system of air, can be carried out easily and more efficiently if the damper unit is removed from the chassis frame as described in the procedure.

# Bulletin

MODEL: BENTLEY MARK VI

PROCEDURE:

- 1 -

1. Jack up the front of the car - jack under, and in the centre of the front 'pan'. Place wood blocks under the outer ends of the lower triangle lever and lower the weight of the car on to the wood blocks. The weight of the car must not be taken off the wood blocks until the job is completed, otherwise the road spring may become displaced.
2. Remove the front wheels. Remove the split pin, nut and the bolt from the Silentbloc bearing where the upper triangle levers form the joint at the top of the yoke. On removal of the bolt, the hub assembly will pivot on the lower joint of the yoke, and fall outwards unless it is prevented from doing so. A wood block of suitable height should be positioned on which the hub may rest, otherwise the weight will be taken by the flexible pipes of the hydraulic brake system.
3. Remove the three bolts and nuts securing the damper to the frame. On later cars, the outer fixing bolt is fitted the reverse way round, but provision is made in the bump stop bracket for a flat or ring spanner to be used for removal of the nut. Remove the damper and clean the casing, especially round the valve caps and the filler plug (6 in the attached sectional views of the front damper.)

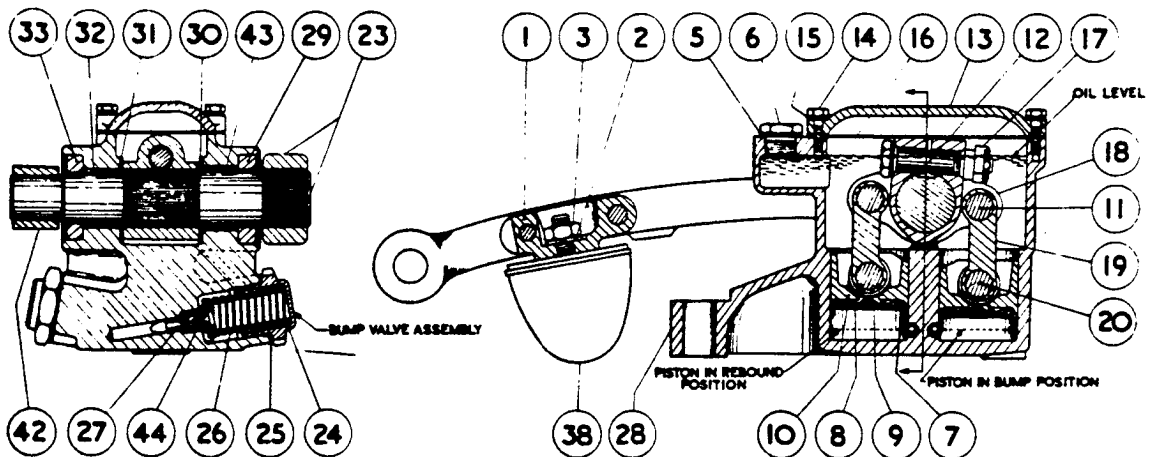

- |                                     |  |
|-------------------------------------|--|
| 1. Buffer Support.                  | 19. Connecting Link.                             |
| 2. Spring Washer.                   | 20. Pin-Piston & Connecting Link.                |
| 3. Nut.                             | 23. Triangle Lever(upper) & Main Shaft Assembly. |
| 5. Plain Washer(Alum).              | 24. Valve Cap.                                   |
| 6. Filler Plug.                     | 25. Plain Washer(Alum).                          |
| 7. Spring Ring-Replenishing Valve.  | 26. Spring-Bump Valve.                           |
| 8. Dished Plate-Replenishing Valve. | 27. Valve with bleed hole.                       |
| 9. Replenishing Valve Assembly.     | 28. Main Casing.                                 |
| 10. Piston.                         | 29. Gland Rubber-large-Main Shaft.               |
| 11. Pin-Rocker & Connecting Link.   | 30. Bearing Washer-in-large-Main Shaft.          |
| 12. Bolt(Spherical head)Rocker.     | 31. Bearing Washer-small-Main Shaft,             |
| 13. Top Cover-Damper Casing.        | 32. Bearing Bush-small-Main Shaft.               |
| 14. Setscrew-Top Cover.             | 33. Gland Rubber-small-Main Shaft.               |
| 15. Spring Washer-Top Cover.        | 38. Buffer-upper triangle levers.                |
| 16. Joint Washer-Top Cover.         | 42. Triangle Lever(upper).                       |
| 17. Nut(Spherical Seat).            | 43. Bearing Bush-large-Main Shaft.               |
| 18. Rocker.                         |  |
| 44. Valve Seating Bush.             |  |

ALL COMMUNICATIONS SHOULD BE ADDRESSED TO

BENTLEY MOTORS (1931) LTD. SERVICE STATION, MYTHE ROAD, WILLESDEN, LONDON, N.W.10



MODEL: BENTLEY MARK VI

- 2 -

4. Remove the bump valve cap (24), aluminium washer (25) bump valve spring (26), bump valve (27), also any packing washers which may be fitted between the spring and the cap.

Clean the parts and replace in the damper using a new bump valve spring in place of the old one which was removed, also remove any packing washers, but do not tighten the valve cap.

NOTE: For the above operation, it is recommended that the damper is bolted to a flat plate, approximately 7" x 7" x  $\frac{3}{8}$ ", to the back of which is attached a piece of angle iron. The plate may then be held firmly in a vice by means of the angle iron. The shock damper should not be held directly in a vice, as this is liable to cause distortion of the casing.

5. Remove the rebound valve cap, aluminium washer, also the packing washer (if fitted), spring and valve, (these are not shown in the illustration, but the arrangement is similar to that of the bump valve), clean the removed parts and replace in the damper, but do not tighten the valve cap.

Whilst carrying out these operations, oil will have been lost from the damper oil system and replaced by air. This must be expelled by the following method:-

6. Remove the oil filler plug (6) and using an S.A.E. viscosity 20 oil, top-up until the oil level reaches the bottom of the threads in the oil filler plug orifice. It is essential that the oil used for filling or topping up the dampers is perfectly clean.

The following are a few of the S.A.E. 20 proprietary brands of oil used in the United Kingdom, but any good quality S.A.E. 20 oil is suitable for this purpose.

|                            |             |
|----------------------------|-------------|
| Price's Motorine.....      | E           |
| Wakefield's Castrol.....   | Castrolite. |
| Vacuum Mobiloil.....       | Arctic.     |
| Shell.....                 | Single.     |
| Duckham's Adcoised.....    | NPA.        |
| Essolube.....              | 20          |
| Silvertown Speedolene..... | 20          |

7. If the upper triangle lever is moved up and down, a certain amount of free movement exists before any resistance is encountered. Both valve caps should be unscrewed until the triangle lever can be moved up and down without any damping effect being felt, then the pumping action of the triangle lever will bleed the system of air, if, at the same time the oil system is kept topped-up. The valve caps should be screwed in and the triangle lever operated to ascertain whether all free movement has been eliminated, if it has not, then the valve caps will have to be slackened off and the pumping and topping-up operation repeated until the free movement is eliminated.

ALL COMMUNICATIONS SHOULD BE ADDRESSED TO

BENTLEY MOTORS (1931) LTD., SERVICE STATION, HYTHE ROAD, WILLESDEN, LONDON, N.W.10

SE/DS.1/SF.15.12.47.

SECTION K



MODEL BENTLEY MARK VI

FOR INFORMATION:FRONT SHOCK DAMPER SETTINGS.INCREASED BUMP LOAD.

In the absence of a shock damper test-rig, it is possible that the desired increase in front damper poundage may not be achieved by fitting the valve spring RF.5022 specified in Bulletin BB-27.

It has been found that additional packing washers may be required, and this cannot be determined except by testing the damper.

A new spring RF.5021, has therefore been specified to give a 100-120 lbs. bump load without further adjustment, and all packing washers which may be found with the original spring should be discarded.

It should be noted that this spring will not be introduced on production, but will be a service replacement only, to be used for modifying shock dampers where a test-rig is not available.

**Bulletin**

MODEL BENTLEY MARK VI

FOR INFORMATION:CANCELS ISSUES DATED  
7.4.48 and 27.5.49.FRONT SUSPENSION SPRINGSTO REMOVE AND REPLACE OR FIT A NEW FRONT SUSPENSION SPRING

This Bulletin cancels the previous Bulletins Nos. BB-39 and BB-39a (Section K) and is issued for guidance in removing, replacing or renewing a front spring on early and later models. The procedure of removal having been amended in view of later experience.

NOTE: See para. 3 concerning a modification to the suspension spring compressing tool No. 3752/T1008.

CAUTION: Owing to the very high poundage of a front spring when fully compressed, due care must be taken when decompressing and compressing it.

1 TO REMOVE:

- (i) Jack up the front of the car - jack under, and in the centre of the front 'pan' and remove the front wheel.
- (ii) Remove the castle nut securing the ball end pin to the side steering lever. Collect the pressure spring and sealing disc and disconnect the outer end of the cross steering tube from the cross steering lever as follows:-
  - a) Place a substantial steady block in contact with the lever near the ball end pin to be removed, in order to provide a solid reaction point and then with the aid of a large steel drift and hammer, give the eye of the lever (adjacent to the ball pin) one or more sharp blows which will release the tapered shank of the ball pin from its location in the lever.
  - b) Before refitting a ball joint (ball pin) to a lever, clean the tapered shank of the pin and corresponding hole. Do NOT use a hammer when refitting a ball pin to a lever, but rely on tightening the nut to draw the mating parts together.

NOTE: The reason why it is necessary to disconnect the outer end of a cross steering tube when removing and replacing a front suspension spring, is that when the yoke is disconnected from the upper triangle lever, it allows the lower triangle lever to move beyond its fullrebound position, causing the neck of the ball end pin to foul the socket at the INNER end of the cross steering tube at point 'A' Fig.1. This damages the socket by raising a burr.

- (iii) Remove the two  $\frac{1}{2}$ " (B.S.F) nuts and the flat spring washers securing the bracket of the front stabiliser (anti-roll rod) to the lower triangle lever, and pull the bracket clear of the two studs.

# Bulletin

MODEL BENTLEY MARK VI

- 2 -

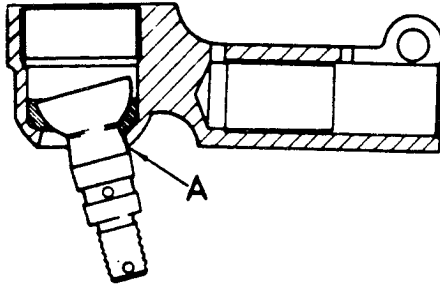

FIG. 1. BALL END PIN & SOCKET -  
INNER END OF CROSS-STEERING TUBE.

- (iv) Place the spring retaining bolt, Tool No.3752/T1002 downwards through the hole ('A' Fig.2) provided in the top of the front 'pan' and leave it in this position.

**NOTE - IMPORTANT:** To ensure full safety of the operator, the threads of the spring retaining bolt and its nut must be examined after each time the tool has been in use. If the threads are not found to be in good condition, then a new retaining bolt and nut should be obtained.

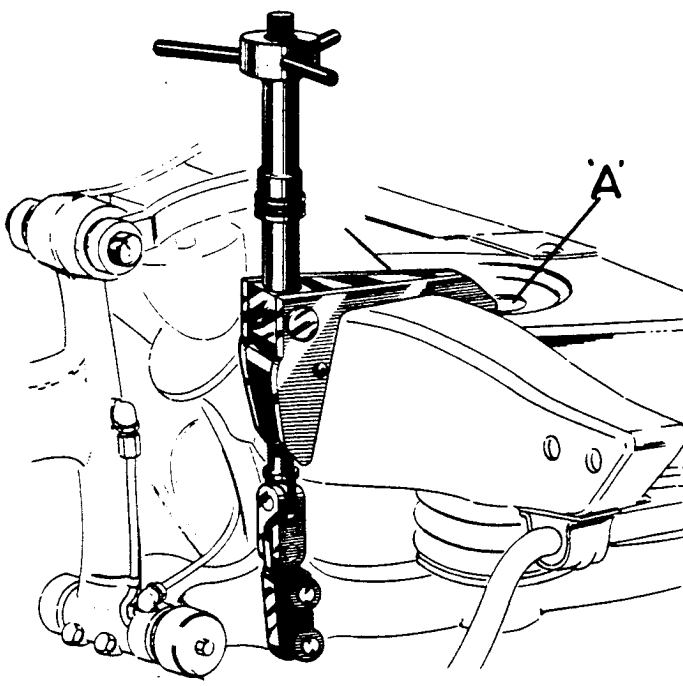

FIG. 2. SPRING COMPRESSING TOOL IN POSITION.

- (v) Place the lower end of the spring compressing Tool No. 3752/T1008 on to the two studs of the front stabiliser bracket and then place the claws of the tool so that they fit snugly under the lip (edge) of the hole in the top of the front 'pan' as shown in Fig. 2. Tighten up the two knurled nuts of the tool to secure.

- (vi) Fully compress the spring and then FULLY tighten up the nut of the spring retaining bolt to secure. While compressing the spring, guide the threaded end of the retaining

bolt through the hole provided in the lower buffer stop. (6 Fig.3 or 4 Fig.4). Leave the spring in position until the following operation (vii) has been carried out.

- (vii) While the hub is being held, remove the bolt from the Silentbloc bearing at the upper end of the yoke and allow the hub to swing over and rest on a block of wood.

- (viii) Release the spring compressing tool, which will allow the lower triangle lever to move in a downwards direction until the rubber buffer attached to the upper triangle lever rests on its stop. Remove the spring complete with its retaining bolt and temporarily reconnect the yoke to the upper triangle lever by means of a suitable tommy bar.

**NOTE:** It is not necessary to disconnect the flexible pipe either from its bracket on the frame or from the expander of a front brake during the above mentioned operations, but precaution must be taken when removing or replacing a front spring, not to allow any strain to be imposed on the flexible pipe.

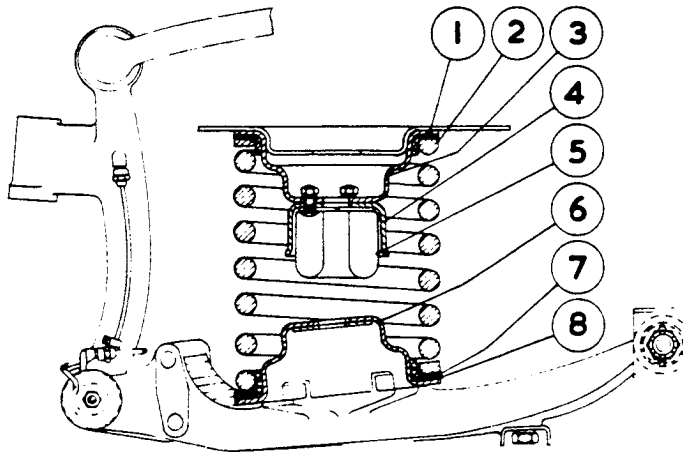

1. Spring seating (rubberised fabric).
2. Road spring.
3. Buffer carrier.
4. Buffer housing.
5. Buffer.
6. Buffer stop.
7. Spring seating (rubberised fabric).
8. Adjusting washer/s (if required).

FIG. 3. FRONT SUSPENSION SPRING IN POSITION - EARLY MODEL CARS.

## 2. TO CHANGE A FRONT SUSPENSION SPRING:

- (i) To fit a new spring, a "pot" STD-416 (Tackle, compressing and decompressing front road spring) will be required.
- (ii) Place the spring removed into the "pot" and clamp it down by FULLY tightening down the two outer nuts of the "pot".
- (iii) Remove the retaining bolt from the spring.
- (iv) With one of the two special washers correctly positioned on the long centre bolt of the "pot", pass the bolt through the bottom of it, place the other washer in position on the cover of the "pot" and then fully tighten down the nut of the centre bolt.
- (v) Remove the two outer nuts of the "pot" and carefully unscrew the nut of the centre bolt which will allow the spring to extend to its full free length.

(Cont'd).



MODEL BENTLEY MARK V.

- 4 -

**NOTE:** There may be one or more adjusting washers (8 Fig.3) at each end of a spring. These are inserted to attain the required standing height, and the quantity varies in relation to the poundage of available springs. It does not follow therefore, that the same quantity will be required if a spring is changed. It is usual when supplying a new spring to include with it the requisite number of adjusting washers.

If a given spring has for example five adjusting washers, then three should be placed at the lower end of the spring and the remaining two at the upper end in order to maintain adequate register on the buffer stops.

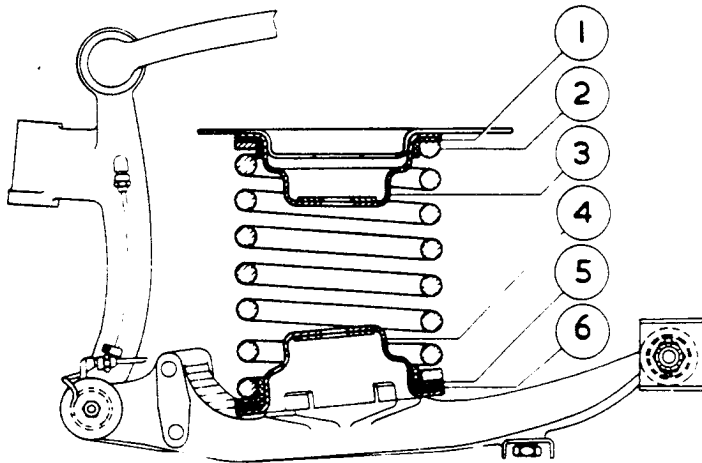

1. Spring seating (rubberised fabric)
2. Road spring.
3. Buffer stop(upper).
4. Buffer stop(lower).
5. Spring seating (rubberised fabric).
6. Adjusting washer/s (if required).

FIG. 4. FRONT SUSPENSION SPRING IN POSITION - LATER MODEL CARS.

- (vi) With the fabric spring seatings(1 & 7 Fig.3), the buffer carrier 3, (complete with buffer and housing) and the buffer stop 6, and adjusting washers (if any) in position on the new spring as shown in Fig.3, fully compress the spring by means of the "pot" and then FULLY tighten down the two outer nuts to secure.

**NOTE:** On later cars, commencing at Chassis Nos.B-466-EY & B-126-LEY on which "Progressive Bump Stops" have been incorporated, the buffer housing, 4 Fig.3 and the rubber buffer (5) have been eliminated (See Fig.4).

- (vii) Remove the centre bolt from the "pot", and in its place, fit the retaining bolt (3752/T1002) and FULLY tighten down the nut.
- (viii) Fit the spring to the car. As soon as the spring has been placed in position and fully compressed by the compressing tool, the yoke should be reconnected to the upper triangle lever by refitting the bolt. This should be done before removing the spring retaining bolt 3752/T1002. The castellated nut of the yoke bolt must only be fully tightened up and split pinned when the car has been lowered

(Cont'd)



# Bulletin

MODEL BENTLEY MARK VI

- 5 -

to the ground and bounced a few times and allowed to settle in its normally loaded state.

- (ix) Should it be found that when the spring is in position, that a coil of it is too near or touches the frame, this can be rectified by compressing the spring again and rotating it to a different position.

3. TO MODIFY AN EARLY TYPE FRONT SPRING COMPRESSING TOOL NO.3752/T1008:

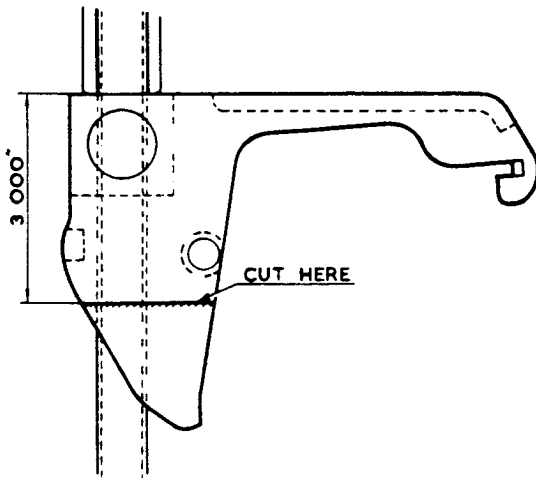

FIG. 5. MODIFICATION TO SPRING COMPRESSING TOOL.

In order to make the early type front spring compressing tool suitable for all types of chassis, the side plates of the clamp should be shortened to the dimension shown in Fig.5. A modified tool in this respect is shown in position in Fig.6. The later type production of this tool has shortened side plates.

On certain chassis it may be necessary to screw two adaptors (extension pieces) on to the two 1/2" (B.S.F.) studs at the front of the torque arm in order that a straight pull can be obtained with the tool when compressing a spring. These adaptors are shown in position in Fig.6. They are not supplied but can be made in accordance with details given in Fig.7.

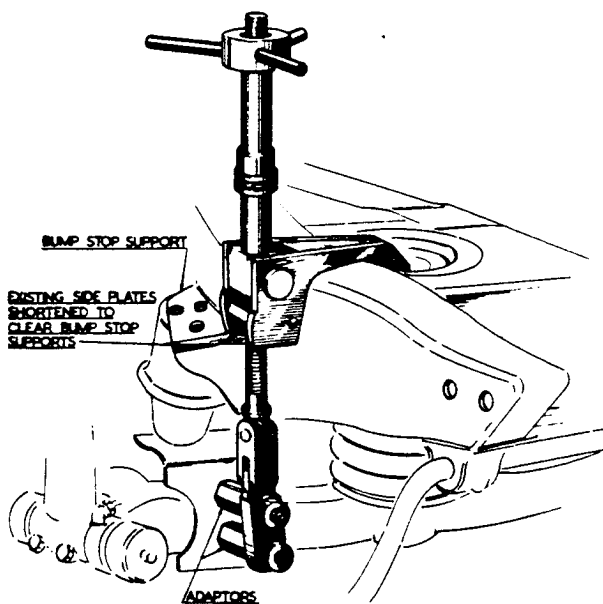

FIG. 6. MODIFIED SPRING COMPRESSING TOOL IN POSITION.

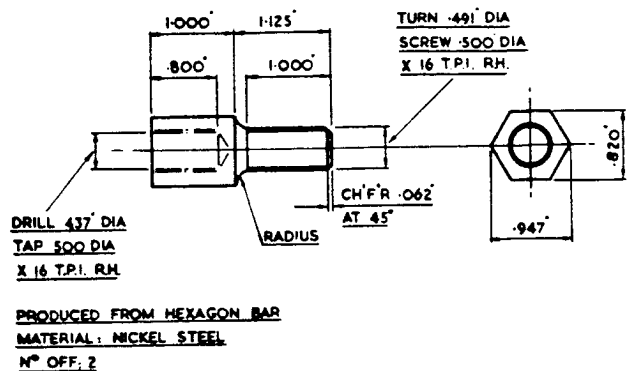

FIG. 7. ADAPTORS - STUDS - TORQUE ARM.

ALL COMMUNICATIONS SHOULD BE ADDRESSED TO BENTLEY MOTORS (1931) LTD., SERVICE STATION, WYTHE ROAD, WILMINGTON, LONDON.

### FRONT SUSPENSION & STEERING GEOMETRY

Questions frequently arise in service concerning the geometry of the front suspension, especially its effect on the steering and ride. The notes in this Bulletin will serve to draw attention to certain variables which may exist, and to indicate the method of treatment.

The variables which can exist in the geometry and which may be the subject of enquiry as to the effect on the steering and ride are as follows:-

#### SPECIFICATION

##### 1. STANDING HEIGHT (Height of Front Suspension)

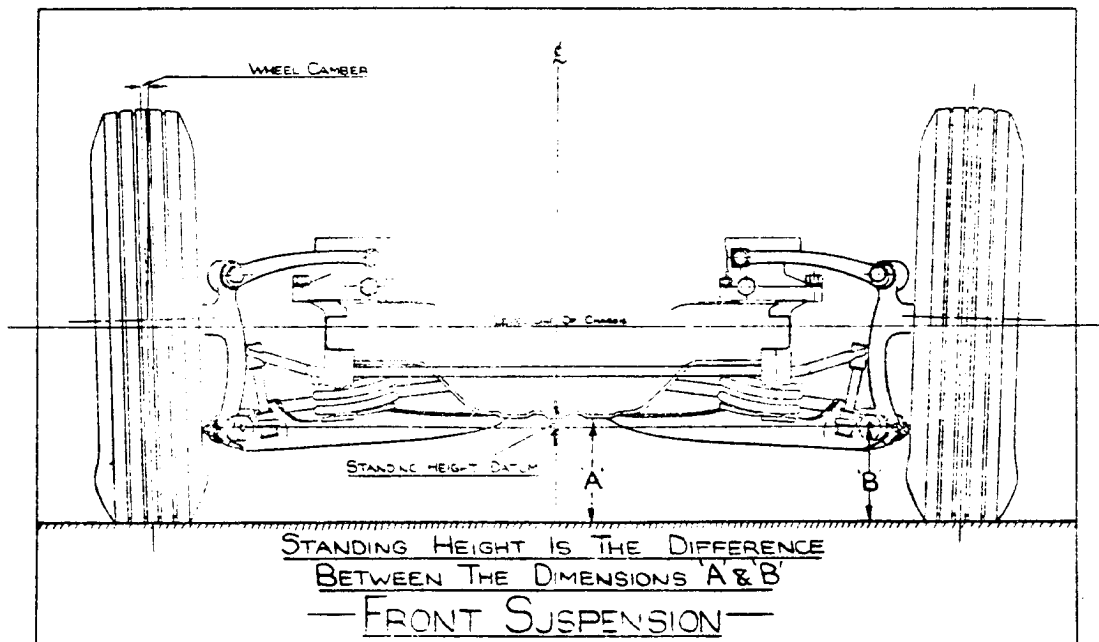

FIG.1.

The limits for standing height are:-

|                             |   |
|-----------------------------|---|
| Standard Suspension Springs | .700" to 1.350" (18 mm. to 34 mm.)<br>car unladen   |
| Colonial " "                | 1.350" to 2.050" (34 mm. to 52 mm.)<br>car unladen. |

##### 2. TOE-IN:

No variation is permissible, and this must always be set within the limits of  $\frac{1}{16}$ " to  $\frac{1}{8}$ " (1.6 mm. to 3.2 mm.) toe-in.

**Bulletin**

MODEL BENTLEY MARK VI

- 2 -

**3. CASTOR ANGLE:**

The limits for castor angle are:-

|                        |          |
|------------------------|----------|
| $3/4^{\circ}$          | positive |
|                        | to       |
| $1\frac{1}{2}^{\circ}$ | negative |

Adjustment up to a maximum change of  $1\frac{1}{2}^{\circ}$  is permissible as described later.

**4. WHEEL CAMBER:**

The limits for wheel camber angle are:-

|                       |         |
|-----------------------|---------|
| $\frac{1}{2}^{\circ}$ | outward |
|                       | to      |
| $\frac{1}{2}^{\circ}$ | inward  |

No adjustment is provided.

**5. SHOCK DAMPERS:**

The present standard loading for the front shock dampers is:-

|      |  |
|------|--|
| Up   | 95 - 105 lbs. ( $43 - 47\frac{1}{2}$ Kgs.)             |
| Down | 125 - 135 lbs. ( $56\frac{1}{2} - 61\frac{1}{4}$ Kgs.) |

Adjustment is possible, but it cannot be checked without a special jig, owing to leakage past the valves which is deliberately introduced.

**EFFECT OF THESE VARIABLES ON STEERING OR RIDE.****A. STEERING JOGGLES:**

Generally speaking, it can be said that the following settings will reduce steering joggles.

- (i) High shock damper poundage with possibly reduced slow leak in hot Countries.
- (ii) Standing height as near low limit as possible.
- (iii) Negative castor angle.
- (iv) Check balance of wheels and state of wear of tyres.

**Bulletin**

MODEL BENTLEY MARK VI

- 3 -

**B. COMPLAINTS CONCERNING THE RIDE:**

The best ride for average road conditions is obtained by:-

- (i) Standard shock damper loading.
- (ii) Standing height towards the bottom limits specified above.

**C. SUSPENSION CRASHES THROUGH:**

The best results for average road conditions are obtained by:-

- (i) High shock damper loading.
- (ii) Standing height adjusted to top limits.

Where this complaint exists Overseas on bad roads:-

- (i) High shock damper loading with reduced slow leak.
- (ii) Fit Colonial suspension springs which also increase the standing height.

Other complaints may exist such as steering pulling to one side which can be corrected by judicious adjustment of the castor angles.

**METHOD OF ADJUSTMENT.****1. STANDING HEIGHT:**

No precise instructions can be laid down, and each car must be individually considered in relation to the weight on the front wheels and the poundage of the springs at present fitted. Although certain packing washers may be fitted, it is not advised that extra packing washers should be added except on advice from the Main Service Station, owing to the fact that the coils of the spring may become choc-o-bloc before the bump offer is fully compressed. It is, however, permissible to remove any packing washers in order to lower the car if desired. The standing height will be reduced by twice the thickness of any washers removed.

In the event of any change in the standing height being required other than what can be achieved by the removal of packing washers, consult the Main Service Station, quoting if possible, the weight on the front wheels (car unladen).

Special high rating springs (7" deflection) are available for abnormal road conditions especially Overseas - these springs are called Colonial springs. They have the advantage of being able to absorb a greater amount of energy or road shocks, and therefore reduce crashing through. The ride, is, however, harder than with the standard suspension springs, although this may be more acceptable to certain Owners. If it is considered that Colonial springs would satisfy the Owner, full details of the complaint with particulars of weight on the front wheels should be forwarded to the Main Service Station.

**TO MEASURE THE STANDING HEIGHT:**

As shown on Fig.1, the standing height is the difference between the

ALL CORRECTIONS SHOULD BE ADDRESSED TO

BENTLEY MOTORS (1971) LTD, PYMS LANE, CREWE, ENGLAND

SECTION

**Bullseye**

MODEL BENTLEY MARK VI

- 4 -

Dimensions 'A' and 'B'. The measurements should be taken with the car unladen i.e. less driver and passengers and with five gallons of petrol in the tank. To measure, proceed as follows:-

- (i ) Check the front and rear tyre pressures and correct if necessary.
- (ii ) Place the car on level ground.
- (iii) Measure the distance from the ground to the underside (centre rib) of the centre plate of the front pan (Dimension 'A').
- (iv ) Measure the distance from the ground to the centre of the lower bearing of the yoke, i.e. the centre of the bolt which passes through the bearing (Dimension 'B'). Subtract 'B' from 'A' and record the reading obtained. Unless the standing height is far too low, Dimension 'A' is always greater than 'B'.

## 2. TOE-IN:

The tendency is for the front wheels to toe-out owing to settling down of the rubber in the suspension. Toe-out can usually be recognised by excessive wear on the inside of the right-hand front tyre, or, on the inside of the left-hand front tyre in Countries in which cars are driven on the right-hand side of the road. Excessive toe-in causes wear on the outside of the front left-hand tyre, or, on the outside of the right-hand tyre in Countries in which cars are driven on the right-hand side of the road.

It is important that the toe-in should be very carefully measured and accurately adjusted. Refer to the Workshop Manual, Section Q, Sub-Section BQ.2. Owing to inevitable "run-out" of the road wheels, it is recommended that the mean of two readings should be taken at opposite points on the wheel. The car should be rolled forwards half a revolution to take these two readings.

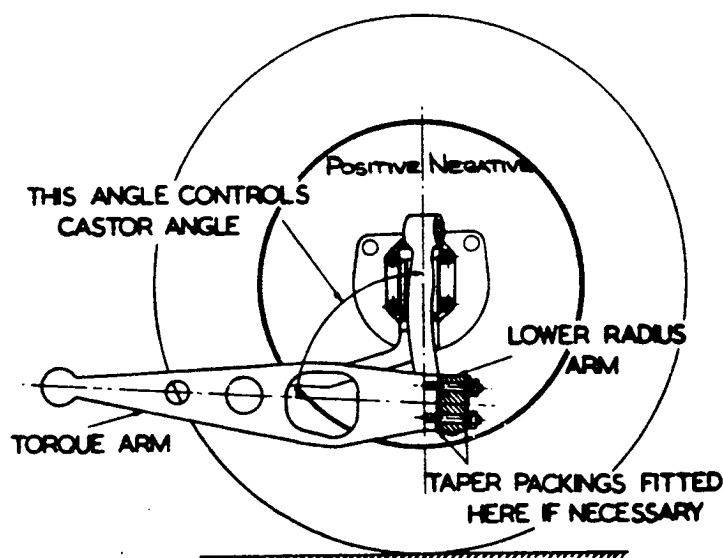

FIG. 2.

# Bulletin

MODEL: BENTLEY MARK VI

- 5 -

### 3. CASTOR ANGLE:

The castor angle is determined by the angle between the yoke and the torque arm as shown in Fig.2. It may be measured by a direct reading by means of a protractor and spirit level on the top face of the stub axle after removing the cover plate. This face is at right angles to the centre line of the king (pivot) pins.

The only way of altering the castor angle is to fit taper packings between the lower radius arm and the torque arm. Obviously in order to maintain parallelism of the abutment faces, an equal and opposite taper packing must be fitted on the outside of the radius arm i.e. between the radius arm and the bracket of the front stabiliser. Parallel packings may already be found between the torque arm and the radius arm. These are not for the purpose of adjusting the castor angle, they are fitted to line up the yoke in the upper triangle levers to avoid strain on the upper Silentbloc.

When taper packings are fitted, equal care must be taken to line up the upper end of the yoke in the triangle levers by the use of parallel packings if necessary. It must be remembered that when altering the castor angle, the upper end of the yoke should stay in the same position - the lower end being swung about this point.

If adjustment of the castor angle in a negative direction is required, the torque arm will probably need shortening in order to line up the upper end of the yoke in the triangle levers. If it is found that a parallel packing is fitted between the torque arm and the lower radius arm, then it should be removed, which will automatically reduce the effective length of the torque arm. The required reduction in length is 0.200" (5.08 mm) for each degree of alteration in the castor angle. This of course includes any packings which may be removed. The maximum amount which may be removed from the torque arm itself is 0.125" (3.17 mm).

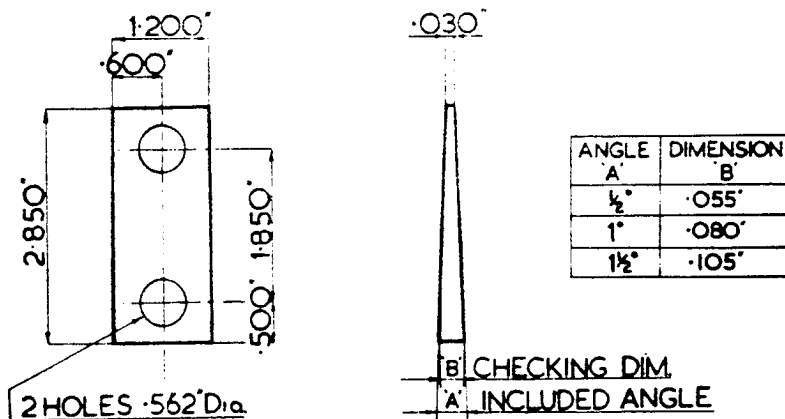

where castor angle is changed in a positive direction, it is possible that longer studs KB.963/Z-Torque arm will be required. A drawing of the taper packings required is given herewith (Fig.3) in order that they may be made up as required. The maximum change recommended is 1 1/2°.

MATL: LOW CARBON STEEL

FIG. 3.

**Bulletin**

MODEL BENTLEY MARK VI

- 6 -

4. WHEEL CAMBER:

No adjustment is provided, nor is it to be expected that any benefit would be achieved by any alteration. No dis-advantage has been found in a slight negative camber angle.

5. SHOCK DAMPERS:

Adjustment of the poundage is fully described in Service Bulletins Nos: BB-27 and BB-31 (Section K). Where still further damping is required, as in hot Countries, it is permissible in addition to plug up one of the two oil leak holes provided in each valve by removing the bump or rebound valve from the front dampers and soldering up the leak hole in the head of the valve, which communicates with the leak hole in the stem of the valve near the head. These two holes should not be confused with the three larger diameter equally spaced holes drilled in the stem of the valve near the centre.

ALL COMMUNICATIONS SHOULD BE ADDRESSED TO

BENTLEY MOTORS (UK) LTD., 87/88 LANE, CREWE, ENGLAND



MODEL BENTLEY MARK VI

TOE-IN OF FRONT WHEELS.FOR INFORMATION:

The attention of Retailers is directed to a change in the alignment settings for the front wheels of the Bentley Mark VI.

These are now 1/8" to 1/4" (3.2 mm to 6.5 mm) for the initial settings when a replacement has been made of all the Silentbloc bushes in the suspension system, and 1/16" to 1/8" (1.6 mm to 3.2 mm) when the front suspension has settled down.

This information has been included in the Workshop Manual, Section Q, Sub-section BQ-2, and Bulletin No: BB-74, and the relevant amended pages are included herewith.

CUSTOMERS SHOULD BE ADDRESSED TO

BENTLEY MOTORS (UK) LTD., SERVICE STATION, HYTHE ROAD, MILTON KEYNES, ENGLAND



**Bulletin**

MODEL : BENTLEY MARK VI

FOR INFORMATION:FRONT SUSPENSION & STEERING GEOMETRYCASTOR ANGLE.

Commencing at Continental Chassis No. BC-38-LC and subsequent chassis, the castor angle has been increased from  $1^{\circ}$  to  $1\frac{1}{2}^{\circ}$  POSITIVE by incorporating wider angled taper packings, Part No. RF-8070 in place of RF-8069 taper packings. These packings (4 off) are used in pairs on either side of the lower radius arms as shown in Fig. 2, of Bulletin No. BP-74 (Section K).

FRONT SUSPENSION AND STEERING GEOMETRY.(RIGHT-HAND AND LEFT-HAND DRIVE)FOR INFORMATION:1. DESCRIPTION:

Commencing at Chassis No.B.1-GT, the front suspension and steering geometry has been modified in various ways with the object of providing greater steering accuracy by eliminating certain geometrical errors which were present in the original design. The new design affects practically the whole of the front suspension and hubs, although in most respects the changes to individual parts are small and relate more to dimensions than to design. It is not possible to apply the revised design to existing cars.

The changes in the revised design are briefly as follows:-

- (i) The nominal frame height is raised .400" (10 m/m)
- (ii) The lower yoke bearings at the outer ends of the lower triangle levers have been raised 1.500" (38 m/m), thus reducing the angularity of the lower triangle levers by 1.100" (27.9 m/m) and increasing the ground clearance.
- (iii) The angularity of the upper triangle levers has been similarly reduced.
- (iv) The effective radius of the track rods and their angularity has been increased by interposing a third section between the two swinging track rods. This involves the use of an extra steering lever on the front pan.
- (v) Consequent upon the above changes, the free and loaded length of the front suspension springs is reduced by .600" (15 m/m), but the number of coils and the rating remain unaltered.
- (vi) The off-set of the point of contact of the tyres from the projected centre line of the pivots is reduced, the object being to reduce any disturbance of the steering if one brake is more effective than the other.
- (vii) Timken taper roller bearings are used in the front hubs instead of ball bearings, It is important to note the method of adjustment as described in Bulletin BB-95 (Section T).
- (viii) The method of balancing the wheels and tyres has been changed from a fixed position variable weight to a variable position fixed weight.
- (ix) The front brakes are re-designed and now embody internal hydraulic expander cylinders in place of the former Girling wedge system.

**Bulletin**

MODEL BENTLEY MARK VI

- 2 -

The equal wear linkage is re-designed and the brake shoes have been made more flexible to prevent brake "rumble" at high temperatures. (For setting instructions and external adjustment see Bulletin No. BB-96 in Section J.)

- (x ) The steering drop arm has been shortened to lighten the steering.

NOTE The upper triangle lever assembly of the front shock dampers is not interchangeable with the assembly fitted to chassis prior to Chassis No. B.1-GT, owing to the different angular setting of the lever in relation to the main shaft of the lever.

## 2. STANDING HEIGHT:

In consequence of the changes in the geometry of the radius arms mentioned above, the datum for measuring the standing height has been shifted relative to the ground as compared with the original design, and although the frame is .400" (10 m/m) higher than formerly, the reduced angularity of the lower radius arms means that the measurement of standing height can now become a negative figure.

The limits for standing height are:- (car unladen).

### (a) Standard Springs

.400" (10 m/m) negative  
to  
.200" (5m/m) positive

### (b) Colonial Springs

.600" (15 m/m) positive  
to  
1.200" (30 m/m) positive

A negative reading is when dimension 'B' Fig.1 is greater than dimension 'A'  
A positive reading is when dimension 'A' is greater than dimension 'B'.

## 3. TO MEASURE THE STANDING HEIGHT:

The measurements should be taken with the car unladen. i.e. less driver and passengers. To measure, proceed as follows:-

- (i ) Check the front and rear tyre pressures and correct if necessary.
- (ii ) Place the car on level ground - this is important.
- (iii) Measure the distance from the ground to the underside (centre rib) of the centre plate of the front pan (Dimension 'A').

- 3 -

- (iv) Measure the distance from the ground to the centre of the lower bearing of the yoke, i.e. the centre of the bolt which passes through the bearing (Dimension 'B').

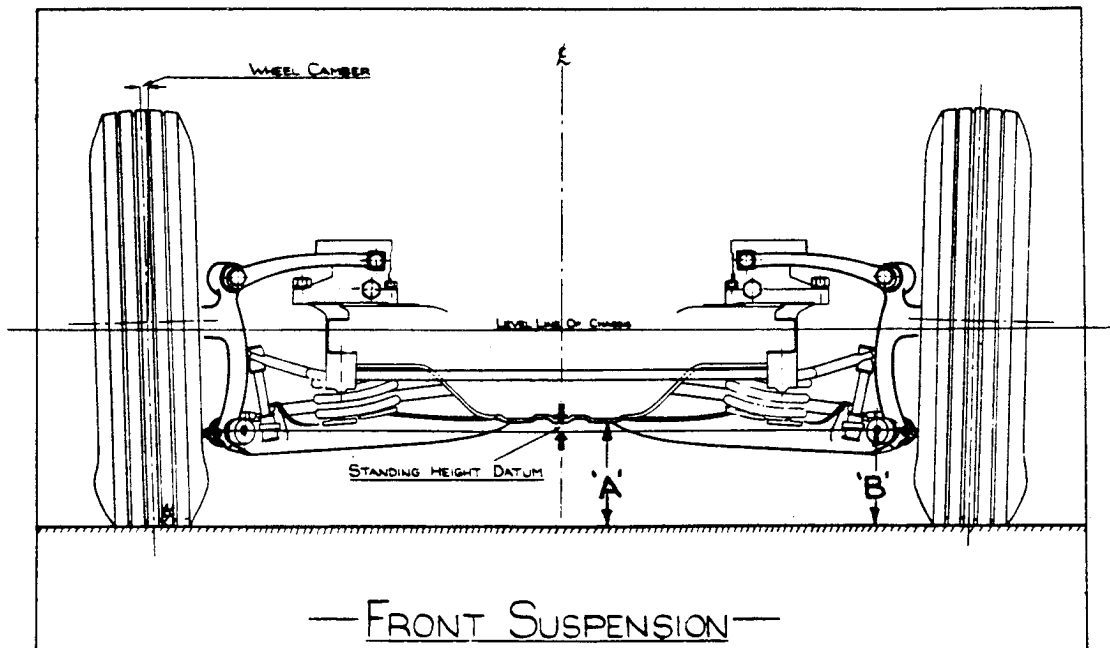

FIG. 1.

- (v) Subtract 'B' from 'A' and record the negative or positive reading obtained.

**NOTE:-** For method of adjustment of standing height, See Bulletin No. BB-74 in Section K.

#### 4. TOE-IN OF FRONT WHEELS:

The Factory setting of toe-in on new cars is  $5/32'' + \frac{1}{16}''$  ( $3.9 + .7$  m/m). This allows for the settling down of the various Silentbloc rubber bushes of the front suspension and this setting should be used if the Silentbloc bushes are renewed. Under normal running conditions, the toe-in must be set to within the limits of  $1/16''$  to  $1/8''$  (1.6 to 3.2 m/m).

#### 5. CASTOR ANGLE:

The limits for castor angle are,  $1/2^\circ$  positive to  $1\frac{1}{2}^\circ$  negative.

#### 6. FRONT WHEEL CAMBER ANGLE:

The limits for wheel camber angle are, 0 (Vertical) to  $1^\circ$  outward (with four passengers in the car). No adjustment is provided.

**Bulletin**

MODEL BENTLEY MARK VI

- 4 -

7. PIVOT PIN INCLINATION (ANGLE).Approximately  $4\frac{1}{4}^{\circ}$ . No adjustment is provided.8. SHOCK DAMPERS:The standard loading for the front shock dampers is unchanged,  
i.e.Up (Bump Load) 95 - 105 lbs. (43 -  $47\frac{1}{2}$  Kgs.)Down (Rebound Load) 125-135 " ( $56\frac{1}{2}$ - $61\frac{1}{4}$  Kgs. )

FOR INFORMATION:UPPER ROLLER BEARING ASSEMBLY-PIVOT PIN-FRONT SUSPENSION.

Whenever the stub axles have to be removed from a car for re-conditioning purposes as described in Sub-Section EK-2, of the Workshop Manual, opportunity must be taken during the re-assembling operations to check the inner roller race fitted to the upper end of the pivot pin for correct height in relation to its outer race. A condition can arise whereby the lower end of the rollers (A Fig.1) protrude below the lower edge of the outer race, i.e. at point 'B' due to an accumulation of adverse limits of machined parts. Fig. 2, shows the correct position of the rollers, i.e. the lower end face of the rollers are well above the lower edge of the outer race.

It should be noted that the information contained in this Bulletin and Sub-Section EK-2, applies to chassis numbers bearing the suffix letters AK, AJ, BE, BG, CF, CD DA, DZ, EY, EW, FV and FU.

Commencing at Chassis No:B-1-GT and onwards, this bearing assembly is altered to the needle type and this checking is unnecessary.

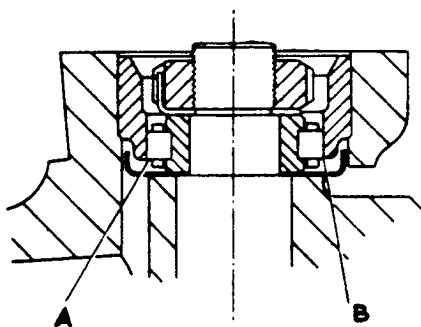

FIG. 1.

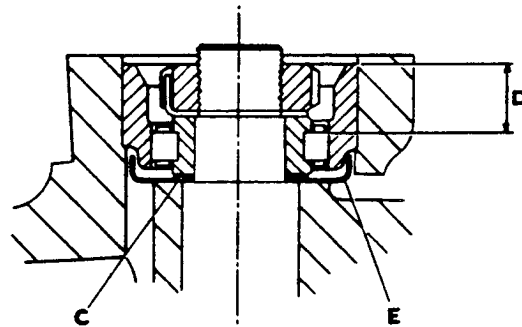

FIG. 2.

TO CHECK, PROCEED AS FOLLOWS:-

- (i) Having thoroughly cleaned all dismantled parts, including the bore in the yoke and the recess at its lower end against which the packing ring makes contact, and fitted new parts as found necessary (described in paragraphs 3, 4 and 5 of Sub-Section EK-2), refit the stub axle to its yoke in accordance with Sub-Paragraphs (i), (ii), (iii) and (iv) of paragraph 6.
- (ii) The next operation is to carry out the check previously mentioned. Having fully tightened up the nut at the top of the pivot pin, now remove the nut and the lockwasher beneath it, leaving the pivot pin in position.

**NOTE:** It is essential to make sure before making the undermentioned measurement that the upper outer race is fully home in its downward direction in the stub axle.

**Bulletin**

MODEL BENTLEY MARK VI

- 2 -

- (iii) Place a small straight-edge across the top face of the outer race of the upper roller bearing assembly of the pivot pin (not across the top face of the stub axle). With the rule of a small depth gauge, measure the distance downwards from the top face of the outer race to the top face of one of the rollers (not the brass roller cage), i.e. dimension 'D' Fig. 2 and note.
- a) If dimension 'D' is within the limits of .430" - .480" (10.9 - 12.2 m/m), this is correct.
  - b) If dimension 'D' is between the limits of .480" - .515" (12.2-13 m/m), then it will be necessary to remove the pivot pin and fit a .040" (1 m/m) thick packing washer ('C' Fig.2), Part No.R-4468, between the oil trough ('E') and the inner roller race.
  - c) If dimension 'D' is over .515" (13 m/m), fit two packing washers.
- (iv) Having refitted the pivot pin and fully tightened the nut, check that the stub axle can be moved freely from one full lock to another, apart from the normal drag caused by the felt washer at the lower end of the yoke.
- (v) Continue the re-assembling operations as described in Paragraph 6, of Sub-Section EK-2, commencing at Sub-Paragraph (v) and onwards.

Packing washers R-4468, will be supplied upon application to the London Service Station.

**Bulletin**

MODEL BENTLEY MARK VI

FOR INFORMATION:STEERING CHARACTERISTICS.

Some complaints have been received on relatively new cars of steering wander on a straight road, or of oversteer on corners. This Bulletin indicates the appropriate method of treatment.

1. WANDERING:

The tendency to wander on a straight road is due to too little castor effect combined with excessive friction in the steering joints or steering box. This complaint can be remedied by attention to the following:-

- a) The present castor angle may be negative (forwards) to the extent of possibly  $3/4^{\circ}$ . It can be made positive (backwards) by fitting taper wedges between the torque arms and the lower radius arms. Refer to Service Bulletin BB-74.  $1^{\circ}$  taper wedges will probably be adequate in most cases.  $1\frac{1}{2}^{\circ}$  wedges can be fitted if desired, but they tend to increase road shocks.
- b) The packings between the side steering levers and the swivel axle should be removed. The unwanted length of bolt can be made up by suitable packing washers under the nuts.
- c) The friction in the steering ball joints should be reduced where possible. The best condition for minimum friction is obtained by relieving the bedding on the spherical seat towards the largest diameter, i.e. maximum bedding near the bottom. Modifications are being made to the ball joints on future cars as follows:-
  - (i) The centre steering lever ball joints will have an anti-friction device interposed between the spring and the ball end.
  - (ii) The joint at the front end of the side steering tube will have practically all friction eliminated by the substitution of sixteen  $\frac{1}{4}$ " dia. balls for the existing seating.
  - (iii) The springs at the rear end of the side steering tube will have twice the rate but will be arranged to have zero load on the ball pin in the straight ahead position, instead of 196-lbs. as at present.

It is not intended that these modifications will be applied retrospectively except when complaints cannot be dealt with by the other treatment described.





MODEL BENTLEY MARK VI

- 2 -

- d) The pre-load on the steering cam bearings may be excessive. It has now been reduced on new cars. The total steering box friction (side steering tube disconnected) should preferably not exceed  $1\frac{1}{2}$  lbs. measured at the rim of the steering wheel.
- e) The state of wear of the front tyres affects castor and directional stability. New tyres represent the worst condition, but it is preferable always to fit the most worn tyres to the rear wheels in the interests of controllability.

## 2. OVERSTEER:

The new geometry steering cannot be made to have the marked understeer characteristics of the old steering geometry, but a few things can be done to improve matters:-

- a) The pressure difference between the front and rear tyres should be at least 7-lbs., preferably 9-lbs., cold. Recommended pressures for the Bentley Steel Saloon are 23-lbs. front and 32-lbs. rear.
- b) Always fit the least worn tyres on the front wheels.
- c) Understeer can be improved slightly at the expense of joggles, by raising the front of the car to the top limits of standing height.
- d) On certain coachbuilt cars with a lot of overhang, an improvement can be effected by fitting flanged Silentbloc bushes to the inner ends of the lower triangle levers. Apply to Hythe Road for details in this case.

-----oOo-----

**Bulletin**

MODEL: BENTLEY MARK VI

FOR INFORMATION:CROSS STEERING LEVER BOLTS

With the introduction of the revised steering geometry from chassis number B.1.GT onwards, a packing piece was fitted between the cross steering lever and the flange on the stub axle assembly to which the cross steering lever is bolted. It has been found that this packing piece is not essential and it has been deleted on production from chassis number B.89.PU onwards. In consequence shorter bolts, part number FB.4991, are fitted in place of the bolts RF.8198, and are the only bolts now available as replacements.

Should it at any time be necessary to replace the cross steering lever bolts, the shorter bolts, FB.4991, should be fitted and the packing piece discarded.

**Bulletin**

MODEL BENTLEY MARK VI

CATEGORY 3aMODIFICATION  
FRONT SHOCK DAMPERS KNOCKS.

Cases have occurred of an intermittent knocking from the front suspension system which has been traced to the replenishing valves in the front shock dampers. The knock is recognisable as a distinctive metallic clicking or tapping which is transmitted up the steering column. It is normally intermittent and is, of course, more noticeable on rough road surfaces.

1. Piston.
2. Replenishing Valve Assy.
3. Dished Plate.
4. Spring Retaining Ring.

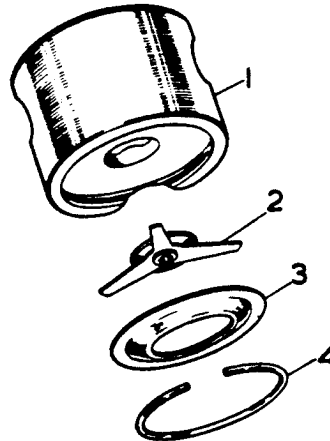

SHOCK DAMPER PISTON AND  
REPLENISHING VALVE.

A new replenishing valve assembly has been designed with a stronger stop plate spring and is immediately effective in eliminating the knock. The valve is now fitted on current production and is available as a service replacement. The illustration shows the new valve assembly which may be distinguished from the earlier type by the plain washer under the rivet head.

Retailers should fit the new replenishing valves only after a road test has confirmed the diagnosis. Full details for dismantling and re-assembling the front shock dampers are given in Section K of the Workshop Manual.

Parts Required.

RF.10311 SA Replenishing Valve Assembly 4 Off.