



MODEL BENTLEY MARK VI

MODIFICATIONIGNITION COIL INPUT SUPPRESSOR

To reduce electrical interference to the radio from the ignition system, a suppressor unit, (1. mfd. Part No. RD.4031.) is being introduced to the INPUT side of the ignition coil on all cars now being manufactured.

The suppressor is attached to the coil bracket by either of the two existing fixing bolts, the lead being connected to the switch wire (S.W.) terminal of the coil.

Some cars already in service require the incorporation of this modification, and Retailers in whose area these cars are normally kept should take the necessary action.

A visual check of the ignition coil will verify whether this modification has been incorporated; and, if so, whether the suppressor lead has been connected to the switch wire (S.W.) terminal, and NOT to the output (C.B.) terminal of the coil.

A sufficient number of suppressors to cover requirements is being despatched to Retailers overseas, and Retailers in the United Kingdom will be supplied with the necessary parts to cover the cars in their respective areas on application to this Service Depot.

Will all Retailers kindly inform this Service Depot concerning cars on which they carry out this modification.

Bulletin

MODEL : BENTLEY MARK VI

M O D I F I C A T I O N .HORN PUSH BUTTON ASSEMBLY.

A modification is introduced to the horn push button assembly to give additional strength where the contact pillar is screwed into the horn push. The alteration consists of the substitution of the taper pin locking by sweating.

Retailers are requested to modify any cars listed below which are in their respective areas when they come in for servicing or other work.

The letter 'P' will be stamped on the near-side lug of the steering box as a visual means of indicating that this modification has been carried out on any of the individual cars referred to in this Bulletin.

Cars requiring modification are as follows:-

- B - AK Series. Chassis Nos.....All cars.
- B - AJ Series. Chassis Nos.....1 to 68, 70 to 138, 140 to 160,
174 to 184 - all figures inclusive.

It should be noted that from Chassis No.B185AJ onwards the modification will be incorporated during manufacture, and the letter 'P' will not be stamped on the steering box.

To minimise delay a sufficient number of contact pillars is being despatched to Retailers overseas to cover the modifying of cars in their respective areas. Retailers in the United Kingdom will be supplied with new contact pillars on application to this Service Depot.

Will all Retailers kindly inform this Service Depot concerning the chassis numbers of individual cars which they modify.

The alteration should be carried out free of charge to the customer.

P R O C E D U R E .

Fig.1. Remove clip fastening horn wire to off-side valance plate and anti-chafing bush from tube at bottom of steering box, remove the pinch bolts and slide the throttle, riding and mixture control levers downwards off their tubes.

Loosen tab washer and remove the nut 'A' from the threaded taper piece 'D'.

Remove the near-side nut 'B' and its lockwasher.

Temporarily fit the nut 'A' back onto the threaded taper piece three or four threads and give it a few sharp taps towards the steering box to loosen the threaded taper piece from its seating. after which the nut can be removed and slipped downwards over the tubes. A receptacle should be placed at the bottom of the steering box to catch the oil that will be lost during the next operation.

Fig.2. The centre assembly of the steering wheel boss is now free to be pulled out of the steering column $1\frac{1}{2}$ to 2 inches, sufficient to allow removal of the three bolts from the underside and thus separate the horn push button and the cover from the lower half of the assembly.

From the horn push button unit tap out the taper pin 'H' and remove the contact nut 'J' and the brass washer 'G'. The push button and its contact pillar 'F' is now free to be removed from its cover.

Tap out the taper pin 'E' from the contact pillar and unscrew the pillar from the button. This contact pillar, with holes drilled through both its threaded portions, and the taper pin 'E' can be discarded.

A new contact pillar, with its top threaded portion tinned with solder is screwed and sweated into the push button.

Temporarily assemble the push button unit and spring in the cover (leaving out the taper pin 'H'), refit to the lower half of the assembly.

A distance of .040" between the contacts is desirable, and this is obtained as follows:-

Measure the distance with a stack of feeler gauges between the underside edge of the push button and the cover. Reduce the stack of feelers by .040", and when the button is pressed, the horn should start to sound just as the button nips the stack of feelers.

The amount of this travel is regulated by the thickness of the brass washer 'G'. If the horn sounds before the button nips the feelers, the brass washer requires reducing in thickness, but if a greater travel than .040" is obtained before the horn sounds, then a thicker washer is required.

When the correct amount of travel is obtained, the contact pillar is drilled through the existing holes of the contact nut 'J' and the taper pin 'H' fitted. The unit may now be finally refitted in the steering wheel hub.

Refit nuts, tab washers, throttle, riding and mixture control levers on their tubes. Ensure that the riding and mixture control levers give their full amount of travel and that the hand throttle control lever commences to open the throttle at the seventh notch from the fully closed position on the quadrant. Refit the anti-chafing bush and the horn wire slip on the valance plate. Refill the steering box with oil.

Stamp the letter 'P' on the near-side lug of the steering box as indicated in the drawing.

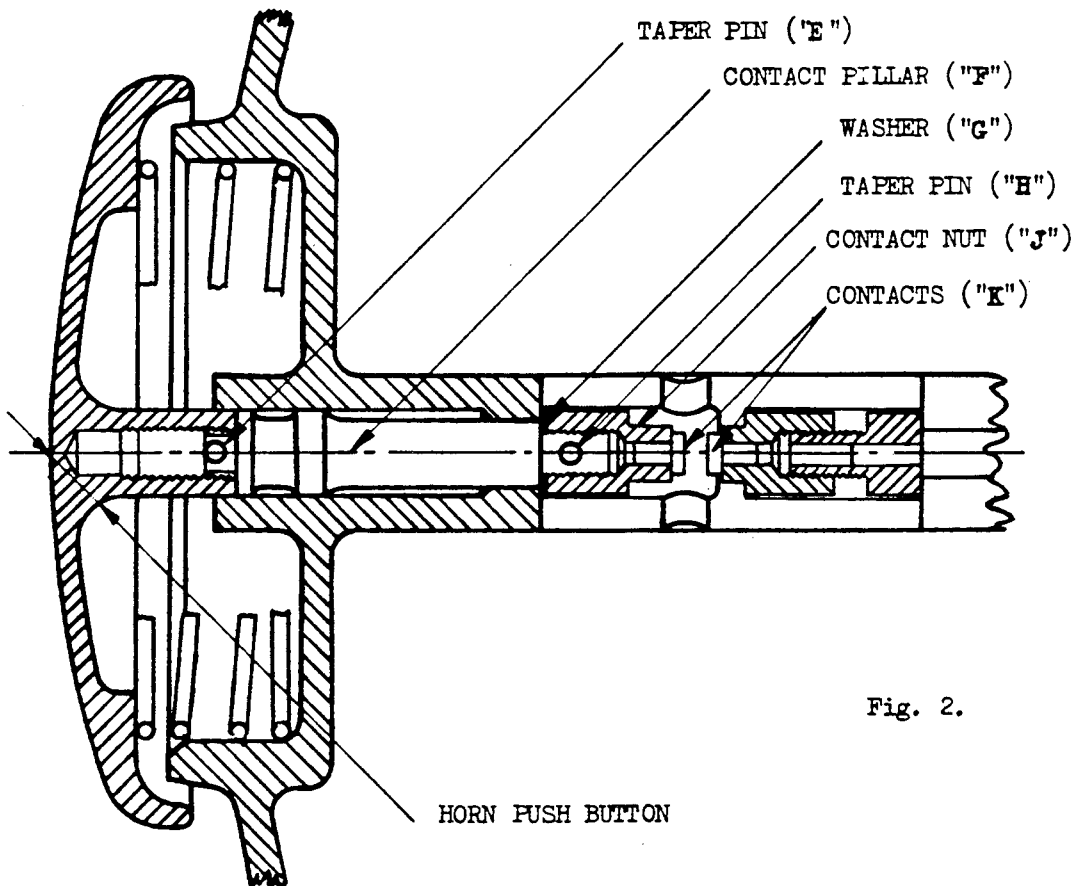
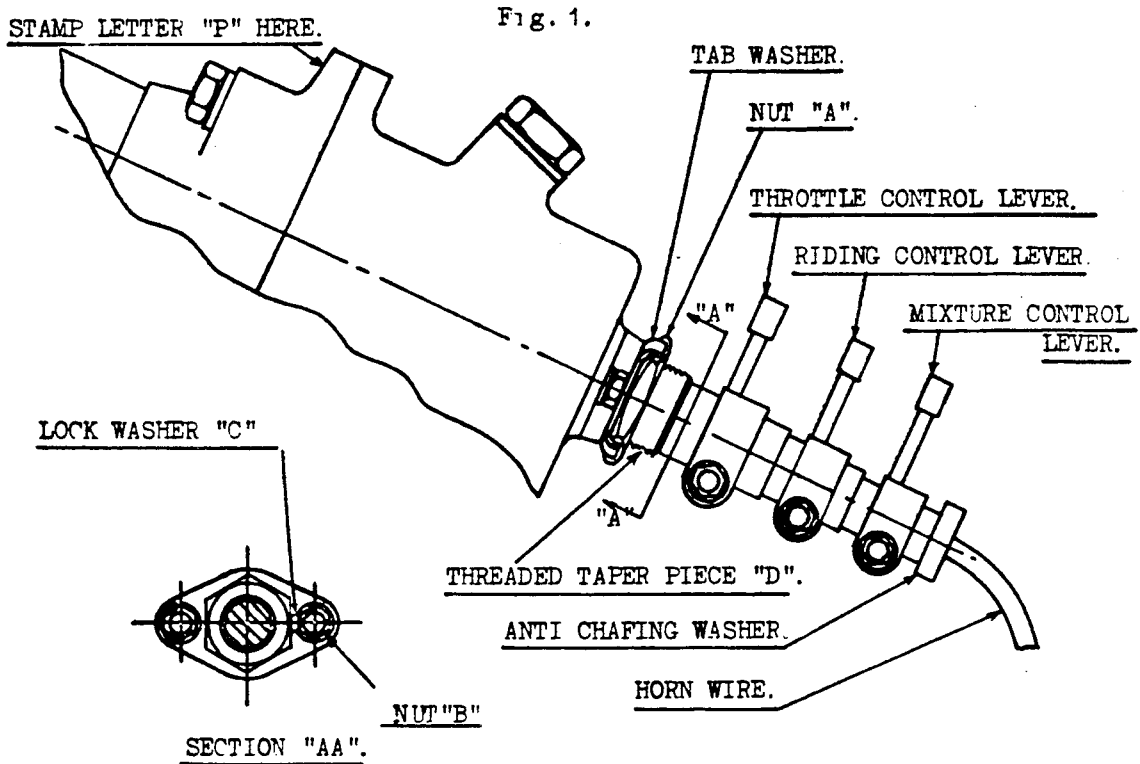

Illustrations and text reproduced by permission of BENTLEY MOTORS (1911) LTD. SERVICE STATION, 45 THE ROAD, WILFORDEN, LONDON, N.17

MODIFICATION.CATEGORY: 3A.WINDSCREEN WIPERS - ELIMINATION OF NOISE.

The information contained in this Bulletin is issued for guidance in the event of complaint being received concerning the noisy operation of windscreen wiper equipment and covers a recommended procedure for dealing with this matter.

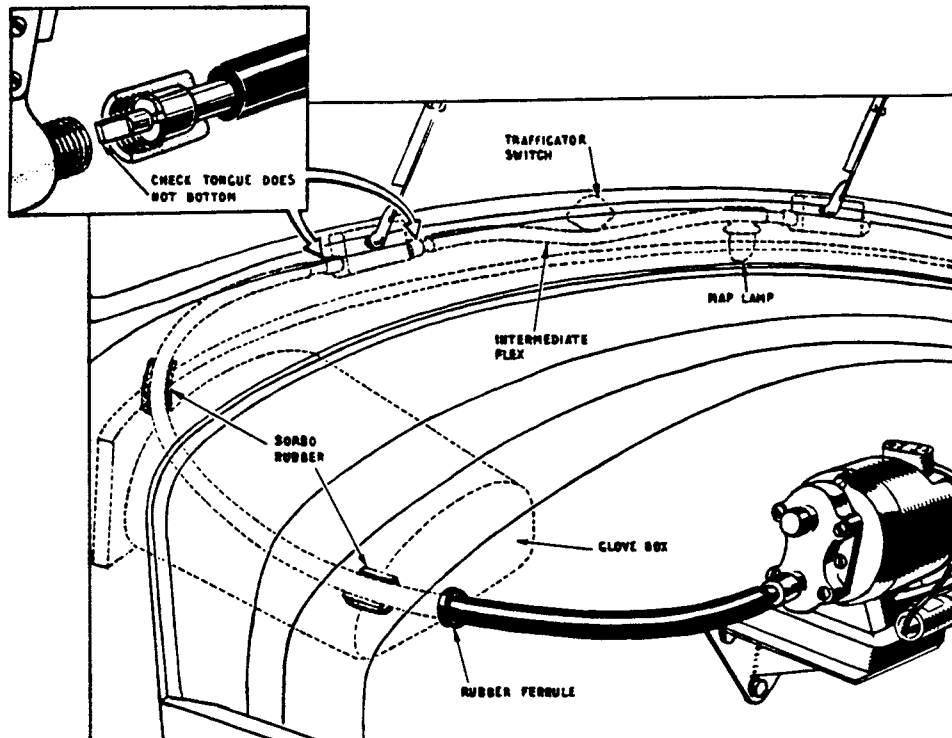

The windscreen wipers are operated by gearboxes and flexible cable drives from an electric motor mounted on the off-side front of the dash.

It has been found that noisy operation may be due to any of the following causes:-

- (a) Flexible drives fouling the scuttle rail or glove box.
- (b) Rigid attachment of the gearboxes to the scuttle rail.
- (c) Awkward bend in flexible drive or bottoming of tongues.
- (d) Noisy gearbox.

Bulletin

MODEL BENTLEY MARK VI

- 2 -

In the event of it being necessary to gain access to the wiper mechanism, it will be necessary to remove the screen finisher and facia board; this on coachbuilt bodies is sometimes built up in sections and only the facia board enclosing the gearboxes will require removal. The screen finisher and facia board on the Bentley Standard Saloon however, is of the one-piece frame type and the procedure for removing this is as follows:-

Remove the driving mirror; traffic indicator switch and windscreen wiper knobs. A strip of cloth glued in position underneath the facia board will have to be pulled away to gain access to, and remove the two nuts fixing the "grab" handle and facia board to a metal plate on the scuttle rail on the near-side, and one nut on the off-side. Remove the screws from the screen finisher and pull the top portion of the framework away from the screen and lift upward about $3/16$ " , sufficient to clear the top of the demister pipes over which the facia board fits. The complete framework should now be free for removal from its setting.

Having removed the screen finisher, switch on the wipers with the arms removed and listen for noise. Check that the flex does not foul at the points shown in the sketch and if necessary, add small pieces of sorbo rubber to prevent contact.

Slack off the gearbox fixing screws and see whether the noise is appreciably diminished. Rubber sheet in place of the felt mounting pad will be found to effect an improvement. The screws can be left only partially tightened with perfect safety.

If the noise persists, check that the driving tongues do not bottom in the slots; if necessary, shorten them by filing. Also make sure that the intermediate flexible drive is in the best position for lack of noise by slacking off the knurled nuts and twisting the outer flex to a new position.

In the event of it being established that the gearboxes themselves are unduly noisy, apply to this Service Station for replacements and return the old gearboxes for examination.

WIPER ARMS AND BLADES:

In the event of complaint being received concerning wiper blades that cause smearing of the screen, these will be replaced by a new type arm (Part No:RD-4138) and blade (Part No:RD-4139) on application to this Service Station, quoting the chassis number of the car for which they are required and returning the old parts for examination.

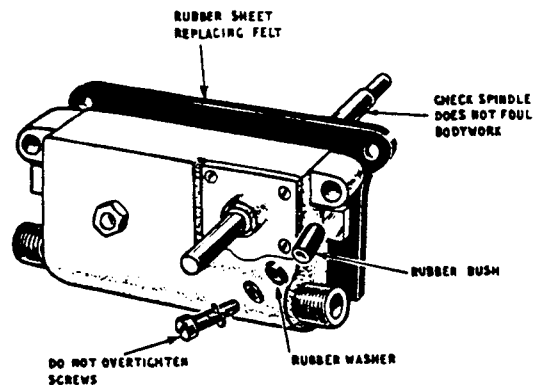

MODIFICATION.

FOR INFORMATION:
and action if necessary.

RADIO INTERFERENCE.

A few cases of radio interference from the "Windtone" horns have been reported.

To obviate this, a modification is to be introduced incorporating a suppressor condenser within the horns.

Where this trouble occurs on chassis without the modified horns, it can be eliminated by fitting an external suppressor in the feed circuit to each horn junction box.

METHOD OF FITTING THE SUPPRESSOR:

1. Remove the screw holding the loom securing clip to the inside of the wing valance.
2. Slip the suppressor bracket between the wing valance and loom securing clip, locate the screw in the bolt hole, and tighten up.
3. Remove the cover from the front junction box and identify the terminal to which the horn INPUT lead is connected. (This can be readily identified by first locating the horn INPUT lead from under the wing.)
4. Connect the suppressor lead to same terminal. (Before carrying this out, cut off the flat terminal at free end of suppressor lead, remove the small rubber sleeve, and bare just sufficient wire to effect a satisfactory connection).
5. Replace the junction box cover, and secure same.

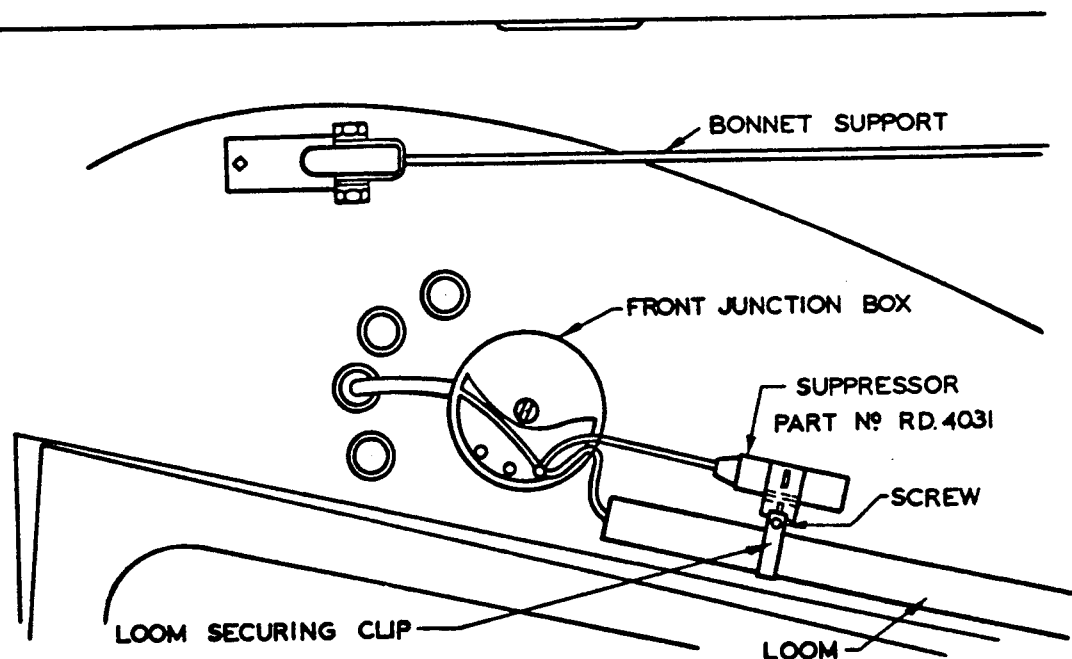

FOR INFORMATION:ALTERATION IN FUSE WIRE GAUGE.

To provide increased protection to the electrical system on Bentley cars, it has been decided to reduce the gauge of the fuse wire on both the main and circuit fuses to 32 S. W. G. This gives a fusing value of approximately 30 amps. on the circuit fuses, and with three strands on the main fuse 90 amps. , replacing the previous fuse wire of 30 S. W. G. which gave 40 and 120 amps respectively.

Will Retailers please note that when existing stocks of 30 S. W. G. wire have been consumed replacements will consist of 32 S. W. G. tinned copper wire.

This Bulletin cancels BB-23 issued on the 17. 11. 47.

Bulletin

MODEL : BENTLEY MARK VI

MODIFICATION.CATEGORY 2:ADDITION OF SUPPRESSOR CONDENSER TO SPARE IGNITION COIL.

A modification is introduced to obviate the necessity for moving the existing ignition coil suppressor condenser when the spare ignition coil is being used. In conjunction with this modification, a clip is fitted to the dash to group the coil wires together and rubber sleeves to the wires to prevent chafing.

Modification action will be required on cars with chassis numbers as follows:-

P123AJ	to	R247AJ
F2EH	to	B400BH (except B394FH)
B1EG	to	F25BG (except B11EG, B21EG and B23EG).

All numbers inclusive.

The above cars are fitted with twin ignition coils, a suppressor condenser to the N/S coil and ignition wiring of sufficient length to reach either coil.

MATERIAL REQUIRED:

Assembly No:	RD4031	consisting of	
		Condenser 1 mfd.....	1 Off
		Rubber sleeve.....	1 "
		Cable eye.....	1 "
Part No:	RD3434	Trimount clip.....	1 "
" "	RD3305	Rubber sleeve.....	3 "

SUPPRESSOR CONDENSER:

This is to be fitted to the off-side fixing bolt of the off-side ignition coil bracket and the suppressor lead connected to the INPUT (S.W.) terminal of the coil.

TRIMOUNT CLIP:

A hole .250" diameter should be drilled through the dash at the point indicated in the attached drawing. This position is immediately behind and on a level with the top of the rocker cover which can be removed to facilitate drilling the hole. The rocker gear should be covered to prevent the entry of swarf during the drilling operation. The drill should not penetrate the dash more than 5/16" as this will cause damage to the insulation situated immediately at the rear of the dash.

RUBBER SLEEVES:

These should be positioned on the wires as shown in the attached sketch. The wires should be connected to the off-side coil, the radio switched on and the engine run to check the suppressor and the ignition coil for correct functioning. The wires can be left connected in this position, the near-side coil becoming the spare.

ALL COMMUNICATIONS SHOULD BE ADDRESSED TO
BENTLEY MOTORS (1931) LTD. SERVICE STATION, HYTHE ROAD, WILLESDEN, LONDON, N.W.2

SECTION

P

Bulletin

MODEL: BENTLEY MARK VI

- 2 -

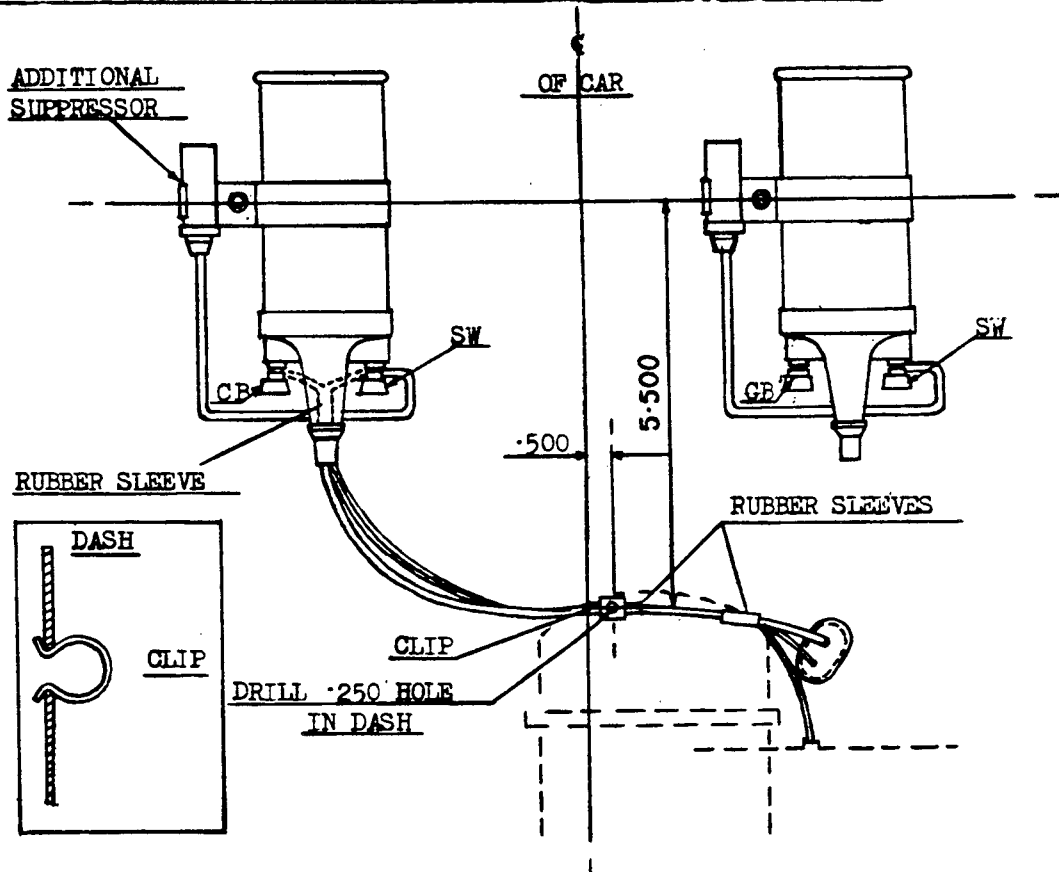
RUN OF WIRING, POSITION OF CLIP, RUBBER SLEEVES AND SUPPRESSORS.CARS ON WHICH MODIFICATION ACTION IS NOT NECESSARY:

Chassis No: B2AK to B254AK

" " B1AJ and B3AJ

Cars with the above chassis numbers have only 1 coil fitted, being built and delivered to customers prior to the introduction of the spare coil.

Cars with chassis numbers B5AJ to B121AJ were built prior to the introduction of the spare coil, the ignition wiring being of sufficient length to reach the one fitted coil, but a spare coil was provided on the dash before delivery to the customer. Use of the spare coil on these cars necessitates a change-over of the coils.

The modification is being incorporated during manufacture on cars with chassis numbers from B27BG and onwards.

Retailers can obtain the necessary material for carrying out this modification on application to Hythe Road Service Station, chassis numbers of cars to be quoted for which the material is required.

ALL COMMUNICATIONS SHOULD BE ADDRESSED TO
BENTLEY MOTORS (UK) LTD. SERVICE STATION, HYTHE ROAD, WILLESDEN, LONDON, W.7

CHECKING IGNITION TIMING.FOR INFORMATION:

The ignition system is of the battery and coil type feeding a six segment distributor, housing in its top portion two sets of contact breaker points operated by a three-lobe cam, and in its lower portion a centrifugal governor type automatic advance mechanism. The cam rotates in a clockwise direction (viewed from above) and operates the contact breakers alternatively at 60° intervals of cam rotation (120° crankshaft rotation).

Numbered from the front of the engine the firing order is 1-4-2-6-3-5.

On this type of distributor, the ignition timing of No.1 cylinder is carried out on one set of contacts, adjustment being effected by rotating the complete distributor body, and the timing of No.6 cylinder on the other set of contacts which are movable a few degrees round the cam centre to provide adjustment for slight variations in cam form and wear of fibre heels. If the engine will not run evenly at low speeds or detonation is experienced, it may be necessary to check the setting of the ignition timing.

The marking IGN-T.D.C is stamped on the flywheel and registers with a pointer when Nos.1 and 6 pistons are at T.D.C. The marking and the pointer are exposed by removing the small inspection cover from the N/S front face of the clutch housing.

Due to the fact that a friction damped spring drive is used for driving the valve gear and the distributor, and that the starting handle operates to turn the crankshaft through the medium of the spring drive, the starting handle must not be used for timing purposes. One rear wheel should be jacked up, top gear engaged and the engine turned by rotating the wheel in its normal direction of rotation.

A method of determining precisely when the contact points break, is to connect one lead of a 12 volt inspection lamp to the contact breaker terminal of the distributor and the other lead to the distributor body (earth), switch the ignition ON, turn the engine and as the points break contact, the light will come ON. An advantage of using this method is that the inspection lamp can be used to view the position of the flywheel timing marking.

The ignition is first set with No.1 piston at T.D.C. both valves closed and the distributor cam operating 'A' set of contacts.

Bulletin

MODEL: BENTLEY MARK VI

- 1 -

PROCEDURE FOR CHECKING IGNITION TIMING:

1. Locking screw ('A' set).
2. Locking screw ('B' set).
3. Adjusting screw ('A' set).
4. Adjusting screw ('B' set).
5. Locking screw (synchronising plate).
6. Locking screw (synchronising plate).
7. Adjusting screw (synchronising plate).

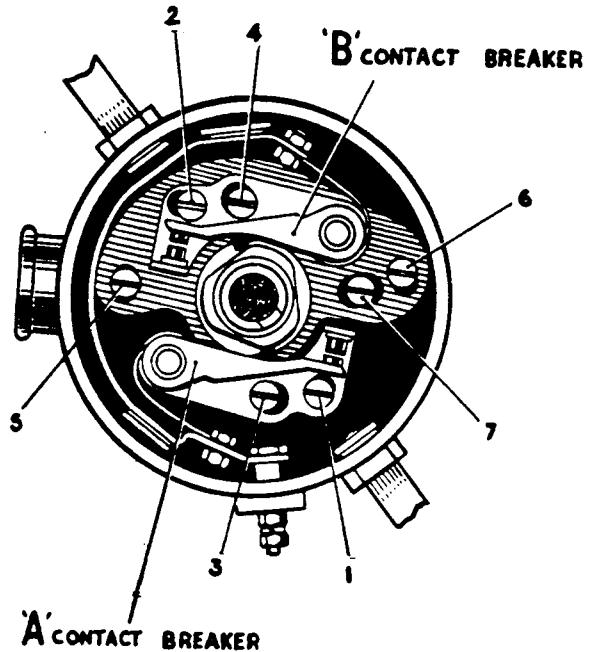

1. Remove the sparking plugs.
2. Jack up one rear wheel, engage top gear, release the hand brake and rotate rear wheel to turn the engine.
3. Remove the inspection cover from the clutch housing for viewing flywheel markings.
4. Set both contact breaker gaps at .019" - .021" using screws 3 and 4 for adjusting and screws 1 and 2 for locking the gaps when set.
5. Connect the leads of a 12 volt inspection lamp as described previously and switch the ignition ON.
6. Turn the engine in its normal direction of rotation until the distributor rotor approaches the No.1 cylinder firing position (approximately 11-o'clock on the distributor), continue to turn slowly until the points of 'A' contacts just break, as indicated by the bulb of the inspection lamp lighting up. Cease turning immediately this occurs and observe the position of the flywheel marking IGN.-T.D.C., which should register with the pointer if the timing is set correctly.
7. If the points break early, then turn the engine to line up the IGN.-T.D.C. marking with the pointer. If the points break late, then turn the engine backwards sufficiently to take up the backlash of the transmission and engine drives and then turn in the normal direction of rotation again to line up the IGN.-T.D.C. marking with the pointer.

Bulletin

MODEL: BENTLEY MARK VI

- 2 -

8. Slacken the screw of the distributor head clamp, and, holding the rotor in its fully retarded position, rotate the complete distributor body until the points of 'A' contacts just break. Tighten the screw of the distributor head clamp, taking great care not to overtighten to such an extent that the distributor drive bush is distorted.
9. Turn the engine through two revolutions and check the break of the points against the position of the flywheel marking. If necessary, re-adjust and re-check.

Having set the timing of No.1. cylinder on 'A' set of contacts, it will now be necessary to check the timing of No.6 cylinder controlled by 'B' contacts. This is carried out with No.6 piston at T.D.C. both valves closed.

10. Turn the engine so that No.6 piston is approaching T.D.C. and the distributor rotor approaching the firing position for that cylinder (approximately 5-o'clock); continue to turn slowly until the points of 'B' contacts just break, then observe the position of the flywheel marking IGN.-T.D.C.
11. If the points break early or late, then line up the flywheel marking with the pointer.
12. Slacken screws 5 and 6 and adjust the break of 'B' contact points by rotating the screw 7. Lock screws 5 and 6.
13. Turn the engine through two revolutions and check the break of 'B' contact points against the position of the flywheel marking. If necessary, re-adjust and re-check.
14. Switch the ignition OFF.

NOTE: If continued detonation is experienced due to the use of low octane fuels, it is permissible to set the ignition two or three degrees retarded ($5/16$ " to $3/8$ " on the flywheel). In such cases, the ignition should first be timed to its normal setting to ensure synchronisation of the contact breakers, the retarded setting then being effected by rotating the distributor body as described in Operation No.8.

MODIFICATION.CATEGORY 3A:WINDSCREEN WIPERS-ELIMINATION OF NOISE.

This Bulletin provides additional information to that contained in Bulletin BB-15, dealing with the elimination of noise from Berkshire screen wiper equipment. All the recommendations made in Bulletin BB-15 should still be effective in the event of noisy operation of these screen wipers, but should noise persist, the following notes will be of further assistance in its elimination.

The following information is not applicable to Bentley Cars fitted with Lucas screen wiper equipment.

1. The driving cables, especially the intermediate cable, have proved to be the source of most cases of noisy operation. Secondary causes are faults in the gearboxes and the motor and reduction gear.
2. All inner cables should have correct end clearance, otherwise, when the cable is bent, the end clearance will be taken up, causing tightness and noise after operating for a short time. Check the cable for end clearance and see that it can be easily rotated when bent to its operating shape. Normally an end clearance of .075" is necessary when the cable is straight.
3. If the end clearance is inadequate, it is permissible to remove the horseshoe retaining washer from one end of the inner cable. The amount of projection of the driving tongue at this free end under operating conditions should be between .500" and .650" to ensure correct engagement. A recommended procedure for checking this projection is as follows:

Connect the drive at the end fitted with the horseshoe washer. Bend the drive to its operating shape and hold the end face of the outer cable against the end face of the gear box union as shown in the diagram. The projection of the driving tongue should then be within the above limits.

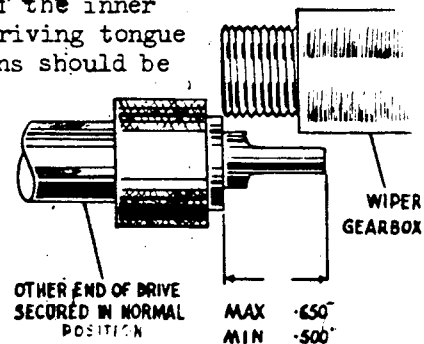

4. The cables should be well greased. This is not easy as the inner cable cannot be removed, but it is possible to force grease down the cable from each end using a grease gun and adaptor on the screwed end cap. Penetration of the grease down the cable will be assisted if the inner cable is worked backwards and forwards and rotated whilst operating the grease gun. The best lubricant for the purpose is a grease like Shell Retinax CD, made sufficiently fluid with the addition of a small quantity of engine oil. Avoid making the grease too fluid or forcing an excessive quantity of grease down the cables, otherwise, the grease will exude on to the trim under the capping rail.

Bulletin

MODEL : BENTLEY MARK VI

- 2, -

5. The overall length of the intermediate cable measured from collar to collar should not exceed 45.750". If it is appreciably longer than this, an unnecessarily severe bend in the cable is imposed.
6. Complaints of slow operation when cold are probably due to the use of unsuitable grease in the motor and gearboxes. Duckham's ZNOL KG.20 grease has been found to give good results under cold conditions, and should be used in the reduction gear on the motor.
7. Carry out all the other recommendations described in Service Bulletin BB-15. In particular, pay special attention to the insulation of the cables and gearboxes from the scuttle rail, using sorbo rubber or felt for insulation purposes.

INSTRUCTIONS FOR FITTING 7" SEALED BEAM UNITCONVERSION ASSEMBLY TO LUCAS RF770 HEADLAMPS.FOR INFORMATION:

In order to comply with American Lighting Regulations, it will be necessary to convert the standard headlamps on cars now in use in the U.S.A., to enable them to be fitted with a 7" Sealed Beam Unit. The conversion assembly unit can be obtained from Lucas Electrical Services (Inc.) 653, Tenth Avenue, New York 19, N.Y.

1. CONVERSION OF STANDARD HEADLAMPS:

To convert standard headlamps, proceed as follows:-

- (i) Remove the front rim by slackening the single securing screw.
- (ii) Slacken the screws in the flange of the Light Unit and turn the Light Unit in an anti-clockwise direction to detach the flange from the securing screws. The Light Unit can now be lifted out of the lamp body.
- (iii) Remove the back shell by twisting in an anti-clockwise direction and cut off the cables at the back shell.
- (iv) The Light Unit assembly and back shell can now be discarded.

2. FITTING CONVERSION ASSEMBLY:

- (i) Remove the plated unit rim from the seating flange by taking out the two horizontal adjustment screws.

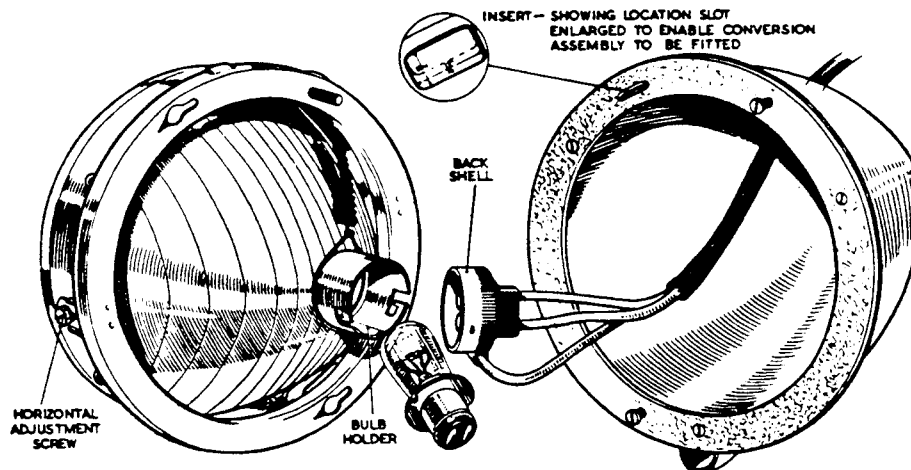

FIG. 1. STANDARD HEADLAMP WITH LIGHT UNIT REMOVED.

Bulletin

MODEL: BENTLEY MARK VI

- 2 -

- (ii) Withdraw the screws securing the Sealed Beam brackets from inside the unit and place the Sealed Beam unit in position. Finally place the brackets in position so that they fit over the locations on the Sealed Beam unit and secure by the fixing screws.
- (iii) Fit the seating flange to the unit rim by means of the two horizontal adjustment screws, taking care to locate the rim between the head and flange washer of the vertical adjustment screw.
- (iv) To fit the Sealed Beam conversion assembly to the body of the head-lamp, it will be necessary to open up the vertical adjustment screw location slot and cork washer to $13/16$ " wide by $7/16$ " deep, as shown in the "INSERT" Fig. 1.

3. WIRING:

Connection to the Sealed Beam unit is made by means of a three point adaptor plug. To make the connections, proceed as follows:-

- (i) Bare approximately $\frac{3}{8}$ " of the cables.
- (ii) Remove the adaptor from the Sealed Beam unit.
NOTE: It will be observed that the rear of the adaptor is marked "Ground", "Pass" and "Drive".
- (iii) Remove the three spring contacts from the adaptor.
- (iv) Solder the core of the black cable to one of the spring contacts and fit the contact in the recess of the adaptor marked "Ground".

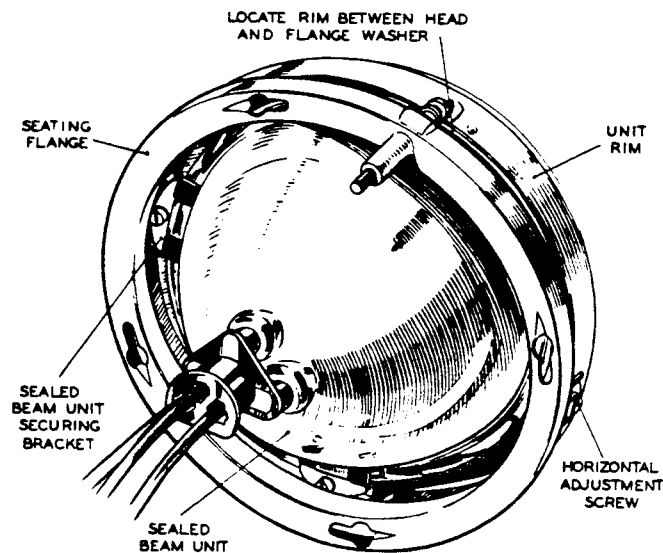

FIG. 2. CONVERSION ASSEMBLY FITTED.

ALL CORRECTIONS SHOULD BE ADDRESSED TO:
BENTLEY MOTORS (UK) LTD. SERVICE STATION, NYTHE ROAD, WILLETON, LONDON, W17 0EP

- 3 -

- (v) Solder the core of the pink cable to one of the remaining spring contacts and fit the contact in the recess of the adaptor marked "Pass".
- (vi) Solder the core of the white cable to the remaining spring contact and fit the contact in the recess of the adaptor marked "Drive".

Finally fit the Sealed Beam unit assembly to the lamp body as follows:-

Position the Sealed Beam unit so that the vertical adjustment screw locates in the location slot in the body of the lamp and the heads of the screws protrude through the holes in the flange of the Sealed Beam unit. Twist the unit in a clockwise direction and secure by tightening the screws. Before replacing the front rim, it will be necessary to set the lamps to comply with the American Lighting Regulations, details of which are given in the following paragraph.

4. SETTING AND ALIGNING (HEADLAMPS).

When setting the lamps, the measurements are to be made with no load on the car except the driver in the front seat.

The headlamps must be set so that the brightest area of the headlamp beams coincides with the vertical centre lines of the headlamps and a line drawn parallel on the screen 3" down from the horizontal centre

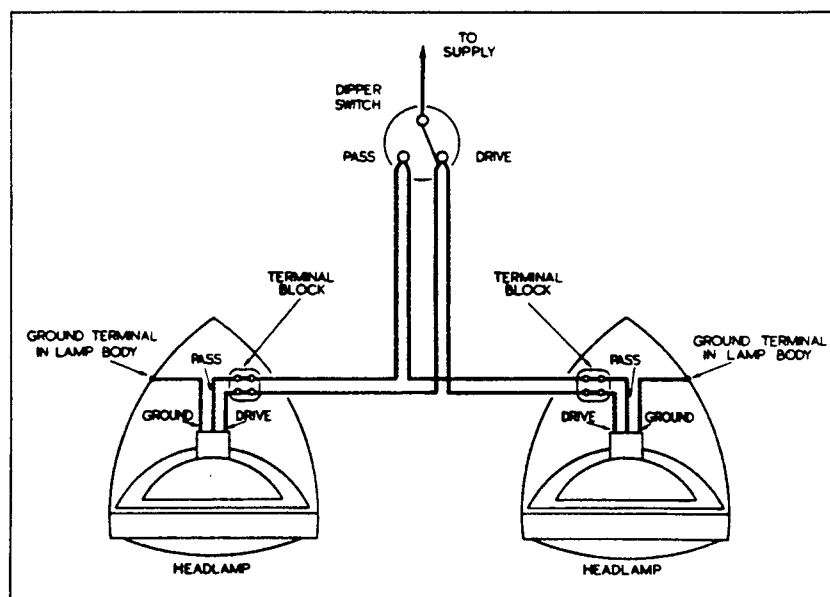

FIG. 3. CONNECTION DIAGRAM.

Bulletin

MODEL BENTLEY MARK VI

- 4 -

line of the headlamps from the ground (see Fig.4).

To make adjustment to the headlamps, proceed as follows:-

Remove the front rim by slackening the securing screw. Horizontal adjustment to the lamp is carried out by slackening the two screws provided, (one on each side of the lamp).

Vertical adjustment is made by means of the adjusting screw near the top of the lamp.

FOGLAMPS:

The foglamp must be set so that the beam centre is 12" from the centre line of the car, towards the nearside of the road; also the "cut off" of the beam must be set so that it is 3" below the horizontal centre line of the foglamp.

To make adjustment to the foglamp, slacken the single fixing nut at the base of the lamp, move the lamp to the required position, and finally tighten the fixing nut.

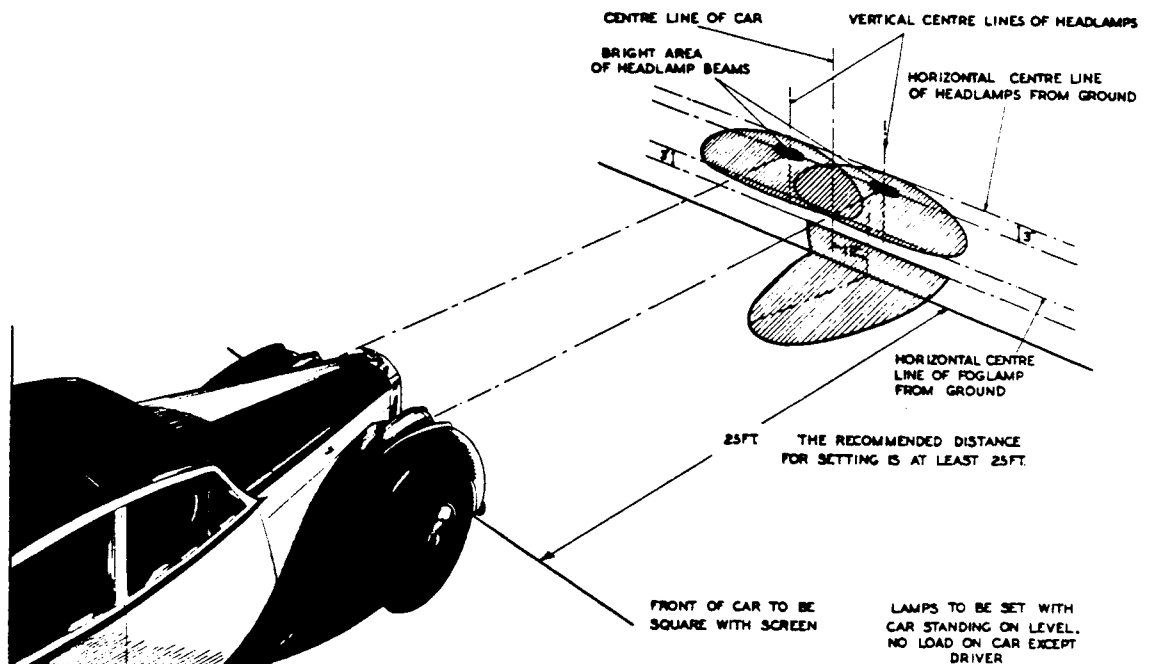

FIG. 4. HEADLAMP AND FOGLAMP SETTING DIAGRAM.

Bulletin

MODEL BENTLEY MARK VI

FOR INFORMATION:PASS LAMPS.

A regulation in effect from January 1949, in the United Kingdom, prohibits the use of a pass lamp, the centre of which is less than 24 inches from the ground. It refers only to a pass lamp which is used as a driving light and does not affect a lamp which is used only in conditions of fog or snow and is operated through a separate switch.

The average height of this lamp on the Bentley Mark VI is 22" and an alteration is therefore necessary, since the pass lamp is part of the standard dipping system. The alteration takes the form of a pedestal interposed between the base of the lamp and front apron as shown in the diagram. All necessary parts may be obtained from the London Service Depot on request.

FITTING INSTRUCTIONS.RAISED PASS LAMP.

1. Disconnect the pass lamp feed wire from the junction box on the right-hand wing valance, and thread the wire back as far as the lamp.

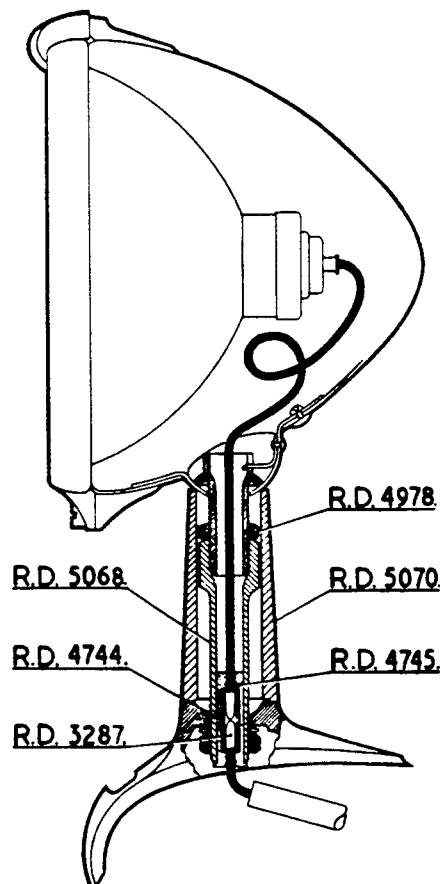

ALL COMMUNICATIONS SHOULD BE REFERRED TO:

BENTLEY MOTOR CARS LTD., 470, WYMS LANE, CREWE, ENGLAND

Bulletin

MODEL BENTLEY MARK VI

- 2 -

2. Remove the pass lamp.
3. Fit the extension locknut on to the pass lamp hollow bolt and screw on the internally threaded extension as far as it will go. Tighten down the locknut.
4. Cut the wire connected to the bulb adaptor so that it extends $1\frac{1}{2}$ " beyond the end of the extension. Remove the insulator for $\frac{1}{2}$ " and fit a terminal.
5. Fit the cylindrical metal connector into the rubber connector bush and press the terminal and wire into the unshouldered end.
6. Fit a terminal to one end of the wire supplied and push it into the connector. Do not cut the wire.
7. Pass the extension pedestal over the wire and on to the extension bolt. Thread the wire through the front apron motif and fit the pass lamp with the original "shake proof" washer and nut. Leave the nut slack for final focussing.
8. Connect the wire back to the wing valance junction box through the original waterproof covering and check the circuit, make sure that the wire will clear the starting handle.
9. Focus the lamp in accordance with the diagram on page 3.

The following material is required to carry out this work:-

<u>Part No:</u>	<u>Description:</u>	<u>Quantity:</u>
RD.4750	P.V.C. Single Core Cable.	6-Ft.
RD.5070	Centre lamp pedestal.	1-Off.
RD.5068	" " extension.	"
RD.4978	" " Locknut.	"
RD.4745	Connector bush (rubber)	"
RD.4744	Connector.	"
RD.3287	Terminal.	2-Off.

(Retail price of Material (8.12.48). £1. 0s. 8d.)
 (Approx. time $2\frac{1}{2}$ hours.)

Bulletin

MODEL BENTLEY MARK VI

- 3 -

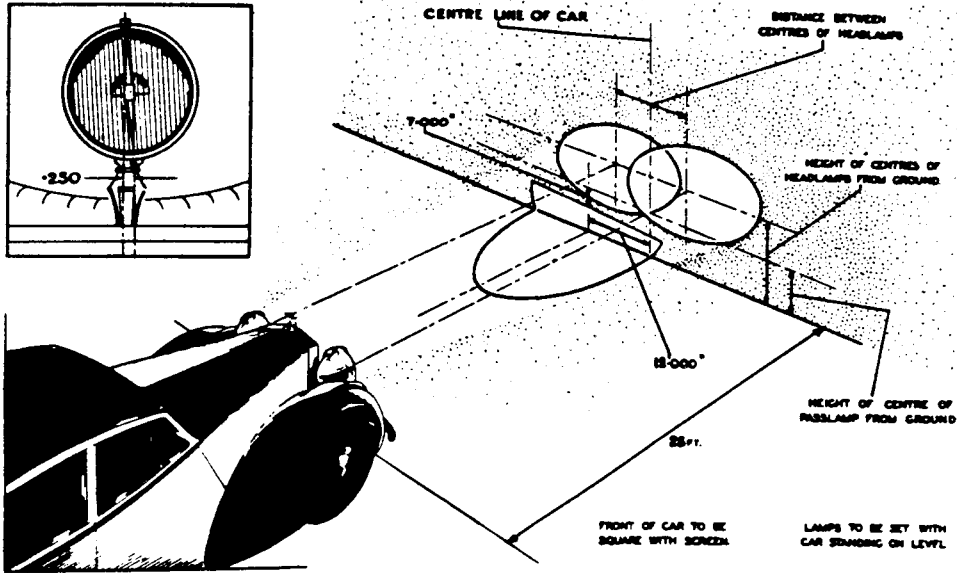

The settings and the measurements between ground level and lamp centres are to be made with the car loaded with five persons. The view inset shows the pass-lamp correctly tilted to correct for road camber.

ALL COMMUNICATIONS SHOULD BE ADDRESSED TO
 BENTLEY MOTORS (1931) LTD. PYM'S LANE, CREWE, ENGLAND

Bulletin

MODEL BENTLEY MARK VI

FOR INFORMATION:PASS LAMPS.

Please note that the original retaining nut supplied with the pass lamp has been replaced by a cap nut as a means of retaining the lamp connector in position in the base of the extension piece.

The part number of this new nut is RD-6109, and the existing pass lamp retaining nut should be discarded.

Please also amend, in the list of parts required, Part No: RD-4745 from "1 off" to "2 off".

Bulletin

MODEL BENTLEY MARK VI

FOR INFORMATION:REPLACEMENT OF THE 4½" LUCAS C45PV DYNAMO BY THE
5" LUCAS RA-5 DYNAMO

The output of the 4½" Lucas C45PV dynamo fitted to all Bentley chassis prior to B 380 CF, is adequate to meet all battery demands under normal conditions,

A state of persistent battery exhaustion may however, arise on a car which is primarily used for town work, where greater use is made of the starter motor and other electrical accessories and where the journeys are of extremely short duration.

In such cases it is recommended that the owner should be offered the 5" Lucas RA-5 dynamo as a chargeable improvement. This has a maximum output of 25/27 amperes compared with the 20/22 amperes of the existing 4½" dynamo.

It should be noted that when the RA-5 dynamo is fitted, a higher capacity voltage control regulator and ammeter will also be required, and owing to the additional weight of the larger dynamo, larger section bracket securing studs will be essential.

The parts required, together with prices, can be obtained from the London Service Depot.

PROCEDURE FOR FITTING THE RA-5 DYNAMO

1. Remove the existing dynamo, dynamo bracket and swivel arm.
2. Remove the existing dynamo bracket securing studs from the crankcase, (4 x ¼" B.S.F.)
3. Drill out and then tap the existing stud holes to 5/16" B.S.F. Fit the new studs supplied.
4. Bolt on the new dynamo bracket and fit the RA-5 dynamo, using the nuts and washers from the original dynamo holding bolts. Lock the bolt heads with the tab washers.
5. Fit the new swivel arm with the set in the forward position and adjust to the correct belt tension.
6. Replace the existing dynamo 'D' and 'F' to regulator 'D' and 'F' cables by the new cables supplied.
7. Remove the existing voltage control regulator and fit the new higher capacity regulator supplied.

Bulletin

MODEL : BENTLEY MARK VI

- 2 -

8. Remove the front of the instrument panel, remove the existing 20-0-20 amps ammeter and replace by the new 30-0-30 amps ammeter which is supplied. (In view of the close grouping of the other electrical accessories beneath the dashboard, the car radio will require to be removed to permit access to the back of the instrument board.)

The following "Parts Required" list is included as a means of guidance in checking whether the requisite spares necessary to effect this change are at hand:-

<u>PART NO:</u>	<u>DESIGNATION.</u>	<u>NUMBER REQUIRED:</u>
RD.3679	Dynamo, Lucas RA-5, (5")	1 Off
RE.5492	Bracket, Dynamo Assy.	1 Off
RE.6025	Swivel Arm Assy.	1 Off
RD.4073	Ammeter, 30-0-30 Amps.	1 Off
RD.4067	Pulley, Dynamo.	1 Off
RD.3277	Voltage Control Regulator.	1 Off
RD.4113	Cable, Dynamo 'D' to Regulator 'D'.	1 Off
RD.4115	Cable, Dynamo 'F' to Regulator 'F'.	1 Off
KB.400	Stud, Dynamo Bracket Securing 5/16" B.S.F.	4 Off
KB.8559	Bolt, Dynamo Securing.	2 Off
K.8807	Washer, Plain.	4 Off
KB.7107	Washer, Tab.	2 Off
K.4313	Nut 5/16" B.S.F.	4 Off
K.9009	Washer, Spring.	4 Off

Bulletin

MODEL BENTLEY MARK VI

HEADLAMPSALTERNATIVE DIPPING SYSTEM

An alternative dipping system is available as a chargeable improvement for those cars at present fitted with the pass lamp system.

The new arrangement consists of the normal "dip and switch" in which operation of the footswitch extinguishes the right-hand light and deflects the left-hand beam vertically downwards by virtue of the displaced filament in the double filament bulb. The reflector itself does not dip.

Both headlamps have double pole adaptors, but the right-hand lamp is fitted with a single pole prefocus bulb, the pole of which is wide enough to make contact with the live plunger in the double pole adaptor.

This arrangement has been adopted because it gives a very much improved illumination compared with two normal double filament bulbs in similar reflectors. Furthermore, the new reflectors themselves provide a better driving light than the original type and in addition when driving on the dipped beam, the range of illumination is a considerable improvement on the pass lamp, so that the change has less effect on visibility.

Wiring is arranged so that a simple conversion can be made to suit requirements in countries where the car is driven on the right, and double filament dipping with double filament bulbs in both headlights can also be provided by similar wiring alterations. The spare bulb supplied in the tool tray will be double pole, so that in the event of bulb failure in either lamp, the replacement will be suitable, although there will be a reduced intensity of illumination in the right-hand lamp.

All the necessary material can be obtained from the London Service Depot:-

Approximate time for conversion:- 8 hours.

FITTING INSTRUCTIONS.HEADLAMPS & WIRING:

(Letter identifications refer to wires similarly marked in the wiring diagram.)

1. Disconnect headlamps wires from both wing valance junction boxes and remove headlamps complete with wires and P.V.C. covering.
2. Fit the new reflectors supplied and connect up as shown in the wiring diagram (A,B,L,M,F & J). In the right-hand headlamp, the dipped filament feed wire is run into the junction box but is taped up without being connected (Wire 'A').
3. Disconnect wire 'C' at the distribution board end and connect to the dip terminal on the foot-switch. Withdraw the existing wire (D) which runs between the foot-switch dip terminal and distribution board.

ALL COMMUNICATIONS SHOULD BE ADDRESSED TO
BENTLEY MOTORS (1931) LTD., SERVICE STATION, HYTHE ROAD, WILLESDEN, LONDON, N.W.10

Bulletin

MODEL: BENTLEY MARK VI

- 2 -

4. Run a new wire 'E' from the right-hand wing valance junction box to the dip terminal on the foot-switch.

NOTE: Do not replace junction box covers, conduits etc. until completion of the pass lamp wiring.

PASS LAMP WIRING AND FITTING SWITCH TO FACIA BOARD:

1. Disconnect the existing wire 'P' from the distribution board and re-connect it to one of the vacant terminals in the 12-way junction box (F).
2. Remove the wooden facia panel as follows:-
 - (a) Remove the three countersunk screws along the top of the panel.
 - (b) Remove all push/pull switch knobs by unscrewing to the left. The rheostat switch knob is secured with a grub screw.
 - (c) The facia board itself is secured by five screws of which three are along the top. Along the lower edge there are two screws countersunk into the wood. On early models, these are removed in the normal way, but on later models, they should be turned to the right to release the panel retaining clips at the back. The screws should be tested carefully to see which type is fitted. Those which should be turned to the right to release, are countersunk about one inch into the wood. The alternative type is considerably shallower.
3. Remove the Radio Set as follows:-
 - (a) Disconnect aerial.
 - (b) Disconnect power feed.
 - (c) Disconnect bonding tape if fitted.
 - (d) Remove set bolts holding the radio set.
4. Fit the switch supplied into the vacant hole in the top of the instrument panel above the switch box. If this hole does not already exist, drill as shown in Fig.1.

- 3 -

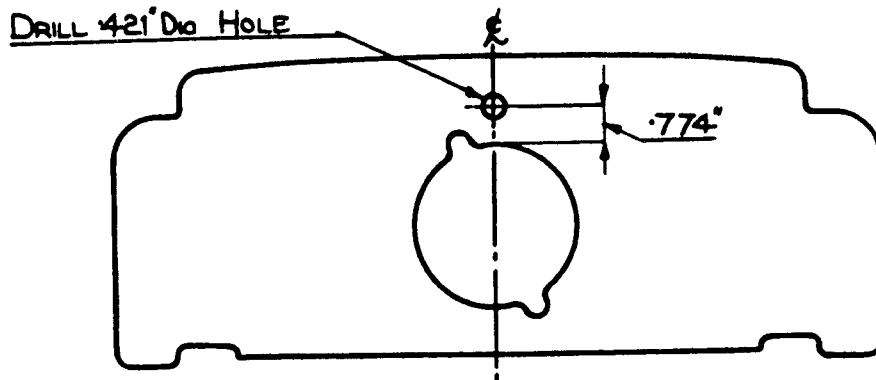

FIG. 1.

5. Drill the wooden fascia panel as shown in Fig. 2.

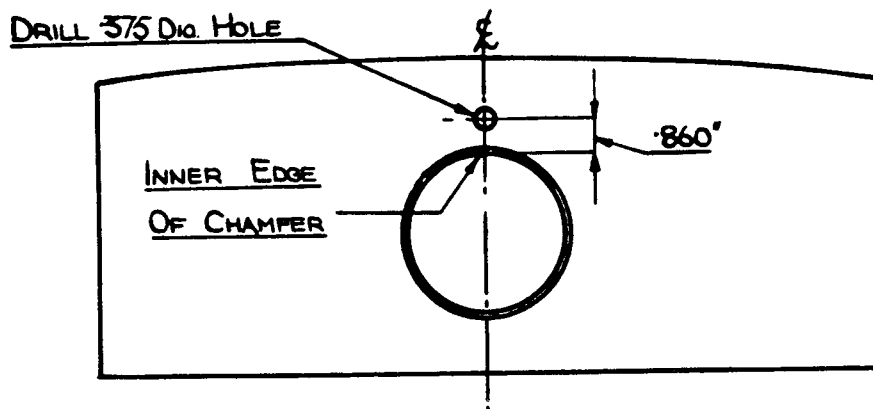

FIG. 2.

6. Run wires G & H as in the diagram and bridge the top of the side and tail light fuse to the original pass lamp fuse using RD-3096.

NOTE: All new wires should be run through existing conduits.

7. Test headlight and pass light circuit and replace all parts which have been removed.
8. Align lamps as shown in Fig. 3.

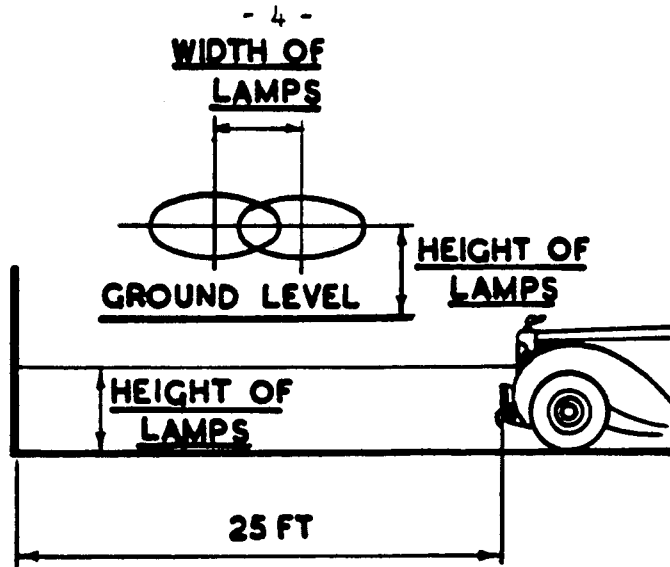

FIG. 3

CONVERSION FOR DIPPING THE RIGHT-HAND LIGHT:

1. The wire marked (A) in the diagram should be connected to the dipped filament feed terminal in the right-hand wing valance junction box.
2. Reverse the headlamp bulbs
3. Disconnect wire (P) and tape up.

CONVERSION TO DOUBLE DIPPING:

1. Connect the wire marked (A)
2. Replace the single filament bulb in the right-hand headlamp with a double filament type.

List of Parts Required for Dip and Switch Conversion:

<u>Description:</u>	<u>Quantity:</u>	<u>Part No:</u>
Switch (PS 7)	1	RD-6101
Reflector units	2	RD-4544
Bulb S/P S/F 48w	1	RF-4516
Bulb D/P D/F 48w/48w	2 (one spare)	RD-4561
Connecting link	1	RD-3096
3 core cable	2 (24")	RD-4647
Cable, foot-switch to R.H. junction box.	1 (6/50" Pink)	RD-4556
Cable, Pass lamp switch to 12 way junction box	1 (39 00" Black)	RD-4553
Cable, distribution board to Pass Lamp switch.	1 (49 00" Green)	RD-4555

Bulletin

MODEL: BENTLEY MARK VI

- 5 -

WIRING DIAGRAM

All Chassis Nos:
to B-193 DZ.

Conversion to dip and switch
from Pass Lamp system

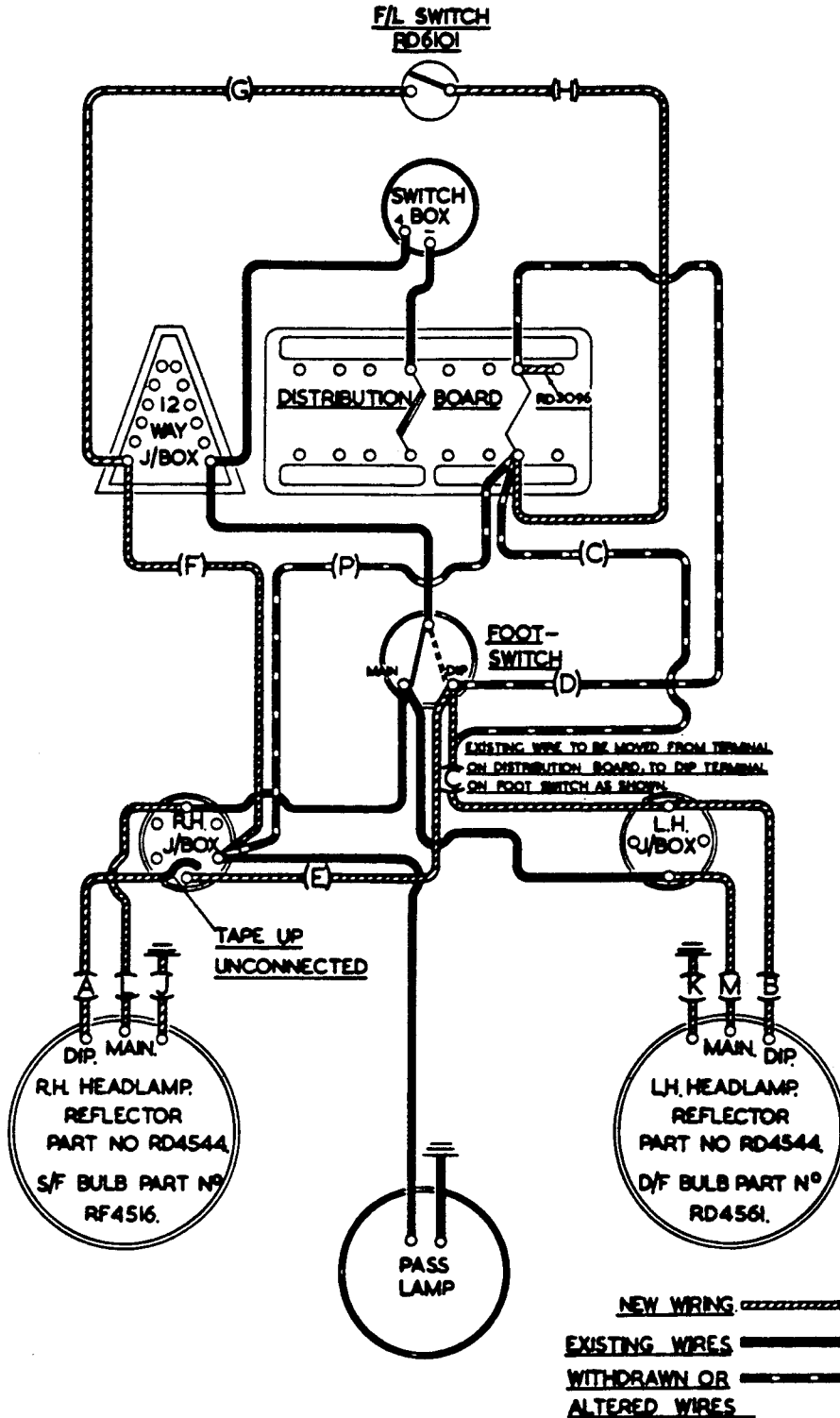

ALL COMMUNICATION SHOULD BE ADDRESSED TO
BENTLEY MOTORS (1931) LTD. SERVICE STATION, HYTHE ROAD, WILLESDEN, LONDON, N.W.1

SB/LT.10/SP. 6.4.49.

PRINTED IN ENGLAND

SECTION
P

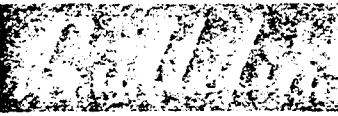

MODEL BENTLEY Mk. VI

FOR INFORMATION.AMENDMENT TO SERVICE BULLETIN BB-67

Subsequent to the publication of Service Bulletin BB-67, certain of the parts required for the conversion of the pass lamp system incorporated in earlier Bentley Mk. VI chassis to the dip and switch headlamp system introduced on current chassis have been allotted fresh piece numbers.

In addition, a complete conversion set comprising reflector and bulbs has been introduced, thus making it unnecessary to order the component parts separately as originally stated.

Will Retailers, therefore, please amend page 4 of their existing copies of this Bulletin to read as follows:-

<u>Description.</u>	<u>Quantity.</u>	<u>Piece No.</u>
Switch (PS.7)	1 off	RD-3450
Reflector Unit (Conversion Set c/w Bulbs)	2 off	RE-10668
Cable, Headlamp, 3-core	2 off (27")	RD-4996
Connecting Link	1 off	RD-3096
Cable, Foot-Switch to R.H. Junction Box.	1 off (67.50" Pink)	RD-4556
Cable, Pass Lamp Switch to 12-way Junction Box.	1 off (39.00" Black)	RD-4553
Cable. Distribution Board to Pass Lamp Switch.	1 off (49.00" Green)	RD-4555

FOR INFORMATION.PETROL PUMP TESTING SWITCH.

This Service Bulletin supersedes Bulletin No. BB-68 (Section P) dated 12.5.49. reference SB/GM.1/SF, which should be destroyed.

All cars in the Bentley range are fitted with tandem petrol pumps controlled by the ignition switch to operate simultaneously when the ignition is switched on.

Many owners have expressed a preference for the three-way switch system, to which they have become accustomed as owners of pre-war Bentley cars. This allows separate operation of each pump in order that a periodic check can be made to ensure that both pumps are working satisfactorily. A three-way switch is now specified for this purpose and may be offered to owners as a chargeable improvement.

The following illustration shows the switch fitted to the facia.

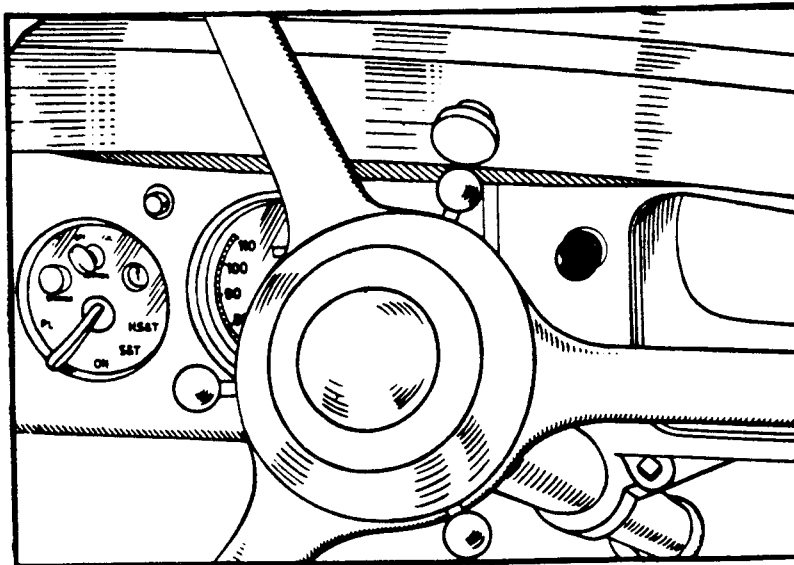

The switch position shown above is recommended to conform with the facia layout of the Bentley Mark VI. Standard Saloon. Should the

- 2 -

recommended position be impracticable, the location is left to the discretion of the Retailer.

The part numbers of the switch assembly, and instructions for fitting and wiring are as follows.

FITTING AND WIRING INSTRUCTIONS.

NOTE: Prior to marking off and drilling the facia, it is recommended that a check be made to ascertain whether any fittings have been positioned on the rear face of the panel, in the vicinity of the proposed location of the switch.

Providing that no such fittings have been added, proceed as follows:-

1. Mark off and drill the facia panel to the dimensions given in Fig.1.
2. Connect bridge piece (RH.303) between terminals 2 and 4 as shown in Fig.2.
3. As it is impracticable to supply a mounting bracket to suit a variety of mounting positions it is left to the discretion of the Retailer as to what method he uses to secure the switch.

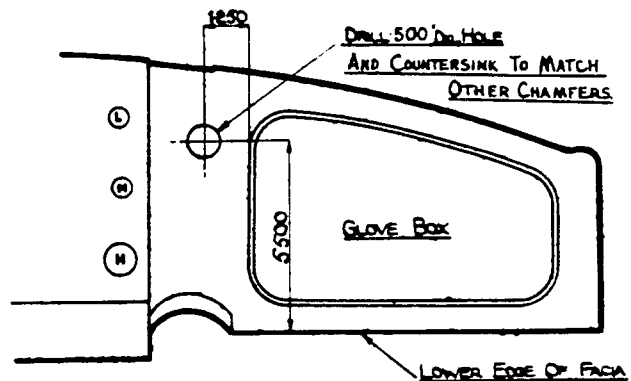

FIG.1. DRILLING INSTRUCTIONS FOR FACIA PANEL.

NOTE: It is pointed out that the flat on the switch shank should be in the upper-most position, to ensure that the "A & B" engraving is vertical in the switch central position. If it is impossible to mount the switch in this way, the location hole in the knob must be re-drilled in order to bring the knob back to the correct position.

4. Connect the positive side of Demister Switch to the main feed of the petrol pump switch (See Fig.2.)

- 3 -

5. Run two wires from the petrol pump switch through the metal cable conduit to the existing twelve-way junction box located immediately above the fuse box. Connect these two wires to vacant terminals.

NOTE: Should the twelve terminals in the junction box be already in use, an additional junction box will be required. Instructions covering the fitting and wiring of the additional junction box are given later in this leaflet.

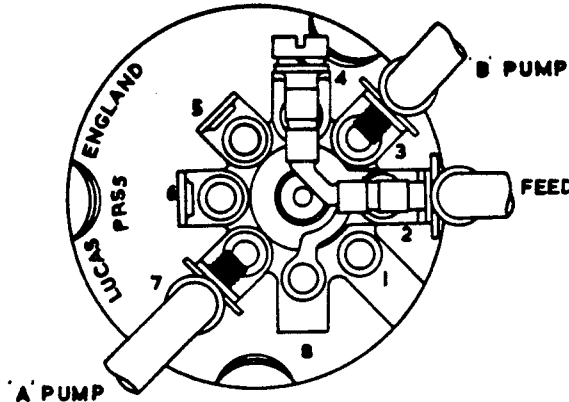

FIG.2. WIRING DIAGRAM FOR PETROL PUMP SWITCH.

6. Remove and discard the short length of wire fitted between the rear and front petrol pump terminals, and then disconnect the cable running from the pumps to the fuse box. Connect a length (6' 6") of new cable to each of the pump terminals, and then feed these cables through metal conduit up to the twelve-way junction box. Wire the pumps to the two terminals carrying the petrol switch connections, ensuring that the forward pump is wired to the terminal corresponding to 'A' on the pump switch and the rear pump to the 'B' terminal as shown in Fig.2.

ADDITIONAL JUNCTION BOX

FITTING AND WIRING INSTRUCTIONS

As previously mentioned in NOTE under operation No.5. the fitting of an additional junction box will be necessary in the event of the existing twelve-way junction box being fully wired up.

Proceed as follows:-

1. Mark off and drill two 0.191" dia., i.e. 2 BA clearance, holes through the dash for the junction box retaining screws as shown in Fig.3.
2. Fit the junction box as shown, securing this in position by means of the two 2 BA x 1/2" long Cheesehead setscrews supplied.

- 4 -

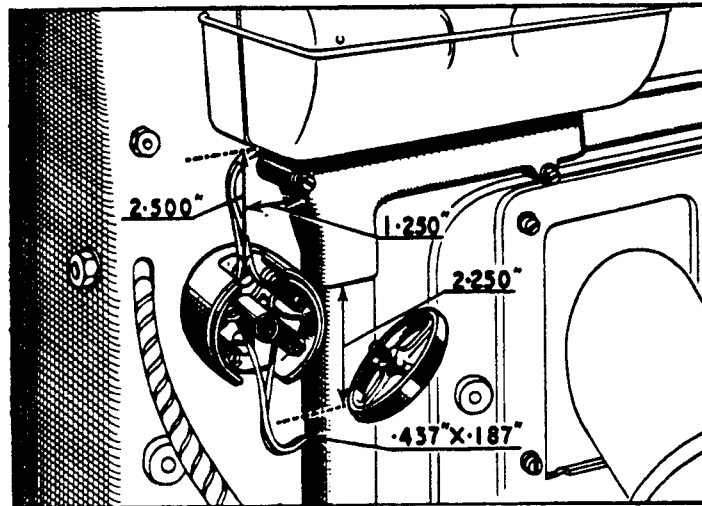

FIG.3. DRILLING AND FIXING - JUNCTION BOX.

3. Feed the two leads from the petrol pump switch through the conduit and below the fuse box, and connect up to two of the terminals in the additional junction box.
4. Cut an aperture $7/16'' \times 3/16''$ in the side of the conduit, and draw the two leads from the petrol pump terminals through this up to the junction box. Connect lead from the forward pump to the terminal carrying the "A" connection, and the rear pump lead to the terminal carrying the "B" connection from the petrol switch. Replace the junction box cover.

MATERIAL REQUIRED.

The following lists of parts cover all requirements, list "A" being the material needed when the existing twelve-way junction box is used, and list "B" the extra material required when fitting the additional junction box.

Bulletin

MODEL BENTLEY MARK VI

- 5 -

A	<u>DESCRIPTION.</u>	<u>PART NO.</u>	<u>QUANTITY.</u>
	Switch for Petrol Pumps (Lucas)	RD.6710	1
	Knob for Petrol Pump Switch	RH.194	1
	Bridge Piece	RH.303	1
	+Cable 16/012 P.V.C., Single Core	310/3267	18' 6"
	Cables Eyes, (Petrol Pumps)	RD.3346	2
	Cable Eyes, (Switches)	RD.3690	4
	Sleeve, Cable Eyes	RD.7589	4
	Label, Instruction	RH.309	1

NOTES: Item marked + should be cut to the following dimensions and used as stated:-

- 1 off length x 6" : Petrol pump switch to demister switch terminals.
- x2 off lengths x 2' 6" : Petrol pump switch to junction box.
- 2 off lengths x 6' 6" : Petrol pumps to junction box.

Two cable eyes to be fitted to the 6" cable ONLY.

B.	<u>DESCRIPTION.</u>	<u>PART NO.</u>	<u>QUANTITY.</u>
	Junction Box, Four-way	RD.3085	1 off
	Setscrews, 2 BA x 1/2" long, Cheesehead	K. 1910	2 off
	Nuts, 2 BA.	K. 4006	2 off
	Spring Washers, 2 BA.	K. 9006	2 off

When fitting the above mentioned junction box, an additional 9" should be allowed to each of the two cable lengths marked x under list "A", thus increasing the total required to 20' 0".

PETROL PUMP TESTING SWITCH.

When this extra switch is fitted, Instruction Leaflet SB/1a/50 should be inserted in the Customers Handbook.

These leaflets are available, and can be obtained from the Main Service Station, Hythe Road, Willesden, N.W.10. on request.

MODIFICATION TO ISOLATE LUCAS WINDSCREEN WIPER**MOTOR SWITCH WHERE FAILURE OCCURS IN SERVICE.****FOR INFORMATION:**

As the wiring circuit of the Lucas Windscreen Wiper on the Bentley Mark VI employs the use of two switches, one on the instrument panel and one in the manual control of the wiper arms, it is suggested that where failure of the manual control switch occurs, this may be isolated, leaving only the instrument panel switch in operation.

PROCEDURE:

To the earth terminal of the windscreen wiper motor, fit an additional cable, about 6" long. Fit a 310/3598 .250^o diameter Ross Courtney terminal to the other end of the cable and earth same by securing under one of the four retaining studs of the wiper motor support bracket.

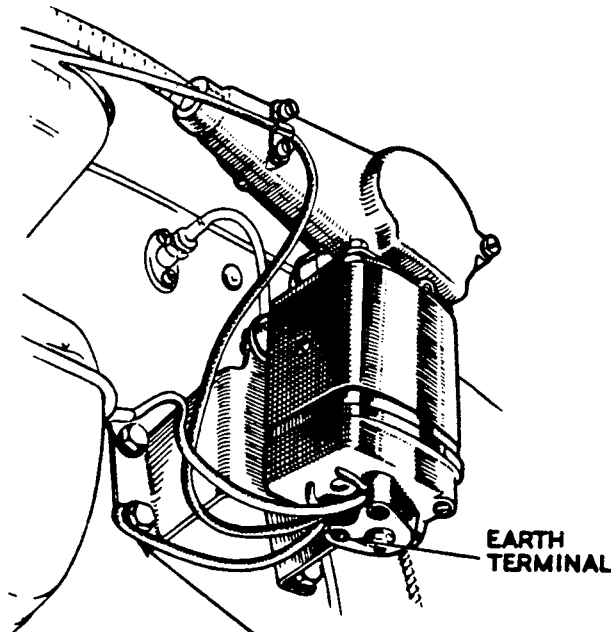

**FITTED WITH ROSS COURTNEY
TERMINAL & SECURED UNDER
RETAINING STUD**

This modification will isolate the switch on the manual control of the wiper arms, but will not alter the procedure for operating the wipers, it still being necessary to lift the wiper arms by means of the large knob on the facia and to close the windscreen wiper switch on the instrument panel.

Retailers are requested to advise this Service Station of the chassis numbers of 11 cars on which this modification is carried out.

MATERIALS REQUIRED.

310/3598 .250^o diameter R.C. Terminal.

1 Off

Suitable Cable about 6" long.

FOR INFORMATION:**REPLACEMENT HORN RELAY UNITS.**

Retailers are advised that the Lucas C585K horn relay unit (Part No. RD-3084) as at present fitted, has been superseded by the Lucas SB-40 type unit (Part No. RD-6351), and that this is now the only replacement available.

Fig. 1 illustrates the general arrangement of the new assembly when installed on a car.

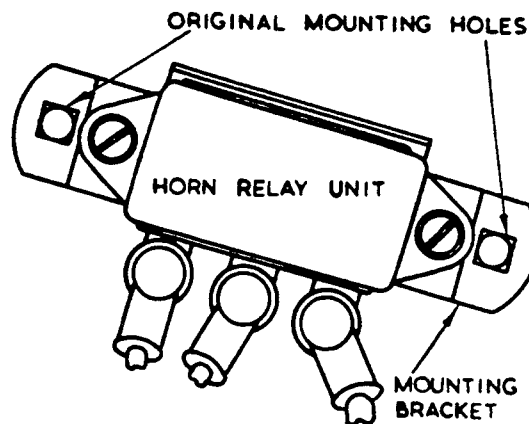

FIG. 1.

FITTING PROCEDURE.

NOTE: Due to the new replacement unit being smaller than the original type, a mounting bracket is included in order that the existing mounting holes in the valance plate may be used.

- 1) Remove the cover and disconnect the cable assemblies from the existing horn relay unit. Remove the relay unit from the valance plate.
- 2) Fit the new mounting bracket (RD-6352) to the valance plate, using the two shorter 2BA bolts supplied. Mount the replacement relay unit on to the bracket using the two 2BA cheesehead screws supplied.
- 3) Reconnect the cable assemblies to their respective terminals on the new relay unit.

MATERIAL REQUIRED.

RD-6351	Horn Relay Unit - Lucas SB.40	1 Off.
RD-6352	Mounting Bracket - Horn Relay to Valance Plate.	1 "
K. 101/2	Bolt, 2BA - Mounting Bracket to Valance Plate.	2 "
K.9006/2	Spring Washer, for above.	2 "
K.4307/2	Nut, 2BA for above.	2 "
K.1901/2	Screw Ch. Hd. 2BA - Horn Relay to Bracket.	2 "
K.9006/2	Spring washer for above.	2 "

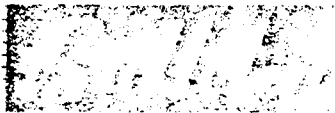

FOR INFORMATION:

ALTERNATIVE SPARKING PLUGS.

Will Retailers please note that the K.L.G. Type FE.60, 14 m/m non-detachable sparking plug has now been approved as an alternative fitting for all Bentley Mk.VI engines.

The amended list of recommended alternative sparking plugs should read as follows:-

Champion Type N.8.)	
K.L.G. Type FE.60.)	14 m/m non-detachable.
Lodge Type CLN.)	

The existing instructions covering plug servicing remain unaltered.



Bulletin

MODEL: BENTLEY MARK VI

FOR INFORMATION:FITTING OF REPLACEMENT AERIAL LEAD-IN.(BENTLEY MK.VI STANDARD SALOON)

The following information covers the procedure to be adopted should it be necessary to fit a replacement aerial lead-in on a Bentley Mk.VI Standard Steel Saloon in service.

P R O C E D U R E.

1. Remove the driving mirror, roof aerial, sun visors, windscreen wiper control knobs and trafficator switch lever.
2. Remove the scuttle rail trim (or panel, if fitted) from below the windscreen finisher.
3. Remove the two 1/4" B.S.F. nuts and washers retaining the grab-handle on the L.H. side of the scuttle rail, and withdraw the handle. Remove the single 1/4" B.S.F. nut and washer securing the R.H. side of the scuttle rail, also the eight chrome screws holding the windscreen finisher in position, and carefully withdraw the finisher, freeing the top edge first.
4. Slide back the sunshine roof and remove the screws from the three brackets retaining the front of the sunshine roof aperture finisher in position. Lift the front of the finisher sufficiently to expose the tacks holding the header fabric in position, and then remove these for the width of the finisher.
5. Unscrew the rear blind slider mounting above the R.H. front door and allow it to hang loose.
6. Using a thin-bladed screwdriver, lever up the fabric covered fillet above each of the front doors as far back as the centre door pillars. Remove the tacks from the sides of the header lining fabric and fabric covered rubber draught excluder to a distance of eight inches back from the top of the windscreen.
7. Starting from the front, gently pull the header lining free from the curved plywood, or hardboard fillet which it covers until the complete fillet is exposed. Remove the counter sunk metal thread screws which secure the upper and lower edges of this fillet, (these will be found to have their heads covered with a hard brown compound which can readily be removed with a fairly sharp thin-bladed screwdriver), remove the pins, if fitted, securing the upper side of the fillet, and then the fillet.
8. Remove the rubber hose connection situated at the top corner of the junction between the windscreen frame and R.H. screen pillar. Remove the R.H. inner scuttle trim pad, also any clips which may be found securing the aerial connector lead and disconnect the faulty lead from the radio and aerial contact block respectively.

ALL COMMUNICATIONS SHOULD BE ADDRESSED TO
BENTLEY MOTORS (1931) LTD., 27M'S LANE, CREWE, ENGLAND



MODEL: BENTLEY MARK VI

- 2 -

NOTE: If the replacement lead-in has a right angle plug at its radio end, a length of copper wire should be secured to the aerial end of the lead which is being withdrawn.

9. Remove the existing lead-in by gently withdrawing it from the BOTTOM of the R.H. screen pillar. It is of the utmost importance that no force is used during this operation, otherwise the lead may jam between the walls of the pillar and the drain tube, becoming impossible to free. In the event of any seizure becoming apparent, the lead should immediately be freed by pushing it back, at the same time twisting it.

10. Fit the replacement lead-in as follows:-

- a) If the plug-jack at the radio end of the new lead is of the straight type, connect the lead to the aerial contact block on top of the screen pillar, and then feed the other end of the lead carefully DOWN the pillar, (withdrawing it slightly and twisting it whenever any stricture becomes apparent) until a sufficient length has been passed down to enable it to be pulled through from below the pillar. Connect up to the radio and test out.
- b) If the plug jack at the radio end of the new lead is of the right-angle type, connect this to the radio, attach the other end of the lead to the lower end of the copper wire which has been drawn through the pillar, and feed the lead carefully UP the pillar, withdrawing it slightly and twisting it whenever any stricture becomes apparent. When the aerial jack appears at the top of the pillar, connect up to the aerial contact block. and test out.

NOTE: To ensure good contact, it is recommended that the aerial block contacts are raised slightly prior to connecting the replacement lead.

11. Refit the lead securing clips, rubber hose connection and header panel fillet (the screw heads should be covered again, using either plastic wood or cellulose stopper for the purpose). Refit the header fabric, using Dunlop upholstery solution or some similar rubber based adhesive. Refit the rubber draught excluders, side trim pads and rear blind catch mounting. Refit the windscreen finisher, and if fitted, the leather covered trim pads, (this may be somewhat facilitated by the use of soap as a lubricant on the trim pads. Refit the screen wiper control knobs, trafficator switch lever, driving mirror, aerial, sun visors and scuttle rail trim.

ALL CORRESPONDENCE SHOULD BE ADDRESSED TO
BENTLEY MOTORS (1951) LTD., PYMS LANE, CREWE, ENGLAND

FOR INFORMATION:REPLACEMENT IGNITION CONDENSERS

The ignition condenser (Delco-Remy Type DRH.1386, Part No. RD.6258) hitherto fitted on all chassis in production has been superseded by the improved DRH.8859 type unit, which is now the only replacement available.

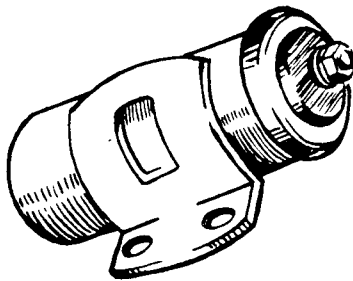

FIG. 1. DRH.1386 CONDENSER
(Original Fitting)

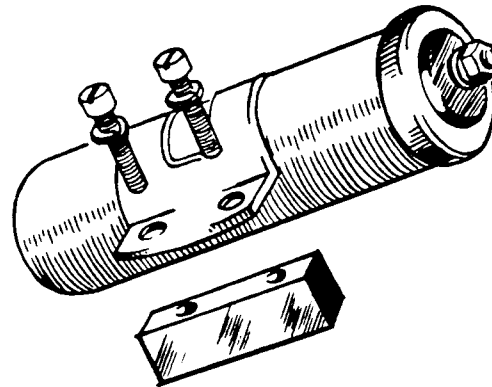

FIG. 2. DRH.8859 CONDENSER
(Current Replacement)

Although the new type condenser is interchangeable and is fitted on the distributor in a similar manner to the original unit, it will be observed from the above illustrations that a distance piece is also included. This is due to the difference in the relative angular setting of the mounting bracket.

The piece number for the new assembly is R.4481, and the kit includes the distance piece, longer setscrews, spring washers and connecting strip.

Bulletin

MODEL: BENTLEY MARK VI

FOR INFORMATIONREAR WINDOW DEMISTER

The Bentley 'R' Type is fitted with an electric demister incorporated in the rear window glass and controlled by a push pull switch marked RW on the facia. Rear windows of this type are now available for fitting to earlier models as a chargeable improvement at an owners request and this Bulletin set outs details of the fitting and wiring procedure.

FITTING INSTRUCTIONS.

- (i) Remove the screws securing the wooden finisher on the inside of the rear window and remove the finisher. Remove the glass by pressing it inwards from the outside.
- (ii) Fit the new rubber seal to the new glass ensuring that the terminal leads from the internal wiring are on the inside. The leads are fragile and should be handled carefully. After fitting the rubber seal, stick the leads to the inside of the glass with a protective covering of cellulose tape until the glass is finally fitted.
- (iii) Press the new glass evenly into position; do not fit the bottom edge first so causing the top to be forced into position. Fit squarely, using small levers between the glass and the body if necessary. Refit the finisher, loosely fitting the securing screws along the bottom, then along the top and sides. Tighten the screws sufficiently to press the rubber seal against the body. From outside the car, ease the rubber seal over the lip of the window aperture with a blunt chisel or screwdriver. Fully tighten the finisher retaining screws.
- (iv) Owing to possible variations in the curvatures of the glass and the body, additional packing may be required to ensure a sound seal. Raise the outside edge of the rubber seal and check whether the glass is fitting snugly; if not, remove the glass and pack the inside edge of the body, where necessary, with strips of Prestick. Refit the glass.

WIRING INSTRUCTIONS.

The recommended position for the RW switch is on the centre line of the facia about $\frac{3}{4}$ " above the master switch, where an existing hole in the steel instrument panel, behind the facia, may be utilised (Fig.1).

On some early chassis this position is used for the pass lamp switch and the new RW switch should be mounted on the wooden facia board to the right as shown in Fig.1. An additional mounting bracket and connections are necessary as shown under MATERIAL REQUIRED.

Bulletin

MODEL: BENTLEY MARK VI

- 2 -

- (i) Remove the wooden facia panel as follows:-
- (a) Remove the three countersunk screws along the top of the panel.
 - (b) Remove all push-pull switch knobs by unscrewing to the left. The heater rheostat switch is secured by a grub screw, and on later chassis, where the three position heater switch is fitted, by a spring loaded catch which must be depressed before pulling off the knob.
 - (c) Remove the two countersunk screws along the lower edge of the facia. On later models these screws should be turned to the right to release the panel retaining clips at the back. The later type are countersunk about one inch into the wood. The countersinking of the earlier type is considerably shallower.
- (ii) Remove the Radio Set as follows:-
- (a) Disconnect the aerial plug and the power feed.
 - (b) Disconnect the bonding tape, if fitted.
 - (c) Remove the four set screws retaining the set to its mounting bracket.

On later series the loud speaker is a separate unit and is mounted on a baffle plate alongside the steering column. The baffle plate is secured to a bracket on the column and an angle bracket on the floor and should be removed. The lead to the speaker is plugged into the top of the power unit.

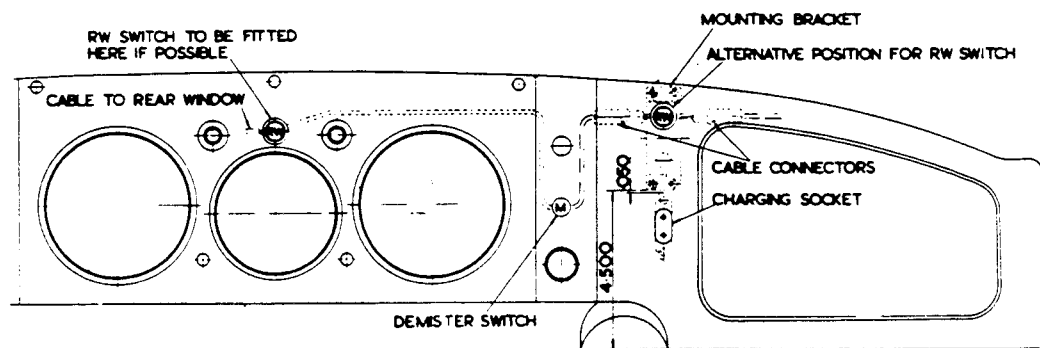

FIG. 1.

- (iii) Fit the RW switch to the centre vacant hole in the instrument panel or fit the bracket and switch to the right as shown in Fig. 1.

Bulletin

MODEL: BENTLEY MARK VI

- 3 -

- (iv) Connect a cable from the RW switch to the live side of the demister switch M. Lead the cable from the RW switch through the main wiring harness, where a suitable hole can be made in the P.V.C. tubing, through the dashboard and under the wiring harness conduit below the distribution board. From there the wire should follow the main loom, in a separate P.V.C. tube down the face of the dash, and on as far as the rear wheel arch, being strapped to the loom at regular intervals.
- (v) Drill a $\frac{1}{4}$ " (6.3 mm) hole through the petrol filter shield and lead the wire up through the box casing at the front of the spare wheel compartment and through the existing $\frac{1}{4}$ " hole in the top of the casing near the off-side wheel arch. Follow the angle of the boot wall and body and pass the wire into the boot through a $\frac{1}{4}$ " dia. hole drilled in the floor where the squab and body meet.

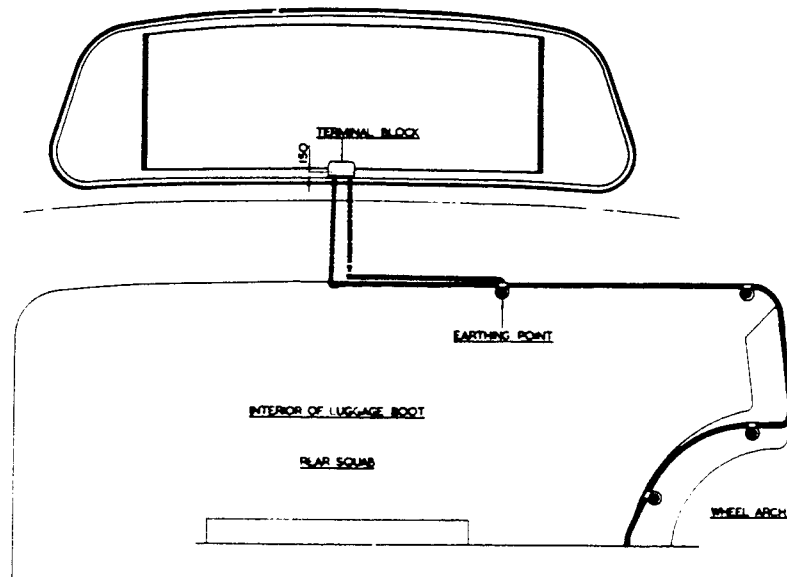

FIG. 2

- (vi) Anchor the cable to the squab screws following the line of the boot as shown in Fig. 2 and enclosing the cable in P.V.C. tube.
- (vii) Drill two $.218$ " dia. (5.5 mm) holes one on each side of the centre line, 1" between centres, through the rearmost sloping portion of the parcel shelf. Stick the terminal block to the rear window with Durafix symmetrically across the centre line and approximately $.150$ " (3.01 mm) above the top edge of the wooden finisher. When secure attach the demister terminals and the feed wire. Connect a short earthing cable from the terminal block to the centre screw on the top of the rear squab (Fig. 2).

Bulletin

MODEL: BENTLEY MARK VI

- 4 -

(viii) Drill a .324" (8.23 mm) dia. hole in the wooden facia to take the RW switch knob and refit the facia.

(ix) Refit the wireless.

MATERIAL REQUIRED:

		<u>No. off</u>
RF.7413	Rear-window Demister Glass	1
RB.6160	Seal Strip - Rear-window	1
RB.5927	Terminal Block Assembly	1
RB.7415	Terminal Cover - Terminal Block	1
RB.7416	Screw - Terminal Cover	1
K.4301/2	Nuts - Terminal Block	2
K.9003/2	Washer - Terminal Block	2
RD.3406	Cable Eye 5BA - Terminal Block	2
R.4815	R.C. Terminal No.11 - Cable Fixing	5
330/2890	Clip - Cable to Boot	1
F.59140	Strap - Cable to Main Loom	12
RD.6636	Switch RW - Push Pull	1
310/3267	Cable - Switch to Rear-window	25 ft.
	P.V.C. Tube 5 mm	10 ft.
	Durafix - Terminal block to window	As required.
A. RD.6633	Bracket - Switch to Facia Board	1
A. RD.4524	Screw - Bracket to Facia Board	2
A. RD.5745	Benjamin Type Connector - Male	2
A. RD.5746	Benjamin Type Connector - Female	2
A.	Only required when RW switch is fitted on side of Facia Board.	

These parts are available on request from the London Service Station.

Bulletin

MODEL BENTLEY MARK VI

FOR INFORMATION:SPARKING PLUGSTHE BENTLEY CONTINENTAL SPORTS SALOON

As a result of tests carried out on the Bentley Continental engine it has been decided to increase the heat range of the sparking plugs.

In future, all replacement plugs fitted should be Champion NA8 and not Champion N8 as at present specified.

Bulletin

MODEL: BENTLEY MARK VI

FOR INFORMATION:SMITH'S AUTOMATIC CIGAR LIGHTER

In the event of the failure of the cigar lighter element, it should be noted that this failure may not always be due to a fault in the element itself.

It is probable in many cases, that the setting of the three bi-metal retaining clips is at fault, and thus the replacement of the element alone, is not in itself enough to ensure further satisfactory operation.

In order to avoid unnecessary cost to the owner by replacing the complete lighter unit, the following procedure should be adopted where a failure of the element is reported.

1. Remove the element and knob assembly from the dashboard fitting, and dismantle by screwing out the element.
2. Screw in a new element and replace the assembly in the dashboard fitting.
3. Push in the knob, and, with a stop watch, time the period it takes to disengage. This should be 4 - 6 seconds after pushing in the knob.

NOTE:- Do not allow the knob to remain engaged more than 8 seconds, if this happens, pull out the knob and element assembly at once.

If adjustment is necessary, ensure that the Master Switch is "OFF", then, with a small screw-driver, very carefully lever outwards the three bi-metal clips in the dashboard fitting, taking care to apply equal pressure to each clip.

Re-check release time, if necessary, continue adjustment of clips until a release time of 4 - 6 seconds is obtained. When timing the release, always do so with a cold element, otherwise a false reading can be obtained.

NOTE:- The melting point of the element coil is 1300°F. This temperature can be reached after only 12 seconds engagement, so that a time of 8 seconds must not be exceeded under any circumstances.

Retailers should advise customers who have experienced element failures, that in no circumstances should the knob be pushed in and retained by hand. This has been put forward by the makers as the most frequent cause of failure. To avoid the possibility of damage the lighter must always be allowed to release itself automatically.

Bulletin

MODEL BENTLEY MARK VI

CANCELS BB.185 dated 9.4.54.

SPARKING PLUGS

It is emphasised that the correct types of sparking plug for Bentley post-war engines are as follows:-

Mark VI and 'R' Type : Champion N8B

Continental Sports
Saloon : Champion N48

The N48 plug is only suitable for the Bentley Continental engine and will almost certainly lead to misfiring if fitted to the other models.

Retailers are asked when carrying out service schedules or repairs particularly to check that the correct plugs are fitted.



MODEL BENTLEY MARK VI

FOR INFORMATION.BENTLEY CONTINENTAL SPORTS SALOONDISTRIBUTOR-OIL LEAKAGE

The tachometer drive on the Bentley Continental engine is taken from the distributor housing, the gears being fed with oil from the low pressure circuit via an external pipe. Oil leakage has been experienced from under the distributor clamping plate.

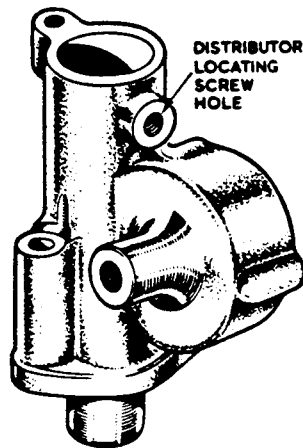

DISTRIBUTOR HOUSING
FOR THE BENTLEY CONTINENTAL

Since the locating screw for the distributor is not necessary with this type of housing a rubber sealing ring, Part No.KB.6206, was fitted to the locating groove on the distributor shank and the screw shortened. Further experience, however, has shown that the edge of the tapped hole for the screw can cut the rubber ring and destroy the seal. Until supplies of a new housing without the locating screw hole, Part No.RE.21976, are available, an aluminium blanking plug is being screwed in on production and machined off flush with the bore.

Retailers are advised that a complaint of oil leakage from the distributor should be met by fitting the rubber sealing ring and an aluminium blanking plug. The locating screw hole is tapped .250" dia 26 threads per inch, right hand, Whitworth form. The inner end of the plug should be filed or machined flush with the bore.

Bulletin

MODEL BENTLEY MARK VI

FOR INFORMATION:**SPARKING PLUGS****BENTLEY "CONTINENTAL".**

Champion N.8-B plugs are no longer approved for use on the Bentley "Continental", and are superseded by Champion NA-8. The former should be exchanged for the NA-8 when cars come in for normal servicing, and cost of the plugs charged to the Company, if the mileage is 10,000 miles or less.

Lodge CLNP are also approved and should be recommended to owners whenever possible, on account of their longer life and higher resistance to misfiring. They are, however, considerably more costly, and if fitted, are chargeable to the Owner.

Bulletin

MODEL BENTLEY MARK VI

Cancels BB-202 dated 17.11.54.

FOR INFORMATION AND ACTION.FLASHING DIRECTION INDICATOR LIGHTS.

This Bulletin is re-issued to amend the Part Number of the Scintilla Flasher Unit required. Copies of the Service Bulletin of the same number dated 17.11.54 should be destroyed.

By international agreement the flasher filament in single or double filament bulbs for flashing Direction Indicator Lights will be of 21 watts rating. All replacement bulbs will be supplied to this rating.

The majority of Bentley cars with flashing indicators have been fitted with 18 watt flasher bulbs and a Scintilla Flasher Unit rated at 36 watts although on some chassis the flasher unit may be marked 50 watts. If replacement 21 watt bulbs are fitted with a flasher unit of 36 watts, the flashing rate may be reduced below the standard of 90 to 120 flashes per minute.

Retailers are advised, therefore, that it is necessary to check the flashing rate after a new bulb, or bulbs, have been fitted. If below standard, a new Scintilla Flasher Unit rated at, and marked 36/42 watts should be fitted. This unit will operate correctly with either 21 watt or 18 watt flasher bulbs and may therefore be used to replace a faulty flasher unit where the existing 18 watt bulbs are still serviceable.

It will be appreciated that owners may change flasher lamp bulbs themselves and later complain of slow flashing.

Parts Required.

RD.8383 Scintilla Flasher Unit 12V - 36/42 W. 1 Off.



MODEL BENTLEY MARK VI

FOR INFORMATION:MARK I HEADLAMPS.

Early Series Bentley Mark VI cars, from commencement of production to Chassis No.B-191-DZ, were fitted with Mark I Headlamps, Part No.RD.3970.

Later Series, from Chassis No.B-193-DZ to B-167-NY, were fitted with modified Mark I headlamps, Part No.RD.4544. These lamps had a shallower reflector unit fitted with a thicker glass which required a wider inner rim.

The later lamp and the shallow type reflector unit are now the only available Mark I headlamp replacements.

The shallow type reflector unit can be fitted to the early Mark I lamp, provided a new inner rim and back shell adaptor are also fitted. Where it is required to replace one early type reflector unit, both lamps should be modified to the later pattern in order to maintain appearance. The following parts are therefore required:-

RD.5394	Reflector Unit Assembly.	2 off.
RD.6197	Adaptor - Back Shell.	2 off.
RD.7526	Inner Rim.	2 off.

Similarly, where one early type lamp is to be replaced complete, the other lamp should be modified by fitting a shallow type reflector to match. 1 off of each of the parts listed above are therefore required in addition to the new headlamp assembly RD.4544.

Bulletin

MODEL: BENTLEY MARK VI

FOR INFORMATION AND ACTION.

IGNITION TIMING

BENTLEY CONTINENTAL - $\frac{3}{4}$ " BORE ENGINE.

The fully-retarded, static ignition timing for the $\frac{3}{4}$ " bore engine fitted to the Bentley Continental Sports Saloon in D Series and onwards is to be altered from 2° B.T.D.C to 3° AFTER T.D.C.

Experiments have shown that the advance curve of the distributor timed at the old setting gives an excessive advance at the middle speed range which can lead to a 2% power loss at these speeds. The new setting of 3° AFTER T.D.C gives no power loss and is satisfactory at all speeds.

Retailers are asked to take the opportunity to re-time the ignition when a car is in the Service Department for other work or if there is any complaint of loss of power. Instructions for ignition timing are given in Section P of the Workshop Manual. The 3° LATE mark on the flywheel should be used.

It is emphasised that this alteration applies to the $\frac{3}{4}$ " bore engine fitted to the Bentley Continental only.

Bulletin

MODEL : BENTLEY MARK VI

FOR INFORMATION.IGNITION COILS

In order to ensure adequate supplies, Ignition Coils manufactured by Delco-Remy Ltd. have been approved for alternative use on all post-war Bentley cars.

The London Service Station may therefore despatch either a Lucas or a Delco-Remy coil of the appropriate type in response to a replacement order.

The terminals on Delco-Remy coils are marked '+' (positive) and '-' (negative). On Bentley Mk.VI and 'R' Type cars, where a positive earthing system is employed, the '+' terminal should be connected to the contact breaker and the '-' terminal to the switch. On the Bentley 'S' Type, which has a negative earth system, the '-' terminal should be connected to the contact breaker and the '+' terminal to the switch.

The terminals of Lucas coils are marked 'CB' and 'SW' and should be connected accordingly.



MODEL BENTLEY MARK VI

FOR INFORMATION.MICRO SWITCHES.

It is possible for starter motor micro-switch to be rewired incorrectly, i.e., in such a way that the circuit is not closed when the gear change lever is in the neutral position.

A diagram of the switch connections is given below.

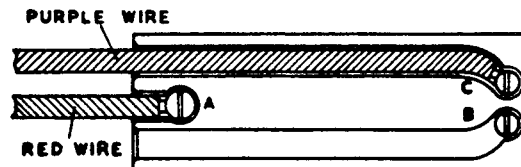

STARTER OVERRIDER MICRO SWITCH WITH
LOWER COVER REMOVED.

The 'red' wire (from the main switch box) should be connected to terminal 'A', and the 'purple' wire to terminal 'C'.

The terminals are clearly marked, and terminal 'B' should be ignored.

Bulletin

MODEL : BENTLEY MARK VI

FOR INFORMATION.

TWO SPEED WINDSCREEN WIPER ASSEMBLIES.

There is, at present, a number of two speed windscreen wiper motor assemblies which differ only in respect of the length of rack attached to the motor.

In order to simplify the ordering of spares, and to reduce the number of assemblies stocked, it has been decided to list the motors and racks separately.

The part numbers of the motors and racks are as follows:-

Description.	Lucas Part No.	Rolls-Royce Part No.
Motor	75186, 75249	CD. 572.
	(used where both wiper blades operate in unison).	
Motor	75181, 75250	CD. 573.
	(used where wiper blades operate counterphase).	
Rack (length 51.25")	-	CD.224
Rack (length 55.25")	-	CD.574
Rack (length 47.9")	-	CD.575
Rack (length 61.00")	-	CD.576

The rack length is measured from the eye of the rack crosshead to the extreme end.

These parts, which can be identified by examination, should in future be ordered separately.

Bulletin

MODEL: BENTLEY MARK VI

FOR INFORMATION.THE LUCAS IGNITION COIL AS AN ALTERNATIVE REPLACEMENT.

It has been decided to introduce a Lucas ignition coil as an alternative to the Delco-Remy coil. It is important that this is correctly connected, as otherwise, due to the fixed polarity of the coil, loss of efficiency and consequent misfiring will occur. It is also essential that the cable eye is locked to the terminal block to obviate the "spannering" effect of the stiff cable, which will otherwise result in the nut loosening and eventually falling off.

CONNECTING THE LUCAS COIL.

The light blue cable from the loom is to be connected to the "SW" terminal and the dark blue cable, which comes from the ignition harness tube is to be connected to the "CB" terminal. The black cable from the suppressor condenser is to be connected to the "SW" terminal.

CORRECT SEQUENCE OF ASSEMBLY AT THE TERMINAL.

To ensure that the cables do not work loose, the cable eyes are to be locked to the body of the coil by assembling on the terminal first the shakeproof washer, next the cable eye, and where pertinent, the suppressor condenser cable eye, followed by the plain washer and finally the knurled nut.

IDENTIFICATION.

The Lucas Ignition Coil Part No. UD.1984 can be identified by a transfer which states "For use with POSITIVE Earth System only".

Lucas coils other than the ones bearing this transfer should not be used.

CHASSIS NOS:

Bentley Mark VI and "R" Type Saloon.

Bulletin

MODEL: BENTLEY MARK VI

FOR INFORMATION.DIRECTION INDICATOR SWITCHES.

In future, "Scintilla" instead of "Trico" direction indicator switches will be supplied for replacement purposes.

Credit will no longer be given for "Trico" switches removed from the car, and reference to them should be deleted from the circular letter dated 28th December, 1956, which gave their replacement price as 16s.3d.

The full retail price for "Scintilla" direction indicator switches is £1.17s.6d.

MATERIAL.PART NO.

Scintilla Direction Indicator Switch

RH. 118.

Bulletin

MODEL: BENTLEY MARK VI

FOR INFORMATION.ELECTRIC AND WINDING CLOCKS.

The Winding Clock, part number RD.3184, fitted into the door of the cubby box in the main instrument facia panel is no longer available. A scheme has therefore been introduced to enable installation of the electric clock, part number RD.5732, in lieu of the winding clock, should replacement be necessary.

Remove the winding clock. Fit the electric clock into the recess, using one of the existing location screw holes; drill new holes for the remaining screws. Connect up the circuit, incorporating the special wiring loom provided, part number RD.5721, as shown in the diagram. Cut a hole in the right hand front corner of the cubby box interior to allow the loom passage through under the facia to connect up with the appropriate terminals.

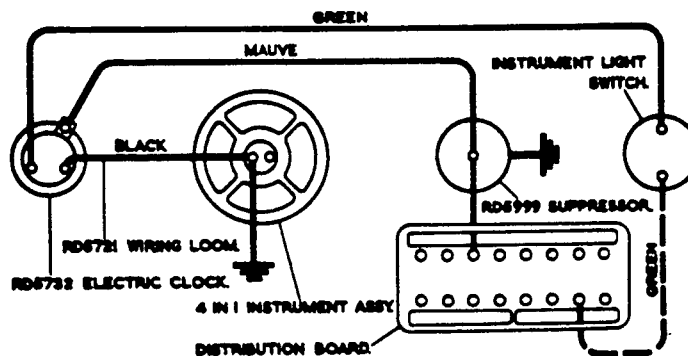
Material Required.

Electric clock.	Part No. RD.5732
Wiring Loom	Part No. RD.5721.

Bulletin

MODEL: BENTLEY MARK VI

This Bulletin cancels all
previous bulletins.FOR INFORMATIONWINDSCREEN WIPER MOTORS

A new wiper motor (DR.3. type) is now being fitted to current production cars and by reason of its greater torque output and modified design, is an improvement on the DR.1. type motor which was fitted previously.

A normal wiping speed of 35 - 40 cycles and a fast speed of 50 - 55 cycles is available with the new motor.

Installation on current production cars has been altered necessitating a reduction in the length of the first run of bundy tubing and also the use of a shorter rack.

A special mounting plate has been designed to enable the DR.3. type motor to be fitted for replacement purposes on cars previously equipped with the DR.1. type, without any alteration to the bundy tubing or rack being necessary.

To fit a DR.3. motor in place of DR.1. type, follow the procedure given in this bulletin.

Material required.

1 Wiper motor assembly	Part No. RH.712.
1 Connector	Part No. RD.6932.
1 Connector	Part No. UD.1806.
9 Terminals	Part No. RD.3425.
5 Feet Cable (red)	P.V.C.16/012.
1 Connector	Part No. RD.7050.

Disposal of material

When a DR.3. type wiper motor is fitted to replace a DR.1. type, return the DR.1. motor to Hythe Road for credit.

INSTRUCTIONS FOR FITTING DR.3. TYPE WIPER MOTOR IN PLACE OF DR.1. TYPE.To remove the DR.1. wiper motor

Unscrew the four screws and remove the cover from the wiper motor.

Remove the circlip, which retains the connecting rod followed by the plain washer, conical spring and shaped washer (see fig. 1); care should be taken when removing the conical spring as it is under compression.

Lift the connecting rod to disconnect it from the crosshead, then withdraw the crosshead and bundy tubing from the motor.

Refit the connecting rod to the gear wheel followed by the shaped washer, conical spring, plain washer and circlip.

Refit the cover and secure it to the motor with the four screws.

Continued.....

ALL COMMUNICATIONS SHOULD BE ADDRESSED TO

BENTLEY MOTORS (UK) LTD., THE LANE, CREWE, ENGLAND

Unscrew the three nuts securing the motor to the mounting bracket on the dash and detach the motor.

Disconnect the bonding braid and the five cables from the motor, cut off the terminals from the five cables and in their place fit a ferrule for a snap connector.

Detach the triangular mounting bracket from the wiper motor by removing the two 2 BA screws.

To fit DR 3 Wiper Motor.

Attach the triangular bracket to the mounting plate, supplied with the new wiper motor, by means of two 2 BA screws.

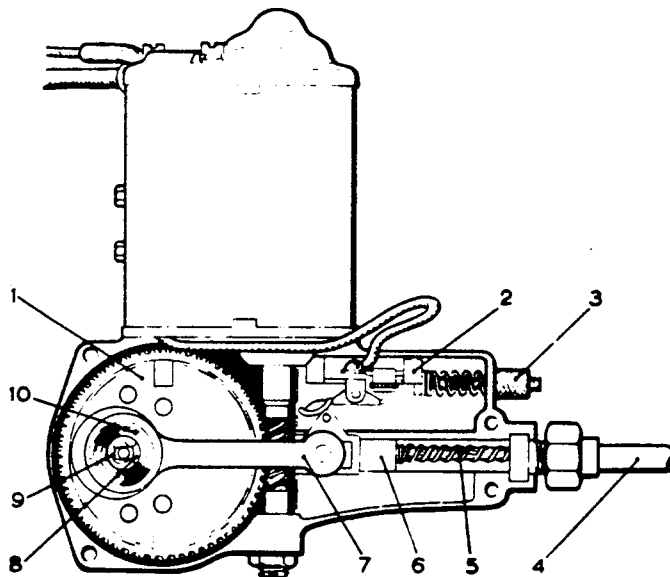

Fig.1. DR 3. Type windscreen wiper motor.

- | | |
|-------------------------|---------------------|
| 1. Gear wheel. | 6. Crosshead. |
| 2. Self-parking switch. | 7. Connecting rod. |
| 3. Adjusting nut. | 8. Plain washer. |
| 4. Bundy tubing. | 9. Circlip. |
| 5. Cable rack. | 10. Conical spring. |

Cont'd.....



MODEL: BENTLEY MARK VI

- 3 -

Fit the new motor (DR 3) to the mounting plate and secure it with the three 2 BA screws; secure the black earth wire from the motor and the bonded braid to the mounting bracket by means of one of the fixing bolts.

Fit the assembly to the bracket on the dash and secure the mounting plate with the three nuts.

Fit the crosshead to the motor by reversing the procedure adopted when removing it from the old motor.

Connect the five cables to those on the dash (see table).

Connect the cables on the new motor to the cables on the loom as follows:-

Cable on motor colour		Cable on loom colour
Brown	to	Pink
White	to	Dark Blue
Red	to	Grey
Orange	to	Purple
Green	to	Red (New feed)
Blue	to	Light Blue

To fit new feed cable.

It will be necessary to remove the facia to facilitate access to the wiper switch.

The original feed cable to the wiper motor and also the feed cable to the petrol gauge (both light blue) are connected to No. 2 terminal on the wiper switch; disconnect these cables from the switch and fit them to the double connector (UD.1806).

This connector should be fitted behind the facia adjacent to the wiper switch.

Connect one end of the new feed cable (red) to the double connector; fit a terminal for a snap connector to the free end and connect to the motor (see table).

Secure the new feed cable to the loom with insulation tape.