

Bulletin

MODEL: BENTLEY MARK VI

FOR INFORMATION:AIR CLEANERS.

Attention is drawn to the difference in air cleaners as fitted to the engines of 'A' and 'B' series Bentley Mark VI and their effect on carburation.

'A' series cars, that is B-AK and B-AJ chassis numbers are fitted with an air cleaner of Bentley manufacture (Fig.1). An engine thus fitted will have carburetter jet needles S.U. type LB1.

'B' series cars and subsequent series, that is B-HH, B-BG chassis numbers and onwards are being fitted with a cleaner of A.C. manufacture (Fig.2) which, having different air flow characteristics to the Bentley type, requires type SC carburetter jet needles to give the correct fuel/air ratio.

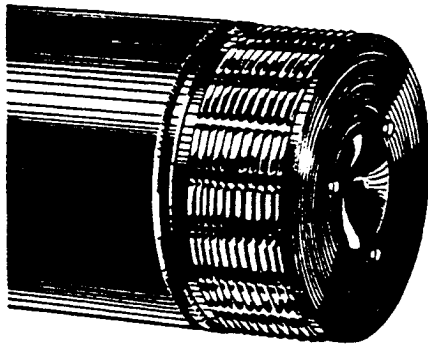


Fig.1.
BENTLEY AIR CLEANER.
USE JET NEEDLES TYPE LB1

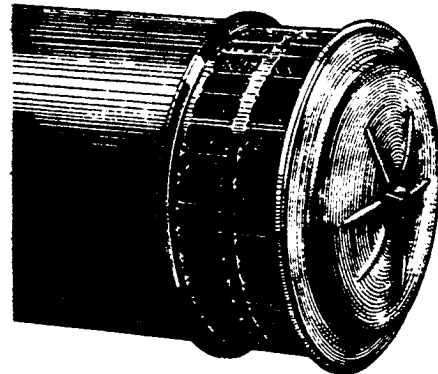


Fig.2.
A.C. AIR CLEANER.
USE JET NEEDLES TYPE SC

The A.C. type cleaner will be supplied against all orders for replacements and if required for fitting to an 'A' series car, it should be noted that the carburetter jet needles will have to be changed to type SC.

The identification markings LB1 or SC are stamped on the head of the plain portion of the jet needle which locates in the air valve.

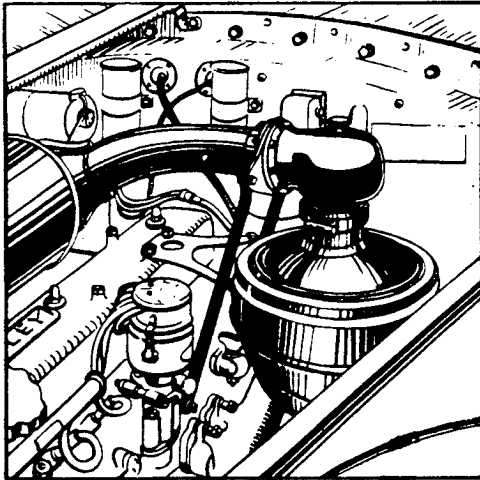
OIL BATH AIR CLEANER.FOR INFORMATION:

FIG. 1.

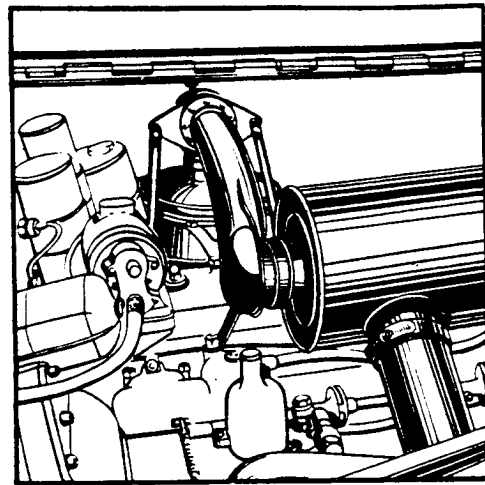


FIG. 2.

Retailers are advised that an Oil Bath Air Cleaner is available at additional cost as an alternative to the standard Air Cleaner.

The higher degree of filtration provided by the Oil Bath, gives greater protection to the engine against the abrasive effect of dust and sand, and consequently lengthens the working life of the engine. We therefore recommend this fitting for use in territories where such conditions prevail.

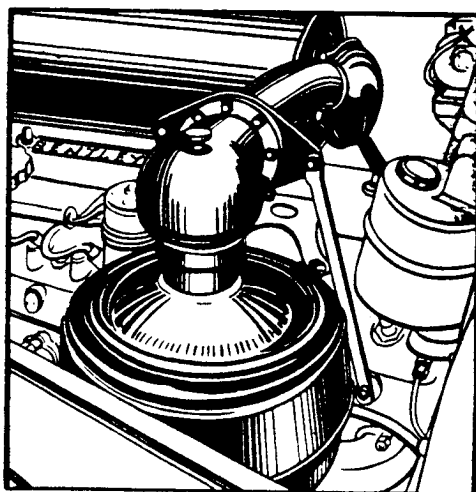


FIG. 3.

Provision can be made for the Oil Bath Air Cleaner to be fitted to customer's order before delivery, or alternatively the necessary material can be supplied for incorporation after delivery.

When this cleaner is fitted, it is necessary to modify the carburetors to counteract the difference in the rate of air flow and maintain the standard of carburation and performance.

The completed assembly is shown in Figs. 1, 2 & 3, and the procedure for modifying the carburetors and fitting the Oil Bath Air Cleaner, together with a list of the parts required, follow on Pages 2 to 6.

ALL COMMUNICATIONS SHOULD BE ADDRESSED TO
BENTLEY MOTORS (1931) LTD. SERVICE STATION, HYTHE ROAD, WILLESDEN, LONDON, W.2

Bulletin

MODEL : BENTLEY MARK VI

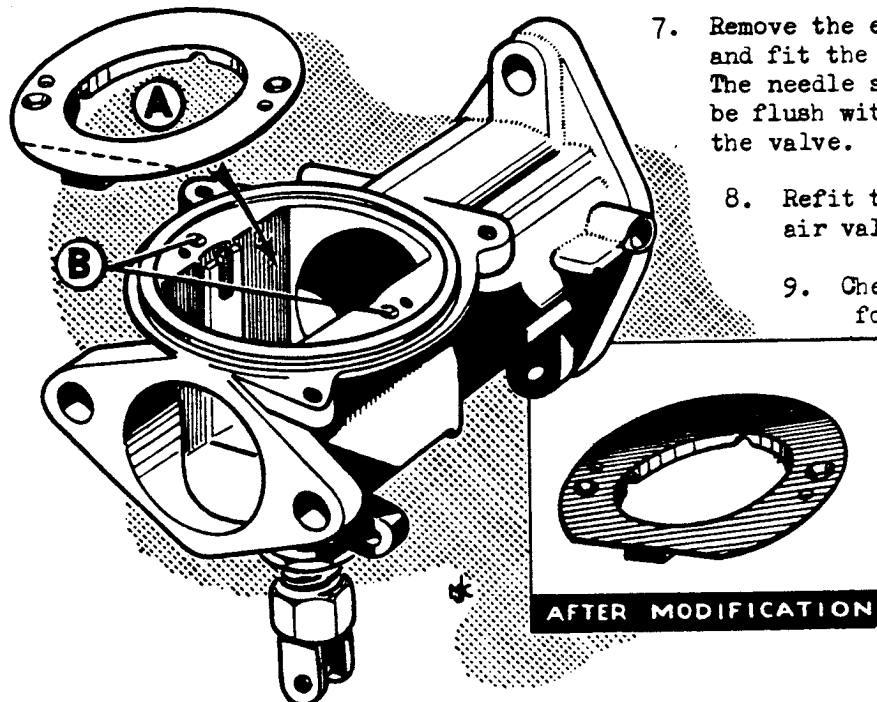
- 2 -

MODIFYING THE CARBURETTORS:

It is advisable to complete the modification of each carburettor separately to avoid interchanging the air valves, air chambers, etc.

PROCEDURE:

1. Remove carburettor air intake.
2. Remove the carburettor air chamber and valve.
3. Mark off in position the segment of the air valve plate (A) indicated in Fig.4. The chord of the segment, shown by the dotted line, is 1.500" (38.1 m/m) and is parallel to the face of the carburettor intake flange.
4. Remove the two countersunk screws securing the air valve plate and lift off the plate.
5. Grind off segment as indicated in Fig.4. (Grinding is recommended to obviate the risk of distortion caused by holding this plate in the vice to use hacksaw and file).
6. Plug the air passages (B) in Fig.4 with prepared aluminium plugs. These plugs must be flush with the surface or slightly countersunk to avoid interfering with the seating of the air valve plate. It is recommended that the holes be taper reamed and suitable plugs be prepared, so that when tapped lightly home, they do not project above the face.



7. Remove the existing needle and fit the type SE supplied. The needle shoulders should be flush with the face of the valve.
8. Refit the valve plate, air valve and chamber.
9. Check the air valve for freedom.

FIG. 4.

ALL COMMUNICATIONS SHOULD BE ADDRESSED TO
BENTLEY MOTORS (1931) LTD., SERVICE STATION, HYTHE ROAD, WILLESDEN, LONDON, N.W.10

- 3 -

There is a possibility that during the removal of the segment from the air valve plate, slight distortion may have taken place. This will cause the air valve to stick due to a foul in the bore. To overcome this fault, mark the fouled bore by raising and lowering the air valve several times and remove the hard marks from the bore with a suitable half round scraper.

10. Refit the carburettor air intake.

FITTING THE OIL BATH AIR CLEANER:

When this type of air cleaner is fitted, it is necessary to re-position the oil syringe and grease gun, which are clipped to the inside of the wing valance on the left-hand side, to facilitate the removal and refitting of the oil bath air cleaner bowl and element.

The grease gun clips are moved to the forward side of the oil can, to the position shown in Fig.5. The oil syringe clips are removed and refitted to the ledge of the wing valance so that the handle of the syringe, when clipped in position, will be approximately on the centre line of the original grease gun position.

The clips for carrying these tools are riveted to the wing valance. The rivets should be drilled out, the holes filled with suitable aluminium plugs, and the clips fitted to the new positions with 2-BA countersunk setscrews of a suitable length.

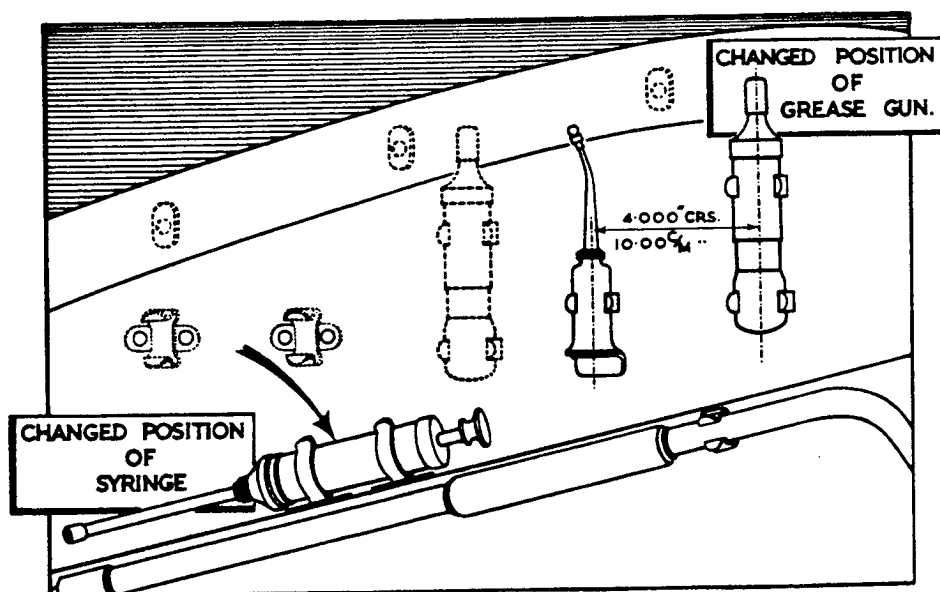


FIG. 5.

Bulletin

MODEL: BENTLEY MARK VI

- 4 -

PROCEDURE:

1. Remove the existing air cleaner complete.
2. Remove the rocker cover and breather if fitted.
3. Drain the coolant system.
4. Disconnect the car heater feed pipe from the tap at the rear end of the cylinder head.
5. Remove Nos.4 and 6 cylinder head core plugs.
(The two holes in the core plug are provided for tightening the plug with a two-pin spanner on initial assembly. They are not intended for use in removal, since under normal conditions, removal should not be necessary. The plug is fitted with jointing compound, and it is anticipated that withdrawal may be difficult. If the existing holes are joined by chain drilling, a broad metal strip can be used as a screwdriver with a large adjustable spanner to provide leverage. Plugs may sometimes be loosened by tapping with an aluminium drift before unscrewing).
6. Fit the special studded core plugs with aluminium washers and jointing compound.
7. Tighten the car heater tap through approximately 15° so that when the pipe is attached, it will clear the rear core plug stud. Attach the pipe.
8. Fit the replacement rocker cover with a new joint washer and transfer the chromium plated set bolts from the original cover to the unused threaded bosses on the new cover. If a rocker cover breather is fitted, remove the core plug in the replacement rocker cover and fit the breather.
9. Remove the forward support bracket from the original air cleaner and fit to the air silencer. (If this bracket is riveted to the cleaner, as on AK and AJ chassis series, a new bracket is supplied).
10. Assemble the transverse pipe and elbow with the oval support plate inserted between the flanges and a vellumoid joint washer on each side.
11. Place a rubber sealing ring and Jubilee clip on the banjo end of the transverse pipe, assemble loosely to the rear of the silencer, and fit the silencer to the induction pipe with the sealing ring and clip from the original air cleaner. Secure the front support bracket.
12. Fit the support legs to the oval support bracket, secure the lower ends to the studded core plugs, tighten the Jubilee clip at the banjo end and tighten the banjo support leg.

ALL COMMUNICATIONS SHOULD BE ADDRESSED TO:

BENTLEY MOTORS (1931) LTD. SERVICE STATION, FIVE THE ROAD, WILLESDEN, MIDDLESEX, ENGLAND

SECTION

Bulletin

MODEL BENTLEY MARK VI

- 5 -

13. With the lugs downwards, fit the strap to the top half of the oil bath with the set screws and spring washers and bolt the 'Y' shaped bracket to it. (The set in this bracket should be downwards).
14. Place a rubber sealing ring and 'Jubilee' clip on the transverse pipe elbow, assemble the upper half of the oil bath to the elbow and secure the bracket to the rocker cover.
15. Fill the base chamber with oil to the correct level with a viscosity S.A.E.20 oil as used in the engine, insert the filter element and fit into position securing with the long bolt passing through the elbow.
16. Radius the bonnet support rod, which is clipped to the inside of the wing valance, sufficiently to clear the oil bath, making allowance for engine oscillation under running conditions.
17. Warm up the engine, check the slow running and adjust if necessary.

PERIODIC MAINTENANCE:

The oil container and filter element will require periodic cleaning. When they are removed for this purpose, the oil container should be emptied and carefully cleaned, and the filter element should be thoroughly washed in petrol and allowed to dry. The oil container should then be refilled to the indicated level with a viscosity S.A.E.20 oil.

The specific intervals at which cleaning will be necessary will be dependent upon prevailing conditions and will be more readily determined by experience in the territory in which the car is used.

It is suggested that inspection should be made initially at short intervals of about a fortnight, to provide information for establishing maintenance periods in a particular area. The information thus gained may form the basis for action on all subsequent cars fitted with an oil bath air cleaner.

Bulletin

MODEL BENTLEY MARK VI

-6-

The following list of parts may be used for ordering replacements or checking the material supplied:-

1	RE.6196	Rocker Cover with RE.5464)	} Supplied Assembled
		Breather Insert	
2	KB.399	Studs.	
1	KB.7305	Core Plug	} Studs to secure 'Y' bracket to rocker cover
1	RE.5151	Rocker Cover Joint	
1	RE.6725	Air Silencer	
1	RE.6206	Air Cleaner	
1	RE.6275	Strap	} Strap for securing 'Y' bracket to upper part of Oil Bath Air Cleaner
3	KC.201	Setscrews	
3	K.9008	Washers	
1	RE.6275	Banjo Tube Assy	
1	RE.6269	Plate	
2	RE.6270	Washers	Vellumoid washers
1	RE.6278	Elbow	
8	K.131	Bolts	} Securing Banjo pipe to Elbow with Plate and Vellumoid washers interposed.
8	K.4307	Nuts	
8	K.9006	Washers	
1	RE.6277	Bracket	'Y' shaped bracket
2	RE.6276	Stays	Support stays from oval plate to special core plugs.
2	RE.6264	Plugs	} Special core plugs and aluminium washers.
2	E.27491	Washers	
4	KA.201	Bolts	} To bolt top of support stays to plate and to fix 'Y' bracket to strap on Air Cleaner
4	K.4310	Nuts	
4	K.9008	Washers	
2	K.4008	Nuts	} Securing support stays to special core plugs
2	K.9008	Washers	
2	KB.3905	Washers (Chamfered, plain)	
2	K.4310	Nuts	} Securing 'Y' bracket to studs on rocker cover.
2	K.9008	Washers	
1	RE.6732	Jubilee Clip	} Elbow to Oil Bath Joint
1	RE.6271	Sealing Ring	
1	RE.4805	Jubilee Clip	} Banjo Tube to air silencer joint
1	RE.4804	Sealing Ring	
2	SU Jet needles, Type SE.		
1	RE.5608	Support bracket	} Necessary for AK and AJ series only where forward support bracket is riveted to the Air Cleaner.
2	KC.201	Setscrews	
2	K.9008	Washers	

ALL COMMUNICATIONS SHOULD BE ADDRESSED TO:
BENTLEY MOTORS (1931) LTD., SERVICE STATION, MYTHE ROAD, WILLESDEN, LONDON, N.W.10

SECTION

Bulletin

MODEL BENTLEY MARK VI

FOR INFORMATION.FUEL PUMP SERVICING

The twin S.U. fuel pumps which are fitted to the chassis side member just to the rear of the battery are protected against the effects of dust and water by rubber sleeves.

In each sleeve there is a small hole to provide ventilation, and there is also an equivalent hole at the bottom of each pump body between the diaphragm and energising coil to prevent internal condensation.

On any occasion when the pumps require attention, these breather holes should be checked to ensure that they are clear and the rubber sleeves should be replaced with the air holes at the lowest point. In addition, it will be noted that the sleeves are not symmetrical at each end, one end having a considerably longer flange. This end should be fitted away from the main body. If the position is reversed, the longer flange may cover the breather hole in the coil casing.

The condensation which takes place if these precautions are not taken, may be sufficient to cause failure of the pumps.

Bulletin

MODEL: BENTLEY MARK VI

CARBURETTOR JET CORRECTIONS
FOR ALTITUDES ABOVE SEA LEVEL.

FOR INFORMATION.

In various parts of the world, Bentley Mark VI's are operating at altitudes considerably above sea level, and the following information is offered to Agents who have experienced difficulty in obtaining satisfactory carburation from the vehicles in their territories.

Whilst it is true that with an increase in altitude, the mixture strength of a fixed jet type of carburettor, such as the Stromberg fitted to the left-hand drive Bentley Mark VI, tends to become stronger, tests have shown that up to 4,000 ft. above sea level, these engines will operate perfectly satisfactorily without any jet alterations being made.

If at altitudes above 4,000 ft difficulty is experienced in obtaining satisfactory running or petrol consumption, the jets may be changed. Care should be taken however, to ensure that the fault does not lie outside the carburation system, and that it is actually the carburettor which requires adjusting.

The Stromberg carburettor requires no further adjustment other than a change of main jet for altitude, but it must be borne in mind that whenever an alteration is made to a jet to give satisfactory performance at altitude, a corresponding correction must be made when the car returns to sea level. This may prove inconvenient to Owners who habitually visit localities at sea level and others which are higher up, and in such cases, a jet should be fitted to give the best performance at the altitude at which the car most frequently operates.

The two constant-vacuum S.U. carburettors fitted to the Bentley Mark VI right-hand drive cars, by virtue of their self-adjusting piston chokes, give satisfactory results at altitudes up to 6,000 with sea level settings, and no needle correction is considered necessary. Normal carburettor adjustments are all that should be required to obtain good performance and slow running at 6,000 ft. or over. When the car temporarily returns to sea level, the Owner can, by moving the mixture control lever a few notches towards the 'Starting' position, regain the correct mixture strength and good slow running without having the carburettor re-adjusted.

The following table will serve as a useful guide when making jet variations for L.H. drive cars.

Bulletin

MODEL: BENTLEY MARK VI

- 2 -

APPLICATION:SETTING VARIATIONS:

	<u>Sea Level:</u>	<u>4000/7000' above sea level.</u>
Bentley Mark VI(LH) A.C. air silencer	Main Jets. .045 broad ring. Power Jet. No. 54 Idle Jets. No. 70 Idle air No. 60 bleeds.	Main jets .041 broad ring. No change. " "
Bentley Mark VI(LH) oil bath air cleaner.	Main Jets. .042 broad ring. Power Jet. No. 57 Idle Jets. No. 70 Idle air No. 60 bleeds.	Main Jets .040 broad ring. No change. " "

ALL COMMUNICATIONS SHOULD BE ADDRESSED TO

BENTLEY MOTORS (1931) LTD., RYMS LANE, CREWE, ENGLAND

SB/PC. 10/SF. 6.1.50.

PRINTED IN ENGLAND

SECTION M

Bulletin

MODEL: BENTLEY MARK VI

FOR INFORMATION:MODIFICATION OF AIR SILENCER - AIR INTAKE COUPLING
TO PREVENT NOISE TRANSMISSION FROM AIR SILENCER.

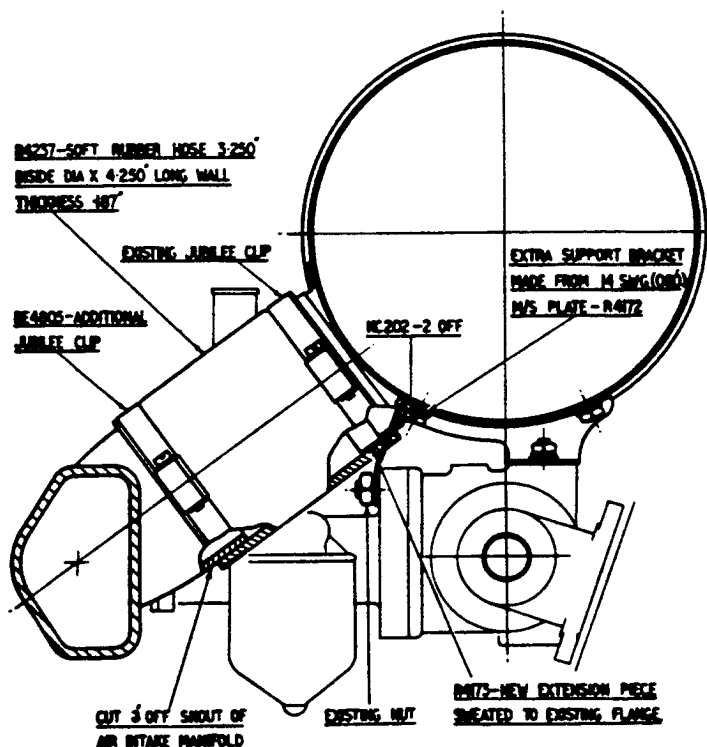
Reports have been made in a few instances, of an unusual vibratory noise in the engine of the Bentley Mark VI.

Investigation has proved that this noise is transmitted from the air silencer, and that by pushing with the palm of the hand on the air silencer, whilst the engine is running, the intensity of the noise can be reduced.

The modification suggested to cure complaints of this nature, consists of replacing portion of the air intake coupling with a section of rubber hose, in accordance with the instructions detailed below:-

PROCEDURE:

1. Disconnect the Jubilee clip between the air cleaner and air intake.
2. Remove the air silencer and cleaner.
3. Remove the air intake from the carburettors.



4. Measuring from the face of the joint between the air intake and air silencer, cut 3.000" off the air intake snout.

ALL COMMUNICATIONS SHOULD BE ADDRESSED TO:

BENTLEY MOTORS (1931) LTD. FYM'S LANE, CREWE, ENGLAND

Bulletin

MODEL: BENTLEY MARK VI

- 2 -

5. Allowing a 1/2" overlap, slide the new extension piece R-4173, over the existing air silencer coupling flange, and sweat in place, so as to extend the effective length of the air silencer coupling by 1/2". Touch up the joint with black enamel.
6. Refit the air intake to the carburettors.
7. Fit the rubber hose R-4237 over the shortened snout of the air intake.
8. Remove the two existing 3/8" bolts; nearest the coupling flange from the anchor brackets of the air silencer as shown in the illustration. Replace by two longer bolts KC-202 and secure the two new support brackets R-4172 under these bolts, so that the lower portion of the brackets lies vertically.
9. Refit the air silencer. The two extra support brackets should fall opposite two of the 1/2" retaining nuts, between the carburettors and inlet manifold, and should be secured under these nuts.
10. Slide the end of the rubber hose R-4237 over the extended air silencer flange.
11. Secure the two ends of the rubber hose with Jubilee clips.

MATERIALS REQUIRED:

R-4237	Rubber Hose.	1	Off.
R-4172	Support Brackets.	2	"
R-4173	Extension Piece.	1	"
RE-7805	Jubilee Clip.	1	"
KC-202	Bolts 3/8"	2	"

Bulletin

MODEL: BENTLEY MARK VI

FOR INFORMATION:INCORPORATION OF RUBBER CONNECTION PIECE BETWEEN AIR SILENCER AND
CARBURETTOR TO ELIMINATE VIBRATION - L.H. DRIVE BENTLEY MK. VI(NOT APPLICABLE TO CARS WITH OIL BATH AIR CLEANERS.)

A few instances of an unusual high pitched vibratory noise in the engine have been reported by owners of left-hand drive Bentley MK. VI cars.

Investigation has shown that this noise is transmitted from the air silencer, and that by pushing on the silencer with the palm of the hand whilst the engine is running, the intensity of the noise can be greatly reduced. (N.B. As a means of guidance, the noise is usually most noticeable at engine speeds approximating to 22/25 m.p.h. and 38/40 m.p.h. in second and third gear respectively).

In order to overcome this trouble, a flexible rubber connection piece for use between the silencer and carburettor has been introduced, and Retailers are recommended to incorporate this whenever dealing with complaints of noise transmission from the air silencer.

This will involve the modification of the existing silencer in accordance with the instructions detailed below.

MODIFICATION PROCEDURE.

NOTE: Figs. 1 & 2 illustrate the air silencer before and after modification and are given as a means of guidance to Retailers when carrying out the following instructions.

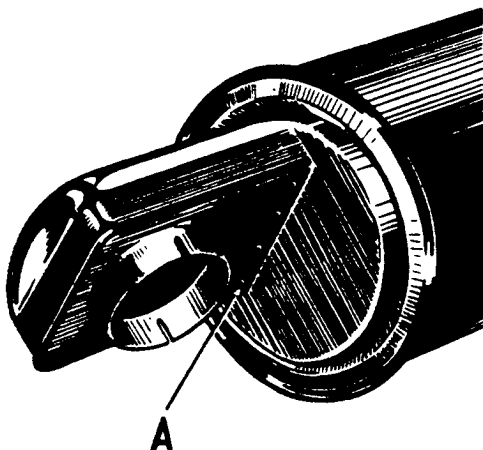


FIG. 1.

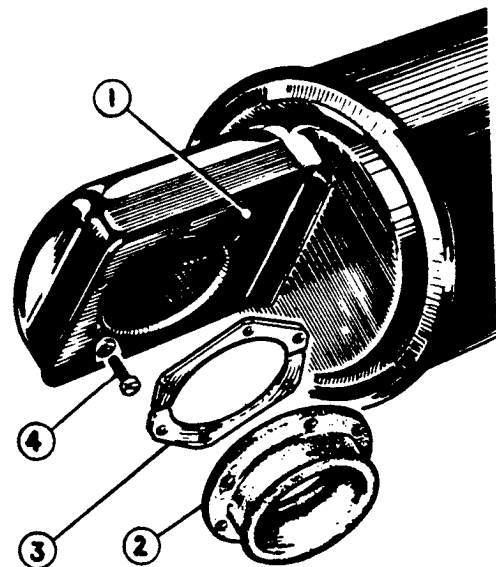


FIG. 2.

ALL COMMUNICATIONS SHOULD BE ADDRESSED TO
BENTLEY MOTORS (1931) LTD., PYM'S LANE, CREWE, ENGLAND

Bulletin

MODEL: BENTLEY MARK VI

- 2 -

1. Slacken the jubilee clip at top of the carburettor, remove the two 1/4" nuts and bolts securing the silencer body to the top of the support legs and remove assembly from engine.
2. Lay the assembly on its back upon a bench, i.e. with the air intake orifice uppermost, and drill away the spot welding at the rear end of the cover plate (points 'A' Fig.1) using a flat nose 1/4" drill. (N.B. Care should be taken to ensure that the drill does NOT penetrate the supporting strip BELOW the cover plate.)
3. Carefully roll back the lapped edge round the existing cover plate and remove plate. Clean up and tin the supporting strip.
4. Clean and tin the new cover plate, RE-9868, (1, Fig.2) to correspond with the supporting strip, fit the plate and sweat in position as shown (the new plate should be fitted with the lip of the orifice uppermost). Roll back the lapped edge as before, and then touch up both plate and edges with black enamel.
5. Pass the new rubber connection piece, RE-9691, (2, Fig.2) through the orifice of the new cover plate, flanged end first, and then coincide the six screw holes in its flange with those drilled in the plate. Next pass the new metal retaining plates, RE-9690 (3, Fig.2) through the orifice of the rubber connection piece, coincide the holes, and secure in position by means of the six 3-BA setscrews (4, Fig.2) supplied.
6. Refit the silencer assembly, using the existing jubilee clip to secure the rubber connection piece to the carburettor air intake.

MATERIAL REQUIRED.

RE-9868	Cover Plate - Silencer Air Intake.	1	Off
RE-9690	Retaining Plate - For Rubber Connection Piece(2 halves)	1	"
RE-9691	Rubber Connection Piece - Silencer to Carburettor.	1	"
K -1804/Z.	Setscrew - 3 BA for above.	6	"
K -9005/Z.	Spring Washer - for above.	6	"

ALL COMMUNICATIONS SHOULD BE ADDRESSED TO
BENTLEY MOTORS (1931) LTD, PYM'S LANE, CREWE, ENGLAND

LEFT-HAND DRIVE BENTLEY MARK VI.STROMBERG CARBURETTOR.

Cases have occurred where a flat spot on acceleration from slow speeds has been traced to insufficient petrol ejection from the accelerator pump, one reason for which may be excessive petrol leakage past the fuel bleed ball valve in the piston. This can be overcome by sealing the inlet passage to the ball valve at 'A' (See drawing below).

Instructions are appended for modifying cars in this manner - the modification being recommended in all cases where the owner complains of poor acceleration or of a flat spot in the acceleration curve at low speeds.

It is necessary for the carburettor to be removed from the car.

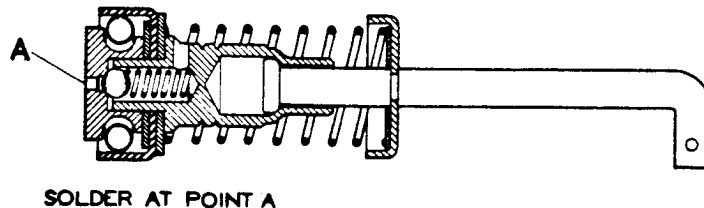


FIG. 1. ACCELERATOR PUMP PISTON - SHOWING BLEED HOLE.

1. Remove the air silencer.
2. Disconnect the fuel feed pipe at the union.
3. Disconnect the throttle control from the throttle body lever.
4. Remove the nut and washer from the strangler spindle and disconnect the lever from the spindle.
5. Remove the carburettor from the manifold.
6. Disconnect all the carburettor linkage - the pump lever screw has a left-hand thread.



MODEL

BENTLEY MARK VI

- 2 -

7. Remove the carburettor top together with the accelerator pump piston assembly.
8. Seal off with solder the inlet bleed passage as shown in Fig. 1.
9. Replace the carburettor top, taking care not to trap the leather washer between the two faces.
10. Assemble the carburettor and fit to the engine.

Petrol consumption is increased by little more than 1% as a result of this modification.

Bulletin

MODEL BENTLEY MARK VI

FOR INFORMATION:

AUTOMATIC S.U. CARBURETTERS

These carburetters are now fitted as standard equipment on all Bentley cars from "R" series and onwards.

The object of this change is to dispense with the manual control and also to improve the cold starting characteristics.

Description:

The automatic system consists of five main features:-

1. An out of balance butterfly valve in the common air intake pipe.
2. A diaphragm, subject to induction pipe depression, and indirectly coupled to the butterfly valve spindle.
3. A small electro-magnet wired in parallel to the starter relay circuit.
4. A cam for "fast idle", loose coupled to a pick-up lever connected to the butterfly spindle.
5. A bi-metal coil coupled to the butterfly valve and subject to engine coolant temperatures.

The operating sequence is as follows:-

Before pressing the starter button, it is necessary to depress the accelerator pedal, in order to release the "fast idle" cam and allow the bi-metal coil to close the butterfly valve. On releasing the accelerator pedal, the throttle opening is greater than that for normal idling, by virtue of the extra stop resting on the "fast idle cam".

In parallel with pressing the starter button, the electro-magnet is automatically energised and the armature on the butterfly spindle holds the butterfly valve in the fully closed position. Immediately the button is released, the circuit to the electro-magnet is broken, and this, therefore, loses its power to hold the butterfly closed.

As soon as the engine is running, the induction pipe depression is exerted on the diaphragm which transmits its energy to the loose lever on the butterfly spindle. The loose lever turns the spindle to open the butterfly valve a predetermined amount, controlled by an adjustment on the diaphragm movement. The power of the diaphragm is such that it opens the butterfly against the loading of the bi-metal coil. Since the loose lever is slotted and its travel is limited, the butterfly spindle can over-ride the movement of the loose lever.

As the engine continues to run, the coolant jacketed pocket into which is fitted the bi-metal coil, will gradually warm up and transmit its heat to the coil, when the bi-metal coil warms up, it will wind up and gradually release the load on the butterfly, which in turn will gradually open.

With the depression of the accelerator pedal for the drive away, the fast idle stop on the throttle shaft will move away from the cam and the cam will fall on to the pick-up lever, coupled by a rod to the butterfly spindle. The loading of the bi-metal coil and the offset of the butterfly have been so arranged that any air flow greater than that required for "fast idle" automatically opens the butterfly against the load exerted by the bi-metal coil, sufficient for engine requirements.

Assembly and Setting Procedure:

Carburetters: (Before installing in position).

1. Fit RE.17011, throttle lever, to front carburetter. Angle of spring anchorage section should be 20° from vertical, throttle closed.
2. Assemble couplings RE.17012/17047 as complete separate units and then fit these to carburetters as shown in Fig. 1. (Illustration, is position with fully closed throttles).

Give rear carburetter coupling approximately .020" clearance on the carburetter body.

Insert RE.17008, coupling shaft, into RE.17012 couplings (do not tighten pinch bolts) and fit carburetters to induction pipe.

(In position):

1. Fit air intake and throttle return spring. Screw back throttle stop to allow throttle to close fully.

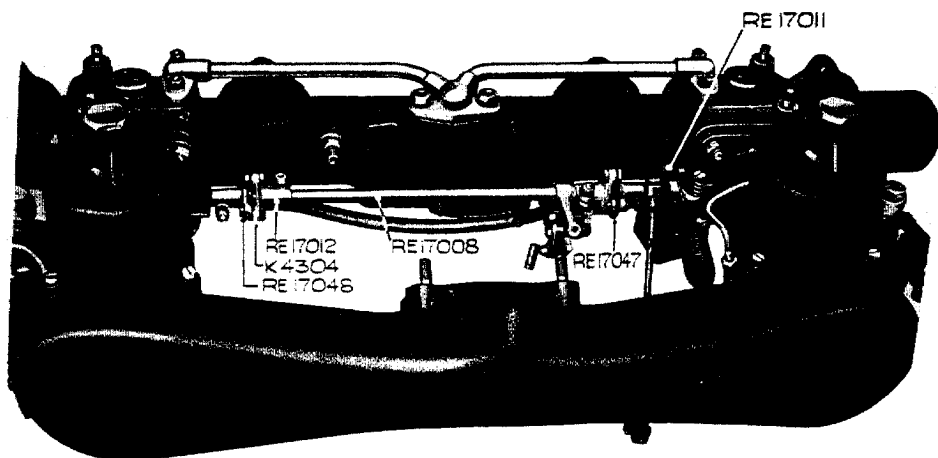


FIG. 1. CARBURETTERS ASSEMBLED.

Bulletin

MODEL: BENTLEY MARK VI

- 3 -

2. With front carburetter throttle fully closed, tighten coupling pinch bolt to give .098" clearance between the fast idle cam and the cam lever, see Fig. 2. The cam adjusting screw hole should be central with the cam face. Hold rear carburetter throttle in fully closed position and tighten remaining pinch bolt in shaft coupling.

Choke Valve: (Before installing in position)

1. Check that valve makes a reasonably good seal and that it operates freely in the spindle bushes.
2. With the choke valve in the closed position, a small radial clearance, .010", is necessary between RE.13008 pin and the pick-up lever RE.13204, Fig.3. This is obtained by adjusting the length of RE.17003 rod, with the adjusting washers RE.17040/2, Fig. 4.
3. Fit the diaphragm assembly and adjust the "kick-gap" as shown in Fig. 6.
4. With the choke valve in the closed position, adjust the air gap to .004"/.006" between the lever RE.13207 and the Solenoid yoke by using shims RE.17043/5, Fig. 5.

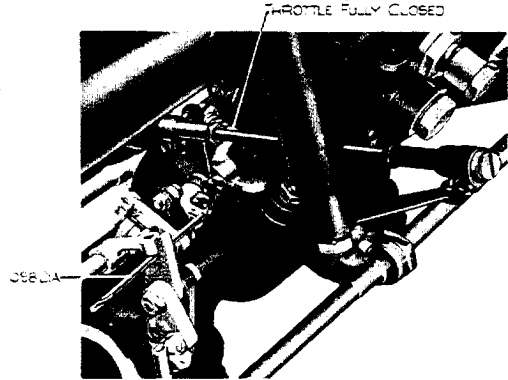


FIG. 2. FAST IDLE CAM AND LEVER ADJUSTMENT.

To ensure a given magnetic flux density from unit to unit with the specified air gap of .004"/.006", it is necessary that the RE.13207 lever and the Solenoid yoke faces must be parallel.

(In position):

1. Fit completed choke valve body to air intake.
2. Fit the depression pipe between kick diaphragm cover and the induction pipe.
3. Fit thermostat unit to housing in induction pipe.

Initial Assembly Adjustments

1. Adjust throttle stop screw to open throttles $\frac{1}{2}$ turn from the fully closed position.

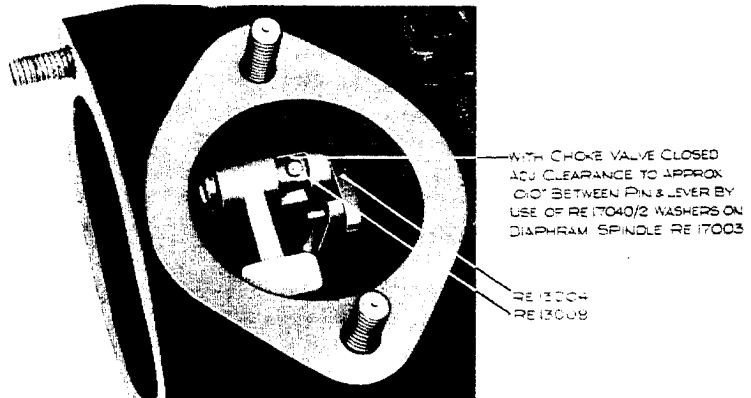


FIG. 3. PICK-UP LEVER CLEARANCE.

Bulletin

MODEL BENTLEY MARK VI

- 4 -

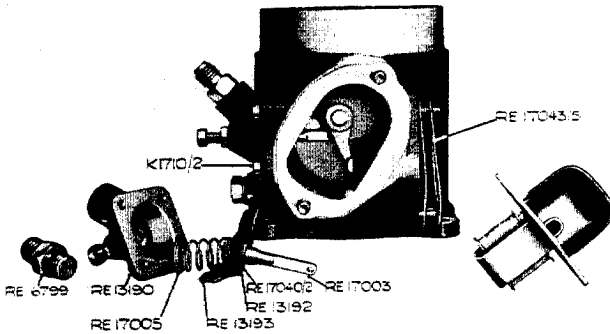


FIG.4. CHOKE VALVE DISMANTLED.

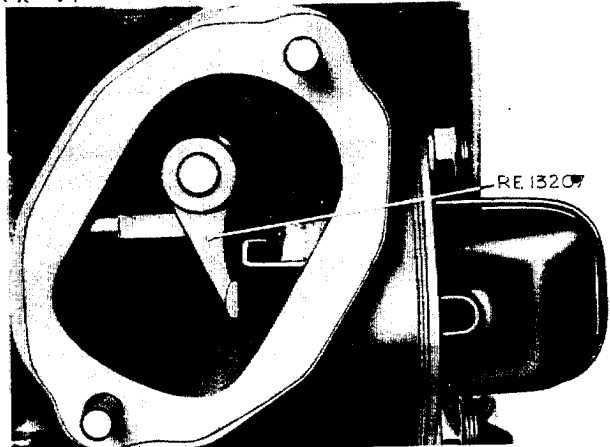
2. Fit RE.17013 screw and lock nut to RE.19020 lever, and with the screw nose resting on the high stop of the fast idle cam, adjust RE.17013 screw to give .030" clearance between the throttle stop screw and the throttle stop lug. See Fig.7.
3. Fit and adjust RE.13211 rod, with the choke valve fully closed to give .031" clearance between the thermostat lever and stop. See Fig. 8.

Fit and adjust RE.13212 rod, choke valve to fast idle pick-up, as shown in Fig.8.

These rods are threaded left- and right-hand to facilitate adjustment and should be started in the threaded ball ends simultaneously.

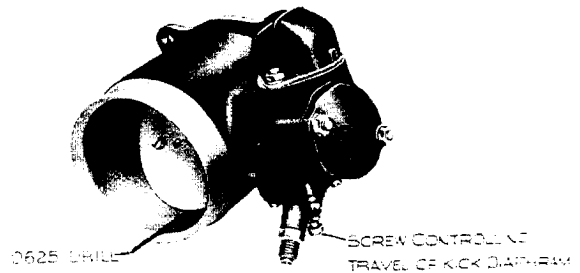
Final Test Adjustments:

Although there are no external levers, etc., on this type of carburetter by which to operate the jets, the principle of the jet adjustment is the same as on the hand controlled carburetter. A brass screw at the base of the jet assembly moves the jet tube up or down, the screw is exposed after removing the cap nut.



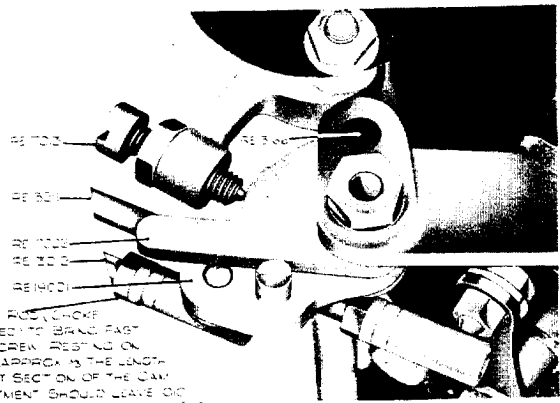
LEVER & MAGNET COIL YOKE FACES MUST BE PARALLEL ONE TO ANOTHER WHEN IN POSITION GAP BETWEEN LEVER & YOKE FACES TO BE ADJUSTED TO .004/ .006" BY USE OF SHIM WASHERS RE 17043/5

FIG.5. ADJUSTMENT OF MAGNETIC CAP.



ADD KICK DIA DIAPHRAM TRAVEL TO ENABLE 0.625 DRILL TO ENTER AS SHOWN WHEN CHECKING GAP LIGHTLY HOLD CHOKE VALVE CLOSED & PRESS DOWN ON PIVOT END OF RE.17003 LINK

FIG.6. ADJUSTMENT OF KICK GAP.



ADJUST THE ROD (CHOKE VALVE CLOSED) TO BRING FAST IDLE CAM SCREW RESTING ON A POINT AT APPROX 1/3 THE LENGTH OF THE FIRST SECTION OF THE CAM. THIS ADJUSTMENT SHOULD LEAVE 0.031" CLEARANCE AT LEAST BETWEEN THE EDGE OF THE CAM & THE STOP ON RE. 17006

FIG.7. SETTING THROTTLE STOP.

ALL CORRECTIONS SHOULD BE REFERRED TO BENTLEY MOTORS (VM) LTD. SERVICE STATION, 21 THE ROAD, STAINLEIGH, LONDON, N.W.2

MODEL : BENTLEY MARK VI

- 5 -

Having finally set the engine idling, (mixture and speed), it will be necessary to re-adjust the fast idle cam screw RE.17013 to obtain the .030" clearance between the throttle stop screw and the lug as previously described. This should be done with a cold engine to ensure consistency of setting, a small variation of .002"/.003" can make a appreciable difference to the starting speed of the engine.

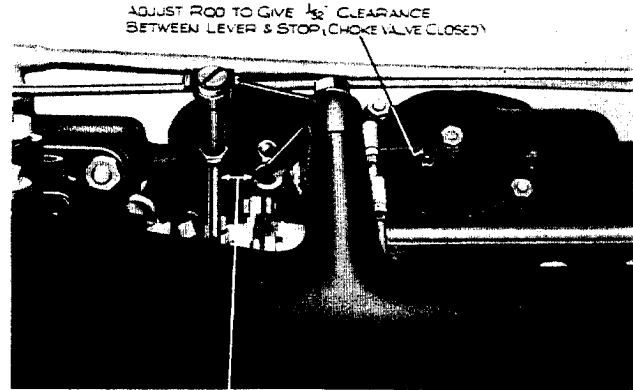


FIG. 8. ADJUSTMENT OF THERMOSTAT LEVER.

The adjustment of the fast idle cam pick-up rod RE.13212, does, in a minor way, control the "warming up period" fast idle speeds, as the length of the rod alters the relative positions of the fast idle screw and the fast idle cam.

The dual bi-metal coil unit has been set to a given torque in a constant temperature room (68°F), and in the event of fitting one or two new coils, the torque should be checked and reset as under:-

1. Adjustment of the unit must take place in a constant temperature of 68°F. The unit should be assembled and left to stabilise at that temperature for at least 2 hours.
2. With the lever as shown in Fig. 9, the coils are to be pre-set so that a total weight of 178 - 181 grammes acting at "B" just moves the lever clear of the stop.

Since the coils are temperature sensitive, they must not be handled whilst adjusting.

3. After setting, mark plate at pointer with centre punch.

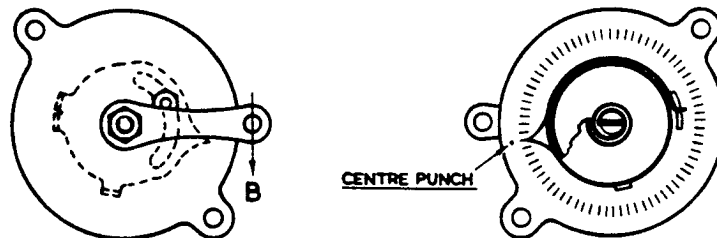


FIG. 9. BI-METAL COIL ADJUSTMENT.

MODEL BENTLEY MARK VI

FOR INFORMATION:MODIFICATIONS TO AUTOMATIC TWIN S.U. CARBURETTERS
TO IMPROVE COLD STARTINGCATEGORY 3A:1. SETTING MODIFICATIONS:

On a customer's complaint of poor cold starting, the following modifications and checks should be carried out:-

- (i) Replace the bi-metal thermostat with one of an increased loading of 200 - 205 grammes.
- (ii) Reset the kick diaphragm travel to .090".
- (iii) Check the solenoid air gap as .002" - .006".

TO REPLACE THE BI-METAL THERMOSTAT:Material Required:

<u>Part No.</u>	<u>Title.</u>	<u>No. Off.</u>
RE.17037Z	Assembly Thermostat.	1.

This thermostat was originally set at a loading of 178 - 181 grammes at 68°F as explained in our Bulletin No. BB-157, but it is now recommended that the loading be increased to 200 - 205 grammes at 68°F. Replacement units set to the new loading will be supplied on application to this Depot. Old units should be returned for credit in the normal way, and no attempt should be made to adjust the bi-metal spring to the new setting.

FITTING INSTRUCTIONS:

- (i) Undo the 2 BA nut holding the lower ball jointed end of the link rod from the choke valve to the thermostat lever.
- (ii) Undo the two 2 BA nuts retaining the thermostat unit in its housing.
- (iii) Refit the new thermostat.
- (iv) Check the clearance between thermostat lever and its stop, as shown in Fig. 1.

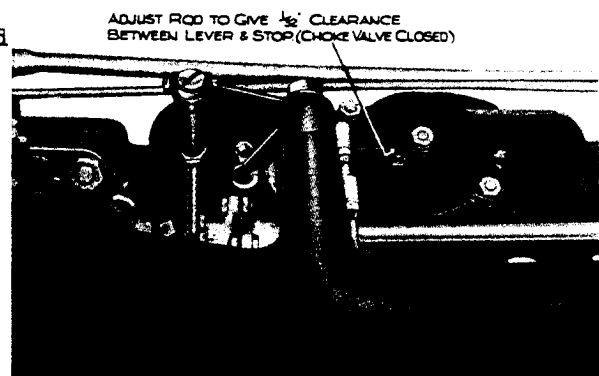


FIG. 1. ADJUSTMENT OF THERMOSTAT LEVER.

Bulletin

MODEL: BENTLEY MARK VI

- 2 -

TO RE-SET THE KICK DIAPHRAGM TRAVEL:

- (i) Undo the two 2 BA nuts retaining the choke valve assembly cover and remove the cover. (See Fig. 2).
- (ii) Adjust the travel of the kick diaphragm by means of the adjusting screw and a .090" drill or other suitable gauge placed at the apex of the choke valve as shown in Fig. 2. When pressing lightly on the choke valve, and pressing with a thin rod on the pivot end of the link rod to the diaphragm, the drill should be just free to move.

It will be appreciated that the adjusting screw acts as a stop to the diaphragm link rod; the further it is screwed out, the further can the link rod move backwards, thus determining the opening of the butterfly choke valve. It is essential, therefore, that the link rod is against its stop when taking the measurement at the butterfly apex.

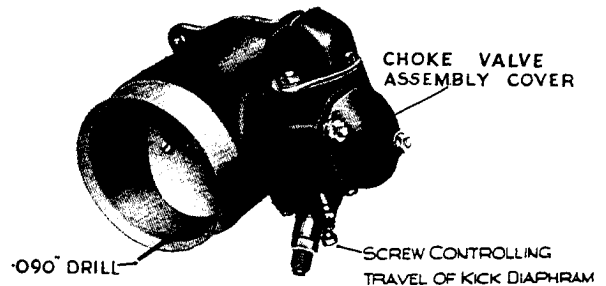
TO CHECK THE SOLENOID AIR GAP:

- (i) Proceed as in Fig. 3.
- (ii) Replace choke valve assembly cover.

2. CHOKE CONTROL OVER-RIDE MECHANISM:

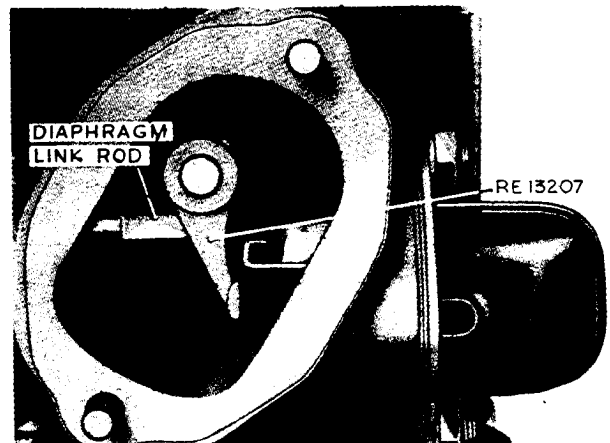
No provision was made on early automatic twin S.U. carburettors for clearing the system should flooding occur when starting from cold. It will be appreciated that the bi-metal spring and electric solenoid would hold the choke valve closed irrespective of the throttle position, and therefore, it would not be possible to turn the engine with choke and throttle open as is normally done on non-automatic systems.

An over-ride has been introduced on production whereby, when the throttle pedal is fully depressed, the choke valve is mechanically opened by trip levers. The alteration consists of fitting a new coupling shaft with a modified fast idle cam lever and a new fast idle cam link as shown in Fig. 4.



ADJ. KICK DIA DIAPHRAM TRAVEL TO ENABLE
 .090\"/>

FIG. 2. ADJUSTMENT OF KICK GAP.



LEVER & MAGNET COIL YOKE FACES MUST BE
 PARALLEL ONE TO ANOTHER WHEN IN POSITION
 GAP BETWEEN LEVER & YOKE FACES TO BE
 ADJUSTED TO .002/.006\"/>

FIG. 3. ADJUSTMENT OF SOLENOID AIR GAP.

Bulletin

MODEL: BENTLEY MARK VI

- 3 -

According to our records chassis numbers as listed on the attached sheet have not been fitted with an over-ride and should complaints occur of poor cold starting attributable to an initial excess of liquid fuel in the induction system, this modification should be carried out in conjunction with the modifications given above.

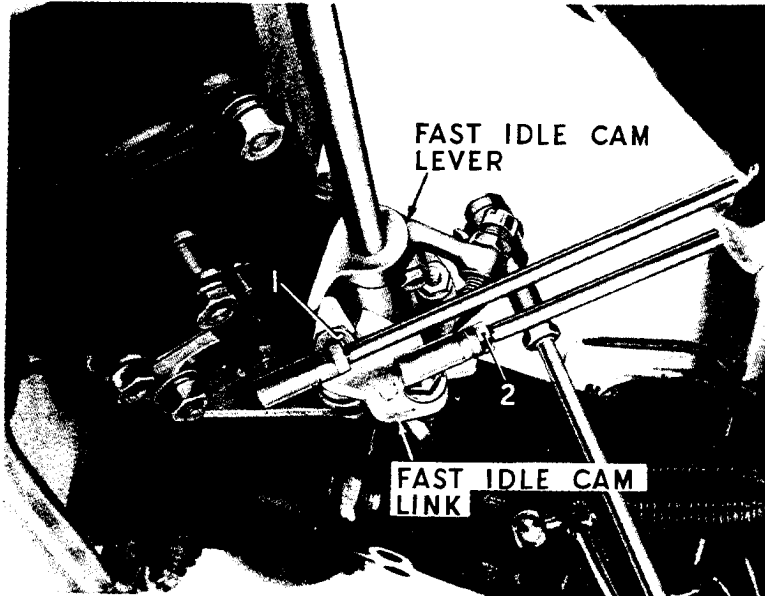


FIG. 4. THE NEW FAST IDLE CAM LEVER AND LINK.

Material Required:

<u>Part No.</u>	<u>Title.</u>	<u>No.Off.</u>
RE.19437	Assembly carburettor coupling shaft and fast idle cam lever.	1.
RE.19966	Assembly link fast idle cam.	1.
K. 8833	Washer- Spacing - Fast idle cam and link.	1.

These parts should be ordered from this Depot as required.

FITTING INSTRUCTIONS:

- (i) Remove the air filter for access to the carburettor linkage.
- (ii) Remove two 3 BA bolts from each of the couplings, RE.17012/17047, and lift out the coupling shaft, RE.17008 (Fig. 5).
- (iii) Loosen the pinch bolts and remove the half couplings from the shaft. Remove the locknut and screw from the fast idle cam lever. Assemble the half couplings on the new shaft, but do not tighten the pinch bolts.

Bulletin

MODEL: BENTLEY MARK VI

- 4 -

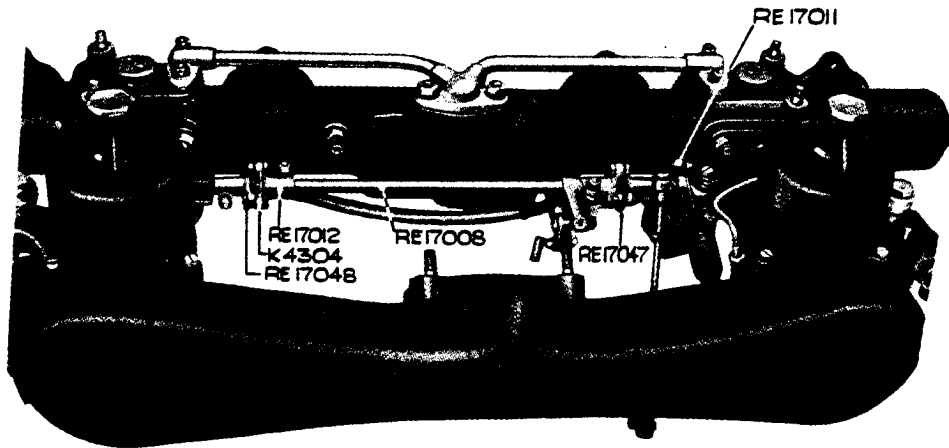


FIG. 5. CARBURETTERS ASSEMBLED.

- (iv) Undo the 2 BA nut holding the fast idle cam link on its pivot pin, (1, Fig. 4) and discard the 2 BA washer. It has been found that this washer may cause jamming of the fast idle cam link and fast idle cam and it should not be refitted. The 2 BA retention nut itself provides sufficient abutment for the link and cam. Undo the left-hand threaded 4 BA locknut at the lower end of the operating rod to the choke valve (2, Fig. 4). Remove the cam link and unscrew it (left-handed thread) from the rod.
- (v) Screw the new cam link to the rod and assemble it to its pivot pin, fitting the washer K.8833, between it and the fast idle cam so the washer rests in the counter-bore in the fast idle cam link. Secure with the 2 BA retention nut.
- (vi) Replace the new coupling shaft and re-assemble the couplings with the 3 BA bolts, nuts and washers.

TO RE-SET THE LINKAGE:

- (i) Screw back the throttle stop to allow the throttle to close fully.
- (ii) With the front carburettor throttle fully closed, tighten the front coupling pinch bolt to give .098" clearance between the fast idle cam and the cam lever (see Fig. 6). The cam lever adjusting screw hole should be central with the cam face.
- (iii) Hold the rear carburettor throttle closed and tighten the rear coupling pinch bolt.
- (iv) Adjust the throttle stop screw to open the throttles $\frac{1}{2}$ turn from the fully closed position.

Bulletin

MODEL BENTLEY MARK VI

- 5 -

- (v) Fit the screw and locknut to the fast idle cam lever and with the screw nose resting on the high stop of the fast idle cam, adjust the screw (RE.17013) to give .030" clearance between the throttle stop and the throttle lug. (See Fig. 7).
- (vi) Adjust the rod from the fast idle cam link to the choke valve as shown in Fig. 7.
- (vii) Warm up the engine and set the idling for mixture and speed.
- (viii) With the engine cold, re-set the fast idle cam screw RE.17013 to give .030" clearance between the throttle stop screw and lug as in paragraph (v).

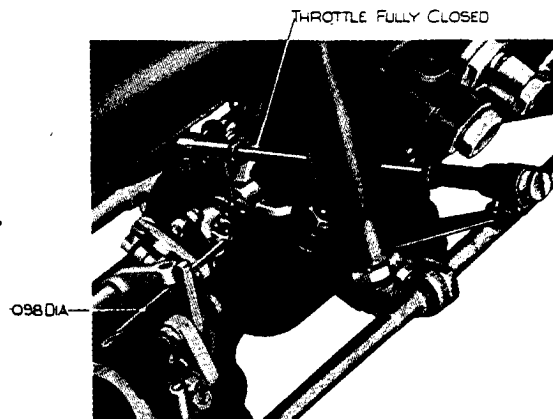


FIG. 6. FAST IDLE CAM AND LEVER ADJUSTMENT.

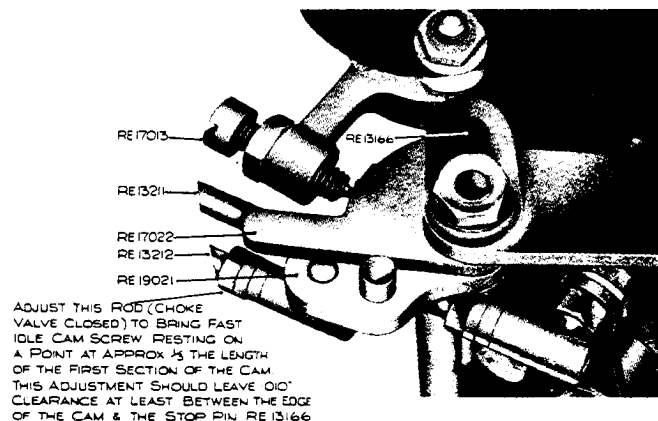


FIG. 7. SETTING THROTTLE STOP.

It is essential that the fast idle cam and link are perfectly free and that no undue scrubbing takes place between the two. The opportunity should be taken to check this free action. No oil or grease should be used on the assembly, but it is permissible lightly to file the outer face of the fast idle cam link to increase clearance.

Similarly, should there be a foul between the new fast idle cam link and the fast idle cam stop, (RE.13166, Fig. 7), the cam stop may be filed on its outer end.

Minimum end clearance for cam and link is .015".

Bulletin

MODEL BENTLEY MARK VI

AUTOMATIC S.U. CARBURETTOR MODIFICATIONS.

There is no record of the following cars having been fitted with the over-ride choke control, although some may have been modified.

<u>CHASSIS NO.</u>	<u>CHASSIS NO.</u>	<u>CHASSIS NO.</u>	<u>CHASSIS NO.</u>
B 8 LRT	B 10 RT	B 14 RT	B 18 RT
B 20 RT	B 22 RT	B 26 LRT	B 32 RT
B 34 LRT	B 38 RT	B 42 RT	B 44 RT
B 46 LRT	B 48 LRT	B 50 RT	B 52 LRT
B 54 RT	B 56 RT	B 64 RT	B 66 RT
B 70 LRT	B 72 RT	B 74 RT	B 76 RT
B 78 RT	B 80 LRT	B 82 RT	B 84 RT
B 86 RT	B 88 RT	B 90 RT	B 92 RT
B 94 RT	B 96 RT	B 98 LRT	B 100 RT
B 106 RT	B 108 RT	B 110 RT	B 112 RT
B 114 RT	B 116 RT	B 118 RT	B 120 RT
B 1 RS	B 3 RS	B 7 RS	B 9 RS
B 11 RS	B 15 RS	B 17 RS	B 19 RS
B 21 RS	B 23 RS	B 27 RS	B 29 RS
B 31 RS	B 33 RS	B 35 RS	B 37 RS
B 39 RS	B 41 RS	B 43 RS	B 45 RS
B 47 RS	B 49 RS	B 51 RS	B 53 RS
B 55 RS	B 57 RS	B 59 RS	B 61 RS
B 63 RS	B 65 RS	B 67 RS	B 69 RS
B 71 RS	B 73 RS	B 75 RS	B 77 RS
B 81 RS	B 83 RS	B 87 RS	B 89 RS
B 95 LRS	B 97 RS	B 99 RS	B 101 RS
B 103 RS	B 105 RS	B 109 RS	B 113 RS
B 115 RS	B 119 RS		
B 4 SR	B 6 SR	B 8 SR	B 10 SR
B 14 SR	B 16 SR	B 24 SR	B 26 LSR
B 28 SR	B 30 LSR	B 32 LSR	B 34 LSR
B 38 SR	B 44 SR	B 46 SR	B 50 SR
B 54 SR	B 58 SR	B 62 SR	B 64 SR
B 68 SR	B 74 SR	B 80 SR	B 82 SR
B 84 SR	B 90 SR	B 92 SR	B 94 SR
B 96 SR	B 102 SR	B 104 SR	B 130 SR
B 176 SR	B 316 SR	B 320 SR	B 322 SR
B 324 SR	B 326 SR	B 328 SR	B 330 SR
B 332 SR	B 334 SR	B 338 SR	

FOR INFORMATION.AUTOMATIC TWIN S.U. INDUCTION SYSTEMDESIGN MODIFICATIONS.

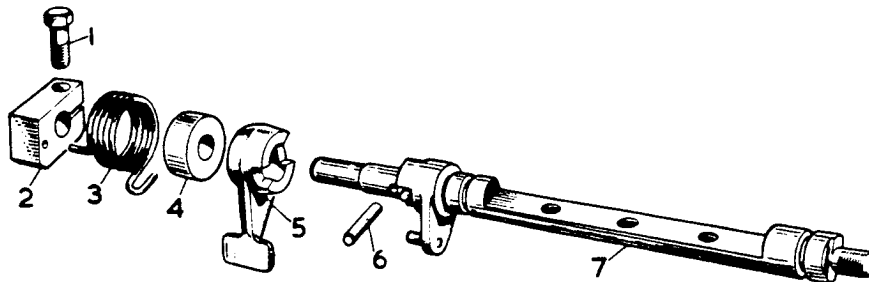
This Bulletin gives advance information of design improvements to the Automatic Twin S.U. Induction System which will shortly be incorporated on production.

1. OIL PRESSURE SOLENOID SWITCH.

In order to ensure more positive starting with a cold engine it has been found necessary to delay the initial opening of the choke valve.

With the present automatic system the choke valve is held in the fully closed position by an electric solenoid wired in parallel with the starter button. As soon as the engine fires the starter button is released and the solenoid releases the choke valve. It has been found that, at this point, the choke valve flies open violently, due to the depression created in the manifold by initial cranking, and continues to oscillate a few times before settling down in the position determined by the kick diaphragm travel. This sudden opening of the choke can be sufficient to stall a cold engine at the first attempt to start.

The difficulty has been overcome by delaying the solenoid circuit break for some 5 to 7 seconds after the engine commences to run by wiring the solenoid in parallel with the ignition circuit and using an oil pressure sensitive switch to break the circuit at a given oil pressure.



- | | |
|----------------------|------------------------------|
| 1. Clamping Screw. | 5. Solenoid Lever. |
| 2. Spring Tensioner. | 6. Pin. |
| 3. Spring. | 7. Choke Valve Spindle Assy. |
| 4. Bush. | |

FIG.1 EXPLODED VIEW OF CHOKE VALVE SPINDLE.

At the same time to prevent over-choking, the solenoid lever has been spring-loaded to the choke valve spindle (Fig.1), thereby allowing the manifold depression to open the choke valve against the spring loading whilst the solenoid is in operation. The pre-loading of the spring is adjusted so that the maximum opening of the choke valve in this way is 5° , experience having shown this to be the maximum opening to ensure a cold engine's running at the first application of the starter.

Bulletin

MODEL BENTLEY MARK VI
- 2 -

As soon as the oil pressure reaches 15 lbs/sq.in. the switch breaks the solenoid circuit and the choke valve is pulled open a further 5° by the kick diaphragm operated by manifold depression.

The oil pressure switch is fitted between the pump and the full-flow filter to ensure a quick response and uses the existing plugged outlet in the oil feed adaptor (Fig.2). The solenoid is now a two pole unit and although energised whenever the oil pressure falls below 15 lbs/sq.in. its magnetic strength is only sufficient to close the choke valve when the valve is already within 5° of that position. Fig.3 shows a wiring diagram for the new arrangement.

In order to maintain the choke over-ride system for clearing any initial flooding, the choke valve spindle pin (Fig.1) is allowed 30° of free travel in the solenoid lever. Thus the choke valve can be opened 30° by fully depressing the accelerator pedal even though the magnetic lock of the solenoid is in force.

2. NEW FAST IDLE CAM ARRANGEMENT.

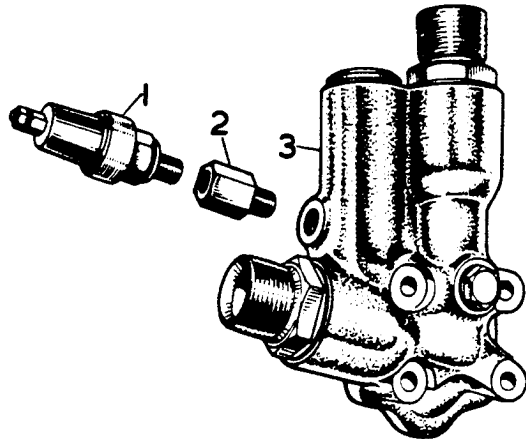
A new fast idle cam link, support bracket and fulcrum pin have been introduced to prevent scrubbing between the cam link and the fast idle cam. The fast idle cam has also been re-designed to give reduced speeds on the intermediate steps and a shorter duration for the whole fast idle stage. (Fig.4).

3. SETTINGS.

The following settings are required where the new system is fitted:

(1) Kick Diaphragm Travel.

The Kick Diaphragm travel should be set to .075" (1.90 mm). The setting is measured with a drill between the choke valve and the choke body as detailed in Bulletin BB-165 dated 29.1.53.



1. Switch. 2. Adaptor. 3. Oil Feed Adaptor.

FIG.2 OIL PRESSURE OPERATED SWITCH AND OIL FEED ADAPTOR

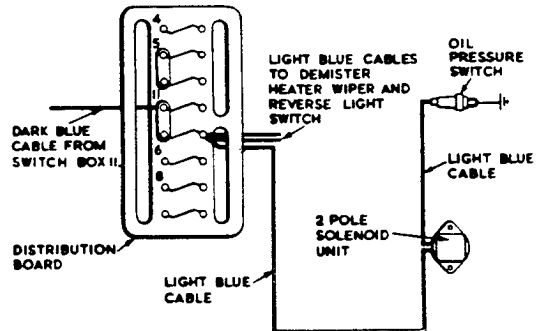
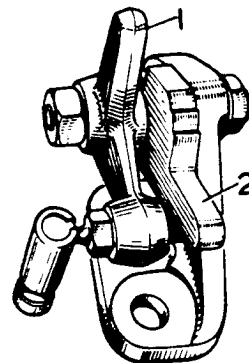


FIG.3 WIRING DIAGRAM.



1. Fast Idle Cam Link. 2. Fast Idle Cam.

FIG.4 NEW FAST IDLE CAM AND LINK.

Bulletin

MODEL: BENTLEY MARK VI

(ii) Solenoid Air Gap.

The solenoid air gap is set to between .0005" and .004" (.012 and .10 mm). It is adjusted by shims under the solenoid flange as detailed in Bulletin BB165 dated 29.1.53.

(iii) Spring Tensioner Setting.

The spring tensioner should be set so that a weight of 235 to 240 grammes acting on an arm of 2" (50.8 mm) length will open the choke valve just sufficiently to allow a .062" (1.51 mm) drill to be inserted between the edge of the valve and the body, (Fig.5).

Having set the kick diaphragm travel and solenoid air gap the housing should be mounted in a vice by two $\frac{1}{4}$ " bolts and nuts fitted to the retention flange holes. Connect up a 12 volt battery to energise the solenoid and adjust the spring tensioner on the spindle so that the weight opens the choke valve the required amount.

▲ single tool combining the lever and weight is being designed by the Service Department.

(iv) Fast Idle Setting.

After setting the mixture and slow running in the usual way the fast idle should be adjusted whilst the engine is still warm. Adjust the fast idle screw on the highest step of the fast idle cam to give .035" (.89 mm) clearance between the throttle stop screw and its stop.

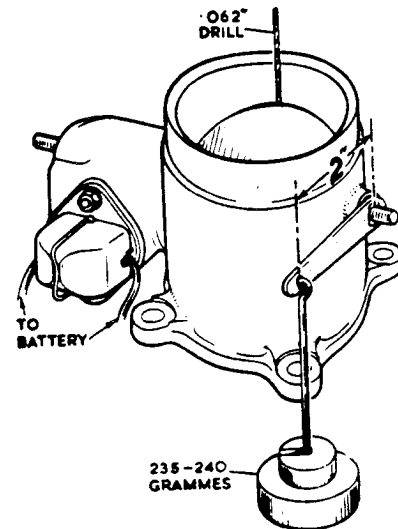


FIG.5 SETTING THE SPRING TENSIONER.



MODEL BENTLEY MARK VI

AUTOMATIC TWIN S.U. INDUCTION SYSTEMDESIGN MODIFICATIONS.

Service Bulletin BB-188 gave advance information of design improvements to the Automatic Twin S.U. Induction System that will shortly be incorporated on production. A further new feature to be introduced at the same time is described below.

4. BI-METALLIC SOLENOID SWITCH.

Additional experience has shown that the positive lock of the choke valve in the closed position, provided by the solenoid unit, is not necessary for starting when the under-bonnet temperature is more than approximately 15°C.

A bi-metallic switch has therefore been introduced into the solenoid circuit between the distribution board and the solenoid unit to break at 15°C. The switch is mounted on the conduit elbow on the right hand side of the dashboard below the fuse box. It re-closes the circuit when the under-bonnet temperature falls to 10°C.

With this switch, the Automatic System ensures a fully closed choke for cold starting but avoids any tendency to over-richness when starting with the engine warm or hot.

Bulletin

MODEL : BENTLEY MARK VI

FOR INFORMATIONMODIFICATIONS TO THE AUTOMATIC TWIN S.U.INDUCTION SYSTEM

Service Bulletins BB-188 and BB-188A gave advance information of modifications to the Automatic Twin S.U. Induction System that are now being fitted on production. Details for modifying earlier cars to the latest specification are given for information in the following paragraphs. It is not intended that the modifications should be retrospective and Retailers should carry them out only after consultation with the London Service Station to meet complaints of poor cold starting.

Parts Required:

R.5304	Assy. Automatic Choke	1 Off.
RE.21918	Assy.Bkt.Support - Fast Idle Cam	1 Off.
RE.21908	Assy.Link - Fast Idle Cam	1 Off.
RE.21735	Fast Idle Cam	1 Off.
UE.514	Fulcrum Pin	1 Off.
RE.21917	Oil Pressure Switch	1 Off.
RE.21688	Adaptor - Oil Pressure Switch	1 Off.
UD.1819	Bi-Metal Switch	1 Off.
K.2801/Z	Mounting Screws	2 Off.
K.9006/Z	Spring Washers	2 Off.
K.4006/Z	Nuts	2 Off.
16/.012	P.V.C. Cable - Light Blue	2 Feet.
16/.012	P.V.C. Cable - Beige	2 Feet.
RD.3533	Cable Eyes 2 B.A.	2 Off.
RD.3690	Cable Eyes 3 B.A.	1 Off.
RD.3106	Rubber Elbow Sleeving	3 Off.
	Sleeving P.V.C. 5 m/m - Black	3 Feet.

The Automatic Choke Assembly supplied will have the spring tensioner on the spindle, the solenoid air gap and the kick diaphragm travel correctly set.

Procedure:

- (i) Remove the air cleaner.
- (ii) Undo the 2 BA nut retaining the choke lever on the choke valve spindle and remove the choke lever. Disconnect the feed wire to the choke solenoid. Remove the four nuts and spring washers retaining the bottom flange of the automatic

ALL COMMUNICATIONS SHOULD BE ADDRESSED TO
BENTLEY MOTORS (1931) LTD, SERVICE STATION, HYTHE ROAD, WILLESDEN, LONDON, N.W.10

SECTION

Bulletin

MODEL: BENTLEY MARK VI
- 2 -

choke assembly to the air intake duct and remove the choke assembly. Fit the new assembly.

- (iii) Undo the 2.B.A. nut securing the fast idle cam and link to the fulcrum pin. Remove the cam and link and unscrew (left hand thread) the ball joint of the cam link from the link rod. Remove the fast idle cam bracket by undoing the two securing nuts. Screw the new cam link assembly to the link rod.
- (iv) Fit the new fulcrum pin to the new cam bracket with a 2.B.A. nut and spring washer removed from the old assembly. Fit the bracket to its flange on the induction manifold.
- (v) Refit the new fast idle cam and link to the fulcrum pin and fit a 2.B.A. retaining nut. No washer is required. Adjust the thermostat link rod to give $\frac{1}{32}$ " clearance between the thermostat lever and its stop pin as shown in Fig.1. Adjust the fast idle cam link rod so that with the choke valve closed the fast idle screw rests at a point approximately $\frac{1}{3}$ the way along the first step of the cam.

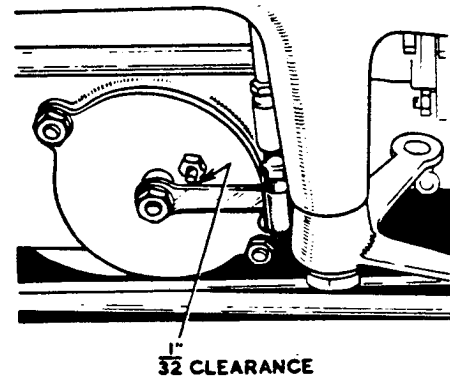


FIG.1.
ADJUSTMENT OF THERMOSTAT LEVER.

It may be found that the fast idle screw does not rest centrally on the fast idle cam steps and that it is necessary to reposition the carburetter coupling shaft and fast idle screw lever. Undo the pinch bolts securing the couplings at each end of the shaft and push the shaft forward so that the fast idle screw is centrally positioned over the fast idle cam. Re-set the shaft as follows:-

- (a) Screw back the throttle stop screw to allow the throttles to close fully. Remove the fast idle screw and locknut from its lever.
- (b) With the front carburetter throttle fully closed, tighten the front coupling pinch bolt to give $.098$ " (2.5 m/m) clearance between the fast idle lever and the cam (Fig.2.). The adjusting screw hole in the lever should be central with the cam face.
- (c) Hold the rear carburetter throttle closed and tighten the rear coupling pinch bolt.
- (d) Adjust the throttle stop screw to open the throttles $\frac{1}{2}$ turn from the fully closed position.

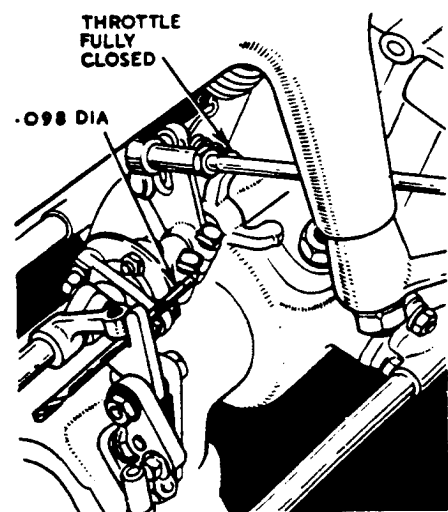


FIG.2.
RE-SETTING THE COUPLING SHAFT.

ALL COMMUNICATIONS SHOULD BE ADDRESSED TO
BENTLEY MOTORS (1931) LTD., SERVICE STATION, HYTHE ROAD, WILLESDEN, LONDON, N.W.10

Bulletin

MODEL: BENTLEY MARK VI

- 3 -

- (e) Fit the adjusting screw and locknut to the fast idle lever and with the screw nose resting on the high step of the cam, adjust the screw to give .035" (.9 mm) clearance between the throttle stop screw and its lug.
- (vi) Remove the conduit elbow from the dashboard underneath the distribution board and drill the two holes as shown in (Fig.3). Drill and cut out the slot as shown. Fit the bi-metallic switch on the outside of the conduit elbow.

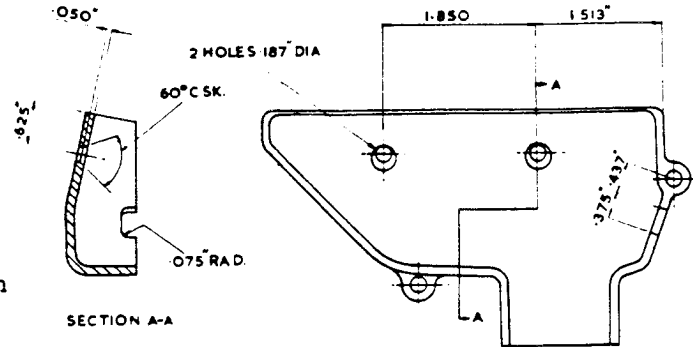
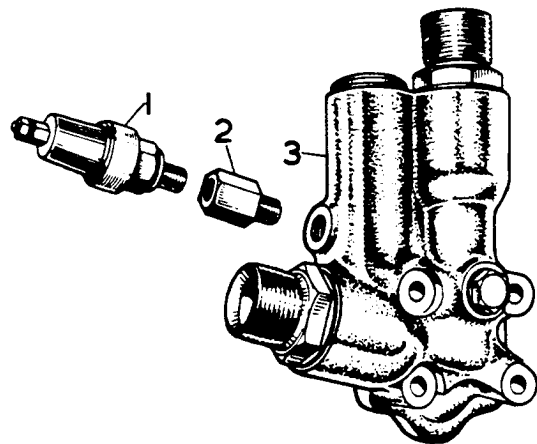


FIG.3.
DRILLINGS AND SLOT IN CONDUIT ELBOW.

- (vii) Remove the blanking plug and fit the oil pressure switch and adaptor to the oil feed adaptor as shown in (Fig.4). If the feed to the oil pressure gauge is taken from this upper connection, remove the flexible pipe and refit to the central forward connection which will have a blanking plug.
- (viii) Remove the existing beige feed wire to the solenoid from the triangular shaped 12 way junction box on the dash. The wire leaves the junction box and passes down the dash in the main loom under the conduit, leaving the main loom at the valve to lead to the solenoid switch. Pull the wire down to the top of the conduit and arrange it to pass out through the slot in the conduit elbow to the left hand connection on the bi-metal switch. Cut the cable to length. Run a cable from the distribution board out through the slot in the elbow to the right hand terminal (Fig.5.) Cover exposed cable with P.V.C. sleeve. Refix the conduit elbow to the dash and connect the cables to the switch with 2.B.A. cable eyes and rubber elbow sleeves. (It will be noted



1. Switch. 3. Oil Feed Adaptor.
2. Adaptor.

FIG.4.
OIL PRESSURE OPERATED SWITCH AND OIL FEED ADAPTOR.

Bulletin

MODEL: BENTLEY MARK VI

- 4 -

that the feed is now taken from the main ignition circuit and not from the auxiliary circuit as shown in the wiring diagram in Bulletin BB-188.)

- (xiv) Connect the solenoid to the oil pressure switch with light blue cable in 5 m/m sleeving. A J.B.A. cable eye and rubber elbow sleeve should be fitted at the oil pressure switch connection. Refit the beige cable to the solenoid.
- (x) After tuning the carburetters in the normal way the fast idle should be set whilst the engine is still warm. Adjust the fast idle screw on the highest step of the cam to give .035" (.89 m/m) clearance between the throttle stop screw and its stop.

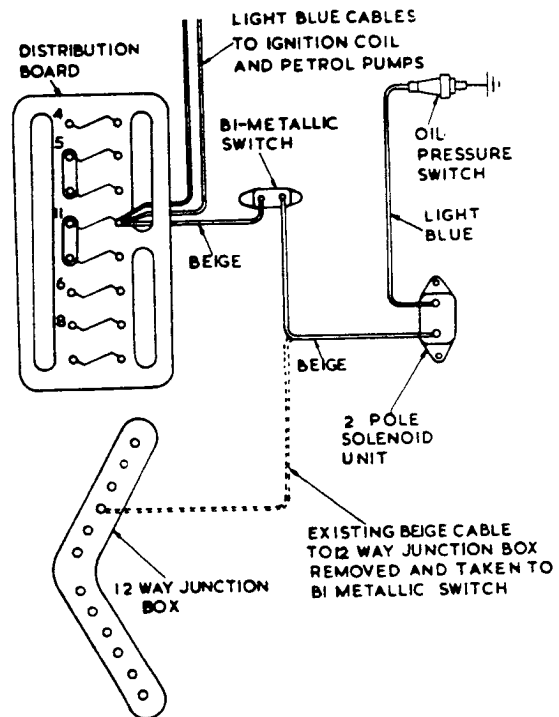


FIG. 5.
WIRING DIAGRAM.

The replaced Automatic Choke Assembly should be returned to the London Service Station.



MODEL BENTLEY MARK VI

FOR INFORMATION:

AUTOMATIC TWIN S.U. INDUCTION SYSTEM.

CHOKE SOLENOID (ELECTRO MAGNET)

There are two types of solenoids as below:-

- a) A single pole type, RD-6501, fitted to earlier chassis having the automatic choke control.
- b) A double pole type, RD-8574, as at present fitted in conjunction with the oil pressure switch incorporated in the solenoid circuit.

When the existing stock of the single pole solenoids (RD-6501) are used up and where it is necessary to renew a single pole type, a converted double pole type (Fig.3) will be supplied. Referring to Fig.3, it will be noted that the unit has been modified by removing one end of the electro magnetic winding (C) from its terminal (B) and earthing it by soldering to the base plate.

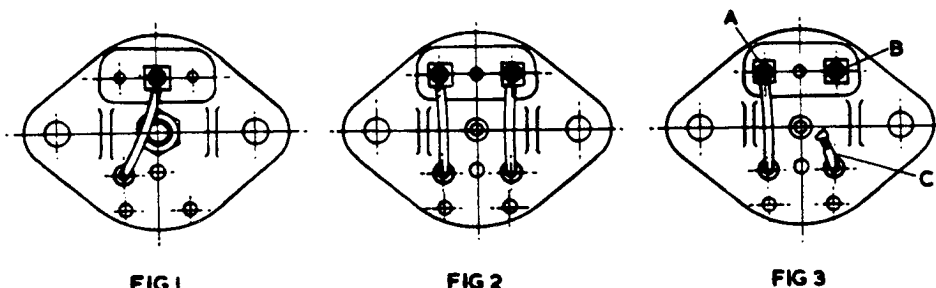
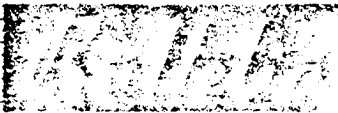


Fig.1. shows a rear view of the single pole type.
 Fig.2. " " " " " " double pole type.
 Fig.3. " " " " " " (double pole type converted to the single pole type.)

The existing beige coloured cable from the 12-way junction box should be connected to the terminal A (Fig.3) when fitting a modified solenoid to the engine.

On chassis already fitted with a double pole unit, an RD-8574 unmodified type will of course be required when renewal is necessary.



A. D. I. BENTLEY MARK VI

OVERFLOW PIPE - FRONT CARBURETTERBENTLEY MARK VI - A TO M SERIES INCLUSIVE.

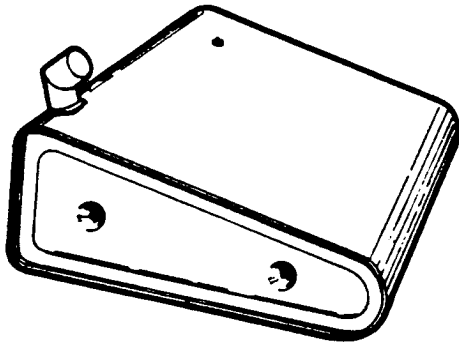
The overflow pipe for the float chamber of the S.U. carburetter has a banjo connection which is retained by the centre bolt passing through the float chamber cover. On Bentley Mark VI Models, from A to M Series inclusive, it is essential that the overflow pipe for the front carburetter is positioned to run down the outside of the float chamber. The lower end of the pipe should be bent outwards away from the dynamo brush gear.

It is known that some models in these series have the overflow pipe positioned to run down the inner, engine side of the float chamber, allowing excess petrol to drip onto the rear end of the dynamo if flooding occurs.

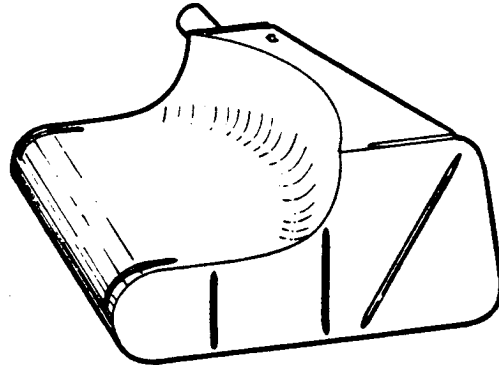
Retailers are asked to check cars during service and to re-position the pipe where necessary.

FOR INFORMATION.PETROL GAUGE FLOAT UNITSBENTLEY 'R' TYPE.

Some confusion has arisen in ordering replacement petrol gauge float units for the Bentley 'R' Type as Coachbuilders, with the exception of Messrs Hooper Ltd., have continued to use the earlier Mark VI flat type tank on the 'R' Type chassis. All 'R' Type standard Steel Saloons and coachbuilt models by Messrs Hooper Ltd., have an 'L' shaped tank. The two tanks are shown in the illustration.



MK.VI TYPE TANK



'R' TYPE TANK

Retailers are asked particularly to check which tank is fitted before ordering replacement float units. Part numbers of the units are as follows :

RF.5410 Gauge, electric - for Mark VI Flat Tank

RF.9227 Gauge, electric - for 'R' Type 'L' shaped Tank.

FOR INFORMATION:

UNIVERSAL AUTOMATIC TRANSMISSION.

T.V. Control Settings for L.H. and R.H. Bentley.

Refer to either Fig.I (for R.H. cars) or Fig.II (for L.H. cars).

1. Set the hot idle to 350-375 r.p.m. in "4" range.
2. Disconnect rods A and B.
3. With the carburettor in the hot idle position (fast idle cam out of action), adjust rod C until lever D is positioned to the gauge.

DIAGRAMATIC LAYOUT OF T.V. CONTROL LINKAGES
R.H. BENTLEY, DAWN AND WRAITH.

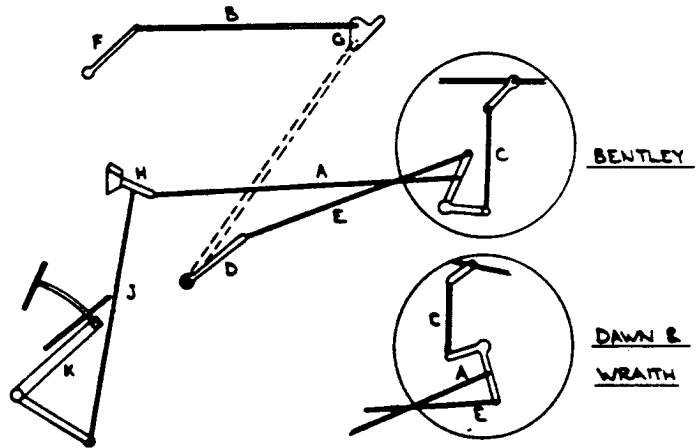


FIG. I.

DIAGRAMATIC LAYOUT OF T.V. CONTROL LINKAGES
L.H. BENTLEY, DAWN AND WRAITH.

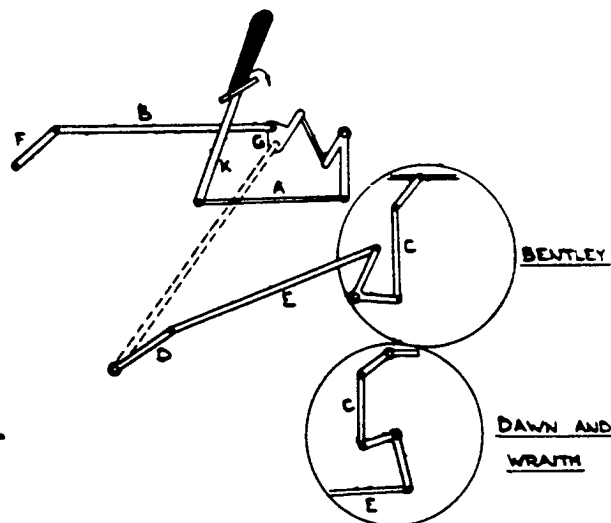


FIG. II.

Bulletin

MODEL BENTLEY MARK VI

- 2 -

(i) Gauge Setting Instructions R.H. cars - refer to Fig.III.

A suitable gauge (ZX.757) is required. This locates on the distance piece behind the lever D and on the face (Q, Fig.III) of the flywheel front casing which projects below the bottom of the crankcase.

Adjust rod C until the extended end of rod E just rests on or is up to 1/16" above the top edge of the gauge (edge P, Fig.III).

(ii) Gauge Setting Instructions L.H. cars - refer to Fig.IV.

A suitable gauge (ZX.636) is required. This locates on the distance piece behind the lever D and on the top of the starter motor 'S'.

Adjust rod C as above.

GAUGE POSITION FOR SETTING LEVER 'D'
R.H. BENTLEY, DAWN AND WRAITH

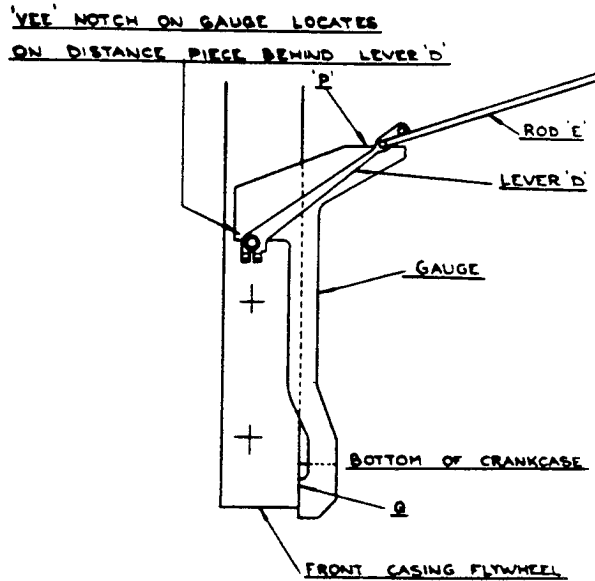


FIG. III.

GAUGE POSITION FOR SETTING LEVER 'D' - L.H. BENTLEY, DAWN & WRAITH

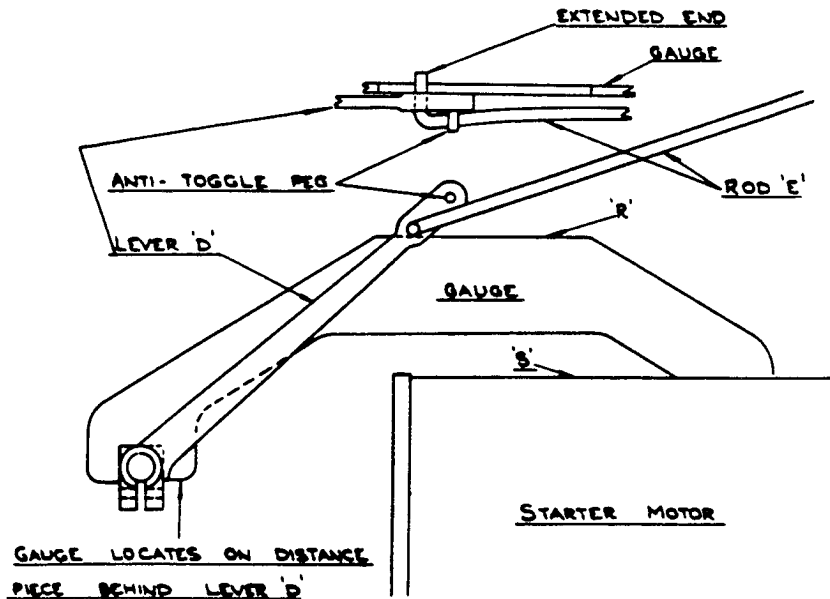


FIG. IV.

ALL COMMUNICATIONS SHOULD BE ADDRESSED TO
BENTLEY MOTORS (1931) LTD. SERVICE STATION, HYTHE ROAD, WILLESDEN, LONDON, N.W. II

- 3 -

4. Hold lever F in the forward direction to the limit of its travel.
5. Adjust rod B until it will just slip into the hole in lever G; (if two holes are present in lever G, the hole nearest the front of the car should be used).
6. For R.H. and L.H. Bentley, make rod B 4 turns longer.
7. Adjust the pedal. NB. On no account should rod C be used for pedal adjustment.

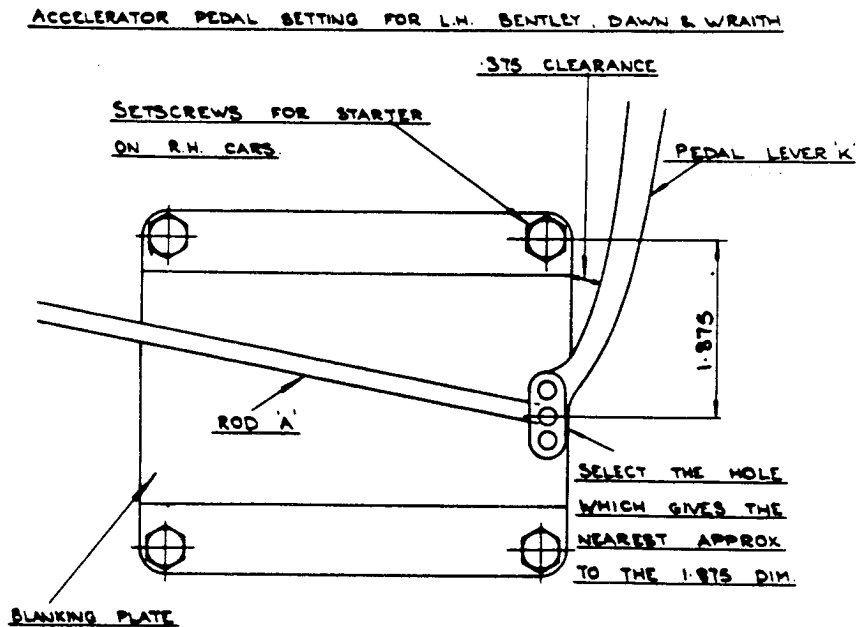


FIG. V.

R. H. Cars

- (i) Adjust rod A until lever H makes an angle of 75-80° with the face of the dash (lever to lie below the horizontal).
- (ii) Adjust rod J so that in the full throttle position the rubber stops on the pedal stem just clear the toe board.

- 4 -

Setting Instructions for Manual Gear Controls
(including Micro Switches) on all RH Cars.

1. Disconnect the control rod which connects the lever on the cross shaft to the lever on the control tube.
2. Set the gearbox in neutral (i.e., lever on the gearbox in the extreme forward position).
3. Adjust the length of the control rod which connects the gearbox lever to the lever on the cross shaft until the lever on the cross shaft on the R.H. side of the car projects .500" (approx.) below the level of the frame.
4. With the quadrant and gearbox lever in neutral, adjust the length of the control rod (connecting the lever on cross shaft to that on the control tube) until the 2 BA bolt at the lower end will just pass through the jaw and rubber bush. (Ensure that the distance piece in the rubber bush does not drop out while the rod is disconnected).
5. Check the quadrant in all positions. The correct position for each gear can be felt by the detent in the gearbox. The linkage is set correctly if in the "4" position the lever rests just clear of the "neutral stop". Similarly in the "3" position the lever should rest just clear of the "gate stop".

Any fine adjustments that may be required to obtain these latter conditions should be made on the rod from the control tube to the cross shaft.

6. Set the micro switches.

The switches are adjusted by means of slotted holes in the mounting bracket.

If the micro switch button is pressed, a certain amount of free movement will be noticed before the switch operates. This free movement should be taken up when setting to the following instructions.

- (i) Starter Switch (nearer the engine).
 - a) Set the quadrant in position "3".
 - b) Adjust the position of the switch until the clearance between the operating peg and the switch button is .156" (approx.).
- (ii) Reversing Light Switch.
 - a) Set the quadrant in position "2".
 - b) Adjust the position of the switch until the clearance between the operating peg and the reverse switch button is .125 (approx.).

- 5 -

Setting Instructions for Manual Gear Controls
(including micro switches) on all LH Cars.

1. Disconnect the vertical control rod which connects the lever on the control tube to the intermediate plate lever.
2. Set the gearbox in neutral (i.e., lever on the gearbox in the extreme forward position).
3. Adjust the length of the horizontal control rod which connects the gearbox lever to the intermediate plate lever to $17\frac{3}{4}$ " from ball centre to pin centre.
4. With the quadrant and gearbox lever in neutral, adjust the length of the vertical control rod until it is the required length.
5. Check the quadrant in all positions. The correct position for each gear can be felt by the detent in the gearbox. The linkage is set correctly if in the "4" position the lever rests just clear of the "neutral stop". Similarly in the "3" position the lever should rest just clear of the "gate stop".

Any fine adjustments that may be required to obtain these latter conditions should be made on the vertical rod.

6. Set the micro switches.

The lower of the two is the starter switch, the upper one the reversing light switch.

The switch mechanism is adjustable at two points:

- (i) by a slotted hole enabling the pivot point of the rocking lever to be moved nearer to or away from the switches.
- (ii) by a slotted hole which enables the operating fork to be set at different angles relative to the operating tube.

If the micro switch button is pressed, a certain amount of free movement will be noticed before the switch operates. This free movement should be taken up when setting to the following instructions:

- a) Set the quadrant in position 2.
- b) Pivot the rocking lever until the free movement is taken up in the reversing light switch.
- c) Adjust the position of the rocking lever pivot until the clearance between the lever and the starter switch button is .075" (approx.).
- d) With the rocking lever still in the above position, adjust the position of the operating fork until the clearance between the operating tab on the engine side of the rocking lever, and the rocking lever is .125" (approx.).

FOR INFORMATION

. PETROL PUMPS.

Due to the use of high-alcohol content fuels, causing the diaphragm of the petrol pump to swell and the consequent loss of armature travel, it has been found necessary to revise the "Setting Instructions" given in the Workshop Manual.

These instructions state that when setting the diaphragm,

"Unscrew the diaphragm one sixth of a turn (one flange hole) at a time until a point is reached when on pressing the centre of the diaphragm the outer rocker will toggle-over. Unscrew the diaphragm a further two thirds of a turn (four holes) to obtain the correct setting."

The above should be revised to read :-

"Unscrew the diaphragm one sixth of a turn (one flange hole) at a time until a point is reached when on pressing the centre of the diaphragm the outer rocker will toggle-over. Unscrew the diaphragm a further full turn (six holes) to obtain the correct setting."