

**Bulletin**

MODEL BENTLEY MARK VI

**MODIFICATION.****REAR BRAKE EQUALISER.**

A certain number of cars were built with the rubber support of the rear brake equaliser fitted and positioned whilst in the chassis stage of production. When the body is mounted, the effect of its weight on the geometry of the rear suspension causes distortion of the support which may lead to fracture; repositioning of the support is therefore necessary in some cases.

Examination for signs of fracture, and if necessary, repositioning on the equaliser bar should be carried out on Bentley VI cars as follows:-

B-AK and B-AJ Series. Chassis Nos.....All cars.

B-BH Series. Chassis Nos.....Up to No.B220BH on cars fitted with Standard saloon body.

Chassis Nos.....Up to No.B138BH on cars fitted with custom built body.

The attached drawing and following procedure give the necessary information required for carrying out the examination and repositioning of the rubber support.

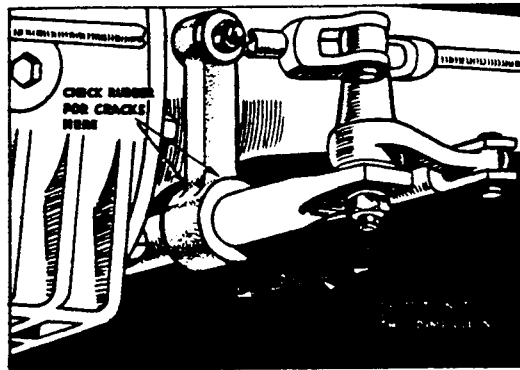

1. Disconnect the rubber support from the axle tube and flex it backwards and forwards so as to examine for cracks in the neck at the junction with the main boss. If there are any signs of cracks, replace with a new support.
2. Check that the rear face of the main boss is 2.275 ins. from the centre of the rear brake equaliser bolt, and reposition if necessary.
3. Paint the letter 'E' on the rear face halfway down the rubber leg after examination and repositioning.

All Retailers are requested to contact the owners of the cars affected in their respective areas as soon as possible, with a view to taking corrective action, and to notify this Service Depot concerning chassis numbers of individual cars dealt with under this procedure.

ALL COMMUNICATIONS SHOULD BE ADDRESSED TO

BENTLEY MOTORS (1931) LTD. SERVICE STATION, WYTHE ROAD, WIMBORNE, DORSET.

**Bulletin**

MODEL: BENTLEY MARK VI

MODIFICATION.

CATEGORY 3A

ALTERATION TO BRAKE LINKAGE ADJUSTMENT

A modification is introduced to reduce a mechanical noise that can more accurately be described as a "clonk" from the brake linkage which may occur on application of the brakes.

In many cases, the origin of this noise has been traced to excessive free travel between the plunger and piston of the brake master cylinder, and adjustment of the brake linkage as described hereunder, has in certain instances effected a noticeable reduction of the noise.

The attached drawing shows the linkage involved in carrying out this adjustment:-

1. Ensure that the rear brakes are in the OFF position and that the lever 'R' is against its OFF stop.
2. Remove the master cylinder pull-off spring 'X' and the clevis pin 'D'
3. Adjust the rod 'C' so that the joint 'J' has zero to .050" free travel before the plunger 'M' contacts the master cylinder piston.
4. Tighten the locknut on the rod 'C'. Replace the clevis pin 'D' and the master cylinder pull-off spring 'X'.

# Bulletin

MODEL: BENTLEY MARK VI

- 2 -

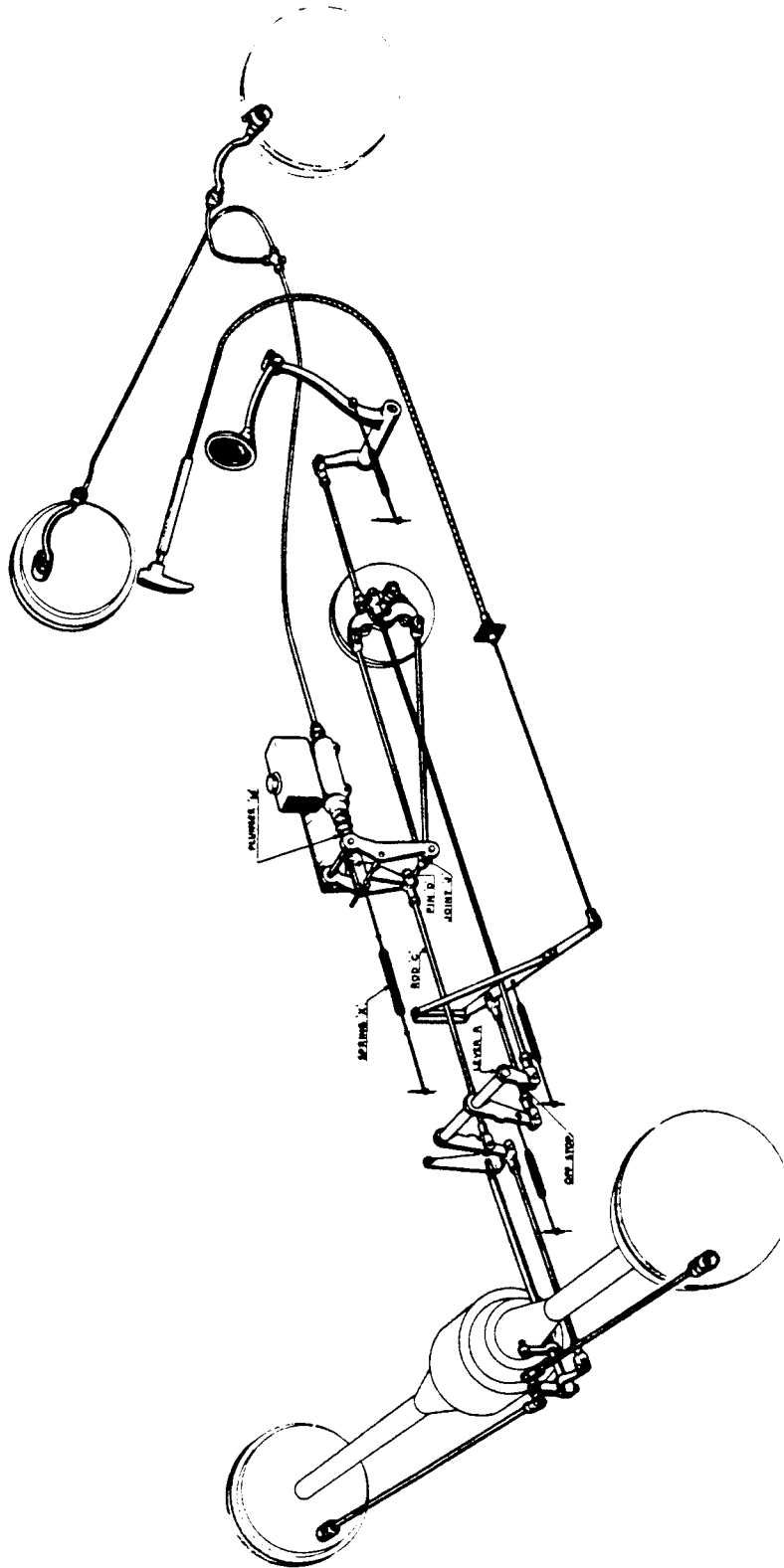

ALL COMMUNICATIONS SHOULD BE ADDRESSED TO  
 BENTLEY MOTORS (1931) LTD. SERVICE STATION, HYTHE ROAD, WILLESDEN, LONDON, N.W.11

The logo for Bentley Bulletin, featuring the word "Bulletin" in a stylized, cursive font on a dark, textured background.

MODEL BENTLEY MARK VI

FOR CATEGORY 2 ACTION.S E R V O.

For the time being, and until further notice, Retailers and Depots are requested to check for tightness the hexagon headed bolt which passes through the centre of the servo shaft. The head of the bolt is at the extreme end of the servo motor, and is quite accessible from beneath the car.

The purpose of the check is to ascertain whether any form of locking device is necessary. Therefore, will Retailers and Depots inform us whether any securing bolts are found loose when cars come in for normal servicing.

MODIFICATION TO EQUAL WEAR LINKAGEFRONT BRAKES.FOR INFORMATION:

Instances have occurred in service with the Bentley Mark VI, where the front brakes have failed to release properly after application. This "Spragging" of the front brakes is due to an excessive self-servo action of the shoes, and manifests itself by a locking of the brakes even after the foot pedal has been released. In all such cases, the following modification should be carried out.

PROCEDURE:REMOVAL OF BRAKE DRUMS:

- (a) Jack up front of car, support on suitable trestles, remove road wheels and brake drums.
- (b) Where steady bracket is fitted to grease catcher assembly, withdraw front hubs by removing split pin and nut on stub axle, and remove grease catcher assembly by undoing the eight retaining nuts and spring washers. (Fitted after Chassis No: B-445DZ, 477, 489, 493-DZ onwards).

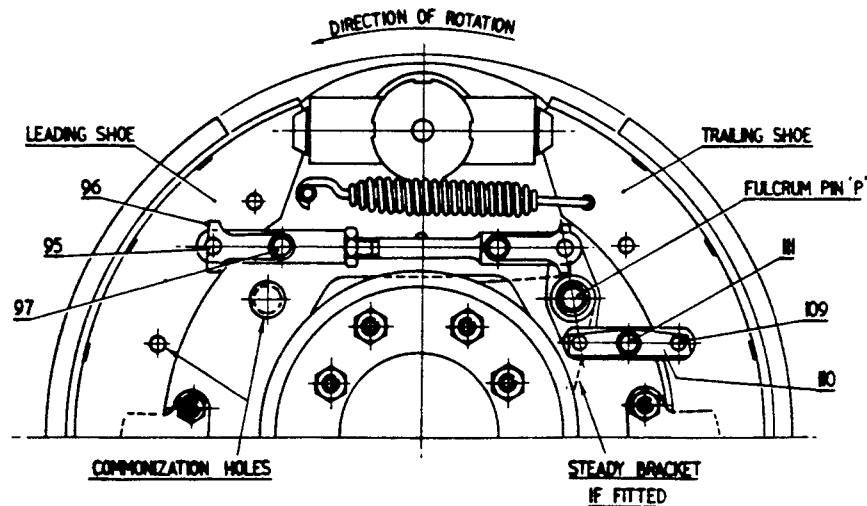

FIG. 1.

REMOVAL OF EQUAL WEAR LINKAGE (FIG.1).

- (a) Remove setscrew and spring washer (111) and the locking plate (110) and by easing the load from the pull-off spring, withdraw pin (109).
- (b) Remove setscrew and spring washer (97) and locking plate (96) and withdraw pin (95).
- (c) Remove equal wear linkage from fulcrum pin (P) complete.

**Bulletin**

MODEL BENTLEY MARK VI

- 2 -

- (d) Remove fulcrum pin (P) from brake carrier plate, by undoing retaining nut and spring washer on the back of the carrier plate.
- (e) Withdraw rubber plug from the carrier plate front commonization hole, and replace in the rear hole from which the fulcrum pin (P) was removed.
- (f) Replace the fulcrum pin in the front commonization hole.

REMOVAL OF BRAKE SHOES:

- (a) Remove both brake shoes.
- (b) With rasp or coarse file, carefully back off the leading 3 ins. of the leading shoe and the leading 4 ins. of the trailing shoe.
- (c) Replace both brake shoes.

REPLACEMENT OF EQUAL WEAR LINKAGE:

- (a) Replace the existing push rod and jaw of the equal wear assembly with the strengthened parts Nos. RG-6045/6 and nut K-4010/Z.  
NOTE: If these parts are not available, the existing push rod and jaw may be used, but should be replaced at the first opportunity.
- (b) Invert equal wear linkage assembly, and replace on fulcrum pin (P). (The short link should now be to the front of the car, and will line up with the lowest of the three top holes in the leading shoe, and the push rod will be to the rear and will line with the second hole from the top in the trailing shoe).
- (c) Replace pin (109) in the short link, locking plate (110) and the setscrew and spring washer (111).

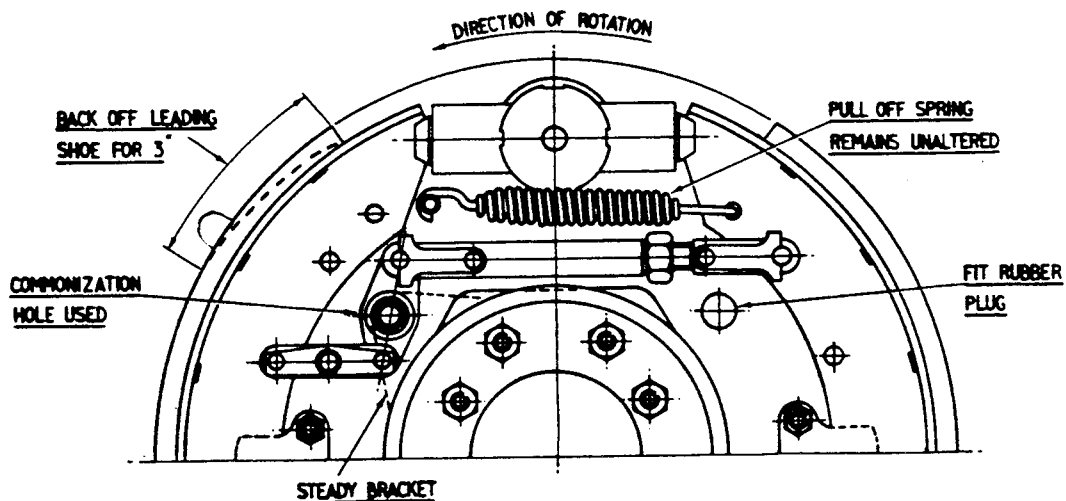

FIG. 2.

ALL COMMUNICATIONS SHOULD BE ADDRESSED TO  
BENTLEY MOTORS (1931) LTD., SERVICE STATION, HYTHE ROAD, WILLESDEN, LONDON, W.2

- 3 -

- (d) Replace pin (95) in the push rod, locking plate (96), and the setscrew and spring washer (97).
- (e) On cars fitted with the steady bracket, the grease catcher assembly from the left-hand wheel must be replaced on the right-hand wheel and vice-versa.
- (f) Replace the front hubs, and secure the retaining nut and washer.

CENTRALIZATION OF BRAKE SHOES:

- (a) From a piece of light gauge steel, make up a trammel as shown in (FIG. 3) to fit over two of the wheel studs on the hub, and bend the pointer to touch lightly on the face of the brake linings.

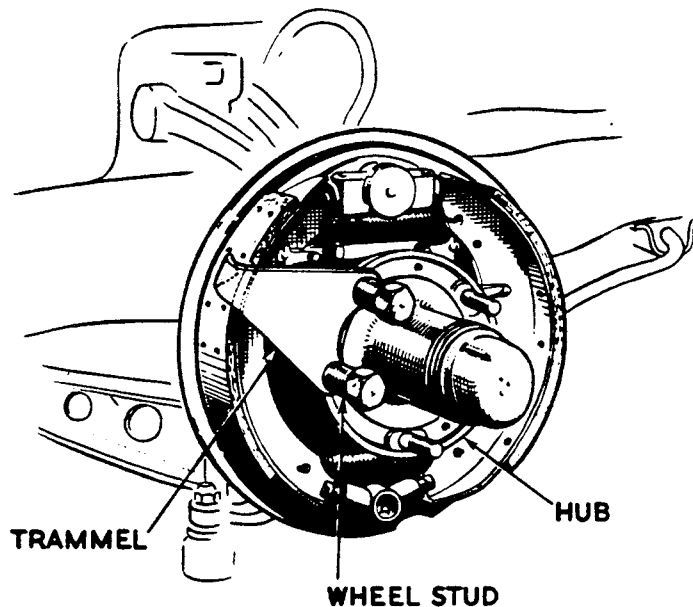

FIG. 3.

- (b) Temporarily replace the brake drum, and after operating front brakes from the master cylinder, externally adjust front brake shoes.
- (c) Remove brake drums and fit trammel on any two wheel studs.
- (d) By making suitable adjustments to the brake equalizer push rod, centralize the brake shoes, rotating the trammel about the shoes as a gauge.
- (e) When shoes are centralized, tighten the locknut on the push rod, and replace brake drums and road wheels.
- (f) Finally check external adjustment of brakes.

**Bulletin**

MODEL: BENTLEY MARK VI

- 4 -

MATERIALS REQUIRED.

<u>PART NO:</u>	<u>DESCRIPTION:</u>	<u>NO. OFF:</u>
RG-6045	Jaw Push Rod.	2 Off
RG-6046	Push Rod.	2 Off
K-4010/Z	Nut.	2 Off



MODEL BENTLEY MARK VI

FOR INFORMATION:PROTECTION TO THE SERVO AGAINST THE INGRESS OF WATER  
IN WET WEATHER.

Current Bentley chassis in production are provided with protection against the possible loss in servo efficiency in wet weather, due to water finding its way on to the friction surfaces.

This protection consists of an additional undershield, which is fitted over the existing triangular gap formed between the frame side member and the cruciform member forward of the battery container, together with a vertical baffle plate located just in front of the servo unit itself.

This modification is now offered as a chargeable improvement for fitting to existing models of earlier chassis, and its incorporation is recommended in all cases where servo inefficiency is traced to water on the friction faces.

The necessary instructions for fitting, together with the list of material required, will be found contained in this leaflet.

FITTING PROCEDURE.

FIG. 1. FITTING OF UNDERSHIELD.

1. Place the car over a pit, or elevate on a suitable hoist.
2. Remove the battery.
3. Remove the existing right-hand rear undershield immediately below the servo unit.
4. Offer up the new undershield from below the chassis and cover the triangular gap formed by the frame side member and cruciform member forward of the battery container. Mark off the relative positions for the two

bolt holes in the lower flange of the frame side member, also for the two supporting brackets as shown in Fig.1. Drill the two 0.250" dia. bolt holes in the frame side member.

5. Drill the blank flange of each bracket assembly to accommodate two 2-BA securing bolts respectively. Offer up the brackets in position on the cruciform and gusset respectively and mark off for the 2-BA securing bolt holes. Drill the two members accordingly and secure the brackets.

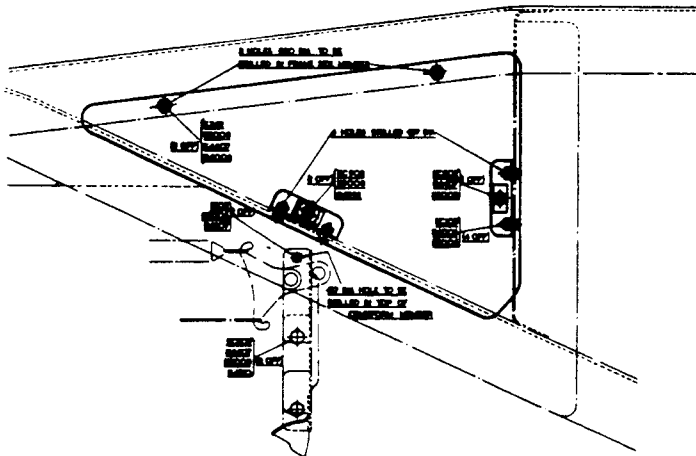
NOTE: Certain chassis will be found to have these brackets already fitted.

# Bulletin

MODEL BENTLEY MARK VI

- 2 -

6. Fit the new undershield.  
**NOTE:** The enlarged bolt hole in the new undershield is to allow for variations in chassis construction and should correspond with the bracket on the cruciform member. A special plain disc washer is supplied to prevent the head of the securing bolt passing through the plate when this is fitted.
7. Offer up the baffle plate with its flanges towards the engine, forward of the servo unit, and mate the head of the leading rivet securing the spring clip to the top of the cruciform with the radiused slot cut in the top flange of the plate. Mark off the relative position for the 2-BA bolt hole in the top of the cruciform as shown in Fig.1. Drill accordingly.
8. Fit the rubber protection piece to the baffle plate as shown in Fig.2.  
 Both the rubber and the retaining strip should be fitted on the ENGINE side of the plate, with the nuts for the securing screws on the obverse face.

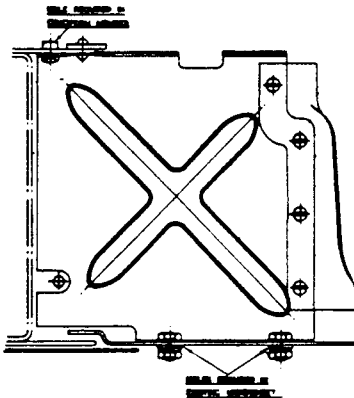

9. Fit the baffle plate to the cruciform, and then reposition the existing rear undershield temporarily below the servo unit. Mark off the undershield to correspond with the two 0.250" dia. bolt holes in the lower flange of the baffle plate. Remove the undershield and drill accordingly. Refit the undershield and bolt this to the lower flange of the baffle plate, using the two set bolts provided.

FIG. 2. BAFFLE PLATE.

MATERIAL REQUIRED.

RE.6977	Undershield.	1	Off
RE.6978	Baffle Plate.	1	"
RE.6979	Rubber Protection Piece-Baffle Plate.	1	"
RE.6999	Metal Retaining Strip-Protection Piece.	1	"
RF.3824 x	Undershield Support Brackets.	2	"
K. 1910	Setscrews-2 BA-Securing Protection Piece.	4	"
KC.902	Setscrews-0.250" - For Undershields.	4	"
K. 242	Bolts-Sqr.Hd.-Securing Undershield to Frame.	2	"
K. 102	Bolt-2 BA-Securing Baffle Plate to Cruciform.	1	"
KC.103 x	Bolt-2 BA-Securing Support Brackets.	4	"
K. 4307	Nuts-2 BA-For K.1910 & K.102.	5	"
K.4310	Nuts-Lock-0.250" dia.-For Baffle Plate to Undershield.	2	"
K. 4008	Nuts-Plain-0.250" dia.-Undershield to Frame.	2	"
K. 4006 x	Nuts-2 BA-Securing Support Brackets.	4	"
K. 9006	S.Washers-2 BA-For K.1910, K.102 and KC.103 (x)	9	"
K. 9008	S.Washers-0.250"-For Undershields.	6	"
R. 4292	Special Plain Washer-Cruciform Bracket to Undershield.	1	"
K. 4404	P.Washers-2 BA-For K.1910.	4	"
K. 4407	P.Washers-0.250"-For Undershields.	5	"

**NOTE:** Items above marked with an x to be ordered only when no brackets are fitted to chassis.



MODEL

BENTLEY MARK VI

- 3 -

Further to the above, it is recommended that additional protection plates for the throttle control countershaft on the right-hand side frame member are also fitted whenever this modification is incorporated on early type chassis.

Due, however, to the fact that in a number of cases these plates have already been fitted in service, it is considered advisable for a preliminary check to be made before ordering the necessary material.

As a means of guidance, the exact locations for these plates are as follows:-

- (a) Hand-hole in the side of the right-hand frame member just forward of the front body support bracket.
- (b) Gap below the chassis frame formed by the frame side member, engine bearer and cruciform member.

In the event of these plates being necessary, they should be fitted in accordance with the instructions given below:-

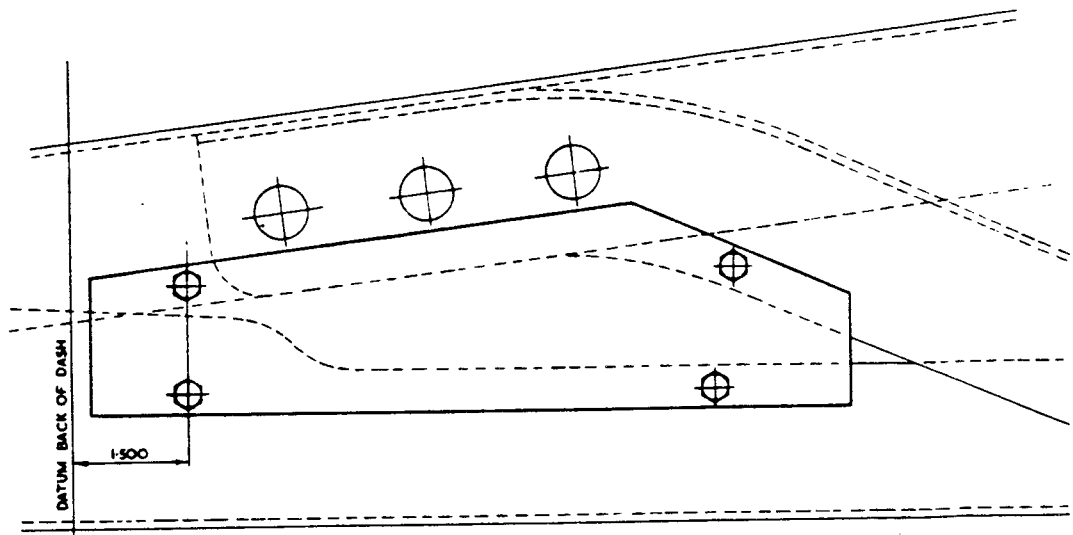

FIG. 1 FITTING OF UNDER-FRAME COVER PLATE.

1. Fit the under-frame cover plate (RF-6209) as shown in Fig. 1.
  - a) Offer up the plate, and mark off the relative positions for the four retaining setscrews.
  - b) Drill the four holes 0.1562" dia., and then tap 2 BA (31 T.P.I. R/H).
  - c) Fit the cover plate.

ALL COMMUNICATIONS SHOULD BE ADDRESSED TO  
BENTLEY MOTORS (1931) LTD. SERVICE STATION, HYTHE ROAD, WILLESDEN, LONDON, N.W.2



2. Fit the hand-hole cover plate (RF-6213) as shown in Fig. 2.

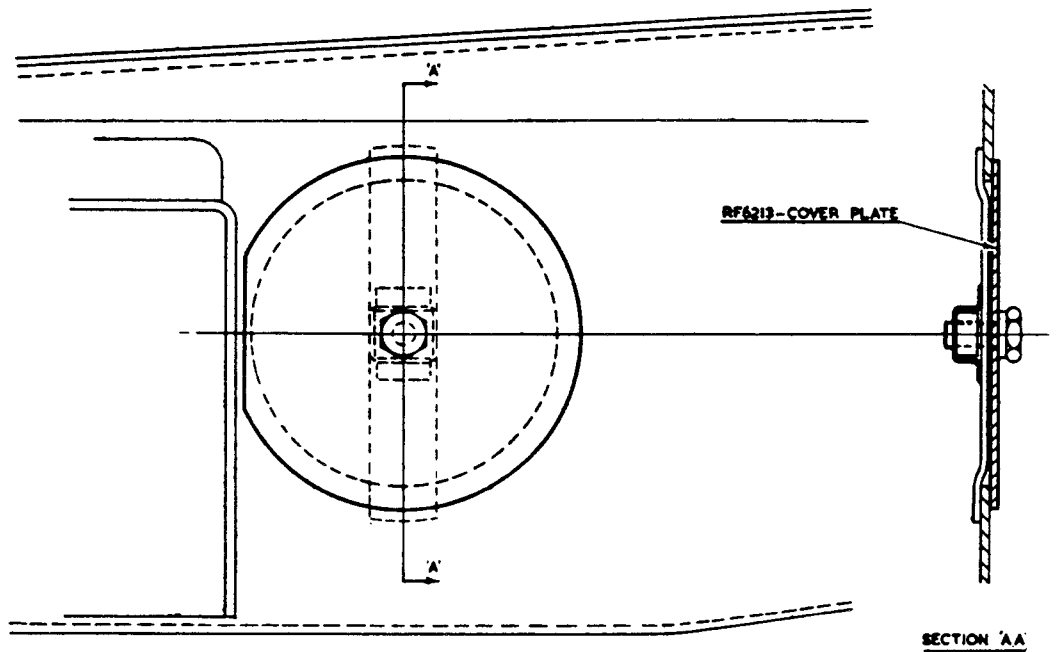

FIG. 2. METHOD OF FIXING COVER PLATE OVER HAND-HOLE.

MATERIAL REQUIRED.

RF-6209	UNDERFRAME COVER PLATE.	1 off.
RF-6213	HAND HOLE COVER PLATE.	1 off.
RF-6210	RETAINING PLATE ASSY. FOR HAND HOLE COVER PLATE.	1 off.
KC-151	SETSCREW - UNDERFRAME COVER PLATE.	4 off.
K-9006	WASHER - SPRING - FOR ABOVE.	4 off.
KC-278	SETSCREW - RETAINING PLATE ASSY.	1 off.
K-9009	WASHER - SPRING - FOR ABOVE.	1 off.

FOR INFORMATION:FRONT BRAKES - RIGHT-HAND & LEFT-HAND DRIVE("REVISED STEERING GEOMETRY".)1. DESCRIPTION:

Commencing G Series, i.e. Chassis No.B-1-GT, and onwards, new front brakes are fitted which differ from the front brakes fitted to chassis prior to 'G' series, chiefly in the use of an internal hydraulic cylinder, which acts directly on the shoes in place of an external cylinder(expander) operating the shoes through a wedge mechanism.

The brake cylinder follows standard practice, and contains the usual two rubber cups and pistons, with expander spring between. The pistons act on the shoe tips through short push rods, which pass through rubber dust excluders in the ends of the cylinder. Unlike the previous brake, the cylinder body is rigidly attached to the carrier plate by three studs. The holes for the studs in the carrier plate are elongated so that the cylinder can be centralised during initial assembly, but after this operation has been carried out, the cylinder is securely locked to the carrier plate by fully tightening the studs. Although the cylinder body is fixed, the loads on the two shoe tips are nevertheless balanced by virtue of the column of oil between the two pistons.

The equal wear linkage between the two shoes also differs from the previous arrangement. The shorter of the two links is now eliminated, one arm of the balance lever being attached directly to the web of the trailing shoe, while a long link connects the other arm to the web of the leading shoe. (See Fig.1). The balance lever, instead of having a fulcrum consisting of a pin attached to the carrier plate, is pivoted on the end of a short push rod which butts against the cylinder body. The pull-off spring is also attached to the cylinder body, so that the whole assembly of shoes and inter-shoe linkage is mounted off the cylinder, and will slide bodily if the three studs attaching the cylinder to the carrier plate are loosened. The bedding of the two shoes can thus be equalised without any adjustment of the inter-shoe linkage being necessary, as was the case on the previous brake. The long link of the inter-shoe linkage is still adjustable, but this merely provides for an initial "sizing" operation to set the brake to the correct diameter over the linings to suit the drum. (See setting instructions.) The shoes have rather narrower webs than formerly, to provide a certain degree of flexibility. The same adjuster unit is used exactly as before.

2. SETTING INSTRUCTIONS:

When, during service, the front brake shoes have to be removed for replacement by a set of reconditioned shoes (new linings), or should it be found necessary to centralise the shoes in relation to the drum, the following are the setting instructions:-

- 2 -

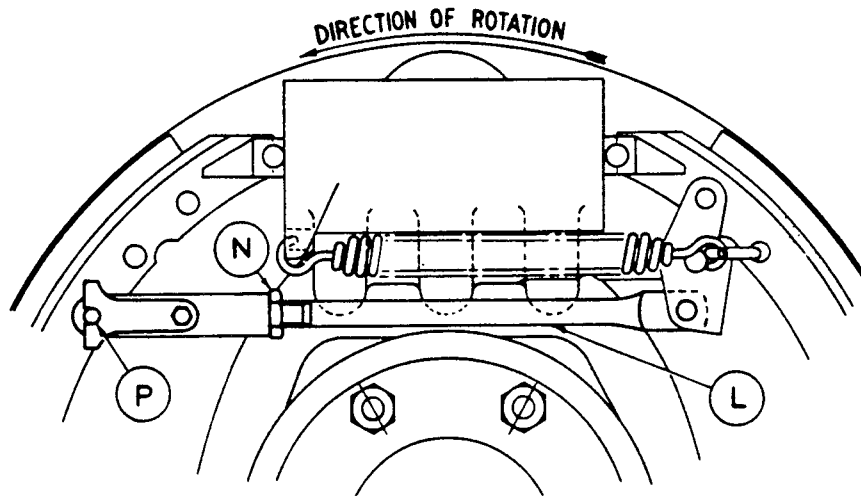

FIG. 1. DIAGRAM - SETTING INSTRUCTIONS - FRONT BRAKES.

- (i) Build up the brake complete, but do not fit the locking plate for pin P, Fig. 1, or lock the nut N. For an initial setting, the link L, should be adjusted to 7.375" (187.3 m/m) between the pin centres.
- (ii) Screw back the hand adjuster as far as it will go, and slacken off the two setscrews securing the adjuster unit to the carrier plate.
- (iii) Slacken off the three nuts securing the hydraulic cylinder unit to the carrier plate, so that it is free to float.
- (iv) Fit the brake drum to the hub. If the drum cannot be fitted over the shoes, lengthen the link L, until it can. This is most easily done by first detaching the pull-off spring, when the pin P can easily be withdrawn.
- (v) With the drum in position, check the total number of "CLICKS" obtainable on the adjuster in bringing the shoes into contact with the drum, which should be between 9 and 15.
- (vi) If more than 15 "CLICKS" are obtained, remove the drum, shorten the link L, and try again. If less than 9 "CLICKS" are obtained, lengthen the link L, and try again. One complete turn of the jaw on link L, corresponds to about 3 "CLICKS" of the adjuster.
- (vii) When the correct length of link L, is obtained, and with the drum still in position, centralise the assembly by screwing up the adjuster until the shoes are hard against the drum and then fully tighten the three nuts securing the hydraulic cylinder unit to the carrier plate, and the two setscrew securing the adjuster unit to the carrier plate.

**Bulletin**

MODEL BENTLEY MARK VI

- 3 -

- (viii) Slacken back the adjuster and remove the drum, fit the locking plate for pin P, and lock the nut N. Check that all other split pins etc. are correctly fitted, replace the drum.

### 3. EXTERNAL ADJUSTMENT:

When replacement shoes with new linings have been fitted during service and correctly adjusted, it should be noted that in order to allow for "growth" of the new linings due to temperature effects the external adjustment must always be set back six or seven "CLICKS" for the initial road test. Proceed as follows:-

- (a) Rotate the adjusters in a clockwise direction until obvious resistance is felt. The resistance should be equal for the two brakes, and should the last "CLICK" on either adjuster require noticeably greater force to obtain, this adjuster should be turned back to the previous "CLICK". From this position, turn back the two adjusters from six to seven clicks.
- (b) After the road test (bedding-in of linings), and before delivery to an Owner, again rotate the adjusters in a clockwise direction as described above and finally turn back each adjuster three "CLICKS".
- (c) The Owners Handbook will still say two "CLICKS" as being the correct adjustment, but it is anticipated that the linings will have become stabilised before the Owner need have occasion to re-adjust the brakes.

- (1) CATEGORY 2 ACTION: (Australia, S. Africa & S. America ONLY).
- (2) FOR INFORMATION: (Home and Remainder of Overseas Retailers).

REAR BRAKE EQUALISER SUPPORT

Instances have occurred where the rubber support (RG-3552) for the rear brake equaliser bar has fractured on existing Bentley Mark VI cars in service.

In order to obviate this a modified type of support assembly has now been introduced for incorporation under the following conditions:-

- (a) Australia, S. Africa & S. America ONLY: - Modified support assembly to be incorporated when car comes in for service, irrespective of the condition of the existing rubber support.
- (b) Home & Remainder of Overseas Retailers: - Modified support assembly to be fitted ONLY when the existing rubber support requires replacing in service.

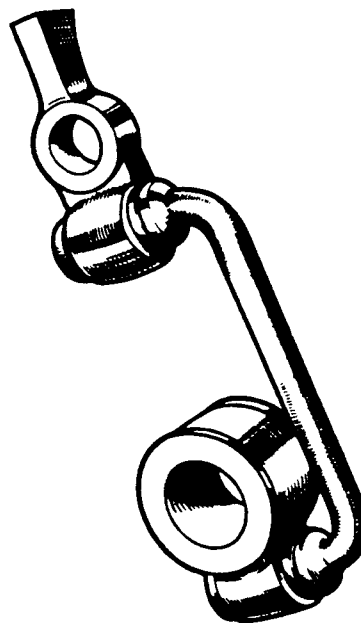

FIG. 1. MODIFIED TYPE SUPPORT

The modified type support assembly, illustrated in Fig.1 above, consists of a "U" shaped metal link, which is retained at either end by brackets in silentbloc bushes. The upper bracket has a radiused face to correspond with the outside of the rear axle tube, while the lower bracket carries another silentbloc bush through which the equaliser bar passes.



- 2 -

FITTING PROCEDURE

- (1) Disconnect the existing rubber support from the rear axle tube at the top, and then remove the equaliser bar from the car. (N.B. In certain cases small brass distance pieces will be found fitted on the forward retaining pin at the front end of the bar. These should be refitted in identical manner when re-assembling the bar).
- (2) Remove the existing rubber support from the equaliser bar, and then clean off all mud and dirt from the bar to facilitate the fitting of the new assembly.

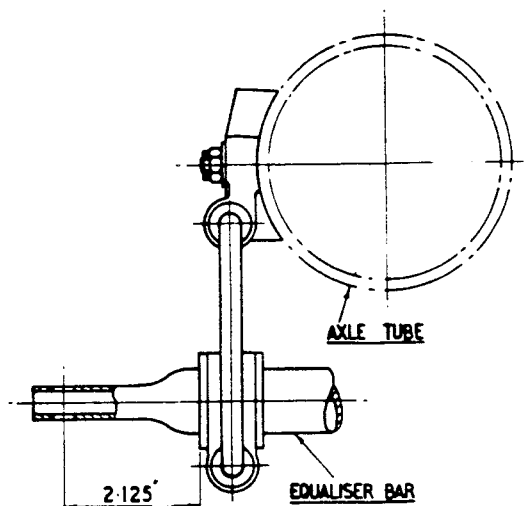

FIG. 2. FINAL POSITION FOR  
MODIFIED SUPPORT.

- (3) Thread on the new support assembly from the front end of the equaliser bar, and slide the assembly along the bar until the outer face of the silentbloc bush is exactly 2.125" distant from the centre of the bolt hole at the rear of the bar (See Fig. 2. above). Due to the interference between the rubber bush and the bar, it is recommended that some form of lubricant, e.g. French chalk or soap, is used to facilitate sliding the assembly along the bar.
  - (4) Fit the upper bracket to the existing stud on the axle tube, replace the existing plain washer (distance piece), and then secure by means of the thinner castellated nut provided, locking this by fitting a new 1/16" split pin. Reconnect the equaliser bar.
- NOTE:- Constructional variations in the rear axle tube may result in

**Bulletin**

MODEL BENTLEY MARK VI

- 3 -

a "forging flash" preventing the radiused face of the upper support bracket seating correctly when finally assembled. In such cases the "forging flash" should be removed from that part on which the bracket seats to ensure a true bedding between the two mating faces. Under NO circumstances must any metal be removed from the radiused face of the upper bracket as this has been filed to a gauge prior to delivery.

MATERIAL REQUIRED

<u>PART NO.</u>	<u>DESCRIPTION.</u>	<u>NO. REQD.</u>
RG.5460	Assy. Rear Brake Equaliser Support.	1 off.
KB.3637	Castellated Retaining Nut - Support (Axle tube)	1 off.
K.4602	Split Pin 1/16" x 3/4" long.	1 off.

ALL COMMUNICATIONS SHOULD BE ADDRESSED TO:

BENTLEY MOTORS (UK) LTD. SERVICE SECTION, 111, NEWBURY ROAD, READING, RG2 9AT

SB/GF. 28.6.50.

SECTION J.



MODEL BENTLEY MARK VI

CATEGORY 2 ACTION:ADDITIONAL PROTECTION FOR THE SERVO AND SIDE CHANGE GEAR MECHANISM.(STANDARD STEEL SALOONS ONLY)

Investigations have shown that the deletion of the dashboard side mounting brackets (Service Bulletin BB-115) renders it possible in wet weather for water to reach the servo motor and gear change mechanism through the gap between the front of the body and frame member.

To obviate this, additional protection for these components has been provided on current chassis in production from B-229-LH onwards, and Retailers are requested to take the necessary retrospective action to ensure that this is also incorporated on earlier model Standard Saloons in their areas on which these brackets have been deleted. (N.B. The deletion of the dashboard side mounting brackets on Standard Steel Saloons was first effected in production at Chassis No. B-153-JN. The chassis numbers involved are therefore from B-153-JN to B-227-LH inclusive, plus all other cars on which these side mounting brackets have been removed in service).

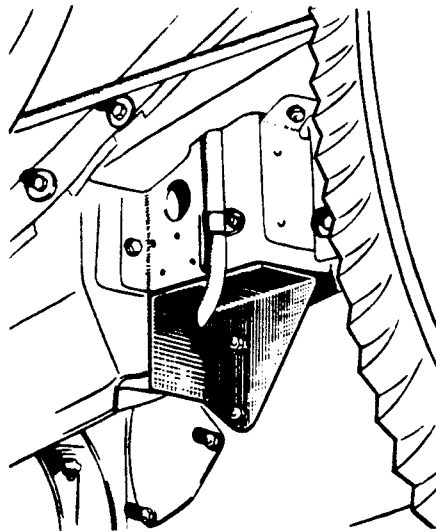

This protection consists of a flanged plate (Part No. RF-8881) which is fitted in the position originally occupied by the lower dash mounting bracket on the right-hand side of the chassis as shown in the above illustration. The existing bracket mounting holes in the frame are used for fixing the plate, and it should be noted that when this is finally fitted, there must be a clearance of approximately 0.187" between the top and rear flanges and the dash and body respectively. The two bolt holes drilled in the plate itself are of a slightly larger diameter than the retaining bolts supplied thus permitting a certain degree of adjustment when fitting the plate.

MATERIAL REQUIRED

RF-8881	Protection Plate.	1	Off	K-4310/Z	Nut	2	Off.
KO-204/Z	Retaining Bolts for above-0.250" dia.	2	"				
K-9008/Z	Spring Washer	2	"				
K-4407/Z	Plain Washer	2	"				

ALL COMMUNICATIONS SHOULD BE ADDRESSED TO

BENTLEY MOTORS (1931) LTD. SERVICE STATION, HYTHE ROAD, WILLESDEN, LONDON, N.W.10

SE/GF. 7/SP. 15.8.51.

SECTION



MODEL BENTLEY MARK VI

Cancels BB-186 dated 15.4.54.

FOR INFORMATION:SEALING THE BRAKE SERVO MOTOR.

In order to prevent the possibility of oil seepage into the servo motor, the joint between the flange of the spring backing plate and the pressure plate is being coated with "Wellseal" on current production. "Wellseal" is a sealing compound with a rubber solution base which remains soft and pliable when dry.

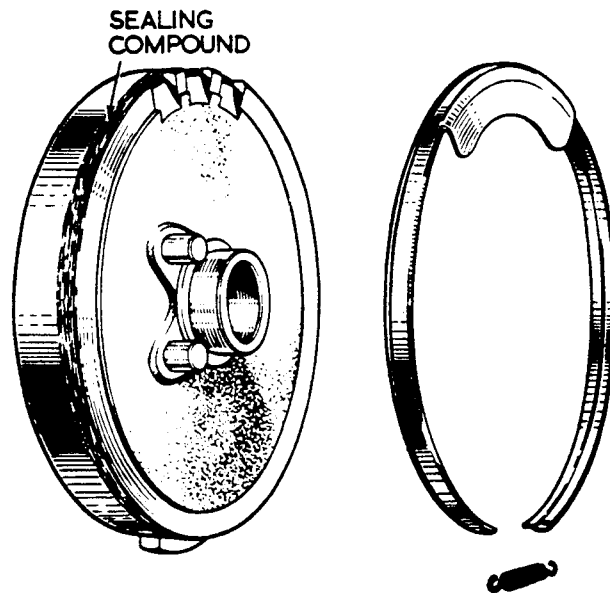

Retailers are advised that, whenever a servo motor is removed for overhaul or other reason, it should be treated with "Wellseal" or an equivalent compound. After assembling the servo in the usual way, but before fitting the protector ring, the compound should be applied with a thin brush as shown in the illustration.

No further sealing is necessary. The drain holes at the bottom of the spring plate flange and the ventilation slots at the top of the pressure plate, which are covered by the water excluder attached to the protector ring, must be kept clear.

Tins of "Wellseal" are available from the London Service Station, or direct from Messrs Wellworthy Ltd, Radial Works, Lympington, Hampshire., for use in the United Kingdom.

For overseas use the Minnesota Mining and Manufacturing Coy's EC.802 Sealer is recommended. This can be thinned down by the addition of Methyl Ethyl Ketone in order to facilitate application. The thinner is available from most manufacturing chemists. A list of oversea Distributors from whom EC.802 Sealer may be obtained is attached.



MODEL BENTLEY MARK V.

<u>Country.</u>	<u>Distributor.</u>
LEEWARD ISLANDS.	L.J.Williams Marketing Co.Ltd., 41, Orange Street, Kingston, Jamaica, B.W.I.
ARGENTINA.	"Eberson" Soc.Resp.Ltda., Belgrano 1670, Buenos Aires.
ARUBA.	Moises de Marchena & Sons, Wilhelmenastraat 11, Oranjestad, Aruba, N.W.I.
AUSTRIA.	Otto Winds, Melkengasse 6, Vienna, 6.
BAHAMAS.	L.J.Williams Marketing Co.Ltd., 68, Marine Square, Port of Spain, Trinidad.
BARBADOS.	Gordon, Grant & Co.Ltd., 404, Plantations Bldg., Broad Street, (P.O.B.280).,Bridgetown.
BELGIUM CONGO.	Drinkwater Automotive Eng. Works Ltd., Dawson St., UMTALI, S.Rhodesia.
BELGIUM.	Willy Sturm, 42, rue Locquienghien, Brussels.
BERMUDA.	Ambard & Company, Reid Street, Hamilton.
BOLIVIA.	Garcia, Mendieta y Cia, S.A., Casilla Correo No.958, La Paz.
BRITISH GUIANA.	L.J.Williams Marketing Co.Ltd., Robb & High Street, Georgetown, Demara.
BURMA.	Gillanders Arbuthnot & Co., P.O. Box 845, Rangoon.
CEYLON.	Muller & Phipps (Asia) Ltd., Negris Bldg., York Street, Colombo.
CHILE.	Perez, Reitze y Benitex, Casilla 2482, Calle Santa, Rosa 15, Santiago.
COLUMBIA. (Except for Western States).	Ivar Hilstad & Cia. Ltd., Apartado Aereo 119, Barranquilla.

ALL COMMUNICATIONS SHOULD BE REFERRED TO  
BENTLEY MOTORS (INDIA) LTD.



MODEL BENTLEY MARK VI

<u>Country.</u>	<u>Distributor.</u>
COLUMBIA. (Western States)	Rojas Hermanos Ltda., Apartado Aereo 1313, Cali.
COSTA RICA.	Enrique Herrero & Cia. Ltda., Apartado 677, San Jose.
CUBA.	Casa Rex-tone, Neptuno 1060, Havana.
CURACAO.	Moises de Marchena & Sons, P.O. Box 72, Willemstad.
DENMARK.	J.A.Wallin, Sct. Kjudsvej 22, Copenhagen.
WINDWARD ISLANDS.	L.J.Williams Marketing Co., Jamaica.
DOMINICAN REPUBLIC.	Dominican Motors Co., La Cotolica-E. Tejera, Ciudad Trujillo.
ECUADOR.	Luis Vallejo Araujo, Chemborazo 406, P.O.B. 717, Guayaquil.
FINLAND.	Oy Gronblom Ab. S.Esplanadgatan 14, Helsinki.
FRENCH MOROCCO.	Societe Africaine d'Achats et de Representations Industrielles, 22, Rue de lay Haye, Casablanca.
GREECE.	J.P.Combis, Athinas Street, 17-D, Athens.
GUATEMALA.	Escarra Ymbert & Cia. Ltda., Apartado 302, Guatemala City.
HAITI.	Haytian American Industrial, Development Co. S.A., Port-au-Prince.
HOLLAND.	Pieterse & Wildenberg, Maasdamstraat, 2, Rotterdam.
HONDURAS.	Quinchon Leon & Cia., Teguciagalpa, D.C.
ICELAND.	G.Thorsteinsson & Johnson, P.O. Box 881, Grjotagotu, Reykjavik.



MODEL BENTLEY MARK VI

<u>Country.</u>	<u>Distributor.</u>
INDIA.	Gillanders Arbuthnot & Co., 3, North Beach Road, P.O.B. 261, Madras.
INDO - CHINA.	East Asiatic Co.Ltd., Saigon, Viet-Nam.
INDONESIA.	Kian Gwan Co., Asemka 18, Kjakarta.
IRELAND.	Rutledge & Thompson Ltd., 3, Corn Exhcange Place, Dublin, C.5.
ISRAEL.	Israel General Automotive Supply, 25, Hakinshon St., P.O.Box 5184, Tel Aviv.
ITALY.	Vagnone & Boeri, 9-11, Via Bogino Torino.
BRITISH WEST INDIES.	L.J.Williams Marketing Co.Ltd., Jamaica.
JAPAN.	International Aviation Asscts., 34, Uguisidani-cho, Shibuya-ku, Tokyo.
KENYA COLONY.	Gilfillan & Co.Ltd., P.O.Box 644, Nairobi.
KOREA.	American Trading Co. Inc., 96, Wall Street, New York City, N.Y.
LEBANON.	Michel Andraos, P.O. Box 447, Beirut.
MOZAMBIQUE.	Gandra & Lagoa, Ltda., Rue Duque de Terceira 315, Porto, Portugal.
NEW ZEALAND.	John Chambers & Sons Ltd., 41, Fort Street, Auckland, C.I.
NICARAGUA.	Eric Clerk & Cia. Ltda., P.O.B. 446, Managua.
NORWAY.	C.Frimann-Dahl A/S, Dronningensgt, 10-12, Oslo.

ALL COMMUNICATIONS SHOULD BE ADDRESSED TO:  
BENTLEY MOTORS (UK) LTD. SERVICE STATION, 11 THE LODGE

SECTION



MODEL BENTLEY MARK VI

<u>Country.</u>	<u>Distributor.</u>
NYASALAND & RHODESIA.	Drinkwaters Auto. Eng. Wks., Dawson Street, UMTALI, S.Rhodesia.
PAKISTAN.	Muller & Phipps (Pak.) Ltd., 172, Napier Road, Karachi.
PANAMA.	Empresas Panamenas S.A., P.O.B. 3348, Estafeta, No.1.
PERU.	Dupont Peru, S.A., Edificio Tecna. Avenida Tacna, 592, Apartado 2787, Lima.
PERSIAN GULF.	A.A.Zayani & Sons, P.O. Box 32, Bahrein.
PHILIPPINES.	Muller & Phipps (Manila) Ltd., Bonifacio Drive, Port Area, P.O. Box 950, Manila.
PORTUGAL.	Gandra & Lagoa, Ltda., Rue Duque da Terceira 315, Porto.
EL SALVADOR.	Thoresen & Co. P.O.B. 267, San Salvador.
SINGAPORE.	Kian Gwan (U.K.) Ltd., United Dominions Hse., 53, Eastcheap, London, E.C.3.
SOMALILAND.	Gilfillan & Co., P.O.B. 644., Nairobi, Kenya Colony.
SOUTH AFRICA.	Wlt. McNaughtan & Co. (Pty) Ltd., P.O.B. 8666, Johannesburg.
SWEIDEN.	Landelius & Bjorklund, 6A, Bryggargatan, Stockholm.
SWITZERLAND.	Wahl & Lehmann, Sihlquai 55, Zurich 5.
SYRIA.	Automotive & Industrial Eqp., Co. P.O.Box 89, Damascus.
TANGANYIKA.	Gilfillan & Co., P.O.B. 644, Nairobi, Kenya Colony.
THAILAND.	Kian Gwan Co., (Thailand) Ltd., " " Building, 203, Suriwongse Rd., Bangkok.





MODEL BENTLEY MARK VI

<u>Country.</u>	<u>Distributor.</u>
UGANDA.	Gilfillan & Co., Ltd., P.O.B. 644, Nairobi, Kenya Colony.
URUGUAY.	Varela Radio & Cia., Cerro Negro 999, Casilla Correo, 417, Montevideo.
+VENEZUELA.	Importadora Cientifica S.A., P.O. Box 2083, Caracas.
YUGOSLAVIA	Otto Winds, Nelkengasse 6, Vienna V1, Austria.

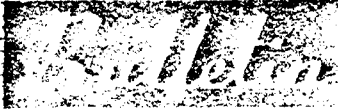

MODEL BENTLEY MARK V

FOR INFORMATION.REGRINDING BRAKE DRUMS.

Retailers are advised that brake drums may be reground to remove scoring or to restore a true diameter in accordance with the data given below. Regrinding should not normally be required unless ovality exceeds .010" - .015" (.25 to .38 m/m).

Standard Internal Diameter of Drum      12.250" (31.115 c/m)  
(All chassis series - Front and Rear)

Grinding Limit      .050" (1.27 m/m)

A stone  $3\frac{1}{2}$ " x  $1\frac{1}{4}$ " x  $\frac{1}{2}$ " of grade 60 N.V. is recommended. Only the minimum amount of metal necessary to achieve a smooth, clean surface should be removed. Oversize brake shoe linings are not required.

### FRONT BRAKE HOSES.

In the interests of safety, it has been decided to specify definite mileages at which front brake hoses should be re-newed. This Bulletin gives details of the types of hoses that have been fitted and of the replacement action necessary.

#### Types of Front Brake Hose.

Four different types of hose have been fitted on production Chassis Numbers at which the changes took place are not recorded but approximate dates are given for guidance. The hoses are, however, readily distinguishable and are listed below in chronological order of fitting.

1. A smooth skinned hose of 9/16" (14.3 m/m) diameter. Fitted from commencement of production until August 1948.
2. A smooth skinned hose of .430" (10.9 m/m) diameter, having greater flexibility. Fitted from August 1948 to February 1950.
3. A hose with a chevron patterned skin of .430" (10.9 m/m) diameter, having larger end connections. Later editions of this hose carried a green plastic band indicating that it had been subjected to increased pressure tests. Fitted from February 1950 to November 1953.
4. A chevron patterned hose, as in 3, carrying a yellow plastic band, indicating a change from two to three ply and an increased barrelling of the end connections. Later editions of this hose have the figures L2 stamped on the hexagon indicating that the hose conforms with an agreed SAE specification. Fitted from November 1953 to date.

#### Action and Charges.

1. Hoses of types 1, 2, and 3 should be replaced by hoses of type 4 after 20,000 miles (32,000 kilometres).

Retailers are asked to carry out replacements in accordance with the mileage travelled, as cars come in for service. If the car is still within the guarantee period, charges may be submitted to the company in the usual way. A time of 2½ hours will be allowed for changing two hoses, bleeding the brakes and road testing.

If out of guarantee, material and labour are chargeable to the owner.

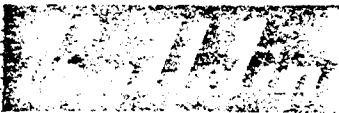

MODEL BENTLEY MARK VI

- 2 -

2. Hoses of type 4 should be re-newed after 40,000 miles. This mileage corresponds approximately to the mileage at which brakes are normally re-lined and charges should, therefore, be included with the re-line charge.

Parts Required.

RG.8484 Hose, Bracket to Brake Cylinder 2 Off.

It is appreciated that the life of a hose cannot be accurately predicted in varying conditions of service but it is felt that Owners will welcome the assurance that a replacement scheme of this nature will provide. Retailers co-operation in implimenting it is strongly requested.

Cancels BB-210 dated 11.2.55 and 29.8.56.

FOR INFORMATION.

SERVO JUDDER AND INEFFICIENCY.

A corrugated washer, Part No. R.5037, has been developed to overcome cases of servo judder on brake application. The washer is fitted between the brake actuating levers in place of the plain washer GB.5083 and effectively damps the servo output to prevent minor fluctuations in the brake linkage from developing into judder.

Retailers should fit the washer in all complaints of servo judder but, at the same time, check that obvious causes, such as air in the hydraulic system, maladjustment of the brake linkages and deterioration of the servo motor linings, are not responsible for the condition.

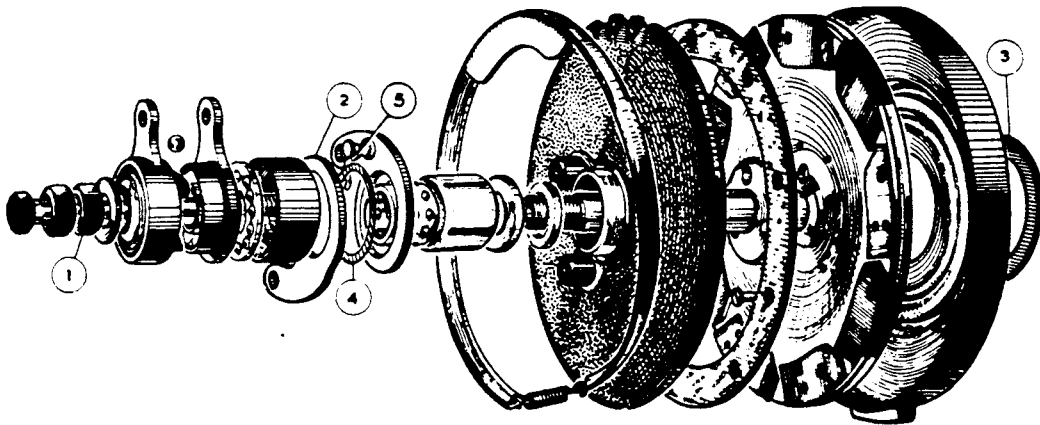

FIG.1. EXPLODED VIEW OF SERVO MOTOR.

1. Adjusting Nut.
2. Brake Actuating Levers.
3. Ferodo Washer (To be replaced by R.5285 if necessary).
4. Plain Washer GB.5083 (To be replaced by R.5037).
5. Spring Clip (To be removed).

On all early series cars the corrugated washer can be fitted without further modification, except from approximately B-152-UM onwards when the loading of the servo motor spring back plate was increased from 25 to 40 lbs. With the heavier load spring plate a thinner servo drive sealing washer R.5285 must be fitted in place of the Ferodo washer between the spring plate and the gearbox. This ensures that the combined end thrust of the spring plate and corrugated washer is not sufficient to prevent the brake actuating levers from returning to their off-stop on releasing the brake pedal.

# Bulletin

MODEL BENTLEY MARK VI

- 2 -

1. From approximately B-311-YA and onwards a spring clip was fitted to the upper brake actuating lever to eliminate servo "clonks", this will have to be removed if it fouls the corrugated washer when compressed.
2. Under certain circumstances it has been found that owing to servo manufacturing limits, difficulties have arisen in fitting the corrugated washer, and in order to overcome this, and to ensure a long service life, the following method of fitting is to be employed.

The complete servo motor is to be removed, dismantled, and a packing washer approximately .0625" thick placed between the pressure plate

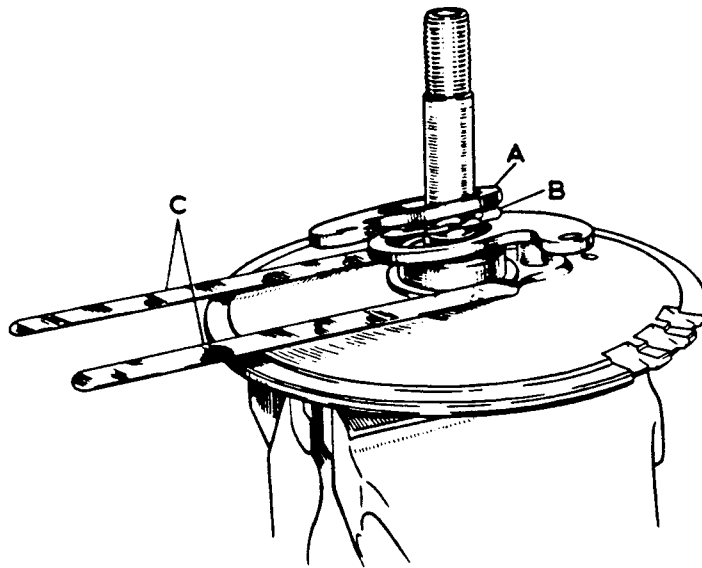

FIG.2.  
A. Brake Actuating Lever. B. Servo Washer (R.5037).  
C. Feeler Gauges.

and the flange on the servo shaft. The servo is then placed in a vice as shown (Fig.2), the corrugated washer fitted into position, and the servo assembled. The adjusting nut is tightened fully home, thus compressing the corrugated washer.

A spring balance is then attached to the brake actuating lever and the poundage figure accurately taken; this must be between 12 and 20 lbs (Fig.3).

If the figure is too high, the adjusting nut must be slackened, two feeler gauges (approximately 0.002" for every 5 lbs in excess poundage) placed between the lower brake actuating lever and the servo pressure plate and the adjusting nut tightened fully once more. This will compress the corrugated washer still further, so that when the feeler gauges are removed

- 3 -

and the adjusting nut re-tightened, a lower poundage figure will be recorded. This must be done, by increasing the feeler gauge thickness, until the brake actuating lever poundage is satisfactory.

Finally, remove the .0625" washer and re-assemble servo motor.

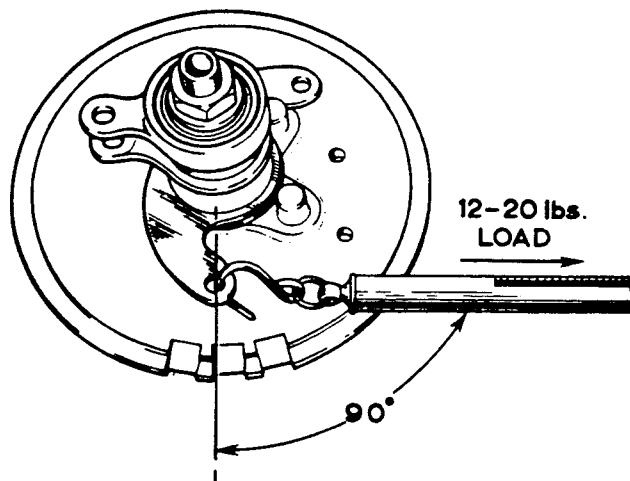

FIG.3.

3. Adjust the servo in the normal way as follows :-

- (a) Apply the handbrake so that the servo can be rocked backwards and forwards.
- (b) Tighten the adjusting nut until friction can just be felt between the pressure plate and the lined plate when rocking the servo. Slacken back the adjusting nut  $\frac{1}{3}$  of a turn, this should give approximately .018" (.45 m/m) clearance between the pressure plate and the lined plate. Press the pedal once to ensure that the outer cam lever has followed back with the nut. Lock the adjusting nut by tightening the outer nut.

4. Check that the pedal travel required to open the cam levers is between  $\frac{3}{8}$ " and  $\frac{5}{8}$ ".

**Bulletin**

MODEL BENTLEY MARK VI

- 4 -

5. Jack up the rear of the car and start the engine. Run in top gear at about 20 m.p.h. and apply the brakes. Check that on release the brake actuating levers return to their off-stops, allowing the balance lever assembly to return and the master cylinder to recuperate.

If the thrust applied by the spring plate and the corrugated washer is too great, friction may prevent the two brake actuating levers from returning when the brakes are released. This will only occur if the servo is incorrectly adjusted or if the more heavily loaded spring plate is also fitted with the original Ferodo washer. A buckled or distorted spring plate must be renewed.

PARTS REQUIRED.

R.5037	Corrugated Washer - Servo	1 off.
R.5285	Sealing Washer - Servo Drive	1 off.(If required)

SERVO INEFFICIENCY.

Whenever a servo is overhauled following a complaint of inefficiency which is found due to oil or water contamination of the liner and when there is no obvious source of leakage such as from the servo main shaft seal, the engine or chassis lubrication systems, or water leakage from the cooling system, the servo is to be completely sealed with the special rubber seal RH.377.

To do this the water drain on the servo spring back plate must be removed; this is simply done on 'R' type motor cars by unsweating, and on earlier series cars by removing the three .062" securing rivets.

The holes in the rim of the spring plate are then to be filled with solder which is best done by tinning the inside of the rim, resting the spring plate holes downwards on a sheet of asbestos, so that the solder is prevented from running through and building up on the outside of the rim.

The solder is then smoothed over and the spring plate re-painted with high quality air drying chassis black.

FITTING INSTRUCTIONS.

The servo spring plate, lined plate, pressure plate and servo main shaft are to be put together so that after the seal has been fitted the servo can be completely re-assembled and re-fitted, (Fig.4).

With the pressure plate uppermost, the rubber seal is placed on top with the flap covering the ventilating slots. The rubber seal is then placed right over the rim edge at the ventilating slots and without stretching, held there, then the opposite side is to be eased right over





MODEL BENTLEY MARK VI

- 5 -

the edge of the plate, not by pulling on the outer edge of the seal as might be expected, but by pulling on the inner diameter; this prevents distortion of the outer periphery. The rest of the seal is then eased into position, still pulling on the inside diameter until the inner periphery fits closely into the spigot running around the upper face of the pressure plate. The whole seal is then to be eased into position finally and retained by the protector ring which must be fitted with the lower rate spring RH.135, otherwise it will not fit over both the seal and the pressure plate. The spring is to be positioned towards the rear of the car and not to the lowermost position as was usual. On certain servos the ends of the brake actuating lever operating pins will be open; these must be sealed with two corks (Fig.4).

The servo can then be re-fitted to the car, the seal being finally checked after road test.

NOTE: It is not possible to use the rubber seal more than once, nor is it possible to use the seal if it has been stretched in an unsuccessful attempt to fit it.

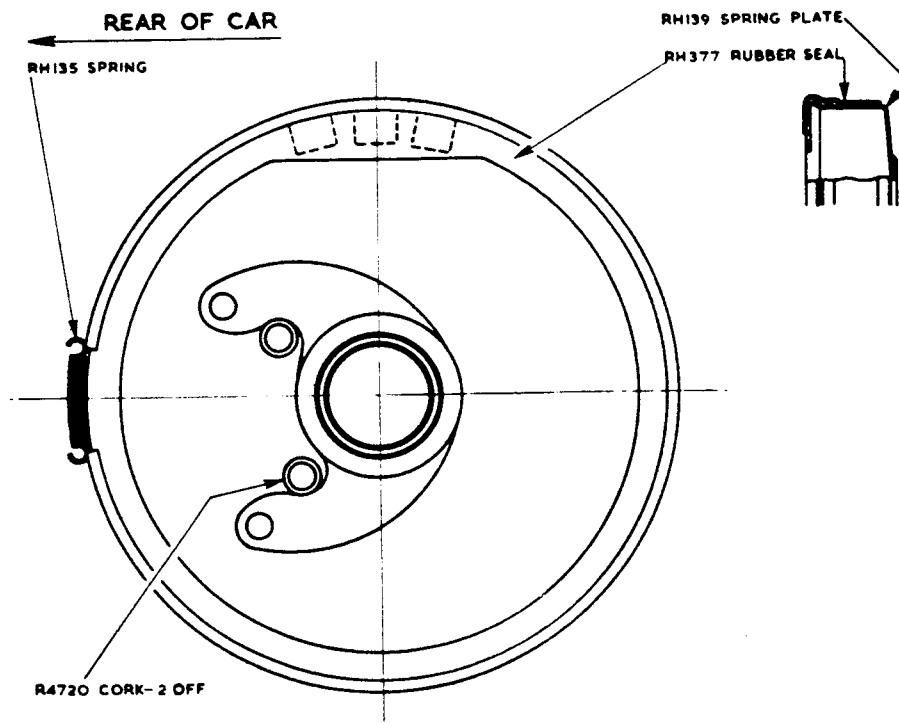

FIG.4.

PARTS REQUIRED.

Rubber Seal	RH.377.	1 off.
Protector Spring	RH.135.	1 off.
Sealing Cork	R.4720.	2 off.





MODEL BENTLEY MARK VI

- 6 -

The time permitted for fitting the corrugated washer is  $3\frac{1}{2}$  hours, and the time for fitting the rubber seal is also  $3\frac{1}{2}$  hours, but where both modifications are done together the time allowed is 4 hours.



MODEL

BENTLEY MARK VI

FOR INFORMATION:LOCKHEED FRONT BRAKE EXPANDERS & MASTER CYLINDER(CHASSIS NO.B-1-GT ONWARDS AND CONTINENTAL)1. FRONT BRAKE EXPANDERS:

Some instances have occurred of brake troubles which have been due to leakage of brake fluid from the internal front brake expanders. Upon investigation, the bores of the expanders were found to be scored or corroded, while some of the rubber cups (Fig.1) were found to be devoid of radial pressure due to being a slack fit in the bores; this will permit air ingress to the hydraulic system causing subsequent complaints of servo judder, inefficient brakes or brakes pulling to one side. Excessive loss of brake fluid from the system can of course render the brakes inoperative.

If upon removal of the front brake drums, there are signs of brake fluid leakage, the expander should be removed for examination.

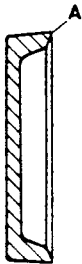

Fig.1. Section-  
Rubber cup.  
Expander.

The removal, dismantling and re-assembling of the expanders is described in Section J, Sub-Section RDJ-5 of the Rolls-Royce Silver Dawn Workshop Manual.

- (i ) If an expander bore is scored and/or corrosion pitted, a new unit should be fitted. Retailers in the United Kingdom only, should return the original one to the London Service Station. Where a bore has only slight scratch markings, it should be polished with Durex abrasive paper, Grade No.240. It is essential that a bore has a perfectly smooth finish and free from corrosion marks.
- (ii ) Fit two new rubber cups (RG-5254) which should be a light push fit in the bore and renew the rubber dust covers (RG-6183) if deteriorated.

2. MASTER CYLINDER:

There have also been cases of ingress of air into the system due to non-sealing of the rubber valve washer 'F' Fig.2. against the face 'D' at the outlet end of the cylinder. The sealing lip 'A' Fig.1. of the rubber cups in the front brake expanders is normally held in firm contact against the bore of the expander by a residual hydraulic pressure of about 12-14 lbs. per sq/in. created by the spring loading of the return valve illustrated in Fig.2. Should this valve fail to maintain the hydraulic pressure, air may enter past the cups of the expanders owing to the comparatively low pressure exerted by the cups themselves against the bore.

Examination revealed that the primary cause of the valve washer 'F' not seating correctly, was due to the diameter of the face 'D' of the master cylinder being too small, causing the valve washer to make heavy contact with the rough un-machined tapered sides 'C' of the cylinder resulting in excessive wear and distortion of the valve washer.



MODEL BENTLEY MARK VI

- 2 -

The afore-mentioned also causes servo judder, inefficient brakes or brakes pulling to one side.

Where faulty operation of the master cylinder itself is suspected, it should be removed for examination.

The removal, dismantling, re-assembling and a general description of the master cylinder is detailed in Section J, Sub-Section RDJ-4 of the Silver Dawn Workshop Manual.

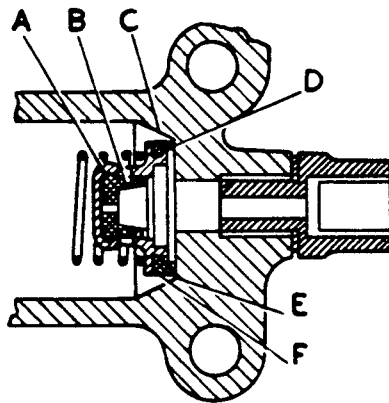

Fig.2. Section-Return valve assy.  
master cylinder.

- (i ) Fit a new rubber washer 'F' (RG-7043) and a rubber cup 'B' (CD-130) to the valve body 'A'. Place the coil spring on to the valve and enter into the cylinder and check that the valve assembly has a diametrical movement of approximately 0.020" (0.50 m/m) to ensure that there is sufficient clearance between the outer diameter of the valve washer at point 'E' and the cylinder.

If the valve assembly cannot be moved as above, it will be necessary to fit a new master cylinder. Retailers in the United Kingdom only, should return the original one to the London Service Station; this also applies if the cylinder bore is scored or corrosion pitted. Where a bore has only slight scratch markings, proceed as described for a front brake expander.

- (ii ) Fit a new rubber master cup (R-3952) which should be a light push fit in the bore.
- (iii) Fit a new rubber secondary cup (R-3951) to the rear end of the piston.
- (iv ) Renew the rubber dirt excluder (RG-7028) if deteriorated and re-assemble the master cylinder in accordance with Para.4. of Sub-Section RDJ-4.



MODEL BENTLEY MARK VI

CATEGORY 2.REPLACEMENT OF SERVO PUSH ROD  
BELLCRANK LEVER.

On left hand drive vehicles the brake linkage to the servo differs from right hand drive models in that the brake pedal is not linked direct to the servo, but to a bellcrank lever in line behind it, which transmits fore and aft motion transversely across the car to another bellcrank lever in line behind the servo, which in turn transmits the motion forward to operate the servo via a push rod.

When the brakes are applied and released, the servo operating levers are rocked back and forth, raising and lowering the end of the servo push rod, but at the same time the clevis joint between the servo push rod and the bellcrank lever permits only rotary movement to the bellcrank lever about a vertical axis, and does not allow for vertical movement to the push rod. This consequently causes the load when braking, to strain the clevis joint, which may eventually cause fatigue failure of the servo push rod where it screws into the clevis jaw.

In order to overcome this possibility, a new bellcrank lever UG.2280 having a semi-universal bearing for the push rod clevis pin, is to replace the original lever.

The recommended manner of fitting the new bellcrank lever is firstly to remove the split pin from the servo push rod clevis joint and disconnect the clevis jaw. The bellcrank can then be rotated so that the split pins in the clevis joint of the pull rod from the other bellcrank lever, and in the pivot of the bellcrank lever can be removed, allowing the bellcrank pull rod to be disconnected and leaving the bellcrank pivot pin free.

It will not be possible to withdraw the bellcrank pivot pin until the cross stay between the two bellcrank brackets is demounted by removing the two 7/16" securing nuts and bolts, and the four 1/4" B.S.F. nuts and bolts securing the bellcrank bracket to the frame are removed to allow the bracket to be displaced sufficiently for the bellcrank lever central pivot pin to be withdrawn from the top.

The bellcrank pivot pin is to be smeared with "Retinax" or similar grease, the new bellcrank lever fitted and the bracket and cross stay bolted to the frame once more. The bellcrank lever pull rod is next to be re-connected, the new clevis jaw fitted to the servo push rod, and the longer clevis pin fitted. The brake linkage is then to be finally adjusted and the three split pins fitted.



MODEL BENTLEY MARK VI

- 2 -

To identify that this modification has been incorporated, the servo push rod is to be marked with yellow paint.

The time allowed for this work is three hours.

MATERIAL REQUIRED:

Bellcrank lever assembly	UG.2280.	1 off.
Clevis jaw (servo push rod)	KB.1114/Z.	1 off.
Clevis pin (servo push rod)	RG.4405.	1 off.
Split pins	K.4643/Z.	3 off.

# Bulletin

MODEL: BENTLEY MARK VI

CATEGORY 3

SERVO MOTOR SEALING

It has been found that the effective life of the servo liner may be greatly reduced, due to contamination by oil or water from various sources.

In order to ensure the fullest possible life, the servo motor sealing has been improved on production cars. Existing cars should be modified and brought to this standard, whenever a servo is dismantled.

Where inspection of the liner shows the presence of oil, the source of oil leakage must first be ascertained and rectified.

Before re-assembling, the following modifications are required, if not already incorporated.

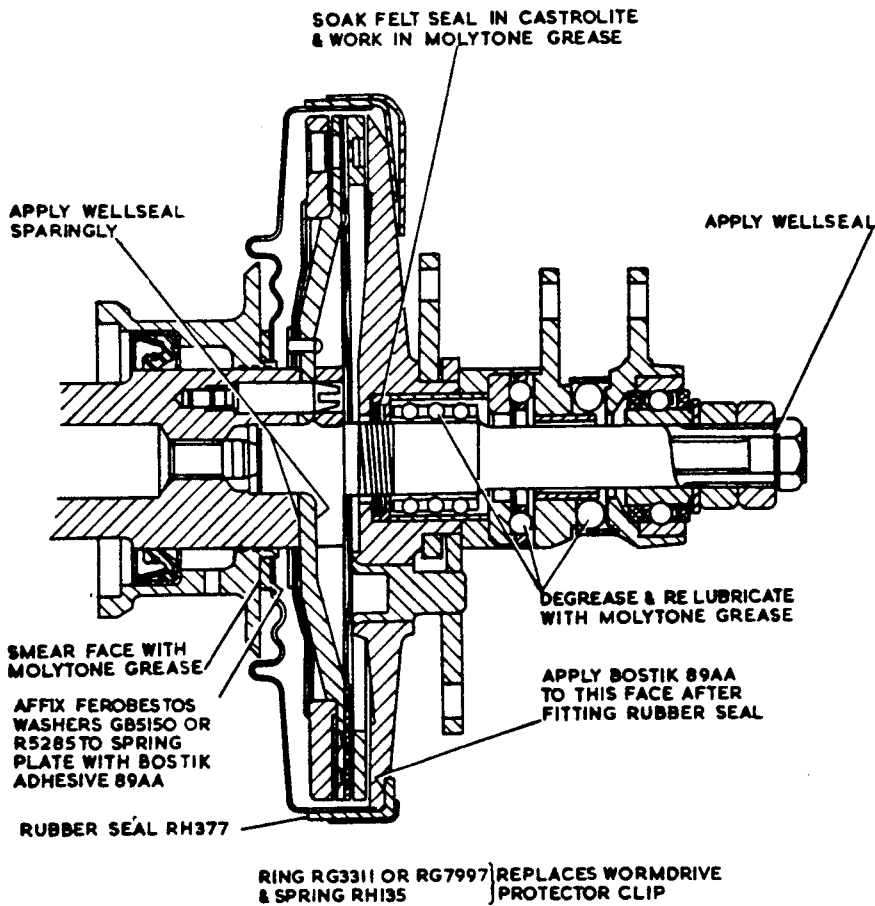

FIG. 1.

ALL COMMUNICATIONS SHOULD BE ADDRESSED TO  
 BENTLEY MOTORS (1931) LTD, 7YM'S LANE, CREWE, ENGLAND



MODEL BENTLEY MARK VI

-2-

1. Remove the water drain on the servo spring plate, this is simply done by unsweating.

Blank off the spring plate drain holes located in the rim, by filling with solder. This is best done by tinning the inside of the rim, resting the spring plate holes downwards on a sheet of asbestos, so that solder is prevented from running through and building up on the outside of the rim. The solder is then smoothed over and the spring plate repainted with a high quality air drying chassis black.

2. Degrease thrust race, operating lever cams and pressure plate ball race ensuring that they are thoroughly clean and free from grease.

Re-lubricate with Molytone Grease.

3. Renew and soak felt washer (located in pressure plate) in engine oil and lightly coat with Molytone Grease.
4. Apply Wellseal sparingly to the end face of the servo drive shaft, both sides of the centre of the inertia plate, to the end face and driving pins of the servo driven shaft and under the head of the servo retaining setscrew, after ensuring that all surfaces are free from oil or grease.

A pencil brush may be used for all application of the Wellseal.

Allow at least five minutes for air drying before assembling the joints.

5. Apply Bostik Adhesive (89AA) to one face of the Ferobestos seal and stick to the spring plate, lightly smear Molytone Grease on the outer face of the Ferobestos seal.
6. With pressure plate uppermost, place the rubber seal on top with the flap covering the ventilating slots and ease the seal over the rim edge without stretching. Hold there, easing the opposite side over the plate edge.

It is essential that the pulling is limited to the inner diameter, only, thereby preventing distortion of the outer periphery. Ease the remainder of the seal into position until the inner periphery fits closely against the machined surface.

By carefully lifting the rubber seal which overlaps the ventilating slots and machined surface, apply Bostik to the inner face of the seal, a small area at a time, until the complete circumference of the inner face has been treated in this manner.



**Bulletin**

MODEL BENTLEY MARK VI

-3-

Allow Bostik to set for approximately one hour before using the car.

7. Fit the protection ring (RG.7797 or RG.3311) with the lower rate spring (RH.135). Position the spring towards the rear of the car and not to the lowermost position as was customary with earlier cars.

Seal the ends of the brake actuating lever operating pins with 2 corks (R.4720) if open.

NOTE:

- (a) It is NOT possible to use the rubber seal more than once, nor is it possible to use the seal if it has been stretched in an unsuccessful attempt to fit it.
- (b) Trichlorethylene applied to the Bostik will assist easy separation when required.

PARTS AND MATERIAL REQUIRED

<u>Description</u>	<u>No.Off.</u>
Bostik Adhesive (89AA)	
Molytone Grease	
Wellseal	
Rubber Seal RH.377	1
Protector Ring RG.7797 or RG.3311	1
Protector Ring RH.135	1
Sealing Corks R.4720	2 (if required)
Ferobestos Washer GB.5150 or R.5285	1
Felt Seal D.54399	1

APPLICABLE TO ALL:-

Bentley Mark VI  
 Bentley 'R' Type  
 Rolls-Royce Silver Dawn  
 Rolls-Royce Silver Wraith

The time allowed for this modification is 4½ hours.

FOR INFORMATION.SERVICE REPLACEMENT BRAKE DRUMS.

A service replacement brake drum scheme has been inaugurated. There are now two sizes of drums available, namely, 'Standard' and 'Oversize'. These will be supplied to Retailers against worn drums returned for reconditioning.

The cost of the 'Oversize' replacement drum will be 66. 2/3% of the price of the 'Standard' drum.

Credit of the above mentioned percentage, less the cost of reconditioning, will be allowed on worn drums returned, providing they can be reground within the prescribed limits.

Drums which do not conform to these limits have no salvage value and consequently will be scrapped.

Part numbers.

Standard Replacement Brake Drum Part No.	Oversize Replacement Brake Drum Part Nos.
RG. 3212	x RH. 190
RG. 6018	RH. 191
RG. 6780	RH. 192

x RH. 190 will be supplied against all worn drums returned from post-war cars before:-

'R' TYPE BENTLEY Chassis No. B-1-GT

i. e. Before the steering geometry modification was introduced as a standardisation.

RH. 191 front brake drum and RH. 192 rear brake drum will be supplied to all cars produced after and inclusive of the above mentioned chassis number and prior to the introduction of the 'S' Series.