



MODEL BENTLEY MARK VI

CAR HEATER SYSTEM.

A modification has been introduced to the car heater system to obviate the possibility of damage to the heater matrix due to excessive water pressure.

Under certain conditions, the rate of flow from the cylinder head is greater than that which will pass through the matrix and gives rise to high local pressure. A restrictor disc fitted into the feed pipe controls the flow to a safe figure.

The attached drawing shows the position of the disc and the method of fixing.

This modification has been embodied during assembly on all cars with the exception of a small number in regard to which the Retailers affected will be notified.

No general retrospective action is therefore necessary.

Restrictor Disc is: Part No: RE. 5767.

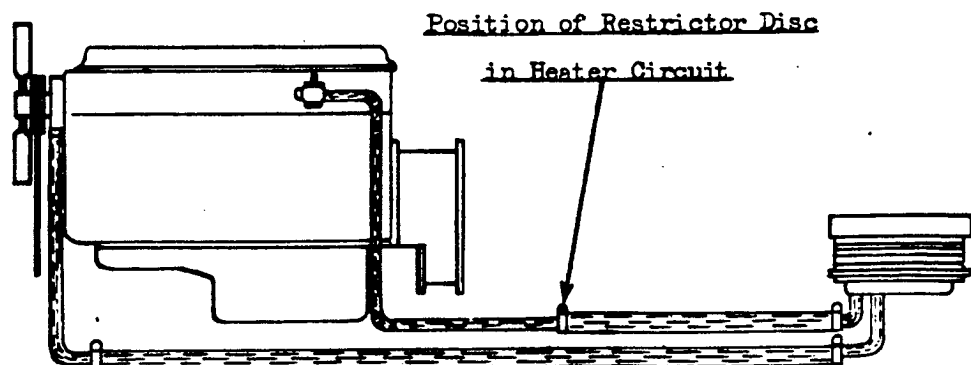
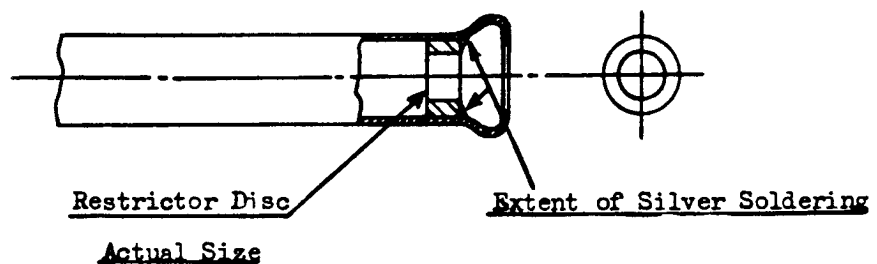

Bulletin

MODEL: BENTLEY MARK VI

RADIATOR STEAM VALVE.

The coolant system is at present pressurised to approximately 4 lbs per sq.in. pressure by means of a steam valve situated on the radiator header tank where the steam escape pipe is attached to the radiator. It has been decided in future to operate the coolant system at atmospheric pressure and the ball and spring inside the steam valve housing are to be removed forthwith on all cars in service.

The valve is readily accessible by unscrewing the hexagon plug on top of the header tank at the point of attachment of the steam pipe. When the ball and spring have been removed, a spot of white paint should be applied to the steam pipe close up to the steam valve chamber to denote that the alteration has been carried out.

Will all Retailers please take action to carry out this alteration on all cars in their territory at the first opportunity.

Will Retailers and Service Depots please notify the London Service Depot of the chassis numbers whenever this alteration is carried out. If any cars are not available in their respective territory, special arrangements will be made to deal with the matter if the London Service Depot is advised.

Bulletin

MODEL: BENTLEY MARK VI

FOR INFORMATION:FITTING OF ADDITIONAL INTERIOR CAR HEATER.
(Incorporating Improved Demisting & Defrosting)GENERAL:

Retailers are advised that an additional interior car heater is now available for fitting to Bentley Mk.VI Standard Saloons in service as a chargeable improvement in cases where the output of the existing underseat heater is considered insufficient to meet conditions of extreme cold.

This additional heater is fitted to the centre of the dash behind the facia panel, and part of its hot air output is directed into both of the demisting ducts for defrosting and demisting purposes, thus making the use of the existing electrically operated heater unit in the right-hand duct unnecessary.

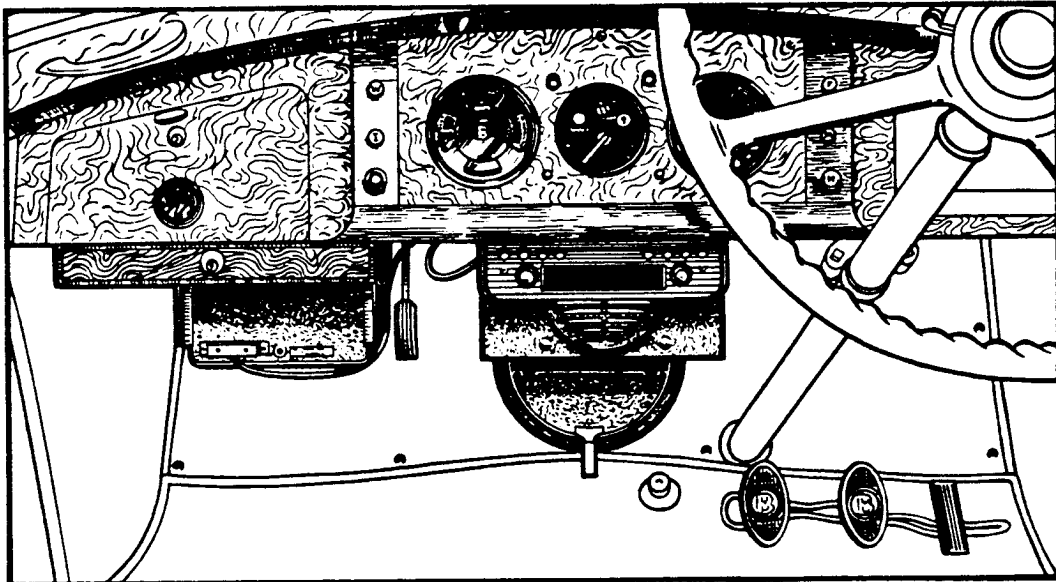

FIG. 1. FINISHED VIEW OF HEATER IN POSITION.

A separate rheostat switch is included for the control of this additional heater, while a foot operated trap door is incorporated in the heater cover for the purpose of cutting off the direct hot air flow into the car interior when demisting only is required.

The above illustration shows the position of the heater when installed in a car.

All the necessary fitting instructions, including the essential drilling and wiring diagrams, are given in this leaflet. The cost of the components necessary for this installation may be obtained from the London Service Station.

- 2 -

PROCEDURE FOR FITTING THE ADDITIONAL HEATER.General Description of Installation:

The operation of the additional heater is identical to that of the existing underseat heater, and the water circulation is effected in series with this as shown in Fig.2, i.e., from the cylinder head to the additional heater, thence to the underseat heater, and from there, returning to the engine.

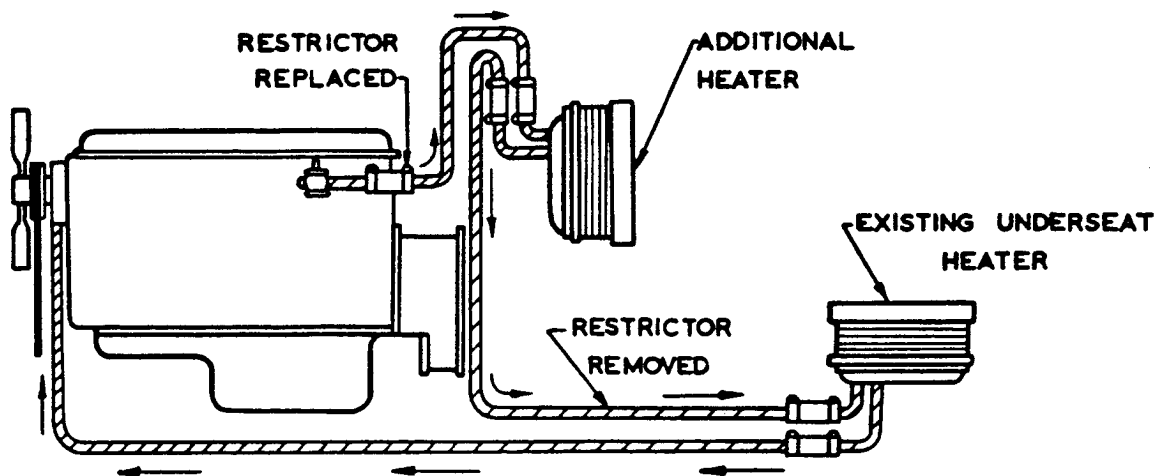

FIG. 2. GENERAL LAYOUT OF WATER CIRCULATION.

The dash heater embodies a hot air take-off which is connected to the existing air silencers to supply heater air to the demisting vents. As shown in the illustration on Page 1, a horizontally hinged door is fitted to the heater cover, its purpose being to cut off the supply of direct heat into the interior of the car when demisting only is required.

With this additional heater installed, the demister motor, blower and electrically operated heating element in the right-hand air duct are no longer required, and these components and their wiring must be removed.

The Demister Switch (M) is also removed, and a separate rheostat control switch for the dash heater fitted in its place. The existing Defroster Switch (F) is disconnected and left in position for future use.

In order to fit the dash heater behind the radio, it will be necessary to remove the power pack fitted to the back of the receiver, re-positioning this behind the tool tray as seen in illustration on Page 1. In addition, the radio mounting tray will have to be modified to allow full clearance for the demister adaptor at the top of the heater cover.

When installing the additional dash heater, it is recommended that the following sequence of fitting operations are adhered to:-

- (a) Removal of the radio receiver, demister motor and blower, electrical heater element and wiring.

Bulletin

MODEL : BENTLEY MARK VI

- 4 -

2. Pull back the felt or Sepak insulation sufficiently to bare the metal dash for marking off and drilling as shown in Fig. 3.
NOTE: Due to the fact that this installation will be carried out with the engine in situ, all marking off and drilling of the dash will require to be made from the interior of the car.
3. Refit the insulating material and drill this to correspond with the holes drilled in the dash.
4. Enlarge the holes drilled in the insulating material to 0.500" dia. to allow sufficient clearance for the heater fixing stud shoulders.
5. Mark out and cut a circular recess 4.25" dia. x 0.300" deep in the top face of the insulating material, taking care to see that the three holes already drilled for the fixing screws are all within this diameter.
6. Refit the carpet and cut this to correspond with the recess and holes in the insulation.
7. Fit the heater as follows:-
 - a) Remove the heater cover.
 - b) Holding the heater matrix and back plate together, insert the two bent pipes into the two 0.750" dia. holes, coincide the three integral fixing studs at the back of the base plate with their appropriate holes drilled in the insulation and dash, and press the heater in position. Secure by tightening the nuts on the engine side of dash.
 - c) Fit the rubber grommets round the bent pipes in the dash and then refit the heater cover, ensuring that the foot control for the trap door is at bottom dead centre.
8. Fit the "Y" shaped demister adaptor to the top half of the heater.
9. Fit the power pack bracket to the dash, using the two countersunk-headed setscrews provided. After tightening the nuts on the engine side of the dash, cut off all excess threaded portion of the screws projecting beyond the nuts.
NOTE: One arm of this bracket will be found to have a 0.3125" dia. hole drilled through to accommodate the connecting lead clip. When fitting the bracket, this arm should be towards the centre of the car.

C. DETACH POWER PACK FROM BACK OF RECEIVER AND FIT TO BRACKET:

1. Remove the four setscrews securing the power unit cover, and lift off the cover.
2. Remove the three setscrews securing the power unit to the back of the receiver and remove the power unit. A thin bladed screwdriver may be used for this, but great care should be exercised during this operation.
3. Replace the power unit cover.

ALL COMMUNICATIONS SHOULD BE ADDRESSED TO

BENTLEY MOTORS (UK) LTD. PYMS LANE

SECTION

4. Slide the power unit into the bracket with the female plug pointing both downwards and towards the centre of the car, and secure the unit in position by means of the two shouldered retaining bolts. These bolts should be passed through the bottom bolt holes in the two arms, i.e. the holes nearest to the back plate of the bracket and the rubber grommets fitted to centralise the bolts in the holes.
5. Fit the appropriate connecting lead plug into the left-hand bottom corner of the power unit, (See Fig.1), and secure this in position by means of the two metal thread setscrews provided through the plug flanges. Prior to fitting this plug however, care should be taken to ensure a good earth connection by cleaning the plug flanges and front face of the power unit in the immediate vicinity of the screw holes.

D. FITTING OF WATER CONNECTIONS:

1. Install the water connections as shown in Fig. 4.

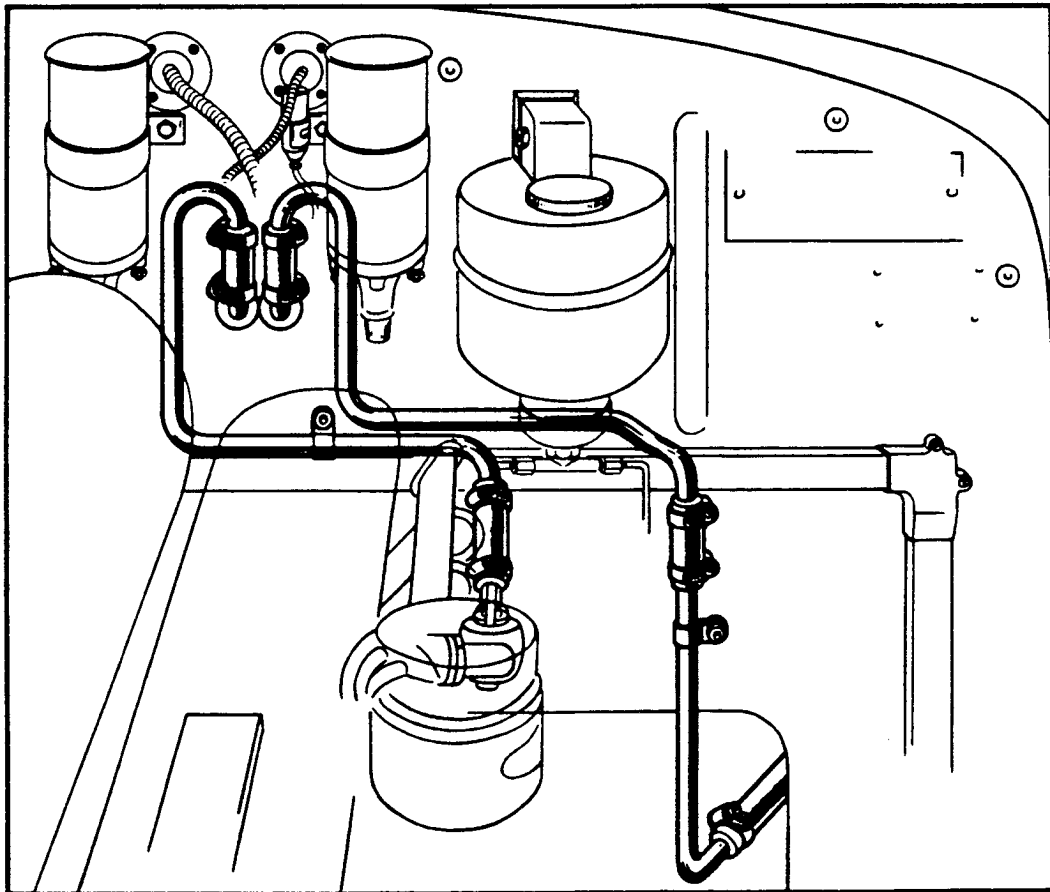

FIG. 4. INSTALLATION OF THE WATER CONNECTIONS.

The existing pipe between the cylinder head isolating tap and under-seat heater should be removed, and the short angled pipe for the right-hand dash heater connection substituted in its place. The original union nut on the

Bulletin

MODEL: BENTLEY MARK VI

- 6 -

isolating tap should be used again, while the retaining clip for the angled pipe should be fitted to either of the two upper heater fixing studs to suit the run of the piping.

On certain Bentley chassis, the spare ignition coil is carried below the metal cable conduit on the left-hand side of the dash and this may be found to interfere with the "down-run" of the piping between the dash heater and the underseat heater. In cases such as these, this spare coil may be moved 1.00" further to the left in order to allow sufficient clearance for the pipe. The retaining clip for the pipe should be mounted on the existing fixing stud of the ignition coil above the engine.

Where both the ignition coils are mounted on the dash side by side above the engine, the existing toe-board setscrew nearest to the "down-run" of the underseat heater feed pipe should be removed and replaced by the longer screw provided, and the threaded portion of this longer screw projecting beyond the hank rivet on the engine side of the dash should be used for mounting the retaining clip.

E. FIT RHEOSTAT SWITCH TO INSTRUMENT PANEL AND WIRE TO HEATER:

1. Remove the instrument panel facia board.
2. Remove the demister switch (M) from the instrument panel, and enlarge the existing hole in the panel to accommodate the rheostat switch. Fit the rheostat switch.
3. Enlarge the original demister switch hole in the facia board to suit the shank of the rheostat switch.

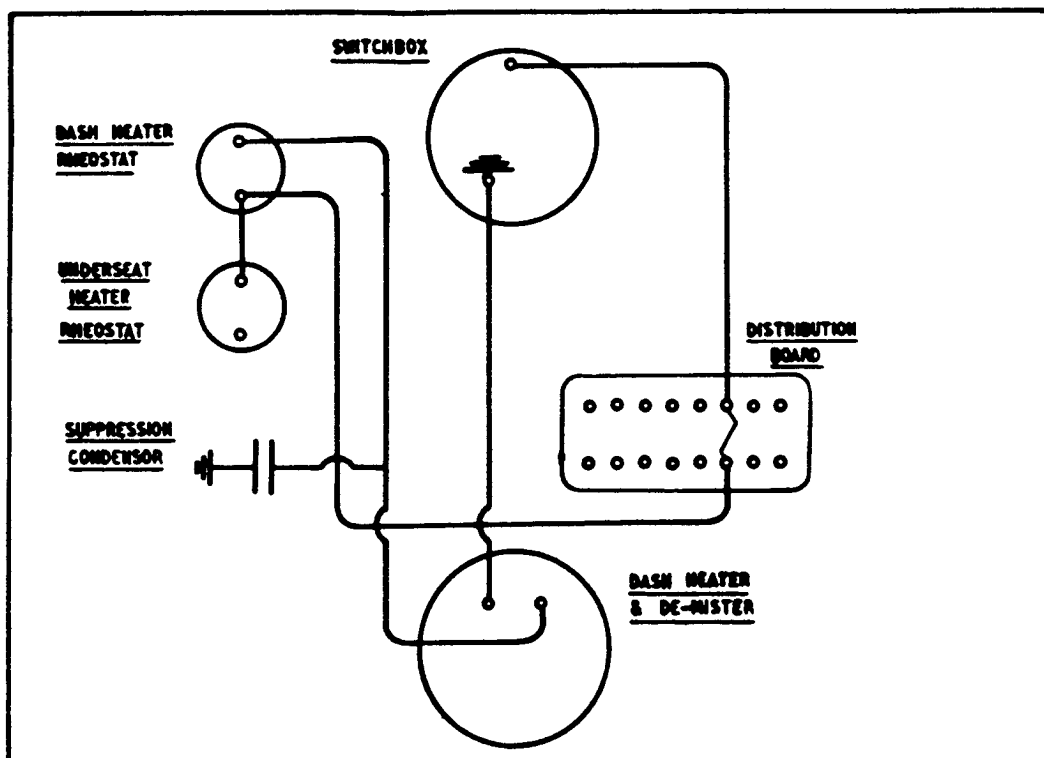

ALL COMMUNICATIONS SHOULD BE ADDRESSED TO
BENTLEY MOTORS (1937) LTD., 57/58 LANE, CRENSHAW, ENGLAND.

- 7 -

4. Run the earth lead from the dash heater motor under the carpet and connect up to the switchbox earth connection as shown in Fig. 5.
5. Connect the Suppression Condensor supplied to the dash heater feed wire, and then secure the condensor to the demister motor mounting bracket by means of the cheese-headed setscrew supplied.
6. Connect the dash heater and original demister switch feed wires to the rheostat switch.
7. Refit the instrument panel facia board.

F. MODIFICATION OF THE RADIO MOUNTING TRAY & COMPLETION OF INSTALLATION:

1. Reconnect the air silencers to the demisting air vent tubes and connect their free ends to the "Y" shaped adaptor on the dash heater by means of the two wire wound flexible tubes supplied. When fitting these, ensure that the longer tube is fitted to the right-hand side of the adaptor.
2. Cut away the rear of the mounting tray as shown in Fig. 6, and weld on a stiffening rib similar to that already on the rear of the tray.

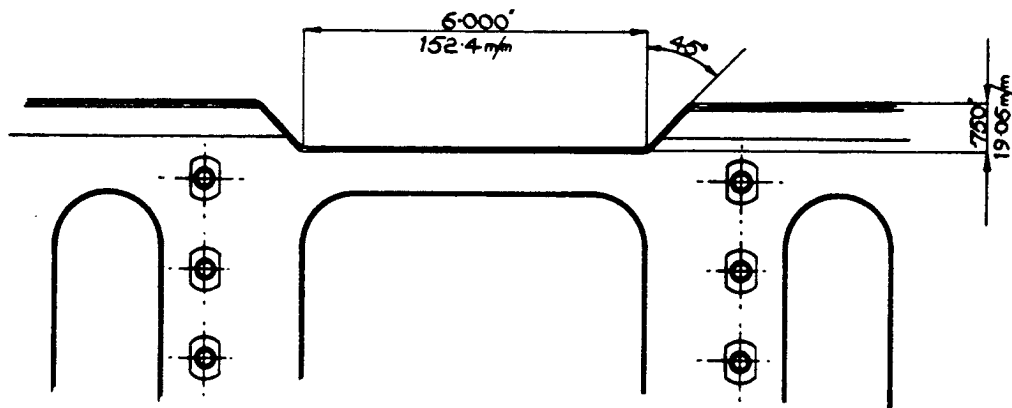

FIG. 6. MODIFICATION TO RADIO MOUNTING TRAY.

3. Refit the radio mounting tray, ensuring that the plastic wiring conduit is under the right-hand flexible tube.
4. Fit the power unit lead plug into the back of the receiver and refit the receiver on its mounting tray. Should there be insufficient clearance between the heater cover and the receiver, the receiver may be mounted 0.250" FORWARD on its mounting tray by drilling additional 5/16" dia. holes in the flange of the tray to suit the fixing studs when in this alternative position.
5. Clip the power unit lead to the right-hand arm of power unit mounting bracket and arrange this to present a neat appearance.

Bulletin

MODEL: BENTLEY MARK VI

- 8 -

LIST OF MATERIAL REQUIRED.

R.4071	Split Bracket Assy. c/w Setscrews etc. - Power Unit.	1 Off.
R.4088A	Pipe Assy. - Cylinder Head Isolating Tap to Hose Conn.	1 "
R.4089	Pipe - Underseat Heater Feed.	1 "
R.4090	Pipe - Dash Heater Feed.	1 "
R.4091	Pipe - Dash Heater Outlet.	1 "
R.4092	Hose Connection - 2.750" long - Water Pipes.	3 "
R.4093	Hose Connection - 4.500" long - Water Pipe-Cylinder Head Tap.	1 "
R.4115	Flexible Hose Conn. - 4.00" long - R.H. Air Silencer.	1 "
R.4116	Flexible Hose Conn. - 2.50" long - L.H. Air Silencer.	1 "
R.4118A	Dash Heater Assy.	1 "
R.4129	"Y" Piece Adaptor - Dash Heater.	1 "
R.4132	Clip, Retaining - Dash Heater Feed Pipe.	1 "
RE.4750	Jubilee Clips - Size O.	8 "
RE.6231	Clip, Retaining - Dash Heater Outlet Pipe.	1 "
RD.3434	Power Lead Clip.	1 "
RD.3441	Rheostat Switch.	1 "
R.4073	Power Lead.	1 "
RD.4226	Suppression Condensor.	1 "
R.4141	Countersunk - Headed Bolts - Split Bracket Assy.	2 "
R.4142	Nuts - For Above.	2 "
K.9009	Spring Washers - For Above.	2 "
CS.30200	Screw - For Securing Suppression Condensor	1 "
K.2019	Setscrew - For Replacing Toeboard Setscrew	1 "
K.4008	Nut - For Above.	1 "
K.9008	Spring Washer - For K.2019 & CS.30200.	2 "

When an additional dash heater is installed in an existing Bentley Standard Saloon, the following standard fittings become redundant, and should be discarded:-

Blower & Motor - Demister
 Breeches Piece - Demister Blower.
 Connection - Rubber Hose - Demister Air Silencers.
 Mounting Plate - Demister Blower.
 Distance Piece - Demister Blower.
 Heater Element.
 Push/Pull Switch - Demister.
 Pipe Connection - Cylinder Head Tap to Underseat Heater.

Bulletin

MODEL: BENTLEY MARK VI

FOR INFORMATIONRECOMMENDED ALTERNATIVE WATER PUMP BEARING ASSEMBLIES.

The following information is given as a means of guidance to Retailers should it become necessary to overhaul an existing Bentley water pump in service.

Originally all water pumps incorporated either a Fischer SFM or New Departure bearing assembly in production. The former assembly, however, proved unsuitable in service, and is now obsolete, having been superseded by the current improved Fischer D2 type assembly. The New Departure, on the other hand, has proved satisfactory, and is still listed as a recommended alternative replacement. A third alternative is the Hoffman bearing assembly which was introduced in order to augment supplies.

Although in many cases the original type Fischer SFM assembly has been replaced in service, it is believed that there are still a number of water pumps operating with this bearing assembly. Retailers are advised, therefore, that in the event of a water pump being dismantled for an overhaul, to examine the existing bearing assembly, and if found to be a Fischer SFM type, to replace it by one of the recommended current alternatives mentioned above.

As an aid to recognition each bearing assembly is illustrated below, the individual characteristics being stressed in each case.

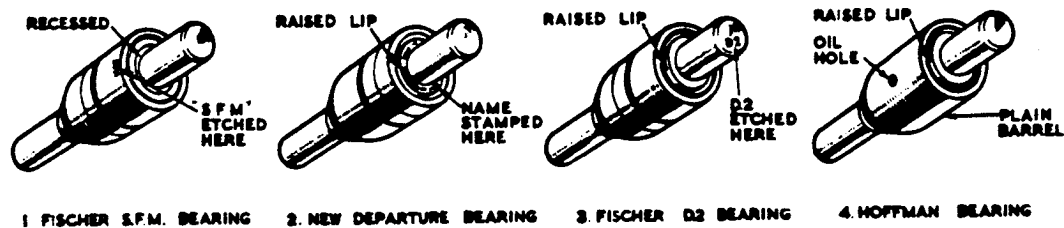

In addition it is recommended that Retailers also make a check of their existing stocks of replacement water pump bearing assemblies, and if found to hold any Fischer SFM type assemblies, to return these to the London Service Station, where they will be exchanged free of charge.

Bulletin

MODEL BENTLEY MARK VI

FOR INFORMATIONRECOMMENDED ALTERNATIVE WATER PUMP BEARING ASSEMBLIES.

The following information is given as a means of guidance to Retailers should it become necessary to overhaul an existing Bentley water pump in service.

Originally all water pumps incorporated either a Fischer SFM or New Departure bearing assembly in production. The former assembly, however, proved unsuitable in service, and is now obsolete, having been superseded by the current improved Fischer D2 type assembly. The New Departure, on the other hand, has proved satisfactory and is still listed as a recommended alternative replacement. A third alternative is the Hoffman bearing assembly which was introduced in order to augment supplies.

Although in many cases the original type Fischer SFM assembly has been replaced in service, it is believed that there are still a number of water pumps operating with this bearing assembly. Retailers are advised, therefore, that in the event of a water pump being dismantled for an overhaul, to examine the existing bearing assembly, and if found to be a Fischer SFM type, to replace it by one of the recommended current alternatives mentioned above.

As an aid to recognition each bearing assembly illustrated below, the individual characteristics being stressed in each case.

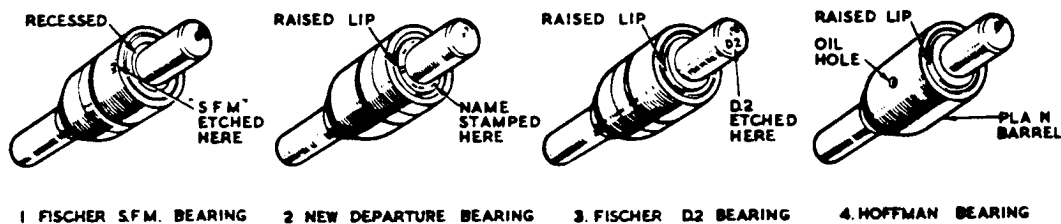

In addition it is recommended that Retailers also make a check of their existing stocks of replacement water pump bearing assemblies, and if found to hold any Fischer SFM type assemblies, to return these to the London Service Station, where they will be exchanged free of charge.

Bulletin

MODEL: BENTLEY MARK VI

FOR INFORMATION.IMPROVED DEMISTING SYSTEM.(SUPERSEDES PREVIOUS SERVICE BULLETIN BB-79)

Retailers are advised that the improved type demister system fitted in production to current models is now offered as a chargeable improvement for incorporation on earlier Bentley MK.VI cars in service should owners desire it.

As a result of further investigation and development this new system is capable of keeping the windscreen clear under much more severe conditions than was possible on earlier cars, and it has been adapted so that it may be fitted in place of either the original electrically heated under scuttle system or the later radiator heated type shown in Figs. 1 & 2.

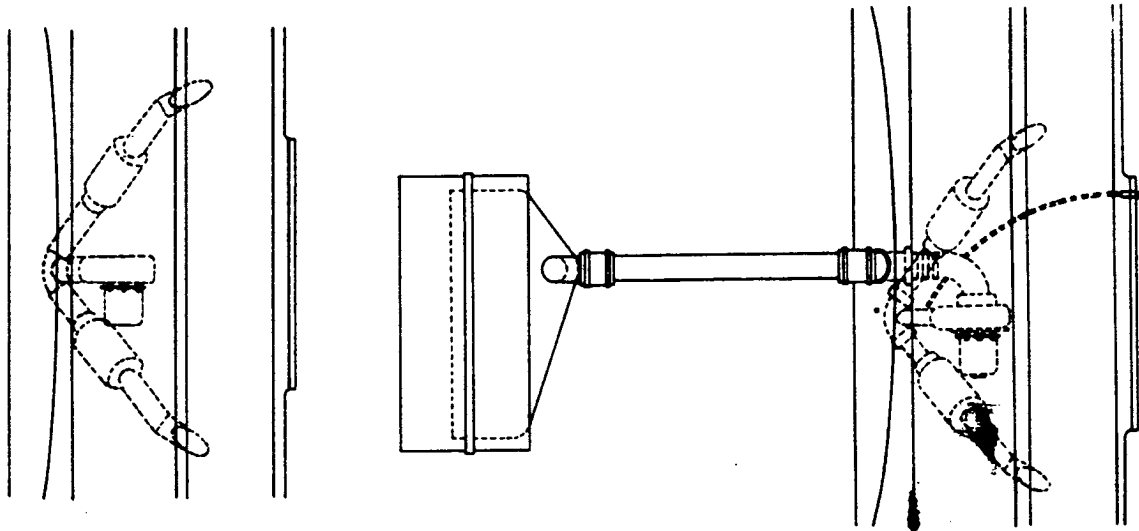

FIG. 1. ORIGINAL SYSTEM.

FIG. 2. RADIATOR HEATED SYSTEM (INTERMEDIATE TYPE).

The improved type demister system is shown in Fig. 3, and it will be seen that it is, in general appearance and operation, similar to existing types.

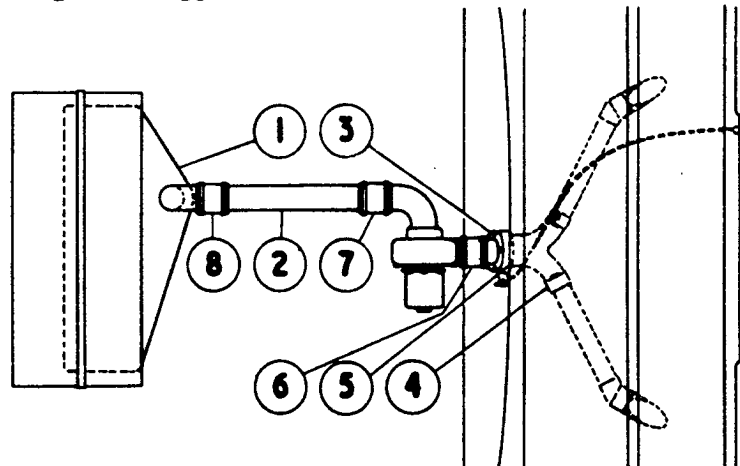

FIG. 3. IMPROVED TYPE DEMISTER SYSTEM.

ALL COMMUNICATIONS SHOULD BE ADDRESSED TO
BENTLEY MOTORS (1931) LTD., PYM'S LANE, CREWE, ENGLAND

Bulletin

MODEL: BENTLEY MARK VI

- 2 -

It is emphasized that no demisting apparatus will operate efficiently unless both outlet ducts at the windscreen are free from obstruction, and it is, therefore, of primary importance that these are tested, and if necessary, corrected in the manner detailed later in this leaflet during assembly. It is also of equal importance that neither the run nor the shape of the conduits and tubing are altered in any way, but are kept as close as possible to the illustrations given herein.

A list of material required is appended, and the time for the installation will be approximately 16 man hours.

FITTING PROCEDURE.

- A. NOTE: These instructions refer ONLY to cars fitted with the original electrically heated under scuttle air intake system (See Fig.1).
- 1) Fit the metal air duct (1, Fig.3) below the radiator header tank as shown, securing this to the rear flange of the tank by means of the two clips and then tightening the hinged strap round both the tank and the duct. (N.B. To fit the strap, first remove the hinge pin, pass one of the disconnected ends of the strap over the top of the tank and under the overflow pipe, and then refit the pin and tighten up).
 - 2) Disconnect the radio aerial lead, power feed and bonding tape (if fitted) and then remove the radio holding setscrews and take down the radio. Unscrew the threaded ring which positions the speedometer trip control, remove the six holding setscrews, and take down the radio mounting tray.
 - 3) Remove the wooden facia centre panel:-
 - a) Remove the three countersunk screws along the top of the panel.
 - b) Remove all the push/pull switch knobs by turning these to the left. (The rheostat switch knob is secured with a grub screw).
 - c) Remove the two countersunk screws along the lower edge of the panel. On earlier models these are removed in the normal manner, but on later cars they should first be turned to the right to release the panel retaining clips at the back. (The screws which should be turned to the right to release are countersunk about one inch into the woodwork, while the alternative type are considerably shallower).
 - 4) Disconnect the demister motor wiring, air silencers and flexible duct connections under the scuttle, and then remove the motor.
 - 5) Remove the four setscrews retaining the metal speedometer grommet retaining ring on the engine side of the dash, disconnect the cable from the instrument and then withdraw the cable, rubber grommet and metal ring into the engine compartment. Drill out the existing Hank rivets round the original cable aperture, enlarge this to 1.875" dia., and then drill four equally spaced holes 0.201" dia. round the hole as shown in Fig. 4.

ALL COMMUNICATIONS SHOULD BE ADDRESSED TO

BENTLEY MOTORS (1931) LTD, FVNT LANE, CREWE, ENGLAND

Bulletin

MODEL: BENTLEY MARK VI

- 3 -

- 6) Refit the speedometer cable through the dash by marking off and drilling a hole 1.00" dia. at a point 4.600" directly below the centre of the left-hand aperture carrying the thermometer capillary tube as shown in Fig. 4.

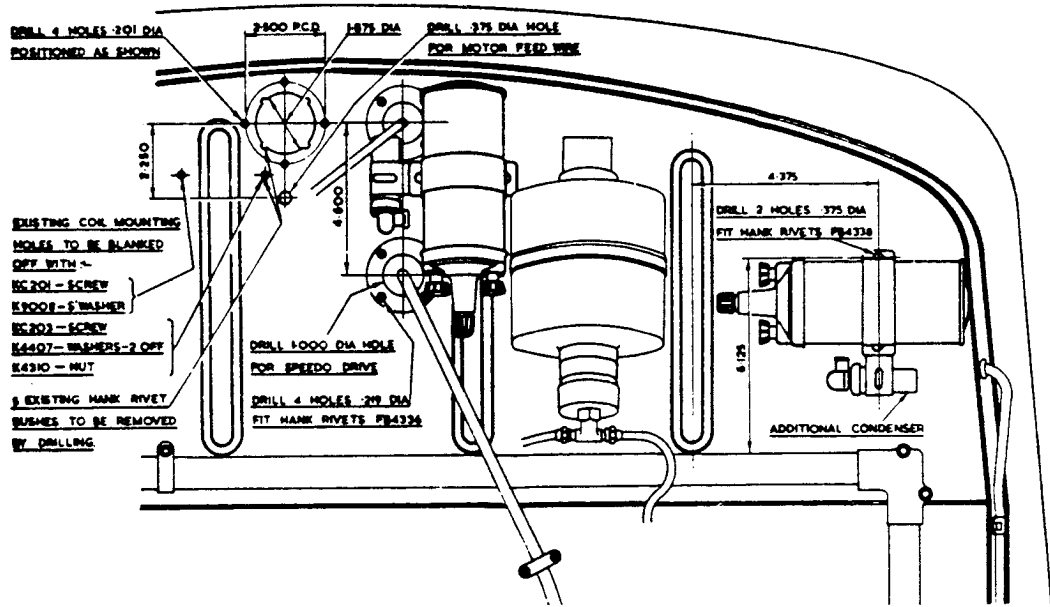

FIG. 4. INSTRUCTIONS FOR DRILLING DASH.

With the existing metal ring offered up over the hole, mark off the relative positions for the four retaining setscrews, and then drill the dash accordingly to accommodate the Hank rivets. Fit these from the driver's side. Pass the cable through the aperture and connect up to the instrument, position the rubber grommet in the hole and fit the metal ring, securing this with the original four setscrews.

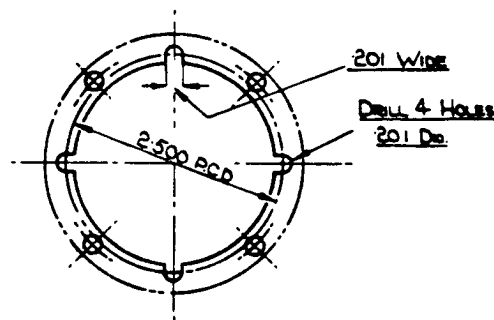

FIG. 5.

NOTE: A number of chassis between B-2-DA and B-191-DZ inclusive have the speedometer cable repositioned and an air duct aperture in the dash already cut and blanked in production.

In such cases it will only be necessary to remove the blanking plate, and then drill the four 0.201" dia. holes for the demister motor support tube retaining bolts as shown in Fig. 5.

Bulletin

MODEL : BENTLEY MARK VI

- 4 -

- 7) On chassis where both ignition coils are mounted side by side on the dash above the engine, the right-hand coil should be removed and then refitted on the left-hand side below the Chassis Name Plate as shown in Fig. 4, using the two Hank rivets provided. Fit the additional radio suppressor below the coil as shown, and connect the wire to the INPUT (or lower) terminal. Drill out the original left-hand coil bracket Hank rivet bush, and then drill another hole in the position shown for the demister motor feed wire grommet.
- 8) Fit the demister motor support tube (3) breeches piece (4) and throttle barrel (5) as shown in Fig. 6, using the four 2 B.A. bolts and washers supplied.

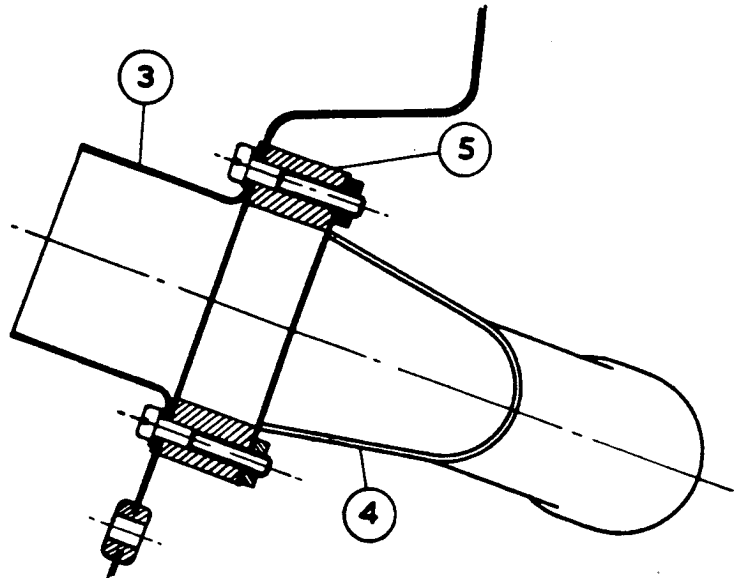

FIG. 6. FITTING OF SUPPORT TUBE, BREECHES PIECE AND THROTTLE BARREL.

- 9) Remove the existing Defroster Switch (F) from the metal instrument panel and fit the threaded end of the stop valve control inner cable into the knob of the switch. Fit the corresponding end of the outer cable into the existing switch aperture in the panel, and then mark off and cut the cable to fit into the cable clip on the throttle barrel. Care should be taken to ensure that a full sweep of cable has been allowed for easy operation of the control, and also that the cable has been cut flush with the inside of the clip. Fit the cable into the clip and tighten up the retaining grub screw. After greasing, fit the inner cable into its outer casing, and thread the lower end through the cable eye on the swivel bolt on the control arm. Push the control knob INWARDS to within 0.125" of the "fully home" position, shut the stop valve fully, and then tighten up the grub screw on the cable eye. Cut off all but about half an inch of the surplus inner cable beyond the swivel bolt, and then work the control to ascertain whether the requisite amount of travel between the fully open and fully closed positions for the stop valve has been allowed. The

Bulletin

MODEL: BENTLEY MARK VI

- 5 -

control should operate smoothly and freely, and all necessary adjustments to the cable run and/or clip position should be carried out to obtain this condition.

- 10) Refit the wooden fascia panel, and recheck the control knob position. With the stop valve fully closed this knob should correspond with the existing Demister Switch (M) when this is in its "OFF" position. Adjust the inner cable, if necessary, to give this requirement.
- 11) Connect the breeches piece to the right and left-hand demister ducts under the scuttle, using the wire wound rubber tubing provided.
- 12) Remove the electrical heating element from the right-hand demister duct below the windscreen, disconnect both wires and withdraw these completely. Remove the existing blanking plate from the left-hand duct, and fit the two modified type cover plates provided. The oblong lock plate with the bolt attached should be first passed through the duct aperture with its length parallel to the fascia board, and then turned at right-angles. The cover plate can then be fitted and secured with the lock nut as shown in Fig. 7.

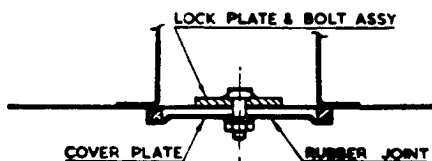

FIG. 7. MODIFIED DUCT COVERS.

- 13) Fit the demister motor to the support tube as shown in Fig. 3, using rubber hose connection (6) and two jubilee clips provided. The outlet aperture of the demister motor MUST be placed as close as possible to the support tube, but sufficient clearance should be allowed to prevent contact due to oscillation. Pass the demister feed wire through the grommet hole in the dash and connect up to the demister switch on the fascia panel.
- 14) Blank off the two holes originally used for the right-hand coil bracket using the set bolts and washers provided.
- 15) Connect the demister motor intake to the radiator heated air duct using the aluminium tube, rubber hose connections and jubilee clips provided.
- 16) Replace and refit all other parts which have either been removed or disconnected.

TEST PROCEDURE:

As previously stated on Page 2 of this leaflet the system will not operate satisfactorily if the outlet ducts at the windscreen are obstructed.

This can only be checked by creating synthetic misting conditions

- 6 -

such as the projection of steam on to the screen from an electric kettle. All the windows of the car should be closed, and the exterior of the windscreen glass kept as cool as possible by air blast, sprinkler hose or by placing the car in a cool draught. Warm the car up to normal running temperature, and, as soon as the screen is completely misted over, remove the source of supply, operate the demister, and observe the result.

Should the ducts be free from obstruction the screen will clear fairly rapidly above them, with the exception of a narrow "V" in line with the windscreen wiper spindles, which will be removed more slowly, but which should finally almost completely disappear. On the other hand, if there is any obstruction in the duct, there will be a broad permanent "V" either in the centre of the screen or in some other where this obstruction lies.

As a means of illustrating this point incorrect and correct demisting patterns are shown in Fig. 8.

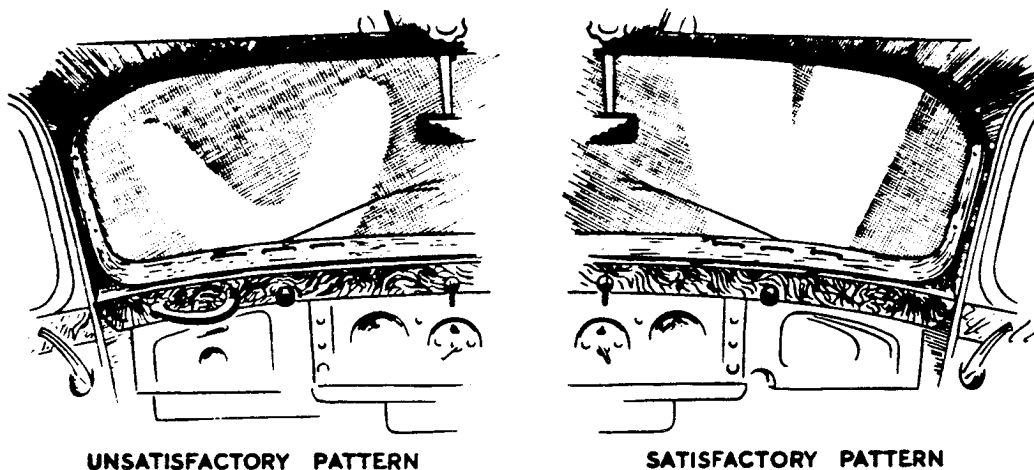

FIG. 8. DEMISTING PATTERNS ON SCREEN.

PROCEDURE FOR CORRECTING OUTLET DUCTS:

The outlet duct at the windscreen consists of two separate plates welded together at the edges and resembles an exhaust fishtail. The windscreen wiper spindle passes through a ferrule in the duct.

On earlier cars a strengthening plate was fitted in the vicinity of the ferrule, and if the clearance between the front and rear duct plates is too small, the ferrule and this plate will form a considerable obstruction in the centre of the duct. Should the air flow pattern prove unsatisfactory, examination of the duct may show that either this condition exists or possibly that the outlet aperture is too close elsewhere (the mean recommended width for the aperture is $3/16$ ").

- 7 -

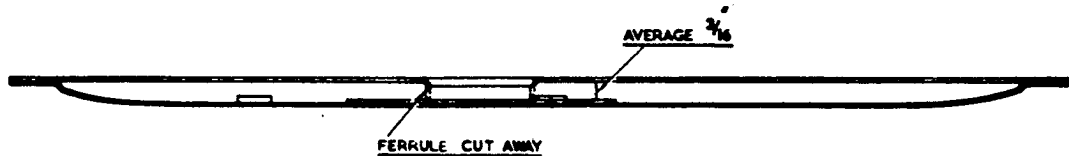

FIG. 9. RECTIFICATION OF OUTLET DUCT.

In such cases the windscreen wiper gearbox should be removed, and the ferrule sawn through the centre and the duct opened out to give an unobstructed air flow as shown in Fig. 9. It should be noted, however, that if the ferrule is cut as shown, there is a possibility of air leaking past the windscreen wiper spindle. A sealing pad may, therefore, have to be fitted between the windscreen wiper gearbox and the back of the duct.

B. FITTING PROCEDURE:

NOTE: These instructions refer ONLY to cars fitted with the intermediate type of radiator heated demister system shown in Fig. 2.

- 1) Remove the existing radiator heated air duct from below the header tank and fit the replacement supplied. Remove and then discard the existing aluminium tube.
- 2) Remove the radio set and mounting tray as described.
- 3) Remove the existing demister motor complete with its adaptor, and then remove the rubber grommet from the adaptor aperture in the dash.
- 4) Drill hole in dash for demister motor feed wire grommet as shown in Fig. 4. Fit the additional radio suppressor to the spare ignition coil as shown.
- 5) Fit the demister motor support tube, breeches piece and throttle barrel as shown in Fig. 6. (N.B. It will be necessary to drill the four 0.201" dia. holes round the duct aperture as shown in Fig. 5.) If the car is fitted with hinged flaps over the windscreen outlet ducts, the throttle barrel should not be fitted, and shorter bolts should be used to connect the support tube directly to the breeches piece with the dash in between.

NOTE: The fitting of these hinged flaps to completed cars in service is not practicable, due to the extensive alterations necessary to the windscreen fillet and the possibility of this cracking during the fitting operations.

When the throttle barrel is fitted the existing stop valve control should be cut as necessary to the required length, fitted and then adjusted to provide smooth operation and full travel.

The remainder of the installation is covered by the fitting instructions Nos. 11 - 16 inclusive given on Pages 4 & 5 of this bulletin.

Bulletin

MODEL: BENTLEY MARK VI

- 8 -

NOTE: The material supplied will include a radiator heated air duct and a demister motor. Although both these components may already exist on the car, credit will be allowed when these items are returned to the London Service Station.

<u>PART NO.</u>	<u>DESCRIPTION.</u>	<u>NO. REQD.</u>
R-4929	Air Intake Radiator Duct Assy.	1 Off.
R-4925	Demister Motor Assy. - Modified.	1 "
R-4396	(c) Throttle Mechanism Assy.	1 "
R-4433	(e) Locking Plate & Bolt Assy. - Heater Element Apertures	2 "
R-4432	(e) Blanking Plate - Heater Element Apertures.	2 "
R-4305	(e) Rubber Gasket - " " "	2 "
K-4304/2	(e) Nut - " " "	2 "
K-9005/2	(e) Spring Washer - " " "	2 "
RD-4575	(d) Breeches Piece.	1 "
RD-5938	(RH) Conduit Pipe - Air Intake Duct to Demister Motor.	1 "
RD-5939	(LH) " " " " " " " "	1 "
RD-6071	Hose - Conduit to Demister Motor.	2 "
RD-5941	Support Tube - Demister Motor.	1 "
RD-5942	Hose - Blower Motor to Support Tube	1 "
R-4385	Hose - Breeches Piece to Windscreen Ducts.	2 "
K-1910/2	(a) Setscrew - Breeches Piece & Support Tube to Dash.	4 "
R-4430	Grommet - Wires through Dash.	1 "
RD-4994	No.2 Jubilee Clip.	2 "
330/2868	No.3 " "	4 "
FB-4338	Hank Rivet Bush - Coil Fixing.	2 "
FB-4336	" " " - Ring Retaining-Speedo Cable Grommet.	4 "
KC-201/2	Setscrew - Blanking Existing R.H.Coil Hole in Dash.	1 "
K-9008/2	Spring Washer - For above.	1 "

All communications should be addressed to

BENTLEY MOTOR CO. LTD., 100, THE LANE, LONDON, E.C.4, ENGLAND.

Bulletin

MODEL: BENTLEY MARK VI

- 9 -

<u>PART NO.</u>	<u>DESCRIPTION.</u>	<u>NO. REQD.</u>
KC-203/Z	Setscrew - Blanking Existing L.H.Coil Hole in Dash.	1 Off.
K-4407/Z	Washer - for above.	1 "
K-4310/Z	Nut - for above.	1 "
RD-4226	Condensor - Coil.	1 "
R-1925/Z (c)	Setscrew - Support Tube, Throttle Barrel & Breeches Piece to Dash.	4 "
K-9006/Z	Spring Washer - Support Tube.	4 "
<u>NOTES:</u>	(c) Items NOT required if hinged flaps are fitted over outlet ducts at Windscreen.	
	(d) Items required if hinged flaps are fitted over outlet ducts at windscreen.	
	(e) Items NOT required after Chassis No.B-193-DZ.	

For identification of the above L.O.P. the Demister Motor Elbow is constructed from an aluminium tube as compared with the earlier scheme which used a cast elbow.

The following items have been superseded in the above L.O.P., but may still be required for replacement on cars which have been fitted with the earlier edition of this scheme.

R-4413	Air Intake Duct Assembly.	1 Off.
R-4360	Demister Blower.	1 "
RD-5077	Conduit Pipe.	1 "
R-4362	Support Tube.	1 "
R-4358	Hose - Air Intake Duct - Conduit Pipe.	1 "
R-4361	Hose-Support Tube to Motor.	1 "

ALL COMMUNICATIONS SHOULD BE ADDRESSED TO
BENTLEY MOTORS (UK) LTD. 22/23 LANE, CREWE, ENGLAND

Bulletin

MODEL: BENTLEY MARK VI

FOR INFORMATION.INSTRUCTIONS FOR FITTING MATRIX WITH DEEP FRONTAL AREAON EARLY MODEL BENTLEY MK. VI.

The following information is for the assistance of Retailers should it be decided to replace the original shallow type radiator matrix (Fig. 1) with the current deep type matrix (Fig. 2) in order to improve the cooling on early model Bentley Mark VI cars in service.



FIG. 1. SHALLOW MATRIX.
(ORIGINAL TYPE).

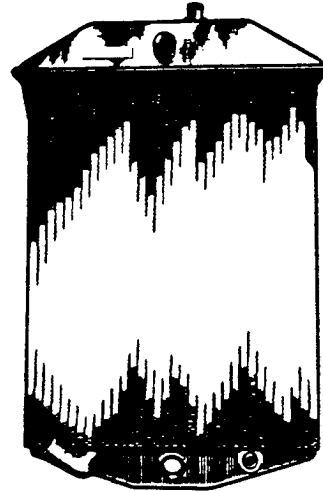

FIG. 2. DEEP MATRIX.
(CURRENT TYPE).

FITTING PROCEDURE.A. REMOVAL OF THE RADIATOR ASSEMBLY:

1. Remove the bonnet - withdraw the small bolt from the hinge-pin bracket on the dash.
2. Release the filler cap, and drain the cooling system by opening the tap on the pipe connecting the water pump with the bottom of the radiator.
3. Remove the forward right and left-hand front bumper retaining bolts, slacken off the remaining two bolts and allow the bumper assembly to swing downwards.
4. Open the front of the centre lamp, disconnect the wires and then pull these clear of the lamp bracket.
5. Remove the six bolts (three on each side) securing the front apron to the front wings. Remove the centre lamp.
6. Remove the right and left-hand front bumper fairings (if fitted).
7. Jack up the front of the car and remove the front road wheels.

Bulletin

MODEL : BENTLEY MARK VI

- 2 -

8. Disconnect the radiator from the valance plates as follows:-

- a) Remove the line of four setscrews along the leading edge of each front wing, and also the single setscrew (on either side) which is located approximately 2.00" to the rear of No. 2 screw (counting from the bottom) already removed. Remove the two bolts on either side which retain the horn brackets in position. (N.B. The horns should NOT be allowed to hang on their wires as they may become disconnected).
- b) Remove the bolts (one on either side) which secure the top of the yoke to the top of the valance plates.

9. Disconnect the top radiator hose connection.

10. Disconnect the bottom radiator hose connection. (N.B. The existing pipe connection should also be removed and discarded).

11. Remove the bottom centre screw securing the yoke to the front chassis cross-member, and with two operators pulling the wings slightly away from the radiator, lift and carefully remove the radiator assembly from the car.

B. DISMANTLING OF RADIATOR ASSEMBLY:

1. Remove the outer shell from the radiator (six screws and nuts at the top and two setscrews along the bottom edge).
2. Bend the locking tabs up and remove the wedges from the top of the yoke side members.
3. Remove the two diagonal stiffeners across the rear of the yoke, and then slide the matrix out.

C. MODIFICATION OF THE EXISTING YOKE:

NOTE: This is necessary in view of the increased length of the new type matrix. Figs. 3 & 4 illustrate the yoke before and after modifying and are included as a means of assistance to operators when carrying out the following instructions.

1. Using a cold chisel, cut the spotwelding at each end of the matrix cradle (1, Fig. 3) and remove the cradle. Clean up the two supporting straps with a file, and then bend these downwards parallel with the sides of the yoke (as shown in 1, Fig. 4).
2. Cut away the spotwelding between the baffle plate (2, Fig. 3) and the yoke frame and remove the plate. Clean up the frame with a file.
3. Cut off a section of the original cradle to correspond with the flat at the bottom of the yoke frame and position this as shown (2, Fig. 4). Slide the new matrix into the yoke so that it rests correctly on the bottom, mark off the relative position of the cradle, and then sweat the new cradle strip to the bottom of the yoke. Replace the new matrix in the yoke and lock in position by means of the original wedges. Refit the two diagonal stiffeners.

ALL COMMUNICATIONS SHOULD BE ADDRESSED TO

BENTLEY MOTORS (1931) LTD., PYM'S LANE, CREWE, ENGLAND

SECTION

N.

PRINTED IN ENGLAND

SB/GF. 1/JSK. 23.10.50.

Bulletin

MODEL: BENTLEY MARK VI

- 3 -

4. Fit the new drain tap (RE-3850) into the bottom tank on the right-hand side of the matrix. The tap handle should point to the right and be parallel with the ground (it may be necessary to use both aluminium washers (E-27488) in order to obtain this condition). Fit the new drain pipe (RE-3845) to rear of drain tap, ensuring that this points downwards.

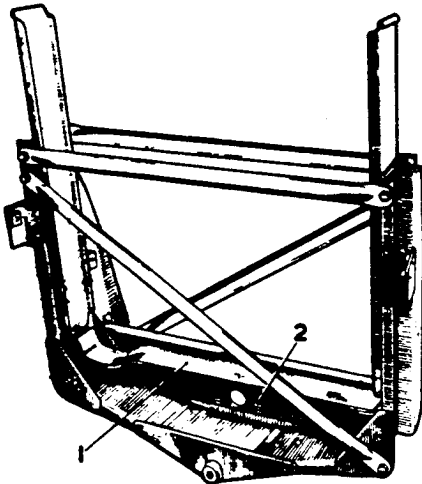

FIG. 3. YOKE UNMODIFIED.

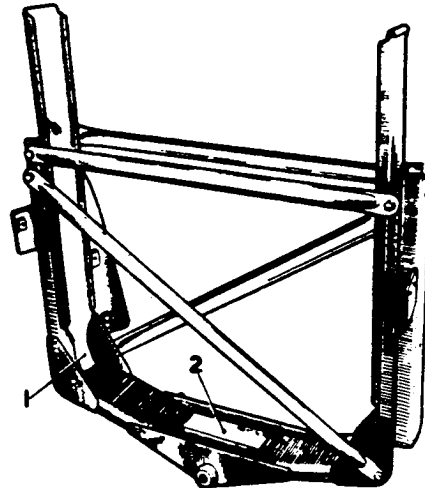

FIG. 4. YOKE MODIFIED.

5. Refit the outer shell to radiator and then re-assemble the complete unit on the car. Line up the new water pump bottom pipe connection (RE-4773) with the bottom tank connection pipe on the left-hand side of the matrix and tighten up the rubber hose connections.

Complete the remainder of the re-assembly of the parts either removed or disconnected. Refill the cooling system.

MATERIAL REQUIRED.

<u>PART NUMBER</u>	<u>DESCRIPTION.</u>	<u>NO. REQ.</u>
RE-9217	Radiator Matrix - Deep Type.	1 off.
RE-4773	Pipe - Bottom Water Connection.	1 off.
RE-3845	Pipe - Drain Tap.	1 off.
RE-3850	Drain Tap.	1 off.
E-27488	Washer - Drain Tap.	2 off.

ALL COMMUNICATIONS SHOULD BE ADDRESSED TO
BENTLEY MOTORS (INDIA) LTD., 21/23 LANE, CREWE, ENGLAND

COOLING - BENTLEY MARK VI.

Some complaints have been received of boiling on recent cars during Alpine climbing in hot weather. It would appear that the margin of safety is not very high on certain cars, and tests have accordingly been carried out to establish the cause and cure.

The following notes may be useful in dealing with complaints:-

1. Tests have shown that the angle of the shutters, by diverting the air to right and left of the centre line of the radiator, leaves a strip about 8" wide down the centre of the radiator which is not cooled by the incoming air. The greatest improvement can be made by altering the shutter angle from 43° , the present setting, to 37° .

This can be done by removing a rivet from each end of the shutters, swinging the shutter on the remaining rivet, and soldering in the new position. The best results are obtained with the widest gap possible consistent with reasonable appearance.

2. The mixture strength on $4\frac{1}{2}$ litre cars may be too weak. The carburettor needles originally fitted were SN. A useful improvement both in power and coolness of running can be achieved by fitting SP needles. These needles have now been standardised.
3. Some radiators may be partially choked with insects, butterflies or paint. A useful improvement can sometimes be made by cleaning the radiator.
4. Where silting up is suspected, the system should be thoroughly flushed out, and an alteration to the dynamo circuit made to neutralize electrolytic action. This will be the subject of a further Bulletin, meantime apply to Hythe Road for details in complaint cases.
5. The fan speed was reduced at Chassis No.B-213-GT in order to reduce fan noise. This has slightly reduced the cooling efficiency but not sufficiently to cause overheating unless the safety margin is low for other reasons.

Bulletin

MODEL BENTLEY MARK VI

THIS BULLETIN CANCELS:

BB-142	dated	4. 3.52	BB-145	dated	25. 3.52
BB-142	"	22. 7.53	BB-110	"	9.10.50
BB-142a	"	9. 5.52	BB-112	"	7.12.50
BB-142a	"	14.10.53	BB-112a	"	21.6.51
BB-144	"	10. 3.52			

OVERHEATING DUE TO CHOKED RADIATORSGENERAL:

Instances of overheating have been the subject of investigation for some time and the Bulletins mentioned above were issued to assist all concerned.

Further investigation and research into the causes now necessitate the issue of modified information, and it has therefore been decided, for the sake of simplicity, to cancel all previous Bulletins and include in this one, all the available information.

The majority of overheating complaints are due to choking of the upper portion of the radiator waterways by silt formed of corrosion products.

Most proprietary anti-freezes contain an inhibitor to retard corrosion, but if they are left in the system indefinitely, acids are formed and the cast iron cylinder block is attacked. In addition, since the components of the cooling system are of dissimilar metals, there is corrosion by electrolytic action. In effect, even inhibited anti-freeze not only loses its capacity to retard corrosion, but ultimately assists in the formation of silt.

It has been found that additional protection can be obtained from inclusion of another chemical in proprietary anti-freezes. This has now been added to the ethylene glycol used at the factory and at the Service Dept. Arrangements have also been made to include it in the proprietary anti-freeze which we recommend.

In normal circumstances, silt is circulated round the system and will not block the radiator unless the concentration is very high, but in the presence of a large difference in electrical potential between the engine and radiator, the silt, which has high iron content, adheres to the radiator as in electro-plating. The existence of such an electrical condition was discovered during general investigation into the overheating problem and was largely eliminated by special bonding of the electrical system.

As a further safeguard against corrosion, the interior of the engine block is now coated with an aluminium pigmented stove enamelling varnish in order to reduce the area of iron in contact with the coolant to a minimum, but this cannot be applied retrospectively.

In spite of all precautions, it remains undesirable to keep anti-freeze in the system too long, and we recommend that it should be changed once a year.

- 2 -

SILT FORMATION AND PREVENTION

The silt consists of about 80% iron oxide, resulting from corrosive attack of the coolant on the cast iron of the engine block. A small quantity of iron forms a comparatively large volume of silt, and although the amount of metal removed is insignificant, the results from a cooling view-point may be serious.

The cooling system is, of necessity, a multi-metal one, and any coolant will attack the various metals after a considerable period of service. Tap water will corrode iron; the alcohol and ethylene glycol anti-freezes, and the majority of corrosion inhibitors and radiator cleansing chemicals, will eventually attack the metals of the system. Once this action commences, it is difficult to stop, a normal flush out and coolant change being insufficient unless the corrosion products are entirely removed or chemically neutralised.

Apparently unrelated variations in design or in service conditions may effect the rate of silt formation between one model and the next, or even between similar cars. The type of coolant, its chemical composition, its velocity at certain points of the system and at different metal/coolant faces, its degree of aeration, oxidation and length of service, the running temperatures and gradients, individually or together with the various combinations of metals in the system, may greatly accelerate or retard the action.

In order to reduce the effect on iron triethanolamine phosphate inhibitor was added to the ethylene glycol used at the factory, and to the recommended proprietary anti-freeze. This forms a thin protective film on the iron, preventing further attack. Unfortunately high coolant velocities destroy this film by erosion, when the inhibitor again combines to reform the film, while the matter removed by this cycle appears in suspension the cooling system as ferrous-ic phosphates or hydroxides. The copper in the system combines with the inhibitor, producing cuprous-ic salts which act as a catalyst, accelerating the corrosion of iron should the same coolant be retained for long periods.

A further inhibitor, sodium mercaptobenzothiazole has now been added, which protects the copper in a similar manner to the iron corrosion inhibitor, thus preventing the formation of the catalyst and results in long-term protection of the iron.

The mercaptobenzothiazole component of the inhibitor is consumed both by oxidation, and by its utilisation in creating the protective film on copper. As with the phosphate film on iron, erosion occurs and the inhibitor is slowly consumed in re-forming the film.

Should this inhibitor be used in systems which were previously unprotected, the copper corrosion products present will result in its rapid consumption and may cause complete exhaustion within a few hours, but if the precautions outlined under "Annual Routine Servicing" are carried out, the benefit of the triethanolamine phosphate and sodium mercaptobenzothiazole inhibitors will be obtained, giving full protection to the cooling system for twelve months service.

ALL COMMUNICATIONS SHOULD BE ADDRESSED TO

BENTLEY MOTORS (UK) LTD. SERVICE DEPARTMENT, THE ROAD, WINDYBACH, WILTSHIRE

Bulletin

MODEL BENTLEY MARK VI

- 3 -

A ready means of identifying anti-freeze containing the additional inhibitor has been provided by the addition of a small quantity of the sodium salt of fluorescein which imparts a distinct fluorescent effect to Bluecol and to the ethylene glycol used at the factory. The former remains blue, but the latter is discoloured a yellowish-green.

WORKSHOP ACTION:

The action to be taken in Workshops can be divided into the following categories:-

1. Routine annual changing of anti-freeze.
2. Modification of the electrical bonding.
3. Protective action while decarbonizing or whenever the system is to remain dry.
4. Flow testing the radiator.

ANNUAL ROUTINE SERVICING:

Drain the system and flush out as follows:-

1. Remove the top and bottom radiator hoses and reverse flush the radiator with mains pressure for $\frac{1}{2}$ hour.
2. Remove the cylinder block drain tap and thermostat or thermostat housing and flush from both ends for about $\frac{1}{4}$ hour each.
3. Refill the system.
- 3a. Smith's "Bluecol" anti-freeze and the Ethylene Glycol used at the factory now both contain the new inhibitor, but before using either in a car which has been filled with the earlier anti-freeze, the following action is necessary to conserve the new inhibitor which will otherwise be consumed within a few hours.
 - a) Start the engine and run for a few minutes.
 - b) Remove cylinder drain cock and insert a hose into the radiator, run the engine, occasionally opening the throttle slightly until the water runs clear; this usually takes about 20 minutes.
 - c) Replace the drain cock, add $\frac{1}{2}$ pint of Stergene to the full system and run for 5 minutes at normal engine temperature.

Bulletin

MODEL : BENTLEY MARK VI

- 4 -

- d) Repeat (b) and run until cool, then switch off and leave until engine is cold. Start up and run until the water ceases frothing.
- e) Drain and refill with anti-freeze.

This operation need only be done once on any car, provided that the owner continues to use the recommended anti-freeze.

NOTE: A distinct fluorescent effect can be observed in the new type proprietary anti-freeze; the ethylene glycol equivalent is yellowish-green.

MODIFICATION OF ELECTRICAL BONDING AND INSULATED DYNAMO:**Basic Requirements:**

The retardation of silting by electrolytic methods has been achieved by insulating the dynamo from the engine, bonding dynamo to radiator and utilising the current to reverse the normal polarity of the potential differences existing between radiator and engine.

The radiator must be at least 2M.V positive to engine when the headlights are on and the engine running with the ammeter reading zero. With no electrical load and the ammeter reading 10 amps. charge, the radiator should not be greatly in excess of 25 M.V positive to engine. These readings may be checked by millivolt meter or Avometer, if available. Avometer Model 7 gives a direct millivolt reading when set to the 2 m.a. range D.C.

Various methods of bonding have been used, not all of which have produced the desired polarity. Those which are doubtful require further modification on a Category 2 basis. For these cases, a new type of bonding has been devised which automatically gives the correct conditions without necessitating the use of an instrument for checking.

BONDING:

The existing and new bonding systems are as follows:-

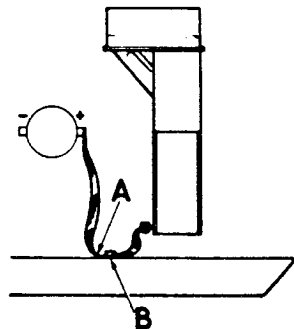

P.1. 1st Production Scheme.

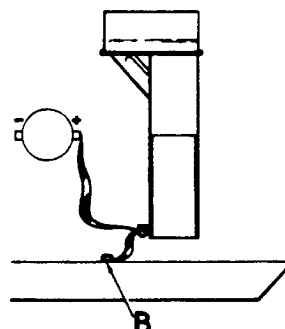

P.2. 2nd Production Scheme.

ALL COMMUNICATIONS SHOULD BE ADDRESSED TO
BENTLEY MOTORS (1951) LTD. SERVICE STATION, HYTHE ROAD, WILLESDEN, LONDON, N.W.10

SB/TJ. 6/JSB...12.5.54.

SECTION N.

Bulletin

MODEL BENTLEY MARK VI

- 5 -

Production schemes may be recognised by the provision of a separate bolt (B) for the bonding on the R.H. frame member.

Scheme P.1. to be modified to Scheme P.2. by cutting off the bonding braid at A as close to the bolt as possible. Fit a new strip as in P.2. (Category 2 Action).

MATERIAL REQUIRED:

Bonding Strip, Dynamo to Radiator. RD-7568 1 Off.

TIME ALLOWANCE: 1 Hour.

CHASSIS NUMBERS AFFECTED:Bentley Mk.VI.

B-330-MD; B-334-MD to B-340-MD inclusive.
B-390-MD to B-400-MD inclusive; B-15-MB.
B-131-MB to B-137-MB inclusive; and
B-233-MB to B-208-TN inclusive (or to B-130-TN on Coachbuilt Bodies).

Bentley Continental: BC-1A to BC-23C inclusive.

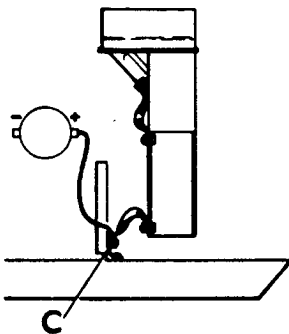

S.1. 1st Service Scheme.

1st Service Scheme (S1) to be modified to 3rd Service Scheme S3. (Category 2 Action).

Material:- Bonding assembly R-5007.
Clip F-59140 1 off.

Time Allowance:- 1 Hour.

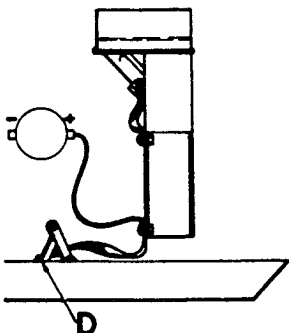

S.2. 2nd Service Scheme.

2nd Service Scheme (S2) to be modified to 3rd Service Scheme (S3) only where values are checked and found to be incorrect or on overheating complaints.

Material:- Bonding assembly R-5007.
Clip F-59140 1 off.

Time Allowance:- 1 Hour.

ALL COMMUNICATIONS SHOULD BE ADDRESSED TO:

BENTLEY MOTORS (HVS) LTD. SERVICE STATION, MYTHE ROAD, WILLESDEN, LONDON, N.W.2

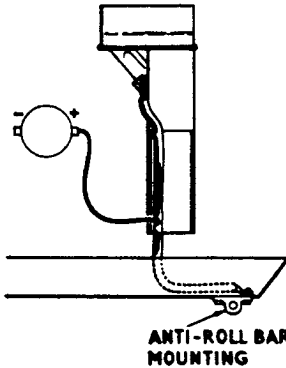

3rd Service Scheme (S3). The braid is run down the channel formed by the outer side member of the radiator yoke, and the whole bonding positioned to avoid the possibility of contact with sharp edges. The lower end with the 5/16" eye is fitted to the front bolt of the anti-roll bar and the upper end to the radiator header tank strut as shown in the diagram; both contact surfaces must be clean.

It is essential to fit bonding eye direct to frame - not to bracket.

S.3. 3rd Service Scheme.

DYNAMO INSULATION:

Insulation of the dynamo from the cylinder block is associated with the bonding and should be done when the bonding is originally fitted.

There are two methods of insulating the dynamos:-

1. On production and replacement dynamos, the positive brush is insulated and a terminal provided opposite the negative terminal (Fig. 1).
2. On existing dynamos, the bracket is insulated from the dynamo by means of special fibre bushes and washers, the bonding cable being attached to the rear mounting bolt as in Figs. 2 and 3.

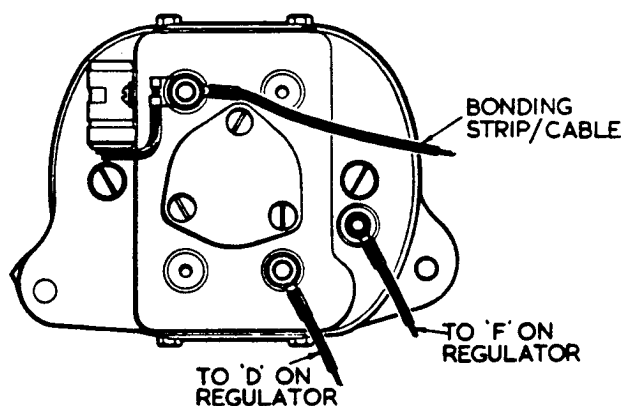

Fig. 1.

Bulletin

MODEL: BENTLEY MARK VI

- 7 -

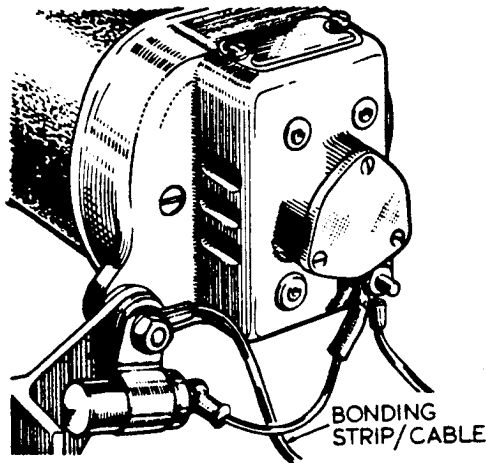

Fig. 2.

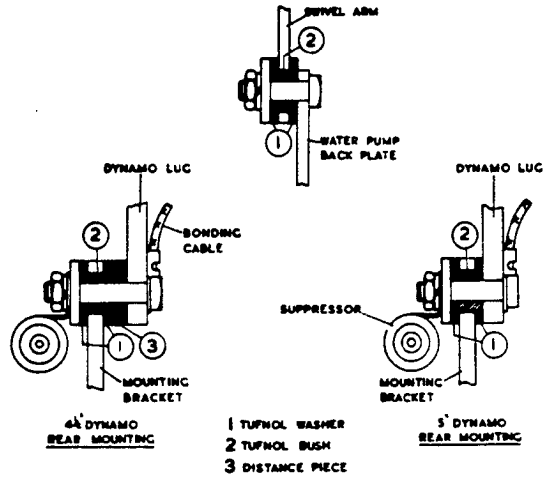

Fig. 3.

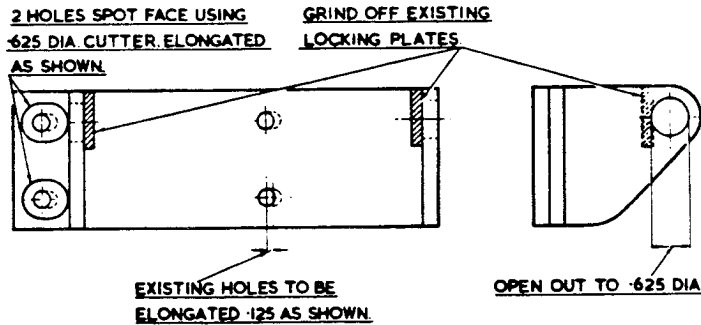

Fig. 4.

Fig. 3 shows the method of mounting the dynamo and insulators, but it should be noted that the distance piece (3) is only used on the C-45-FV dynamo. The modifications required on the C-45-FV bracket itself are shown in Fig. 4; these brackets are not supplied. The RA-5 bracket is available from the Service Department.

Bulletin

MODEL: BENTLEY MARK VI

- 8 -

MATERIAL REQUIRED:-

(For either type of Dynamo):

Bush, Tufnol	R-4677	3 off
Washer, Tufnol	R-4673	6 off
Bonding Assembly	R-5007	1 off
Clip, Cable	F-59140	2 off
Washer, Dynamo to Bracket	R-4803	3 off
Bolt, Swivel Arm to Crankcase	K-308	1 off
Bolt, Bonding to Matrix	KA-202	1 off
Nut, Bonding to Matrix	K-4008	1 off
Washer, Bonding to Matrix	K-9008	1 off
Bracket, Dynamo Mounting (RA-5 Dynamo only).	R-4574	1 off
Swivel Arm (RA-5 Dynamo only).	R-4676	1 off
Bolt, Dynamo to Bracket (RA-5 Dynamo only).	K-312	2 off
Swivel Arm (C-45-PV Dynamo only).	R-4733	1 off
Bolt, Dynamo to Bracket (C-45-PV Dynamo only).	K-312	1 off
Bolt, Dynamo to Bracket (C-45-PV Dynamo only).	K-314	1 off
Distance Piece (C-45-PV Dynamo only).	R-4734	1 off

TIME ALLOWANCE: 4 Hours

NOTE: The C-45-PV ($4\frac{1}{2}$ ") Dynamo is fitted on Chassis Nos. B-2-AK to B-424-CF inclusive. The RA-5 dynamo is fitted on Chassis No. B-426-CF onwards.

Price of material is available on request at the London Service Station.

Material ordered for stock will be invoiced, but may be charged back to the Company if used under guarantee.

PROTECTION OF EMPTY COOLANT SYSTEMS:

It is important that the cooling system should not be allowed to dry without first removing the accumulated silt, otherwise this may be very difficult afterwards and will lead to overheating immediately after decarbonizing and similar work.

Whenever the cylinder head is removed, the cylinder block should be cleaned out by removing the drain cock and connecting a pressure wash hose to a $\frac{1}{4}$ " tube, the end of which is blanked off and a delivery aperture cut in the wall as close to the end as possible. The tube is then inserted to the bottom of each waterway and the jet directed along each channel in turn. The results should be checked by dipstick methods to ensure that all silt has been removed. The cylinder block should then be refilled up to the diffuser tube level and the radiator refilled and plugged.

All communications should be addressed to

BENTLEY MOTORS (UK) LTD. SERVICE STATION, HYTHE ROAD, WILLESDEN, LONDON N.W.11

SB/TJ 6/JSB...12.5.54

SECTION N

Bulletin

MODEL: BENTLEY MARK VI

- 9 -

Similar precautions should also be taken with the cylinder block when a new radiator is fitted. In this case, if the head is not removed, it should be flushed as described in (2) under Annual Routine Servicing.

RADIATOR FLOW TESTING:

The radiator may be checked by means of a water flow test. A container with a 1" bore pipe let into the bottom should be hung above the radiator and connected to the header tank intake pipe, the radiator lower connection being allowed to run to waste. The tank should be suspended so that the centre is 3ft above the radiator intake pipe, when the time taken for the tank to empty will give an approximation of the condition of the matrix. The figures given below do not include the time required for the radiator to empty after the flow from the tank has ceased. The water level in the tank may be observed if the top is cut open; a mirror attached at a suitable angle would permit observation from ground level.

<u>Container:</u>	<u>Mk.VI Rad</u>	<u>Mk.VII Rad</u>
5 Gall. (Oil Drum)	14 secs.	22 secs.
10 " (Tank)	28 "	44 "
18 " (Petrol Tank)	50 "	80 "

These flow times are for a radiator in new condition.

NOTE: The Mk.VII radiator which was fitted on Chassis No. B-270-DA and onwards, incorporates a drain tap and a starting handle tunnel in the bottom tank, neither of which is featured on the earlier type.

Should the flow time exceed those quoted by over 25%, it is probable that the radiator is the cause of overheating, and should be replaced. It is not now considered advisable to attempt any chemical de-silting owing to the high percentage of subsequent leakage complaints.

When fitting a replacement radiator, it is essential to flush out the engine thoroughly. The thermometer and thermostat should be carefully checked, as these may be damaged by severe overheating.

A radiator with a flow figure of less than 25% above the nominal should be given a Cooling System Service as a preventative measure, but it is not likely to be the cause of overheating in this condition.

Category 3A. Chassis No. B-270-DA & Onwards:

CORRUGATED HOSE CONNECTION - RADIATOR TO WATER PUMP.

A flexible corrugated rubber hose is now being fitted between the coolant pump and the bottom outlet pipe of the radiator. This is intended to reduce the strain on the bottom connection, which arises from relative movement between the radiator and engine.

The original hose connections were of stiffer rubber, and fractures have occurred at the junction of the pipe with the radiator bottom tank.

The new rubber hose (Part No. RE-18218) should be fitted to cars with deep type matrices whenever a radiator is changed, or when the engine is decarbonised.

If the radiator is changed under guarantee, the hose should be supplied free of charge; in other cases it is a chargeable item.

It is recommended that appropriate quantities should be ordered and held in stock.

MODIFICATIONFor Category 2 Action:The Bentley Continental Heater Return Pipe.

It has been found in service that the heater return pipe on the Bentley Continental Sports Saloon is subject to fracture at the junction of the return pipe from the underwing demister unit, due to strain. The junction is shown in Fig.1.

From Chassis Number BC-29-C and onwards a new pipe having a strong saddled junction is being fitted on production. The return pipe from the demister unit is joined with a short length of rubber hose and two clips in place of the earlier screwed union. In this way the strain at the junction is relieved. (Fig. 2).

The new heater return pipe is to be fitted as a retrospective modification and Retailers are asked to modify any cars in their area when next they are serviced.

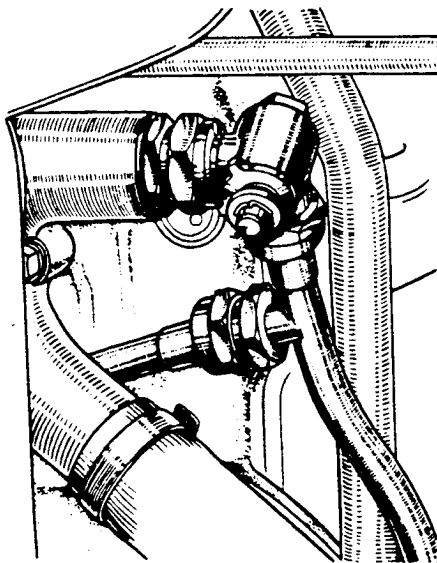

FIG. 1 THE EARLY HEATER
RETURN PIPE.

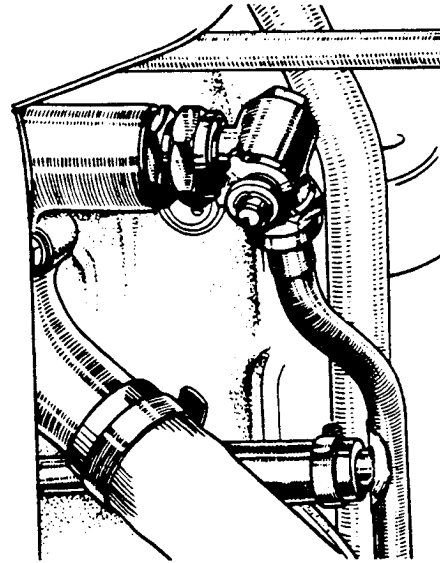

FIG. 2 THE NEW HEATER
RETURN PIPE.

MATERIAL:

RE.18690	Heater return pipe	1 off
RE.9418	Clip, connecting hose	2 off
R.4093	Rubber hose	1 off

These parts will be supplied upon application to the London Service Station.

Bulletin

MODEL: BENTLEY MARK VI

- 2 -

PROCEDURE:

1. Drain the cooling system.
2. Disconnect the demister unit return pipe at the rubber hose connection. This pipe is the lower of the two pipes leading into the wing on the right hand side of the engine.
3. Disconnect the heater return pipe at the junction below the tap on the water pump (A Fig. 1).
4. Remove the nut retaining the heater return pipe clip on the timing case retaining bolt and disconnect the bottom of the pipe at its rubber hose connection.
5. Remove the pipes from the engine and disconnect the demister return pipe at its screwed union. With a hacksaw, cut the demister return pipe at its bend approximately $2\frac{1}{2}$ " from the union end. Swage over the cut end to form a lip for the rubber hose and fit the hose and clip. Fit the hose to the heater return pipe but do not tighten the clip.
6. Refit the pipes to the engine and tighten the hose clip when the pipes are correctly positioned.
7. Refill the cooling system.

CHARGES:

Charges should be submitted on a Guarantee Form in the usual way. A time of 2 hours is allowed.

Bulletin

MODEL BENTLEY MARK VI

FOR INFORMATIONTHREE POSITIONHEATER AND DEMISTER SWITCHES.

Cases have occurred of heater and demister motors failing to start at low temperatures with the switches in the slow speed position. This Bulletin sets out details of a method of reducing the internal resistance of the switch at the slow speed position from 7 ohms to 5 ohms to ensure that the motor will start at all temperatures.

It is pointed out, however, that a new heater may not operate satisfactorily at slow speed until after a reasonable period of running in. A modification to the switch to meet a customer's complaint should not be carried out until after running in is completed.

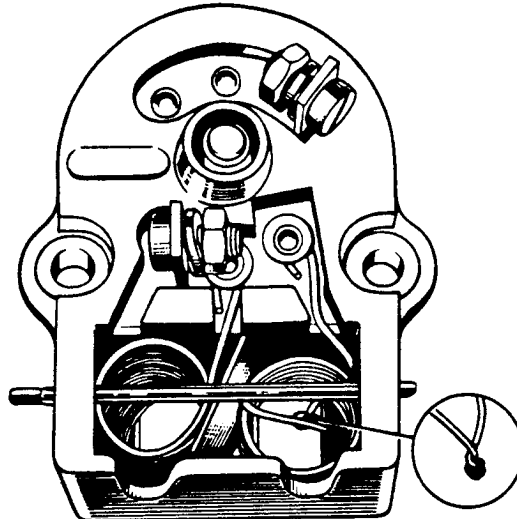

THE MODIFIED SWITCH SHOWING
THE 'BLOB' WELD.

TO MODIFY THE SWITCH.

- (i) Remove the wooden facia panel and remove the switch from the instrument board.
- (ii) Remove the pin retaining the two resistance coils after clinching one end in a vice. Pull out the mica separator.
- (iii) Cut off the wire from one terminal at the first coil so that approximately 1" (25 mm) is left attached to the terminal. Bend this short length upwards.
- (iv) Ease up the free set of coils with a screwdriver and cut off 13 complete coils.

Bulletin

MODEL BENTLEY MARK VI

- 2 -

- (v) Rejoin the wire by twisting the free ends together. Weld the twist together to leave a blob at the end as shown in the illustration. A carbon arc should be used operating at 8 to 12 volts and a flux mixture of calcium fluoride and borax is recommended.
- (vi) Bend the joined wires so that they lie inside but clear of the coil. Replace the mica separator and retaining pin. The resistance measured across the terminals should now be between $4\frac{1}{2}$ and 5 ohms.
- (vii) Refit the switch and fascia board.

Where facilities for welding are not available the modified switch may be obtained from the London Service Station under Part No. R.5321. The replaced switch should be returned to the London Service Station.

Bulletin

MODEL: BENTLEY MARK VI

FOR INFORMATION.HEATER SPARE PARTS.

Retailers are advised that the following spare parts are now available for standard underseat and underdash heaters:

1. RD.3283 Shallow Matrix Underseat Heater

Fitted to: Bentley Mark VI, Series A,B,C and D up to Chassis No:B-235-DZ

CD.317	Motor CHS 352
CD.318	Mounting Rubber - Motor (6 Off Required)
RE.10659	Matrix
R.4342	Fan

2. RD.6924 Deep Matrix Underseat Heater

Fitted to: Bentley Mark VI and 'R' Type from Chassis No:B-237-DZ onwards

CD.316	Motor CHS 364/4
CD.318	Mounting Rubber - Motor (6 Off Required)
RD.7853	Matrix
RD.6923	Fan

3. RD.7039 Underdash Heater

Fitted to: Bentley Continental

R.4784, R.4783 Underdash Heaters

Fitted to: Bentley Mark VI and 'R' Type as additional heaters when required.

CD.316	Motor CHS 364/4
CD.318	Mounting Rubber - Motor (6 Off Required)
R.4789	Fan
R.4785	Matrix (Bentley Mark VI and 'R' Type only)
RE.10659	Matrix (Bentley Continental only)

These parts may be fitted under the terms of the Manufacturer's Guarantee if the heater is within the Guarantee Period.

New Mounting Rubbers are required whenever a new motor is fitted.



MODEL BENTLEY MARK VI

RADIATOR TOP HOSE.

A new rubber radiator top hose is now available for replacement purposes. The hose is corrugated for $2\frac{1}{4}$ " at the radiator end and provides a more flexible connection between the radiator and thermostat housing. It replaces the two short rubber hoses and metal pipe fitted on production models.

The new hose should be fitted whenever replacement is necessary and should be retained with two of the four jubilee clips removed from the old assembly.

Parts Required.

RE.18853 Hose - top water connection 1 Off.

Bulletin

MODEL BENTLEY MARK VI

FOR INFORMATION.ANTI-FREEZE MIXTURES.

Only an anti-freeze mixture to specification DTD.779 should be used, and the following is a list of those officially recommended:-

Bluecol	-	Messrs Smiths (M.A.) Ltd.
Snowflake	-	Messrs Snell Oil Co.Ltd.
Polar Anti-freeze	-	Messrs Germ Lubricants Ltd.
Greenglow	-	Messrs Calder Oils Ltd.
Lautol	-	Messrs James Light & Son Ltd
Synool (without suffix)	-	Messrs Synthetic Ltd.
Esso Anti-freeze	-	Messrs Esso Petroleum Co.Ltd.

FOR INFORMATIONREPLENISHMENT OF NaMBT INHIBITOR IN
NEW OR CLEANSED COOLANT SYSTEMS

The recommended anti-freezes, which are to specification DTD 779, contain two corrosion inhibitors. One of these, NaMBT (Sodium mercapto-benzothiazole), may be consumed rapidly on initial filling, even in a new cooling system, with consequent loss of protection against corrosion.

On cars delivered recently a small sachet has been provided, to replenish this inhibitor after 1500 miles. It is now proposed to extend this to all post-war cars when the radiator or engine is changed or when the system has been cleaned by flushing out.

This single replenishment of the inhibitor is normally sufficient to ensure that the coolant will fulfil its functions for the whole of its 12 months useful life.

It is essential that the contents of the NaMBT sachet are not added to any coolant other than one containing anti-freeze to Specification DTD 779.

Sachets of Inhibitor (Part No. Y. 9111) are available from Rolls-Royce, London, N. W. 10.